

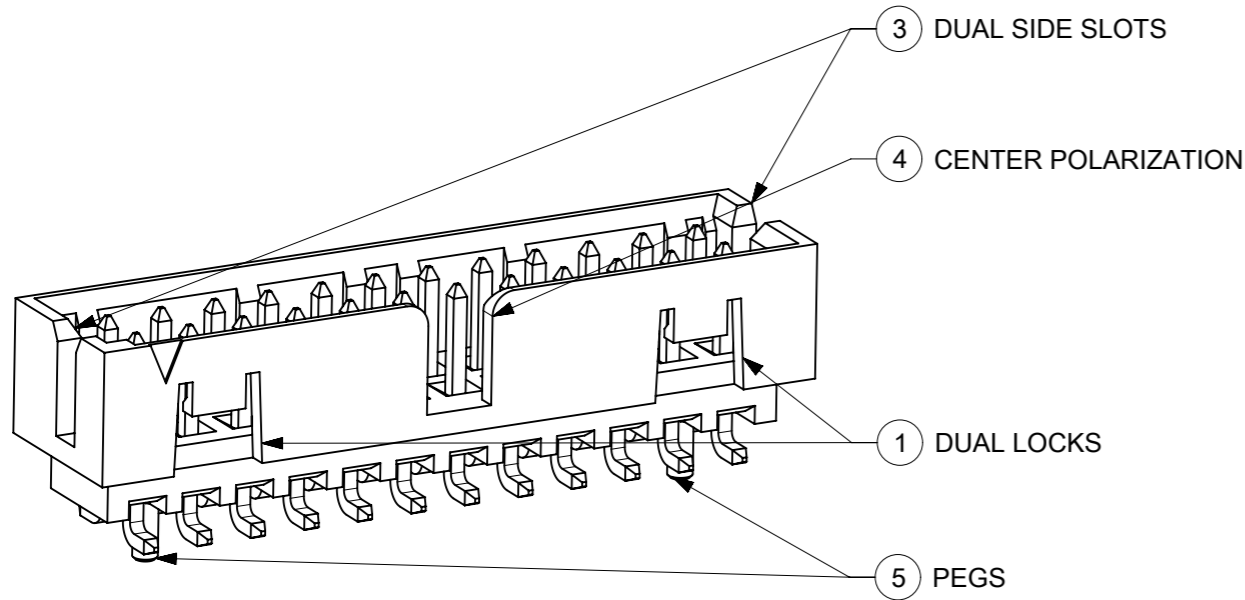

THE DATASHEET OF
87832-1414

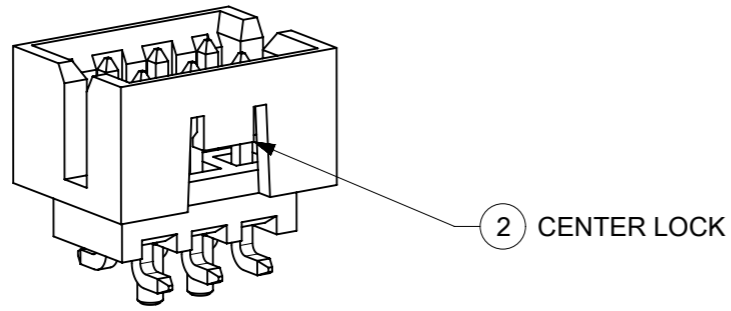

FEATURES SELECTION GUIDE



CIRCUIT SIZE	FEATURES					SHEET NO
	FRICTION LOCKS		DUAL SIDE SLOTS	CENTER POLARIZATION	PEGS	
	① DUAL	② CENTER				
4	N.A	N.A	YES	N.A	N.A	2 - 3
	N.A	YES	YES	N.A	N.A	
6	N.A	N.A	YES	N.A	N.A	4 - 5
	N.A	N.A	YES	N.A	YES	
	N.A	N.A	YES	YES	N.A	
	N.A	YES	YES	N.A	N.A	
	N.A	YES	YES	N.A	YES	
8 TO 12	N.A	N.A	YES	YES	YES	6 - 7
	N.A	N.A	YES	YES	N.A	
	N.A	YES	YES	N.A	N.A	
14 TO 50	YES	N.A	YES	YES	N.A	8 - 11
	YES	N.A	YES	YES	YES	

THIS DRAWING CONTAINS INFORMATION THAT IS PROPRIETARY TO MOLEX ELECTRONIC TECHNOLOGIES, LLC AND SHOULD NOT BE USED WITHOUT WRITTEN PERMISSION

EC NO: 621140 DRWN: NMANE02 CHK'D: NMANE02 APPR: MRAMAKRISHNA 2019/07/23 2019/07/23 2019/07/23	GENERAL TOLERANCES (UNLESS SPECIFIED)		DIMENSION UNITS		SCALE					
			MM	INCH	MM	NTS				
	4 PLACES ±	±	DRWN BY		DATE		MILLIGRID 2MM PITCH, SMT VERTICAL SHROUDED HEADER			
	3 PLACES ±	±	GMENARLY		2015/05/22					
	2 PLACES ± 0.2	±	CHK'D BY		DATE					
	1 PLACES ±	±	CGOH		2015/09/21		PRODUCT CUSTOMER DRAWING			
0 PLACES ±	±	APPR BY		DATE						
ANGULAR TOL = 3.0		KHLIM		2015/09/22		SERIES	MATERIAL NUMBER	CUSTOMER		
DRAFT WHERE APPLICABLE MUST REMAIN WITHIN DIMENSIONS		DRAWING SIZE		THIRD ANGLE PROJECTION		87832	SEE TABLE	GENERAL MARKET		
A12	REV	A3				DOCUMENT NUMBER		DOC TYPE	DOC PART	SHEET NUMBER
						SD-87832-0001		PSD	001	1 OF 13

RELEASE STATUS	P1	RELEASE DATE	2019/07/23	11:08:01
----------------	----	--------------	------------	----------

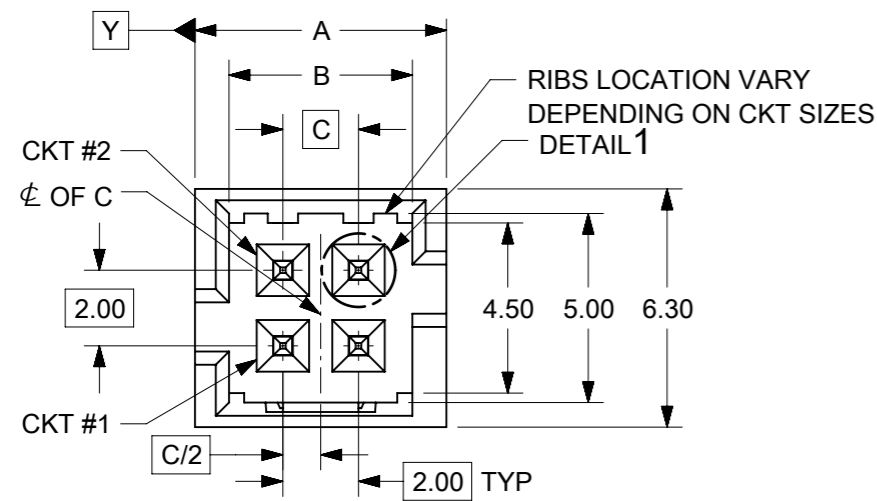

4 CIRCUITS

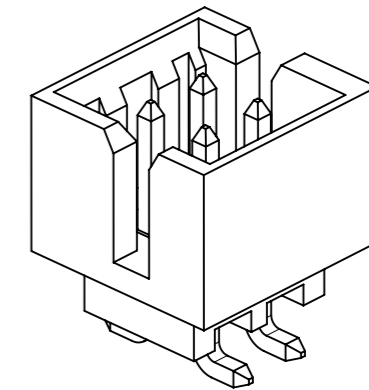
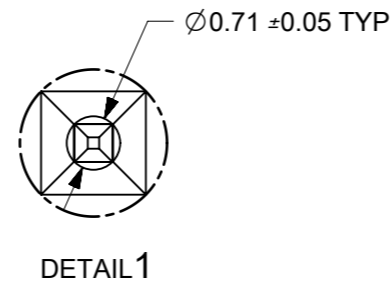

ISO VIEW OF HEADER WITH ONLY DUAL SLOTS

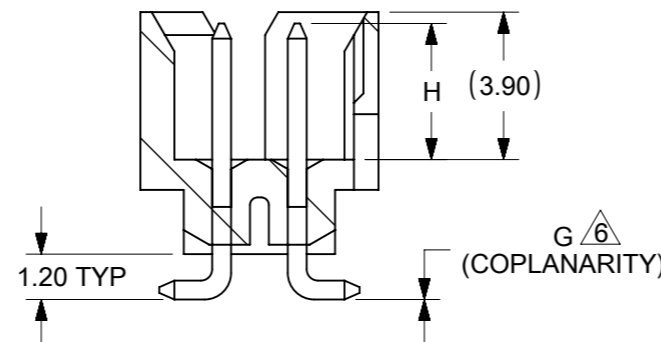
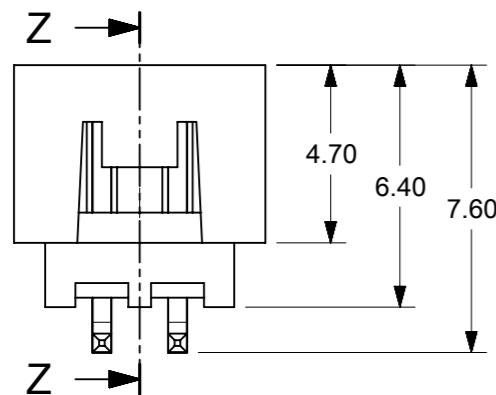

SECTION Z-Z

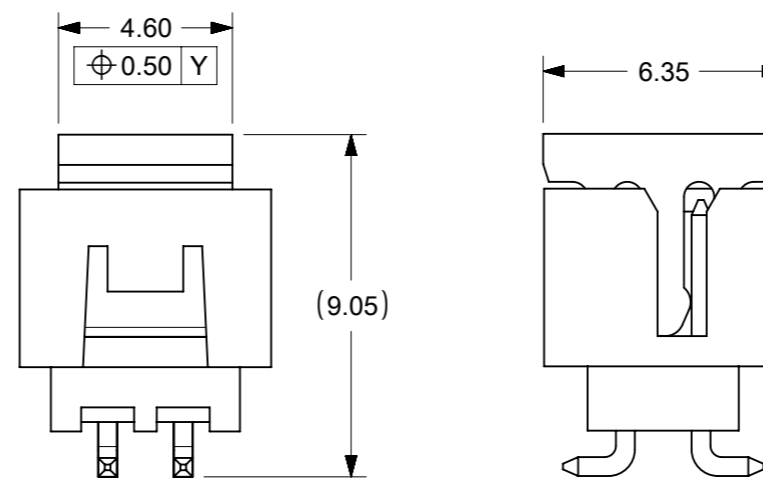
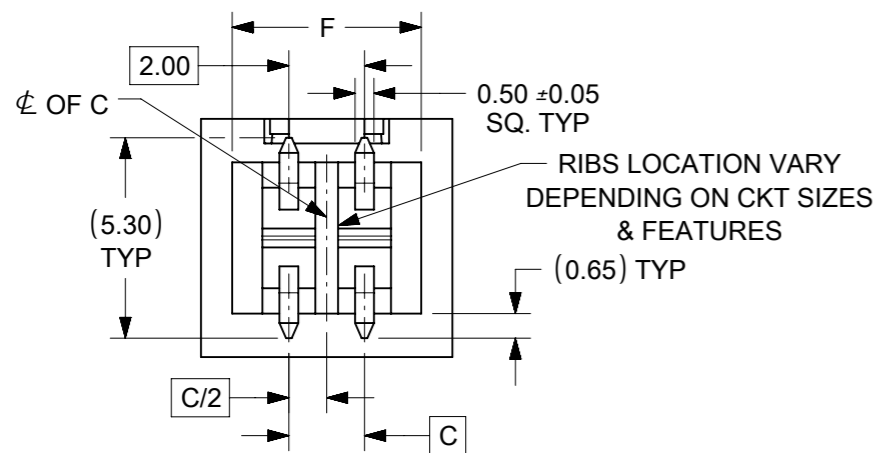

VIEW FOR HEADER WITH CAP

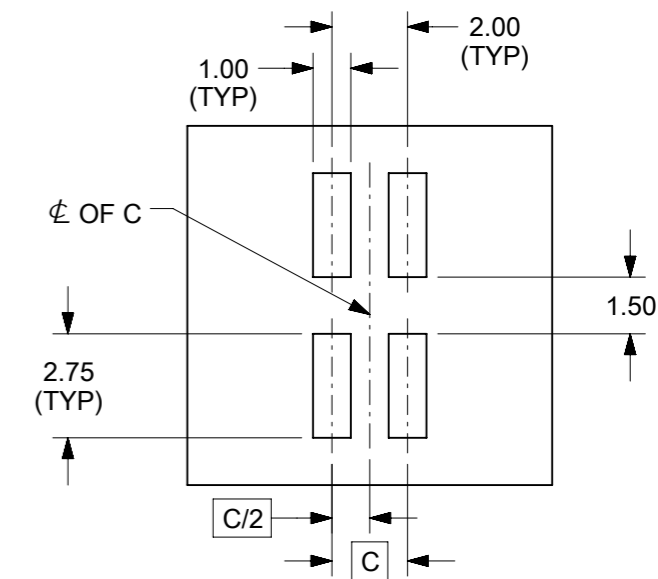

RECOMMENDED PCB LAYOUT

NOTES:

- MATERIALS:**
HOUSING & CAP: 30% GF, NYLON, UL94V-0, COLOR: BLACK
PIN: 0.50mm SQ. PHOSPHOR BRONZE
- FINISHES:** REFER TO PLATING OPTIONS
- PRODUCT SPECIFICATION:** PS-87831-027
- PACKAGING SPECIFICATION:** SEE PACKAGING SPECS TABLE ON SHEET 12
- MATES WITH:** A. MOLEX CRIMP RECEPTACLE HOUSING: 51110 SERIES AND CRIMP TERMINAL: 50394 SERIES
B. MOLEX 2mm MILLIGRID DUAL ROW IDT: 87568 SERIES
C. MOLEX 2mm MILLIGRID DUAL ROW RECEPTACLE: 79107 (GOLD PLATED), 78787 (TIN PLATED)
- COPLANARITY IS TO BE MEASURED BY RESTING THE SOLDER TAIL ON A GAUGE SURFACE
- BEND DEPRESSION ON SMT TAIL IS ACCEPTABLE SO LONG AS IT DOES NOT AFFECT THE OVERALL COPLANARITY
- TOP SURFACE OF CAP TO BE FLAT FOR THE PURPOSE OF PICK & PLACE BY VACUUM SUCTION NOZZLE

THIS DRAWING CONTAINS INFORMATION THAT IS PROPRIETARY TO MOLEX ELECTRONIC TECHNOLOGIES, LLC AND SHOULD NOT BE USED WITHOUT WRITTEN PERMISSION

ADDED BTB DIST. EC NO: 621140 DRWN: NMANE02 CHK'D: NMANE02 REV APPR: MRAMAKRISHNA	2019/07/23	2019/07/23	2019/07/23	GENERAL TOLERANCES (UNLESS SPECIFIED)		DIMENSION UNITS		SCALE		
				MM	INCH	MM	NTS			
	4 PLACES	±	±	DRWN BY		DATE				
	3 PLACES	±	±	GMENARLY		2015/05/22				
			2 PLACES	± 0.2	±	CHK'D BY		DATE		MILLIGRID 2MM PITCH, SMT VERTICAL SHROUDED HEADER
			1 PLACES	±	±	CGOH		2015/09/21		
			0 PLACES	±	±	APPR BY		DATE		
						KHLIM		2015/09/22		
			ANGULAR TOL = 3.0			DRAWING SIZE	THIRD ANGLE PROJECTION			
			DRAFT WHERE APPLICABLE MUST REMAIN WITHIN DIMENSIONS			A3				
			SERIES		MATERIAL NUMBER		CUSTOMER			
			87832		SEE TABLE		GENERAL MARKET			
			DOCUMENT NUMBER			DOC TYPE	DOC PART	SHEET NUMBER		
			SD-87832-0001			PSD	001	2 OF 13		

4 CIRCUITS

CKT SIZE	ASSY P/N WITHOUT CAP IN TUBE	ASSY P/N WITH CAP IN TUBE	ASSY P/N WITH CAP IN T&R	T&R OPTIONS (SEE SHEET 12)	PLATING OPTIONS	FRICTION LOCKS		DUAL SIDE SLOTS	CENTER POLARIZATION	PEGS	DIMENSION							
						DUAL	CENTER				A	B	C	D	E	F	G (COPLAN)	H
4	87832-0460	87832-0462	87832-5162	1	1	N.A	N.A	YES	N.A	N.A	6.65	4.85	2.00	N.A	N.A	5.00	0.10	3.60±0.20
	87832-0420	87832-0422	87832-5122	1	2													
	87832-0421	87832-0423	87832-5123	1	3													
	87832-0470	87832-0472	87832-5172	1	4													
	87832-0410	87832-0408	87832-0406	1	2	N.A	YES	YES	N.A	N.A							0.10	
			87832-5106	2	2													
	87832-0411	87832-0409	87832-0407	1	3	N.A	YES	YES	N.A	N.A								
87832-0404	N.A	N.A	N.A	2	0.10													

PLATING OPTIONS:

- 1 - 0.05-0.13µm/2-5µin GOLD IN CONTACT AREA AND 1.88µm/75µin MIN. MATTE TIN IN SOLDER TAIL AREA OVER 1.27µm/50µin MIN. NICKEL OVERALL.
- 2 - 0.38µm/15µin MIN. GOLD IN CONTACT AREA AND 1.88µm/75µin MIN. MATTE TIN IN SOLDER TAIL AREA OVER 1.27µm/50µin MIN. NICKEL OVERALL.
- 3 - 0.76µm/30µin MIN. GOLD IN CONTACT AREA AND 1.88µm/75µin MIN. MATTE TIN IN SOLDER TAIL AREA OVER 1.27µm/50µin MIN. NICKEL OVERALL.
- 4 - 2.50µm/100µin MIN. MATTE TIN OVER 1.25µm/50µin MIN. NICKEL OVERALL.

THIS DRAWING CONTAINS INFORMATION THAT IS PROPRIETARY TO MOLEX ELECTRONIC TECHNOLOGIES, LLC AND SHOULD NOT BE USED WITHOUT WRITTEN PERMISSION

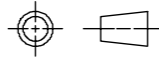
ADDED BTB DIST. EC NO: 621140 DRWN: NMANE02 CHKD: NMANE02 REV APPR: MRAMAKRISHNA	2019/07/23		2019/07/23		2019/07/23		GENERAL TOLERANCES (UNLESS SPECIFIED)		DIMENSION UNITS		SCALE		 MILLIGRID 2MM PITCH, SMT VERTICAL SHROUDED HEADER		
	4 PLACES		±	±	MM		INCH		MM		NTS				
	3 PLACES		±	±	DRWN BY		DATE		GMENARLY		2015/05/22		PRODUCT CUSTOMER DRAWING		
	2 PLACES		± 0.2	±	CHK'D BY		DATE		CGOH		2015/09/21				
	1 PLACES		±	±	APPR BY		DATE		KHLIM		2015/09/22		SERIES: 87832 MATERIAL NUMBER: SEE TABLE CUSTOMER: GENERAL MARKET		
	0 PLACES		±	±	DRAWING SIZE		THIRD ANGLE PROJECTION		A3						
ANGULAR TOL = 3.0		DRAFT WHERE APPLICABLE MUST REMAIN WITHIN DIMENSIONS		DOCUMENT NUMBER		DOC TYPE		DOC PART		SHEET NUMBER		3 OF 13			
A12		SD-87832-0001		PSD		001		3 OF 13							

RELEASE STATUS	P1	RELEASE DATE	2019/07/23	11:08:01
----------------	----	--------------	------------	----------

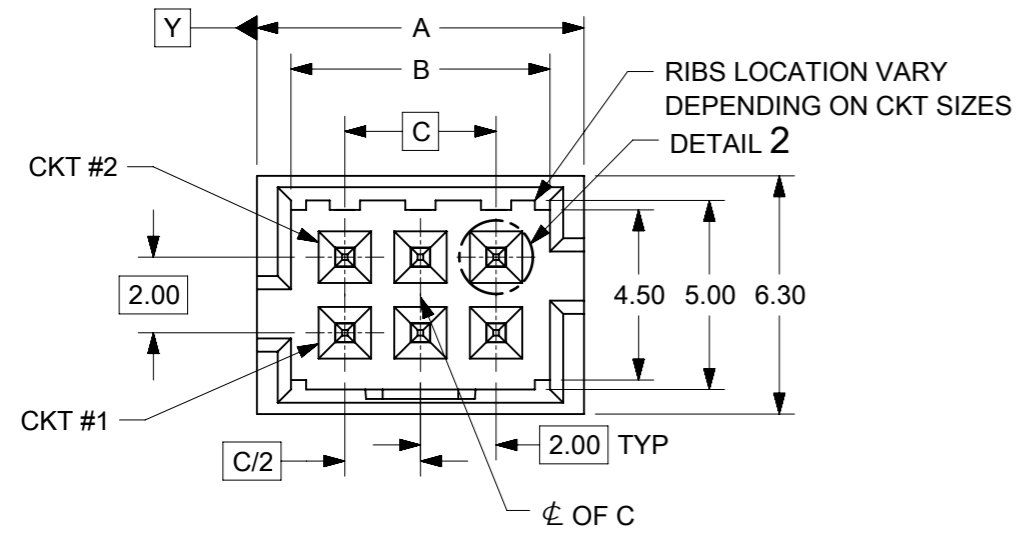

6 CIRCUITS

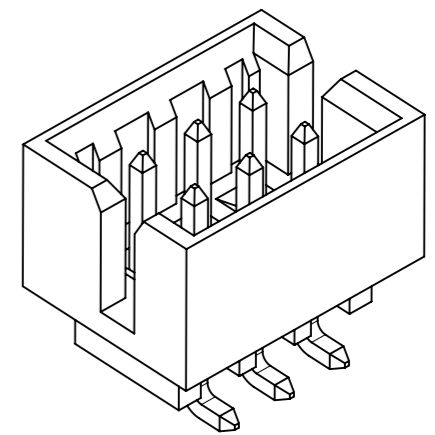
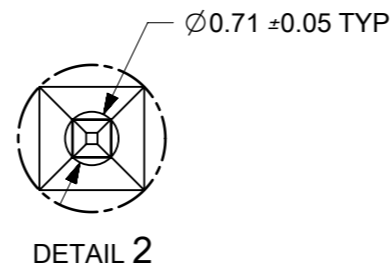

VIEW FOR HEADER WITH ONLY DUAL SLOTS

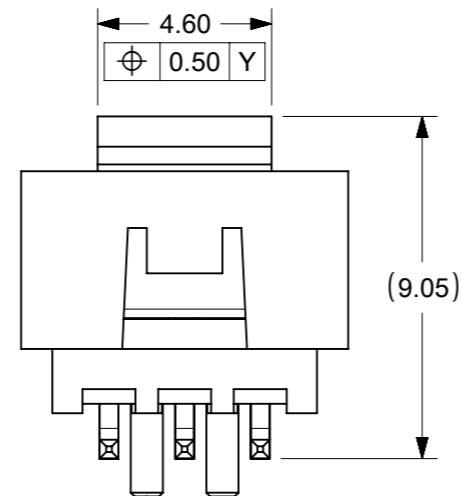
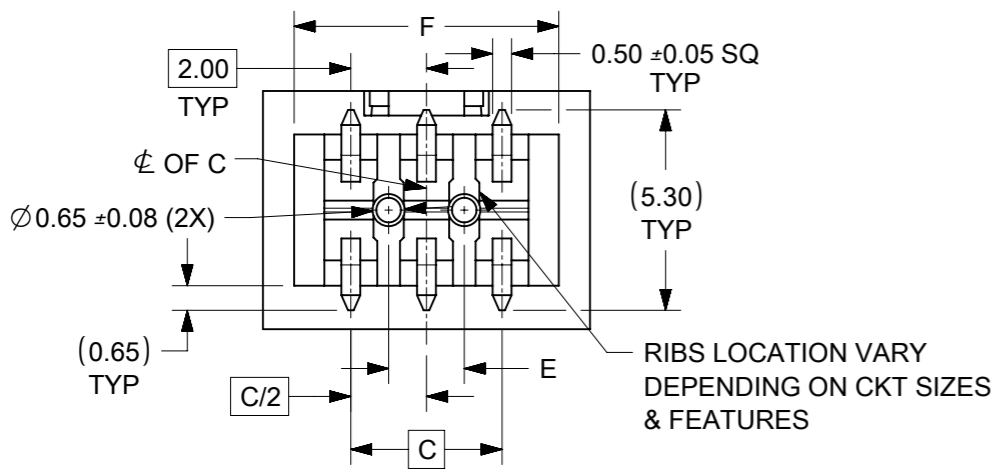
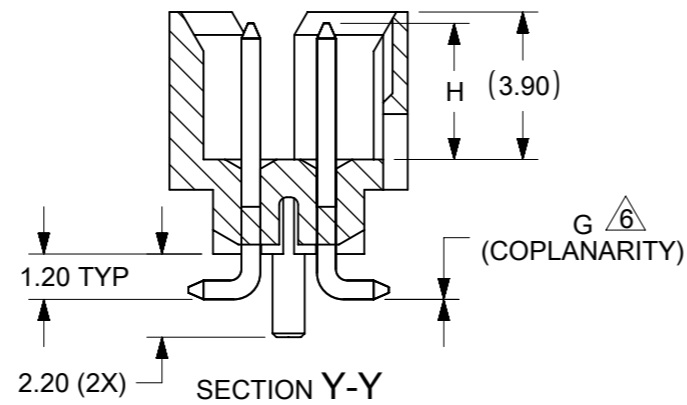
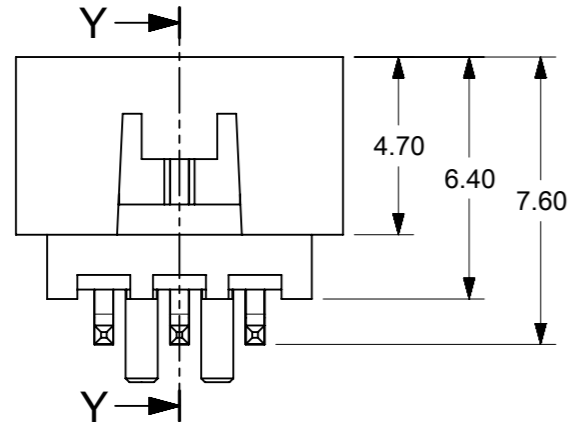

VIEW FOR HEADER WITH CAP

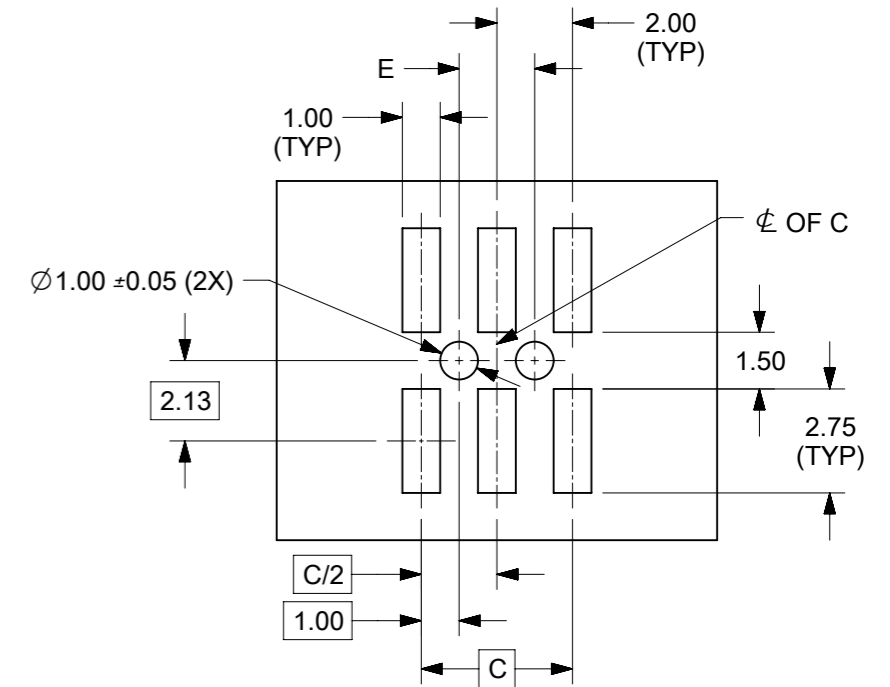
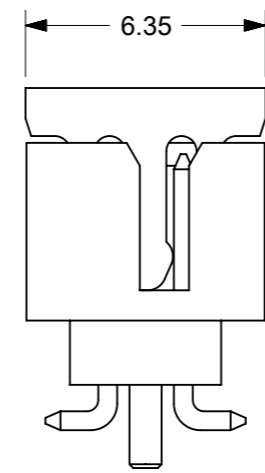

RECOMMENDED PCB LAYOUT

- NOTES:**
- MATERIALS:**
HOUSING & CAP: 30% GF, NYLON, UL94V-0, COLOR: BLACK
PIN: 0.50mm SQ. PHOSPHOR BRONZE
 - FINISHES:** REFER TO PLATING OPTIONS
 - PRODUCT SPECIFICATION:** PS-87831-027
 - PACKAGING SPECIFICATION:** SEE PACKAGING SPECS TABLE ON SHEET 12
 - MATES WITH:** A. MOLEX CRIMP RECEPTACLE HOUSING: 51110 SERIES AND CRIMP TERMINAL: 50394 SERIES
B. MOLEX 2mm MILLIGRID DUAL ROW IDT: 87568 SERIES
C. MOLEX 2mm MILLIGRID DUAL ROW RECEPTACLE: 79107 (GOLD PLATED), 78787 (TIN PLATED)
- 6** COPLANARITY IS TO BE MEASURED BY RESTING THE SOLDER TAIL ON A GAUGE SURFACE
7. BEND DEPRESSION ON SMT TAIL IS ACCEPTABLE SO LONG AS IT DOES NOT AFFECT THE OVERALL COPLANARITY
8. TOP SURFACE OF CAP TO BE FLAT FOR THE PURPOSE OF PICK & PLACE BY VACUUM SUCTION NOZZLE

THIS DRAWING CONTAINS INFORMATION THAT IS PROPRIETARY TO MOLEX ELECTRONIC TECHNOLOGIES, LLC AND SHOULD NOT BE USED WITHOUT WRITTEN PERMISSION

EC NO: 621140 DRWN: NMANE02 CHK'D: NMANE02 APPR: MIRAMAKRISHNA	2019/07/23	2019/07/23	GENERAL TOLERANCES (UNLESS SPECIFIED)		DIMENSION UNITS	SCALE					
	2019/07/23	2019/07/23	MM	INCH	MM	NTS					
	4 PLACES	±	±	DRWN BY	DATE	GMENARLY	2015/05/22	MILLIGRID 2MM PITCH, SMT VERTICAL SHROUDED HEADER			
	3 PLACES	±	±	CHK'D BY	DATE	CGOH	2015/09/21				
	2 PLACES	±	0.2	±	APPR BY	DATE	KHLIM	2015/09/22	PRODUCT CUSTOMER DRAWING		
1 PLACES	±	±	0 PLACES	±	±	DRAWING SIZE		THIRD ANGLE PROJECTION	SERIES	MATERIAL NUMBER	CUSTOMER
ANGULAR TOL = 3.0		DRAFT WHERE APPLICABLE MUST REMAIN WITHIN DIMENSIONS		A3			87832	SEE TABLE	GENERAL MARKET		
RELEASE STATUS	P1	RELEASE DATE	2019/07/23	11:08:01	DOCUMENT NUMBER		SD-87832-0001	DOC TYPE	DOC PART	SHEET NUMBER	
					A12		PSD	001	4 OF 13		

6 CIRCUITS

CKT SIZE	ASSY P/N WITHOUT CAP IN TUBE	ASSY P/N WITH CAP IN TUBE	ASSY P/N WITH CAP IN T&R	T&R OPTIONS (SEE SHEET 12)	PLATING OPTIONS	FRICTION LOCKS		DUAL SIDE SLOTS	CENTER POLARIZATION	PEGS	DIMENSION							
						DUAL	CENTER				A	B	C	D	E	F	G (COPLAN)	H
6	87832-0660	87832-0662	87832-5262	1	1	N.A	N.A	YES	N.A	YES	8.65	6.85	4.00	N.A	2.00	7.00	0.10	3.60±0.20
	87832-0620	87832-0622	87832-5222	1	2												0.10	3.60±0.20
	87832-0621	87832-0623	87832-5223	1	3												0.10	3.60±0.15
	87832-0670	87832-0672	87832-5272	1	4												0.10	3.60±0.20
	87832-0612	87832-0616	87832-0614	1	2	N.A	N.A	YES	N.A	N.A							0.10	3.60±0.20
	87832-0613	87832-0617	87832-0615	1	3	N.A	N.A	YES	YES	N.A							0.10	3.60±0.20
	87832-0624	87832-0626	87832-0628	1	2	N.A	YES	YES	N.A	N.A							0.10	3.60±0.20
	87832-0625	87832-0627	87832-0629	1	3	N.A	YES	YES	N.A	YES							0.10	3.60±0.20
	87832-0610	87832-0608	87832-0606	1	2	N.A	YES	YES	N.A	YES							0.10	3.60±0.20
	87832-0611	87832-0609	87832-0607	1	3	N.A	YES	YES	N.A	YES							0.10	3.60±0.20
87832-0604	N.A	N.A	N.A	2	N.A	YES	YES	N.A	YES	0.10	3.60±0.20							

PLATING OPTIONS:

- 1 - 0.05-0.13µm/2-5µin GOLD IN CONTACT AREA AND
1.88µm/75µin MIN. MATTE TIN IN SOLDER TAIL AREA OVER
1.27µm/50µin MIN. NICKEL OVERALL.
- 2 - 0.38µm/15µin MIN. GOLD IN CONTACT AREA AND
1.88µm/75µin MIN. MATTE TIN IN SOLDER TAIL AREA OVER
1.27µm/50µin MIN. NICKEL OVERALL.
- 3 - 0.76µm/30µin MIN. GOLD IN CONTACT AREA AND
1.88µm/75µin MIN. MATTE TIN IN SOLDER TAIL AREA OVER
1.27µm/50µin MIN. NICKEL OVERALL.
- 4 - 2.50µm/100µin MIN. MATTE TIN OVER 1.25µm/50µin MIN. NICKEL OVERALL.

THIS DRAWING CONTAINS INFORMATION THAT IS PROPRIETARY TO MOLEX ELECTRONIC TECHNOLOGIES, LLC AND SHOULD NOT BE USED WITHOUT WRITTEN PERMISSION

ADDED BTB DIST. EC NO: 621140 DRWN: NMANE02 CHKD: NMANE02 REV APPR: MRAMAKRISHNA	2019/07/23	GENERAL TOLERANCES (UNLESS SPECIFIED)		DIMENSION UNITS	SCALE				
	2019/07/23	MM	INCH	MM	NTS				
	2019/07/23	4 PLACES ±	±	DRWN BY	DATE	MILLIGRID 2MM PITCH, SMT VERTICAL SHROUDED HEADER			
	2019/07/23	3 PLACES ±	±	GMENARLY	2015/05/22				
	2019/07/23	2 PLACES ± 0.2	±	CHK'D BY	DATE	PRODUCT CUSTOMER DRAWING			
	2019/07/23	1 PLACES ±	±	CGOH	2015/09/21				
2019/07/23	0 PLACES ±	±	APPR BY	DATE	SERIES	MATERIAL NUMBER	CUSTOMER		
2019/07/23	ANGULAR TOL = 3.0	±	KHLIM	2015/09/22	87832	SEE TABLE	GENERAL MARKET		
2019/07/23	DRAFT WHERE APPLICABLE MUST REMAIN WITHIN DIMENSIONS	±	DRAWING SIZE	THIRD ANGLE PROJECTION	DOCUMENT NUMBER				
2019/07/23	A12	±	A3		SD-87832-0001		DOC TYPE	DOC PART	SHEET NUMBER
					PSD	001	5 OF 13		

RELEASE STATUS	P1	RELEASE DATE	2019/07/23	11:08:01
----------------	----	--------------	------------	----------

8 TO 12 CIRCUITS

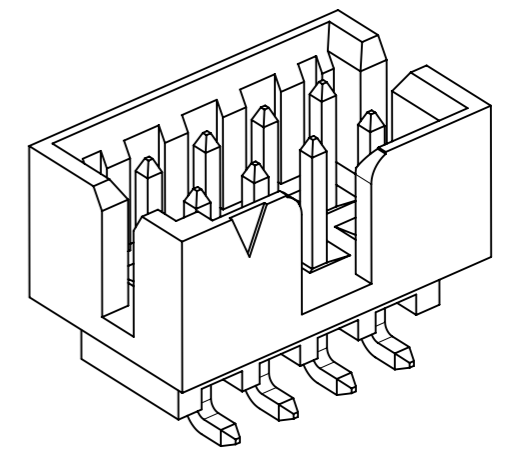
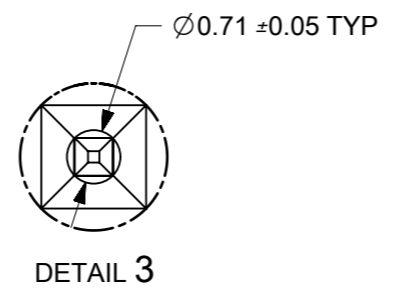
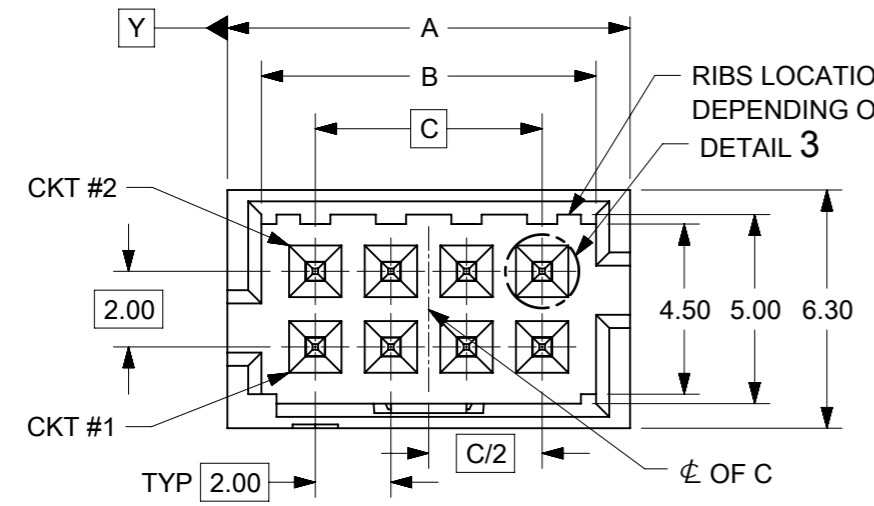

ISO VIEW OF HEADER WITH CENTER POLARIZATION AND DUAL SIDE SLOTS

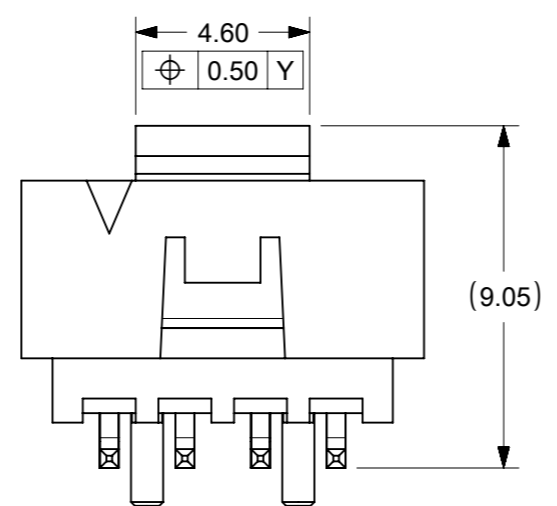
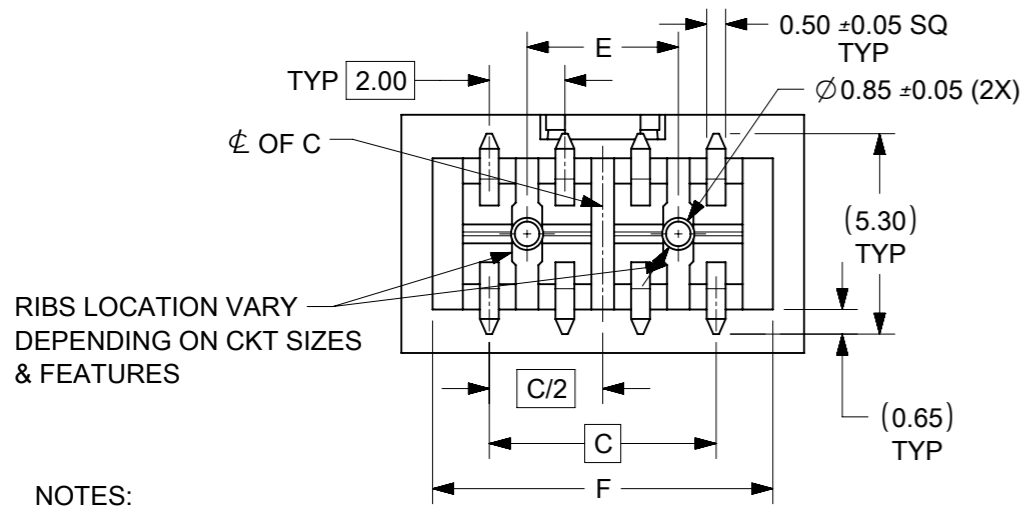
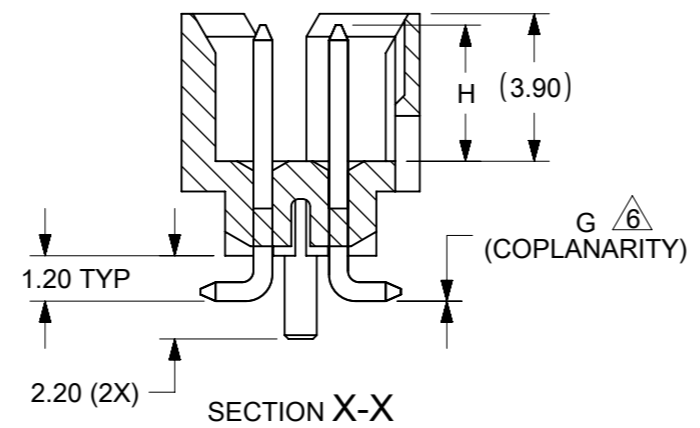
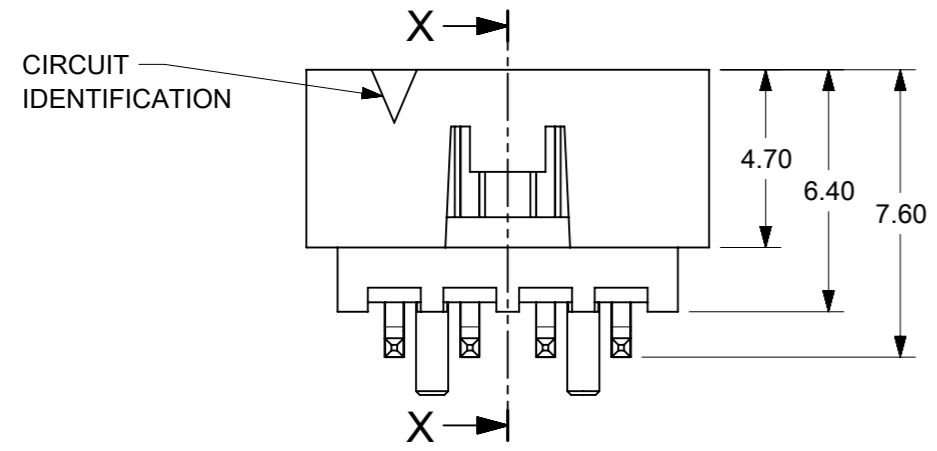

VIEW FOR HEADER WITH CAP

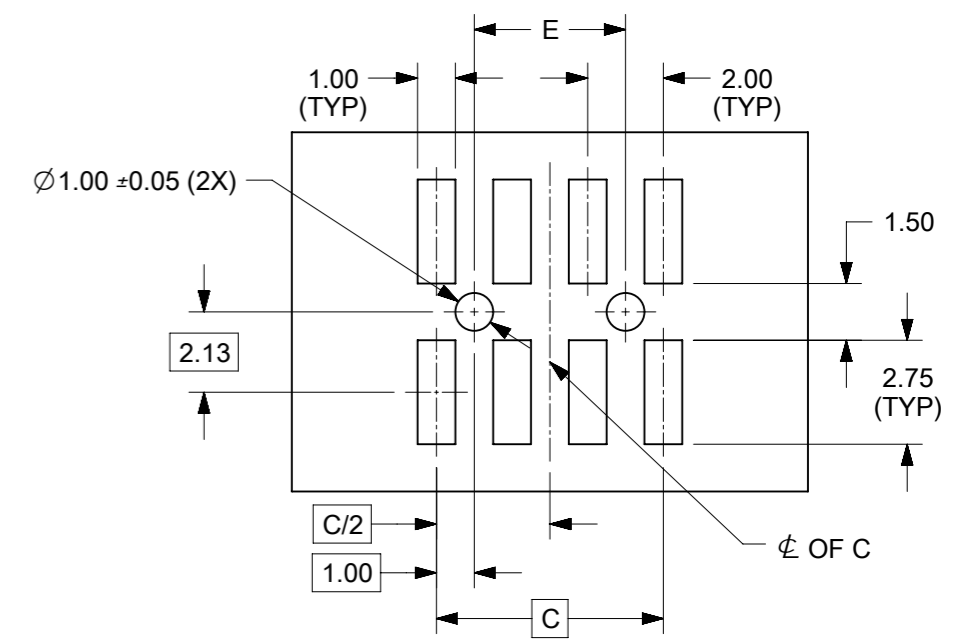

RECOMMENDED PCB LAYOUT

- NOTES:
1. MATERIALS:
HOUSING & CAP: 30% GF, NYLON, UL94V-0, COLOR: BLACK
PIN: 0.50mm SQ. PHOSPHOR BRONZE
 2. FINISHES: REFER TO PLATING OPTIONS
 3. PRODUCT SPECIFICATION: PS-87831-027
 4. PACKAGING SPECIFICATION: SEE PACKAGING SPECS TABLE ON SHEET 12
 5. MATES WITH: A. MOLEX CRIMP RECEPTACLE HOUSING: 51110 SERIES AND CRIMP TERMINAL: 50394 SERIES
B. MOLEX 2mm MILLIGRID DUAL ROW IDT: 87568 SERIES
C. MOLEX 2mm MILLIGRID DUAL ROW RECEPTACLE: 79107 (GOLD PLATED), 78787 (TIN PLATED)
 6. COPLANARITY IS TO BE MEASURED BY RESTING THE SOLDER TAIL ON A GAUGE SURFACE
 7. BEND DEPRESSION ON SMT TAIL IS ACCEPTABLE SO LONG AS IT DOES NOT AFFECT THE OVERALL COPLANARITY
 8. TOP SURFACE OF CAP TO BE FLAT FOR THE PURPOSE OF PICK & PLACE BY VACUUM SUCTION NOZZLE

THIS DRAWING CONTAINS INFORMATION THAT IS PROPRIETARY TO MOLEX ELECTRONIC TECHNOLOGIES, LLC AND SHOULD NOT BE USED WITHOUT WRITTEN PERMISSION

ADDED BTB DIST. EC NO: 621140 DRWN: NMANE02 CHK'D: NMANE02 REV APPR: MIRAMAKRISHNA	2019/07/23	2019/07/23	2019/07/23	GENERAL TOLERANCES (UNLESS SPECIFIED)		DIMENSION UNITS		SCALE										
				MM	INCH	MM	NTS	MM	NTS									
				4 PLACES	±	±	DRWN BY	DATE	GMENARLY		2015/05/22							
				3 PLACES	±	±	CHK'D BY	DATE	CGOH		2015/09/21							
			2 PLACES	±	0.2	±	APPR BY	DATE	KHLIM		2015/09/22							
			1 PLACES	±	±	DRAWING SIZE		THIRD ANGLE PROJECTION		SERIES		MATERIAL NUMBER		CUSTOMER				
			0 PLACES	±	±	A3				87832		SEE TABLE		GENERAL MARKET				
			ANGULAR TOL = 3.0		DRAFT WHERE APPLICABLE MUST REMAIN WITHIN DIMENSIONS						DOCUMENT NUMBER		DOC TYPE		DOC PART		SHEET NUMBER	
											SD-87832-0001		PSD		001		6 OF 13	

8 TO 12 CIRCUITS

CKT SIZE	ASSY P/N WITHOUT CAP IN TUBE	ASSY P/N WITH CAP IN TUBE	ASSY P/N WITH CAP IN T&R	T&R OPTIONS (SEE SHEET 12)	PLATING OPTIONS	FRICTION LOCKS		DUAL SIDE SLOTS	CENTER POLARIZATION	PEGS	DIMENSION							
						DUAL	CENTER				A	B	C	D	E	F	G (COPLAN)	H
8	87832-0860	87832-0862	87832-5362	1	1	N.A	N.A	YES	YES	YES	10.65	8.85	6.00	N.A	4.00	9.00	0.10	3.60±0.20
	87832-0820	87832-0822	87832-5322	1	2													
	87832-0821	87832-0823	87832-5323	1	3													
	87832-0870	87832-0872	87832-5372	1	4	N.A	N.A	YES	YES	N.A							0.10	3.60±0.20
	87832-0812	87832-0816	87832-0814	1	2													
	87832-0824	87832-0826	87832-0828	1	2	N.A	YES	YES	N.A	N.A							0.10	3.60±0.15
	87832-0825	87832-0827	87832-0829	1	3													
	87832-0810	87832-0808	87832-0806	1	2	N.A	YES	YES	N.A	YES							0.10	3.60±0.20
	87832-0811	87832-0809	87832-0807	1	3													
87832-0804	N.A	N.A	N.A	2	N.A	YES	YES	N.A	YES	0.10	3.60±0.20							
10	87832-1060	87832-1062	87832-5462	1	1	N.A	N.A	YES	YES	YES	12.65	10.85	8.00	N.A	6.00	11.00	0.10	3.60±0.20
	87832-1020	87832-1022	87832-5422	1	2													
	87832-1021	87832-1023	87832-5423	1	3													
			87832-9423	2														
	87832-1070	87832-1072	87832-5472	1	4	N.A	N.A	YES	YES	N.A							0.10	3.60±0.20
	87832-1012	87832-1016	87832-1014	1	2													
	87832-1019	87832-1045	87832-1035	1	1	N.A	YES	YES	N.A	N.A							0.10	3.60±0.15
	87832-1024	87832-1026	87832-1028	1	2													
	N.A	N.A	87832-1055	1	1	N.A	YES	YES	N.A	N.A							0.10	3.60±0.20
	87832-1025	87832-1027	87832-1029	1	3													
87832-1010	87832-1008	87832-1006	1	2	N.A	YES	YES	N.A	YES	0.10	3.60±0.20							
87832-1011	87832-1009	87832-1007	1	3														
87832-1004	N.A	N.A	N.A	2	N.A	YES	YES	N.A	YES	0.10	3.60±0.20							
12	87832-1260	87832-1262	87832-5562	1	1	N.A	N.A	YES	YES	YES	14.65	12.85	10.00	N.A	8.00	13.00	0.10	3.60±0.20
	87832-1220	87832-1222	87832-5522	1	2													
	87832-1221	87832-1223	87832-5523	1	3													
			87832-9623	2														
	87832-1270	87832-1272	87832-5572	1	4	N.A	YES	YES	N.A	N.A							0.10	3.60±0.15
	87832-1224	87832-1226	87832-1228	1	2													
	87832-1225	87832-1227	87832-1229	1	3	N.A	YES	YES	N.A	YES							0.10	3.60±0.20
	87832-1210	87832-1208	87832-1206	1	2													
	87832-1211	87832-1209	87832-1207	1	3	N.A	YES	YES	N.A	YES							0.10	3.60±0.20
87832-1204	N.A	N.A	N.A	2														
87832-1212	N.A	N.A	N.A	2	N.A	N.A	YES	YES	N.A	0.10	3.60±0.20							

PLATING OPTIONS:

- 1 - 0.05-0.13µm/2-5µin GOLD IN CONTACT AREA AND 1.88µm/75µin MIN. MATTE TIN IN SOLDER TAIL AREA OVER 1.27µm/50µin MIN. NICKEL OVERALL.
- 2 - 0.38µm/15µin MIN. GOLD IN CONTACT AREA AND 1.88µm/75µin MIN. MATTE TIN IN SOLDER TAIL AREA OVER 1.27µm/50µin MIN. NICKEL OVERALL.
- 3 - 0.76µm/30µin MIN. GOLD IN CONTACT AREA AND 1.88µm/75µin MIN. MATTE TIN IN SOLDER TAIL AREA OVER 1.27µm/50µin MIN. NICKEL OVERALL.
- 4 - 2.50µm/100µin MIN. MATTE TIN OVER 1.25µm/50µin MIN. NICKEL OVERALL.

THIS DRAWING CONTAINS INFORMATION THAT IS PROPRIETARY TO MOLEX ELECTRONIC TECHNOLOGIES, LLC AND SHOULD NOT BE USED WITHOUT WRITTEN PERMISSION

ADDED BTB DIST. 2019/07/23 2019/07/23 2019/07/23	GENERAL TOLERANCES (UNLESS SPECIFIED)		DIMENSION UNITS		SCALE		molex MILLIGRID 2MM PITCH, SMT VERTICAL SHROUDED HEADER	
			MM	INCH	MM	NTS		
	4 PLACES ±				DRWN BY	DATE		
	3 PLACES ±				GMENARLY	2015/05/22		
EC NO: 621140 DRWN: NMANE02 CHKD: NMANE02 REV APPR: MRAMAKRISHNA	2 PLACES ± 0.2				CHK'D BY	DATE	PRODUCT CUSTOMER DRAWING	
	1 PLACES ±				CGOH	2015/09/21		
	0 PLACES ±				APPR BY	DATE		
					KHLIM	2015/09/22		
ANGULAR TOL = 3.0				DRAWING SIZE	THIRD ANGLE PROJECTION	SERIES MATERIAL NUMBER CUSTOMER		
DRAFT WHERE APPLICABLE MUST REMAIN WITHIN DIMENSIONS				A3		87832	SEE TABLE	GENERAL MARKET
						DOCUMENT NUMBER		DOC TYPE DOC PART SHEET NUMBER
						SD-87832-0001		PSD 001 7 OF 13

RELEASE STATUS	P1	RELEASE DATE	2019/07/23	11:08:01
----------------	----	--------------	------------	----------

14 TO 50 CIRCUITS

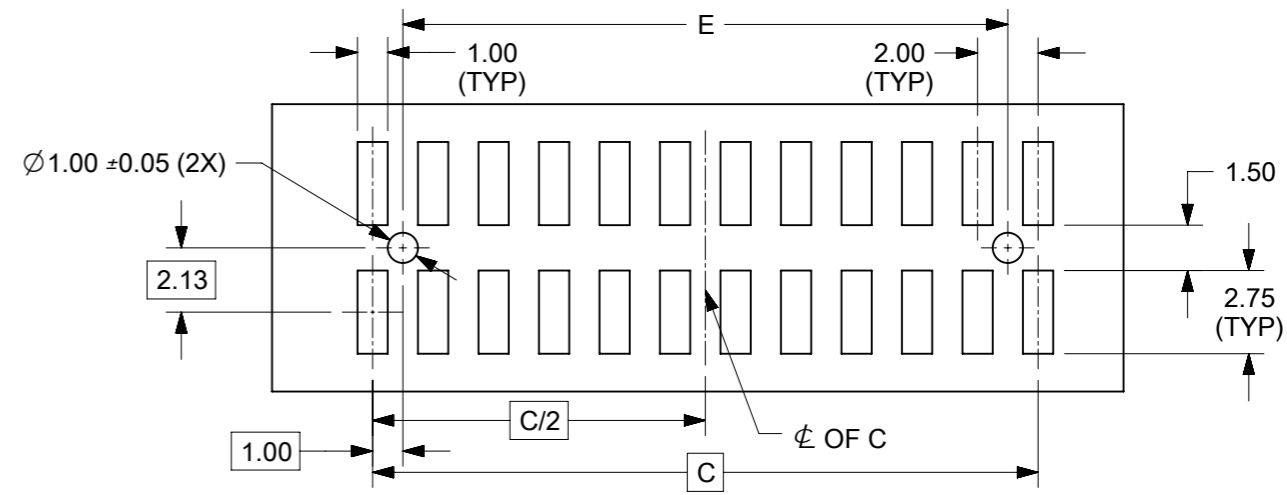
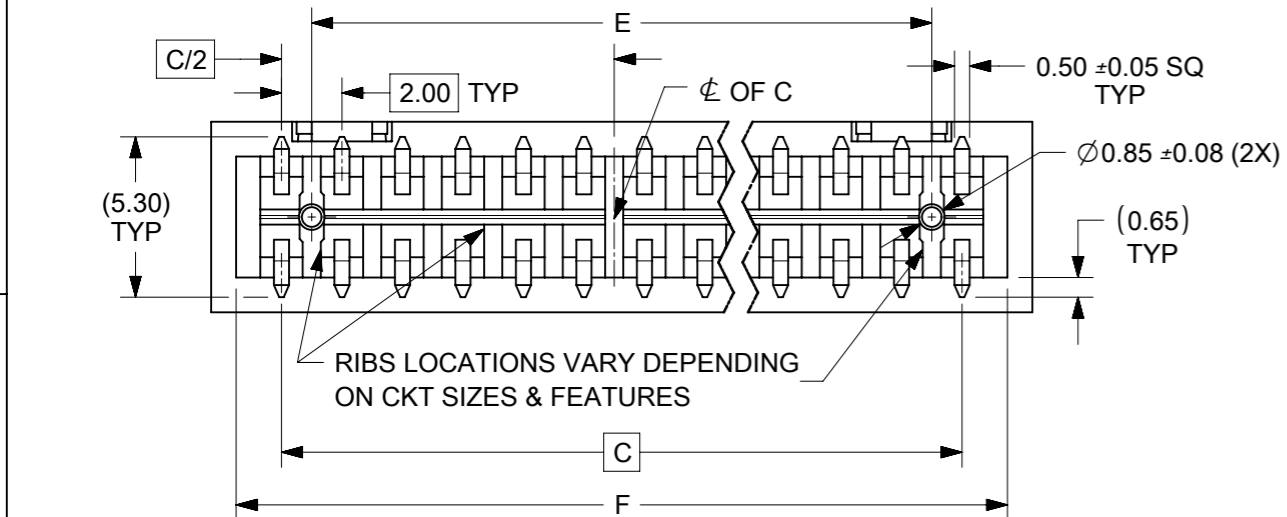
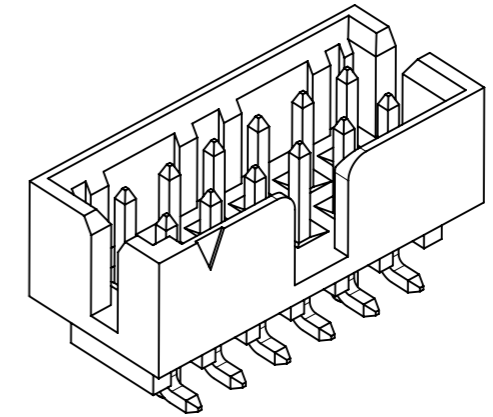
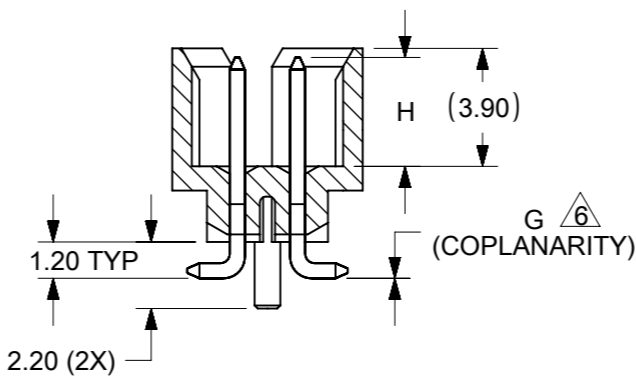
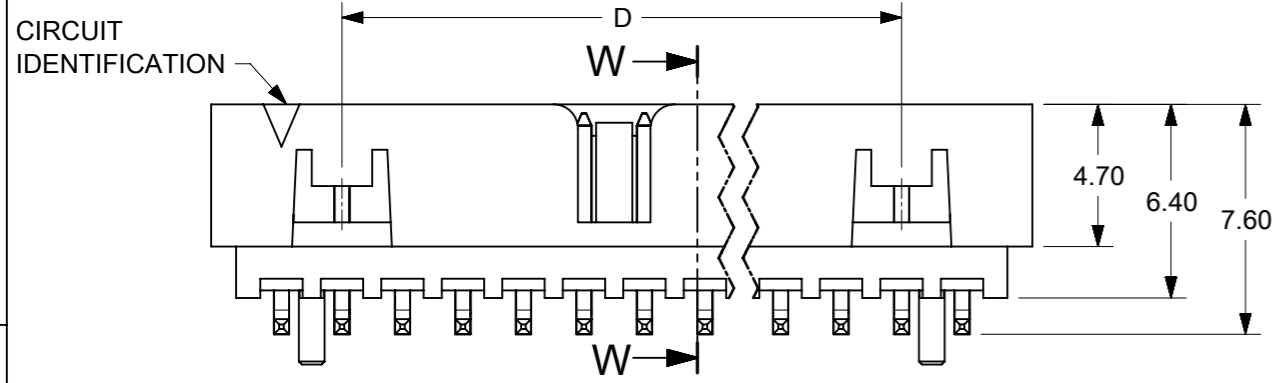
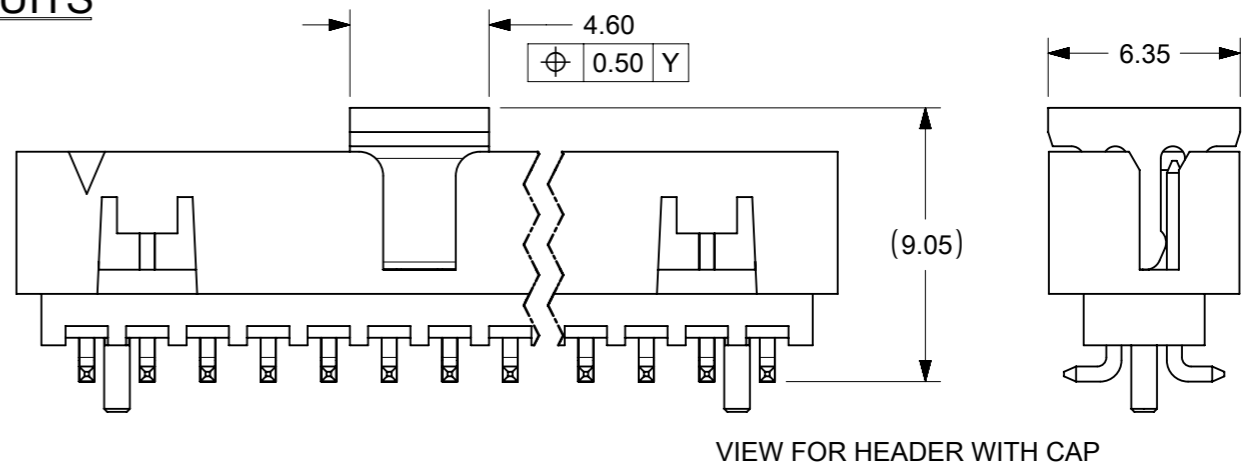
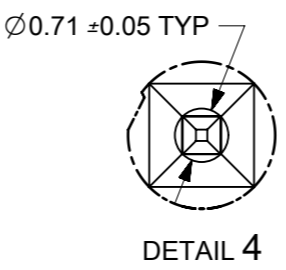
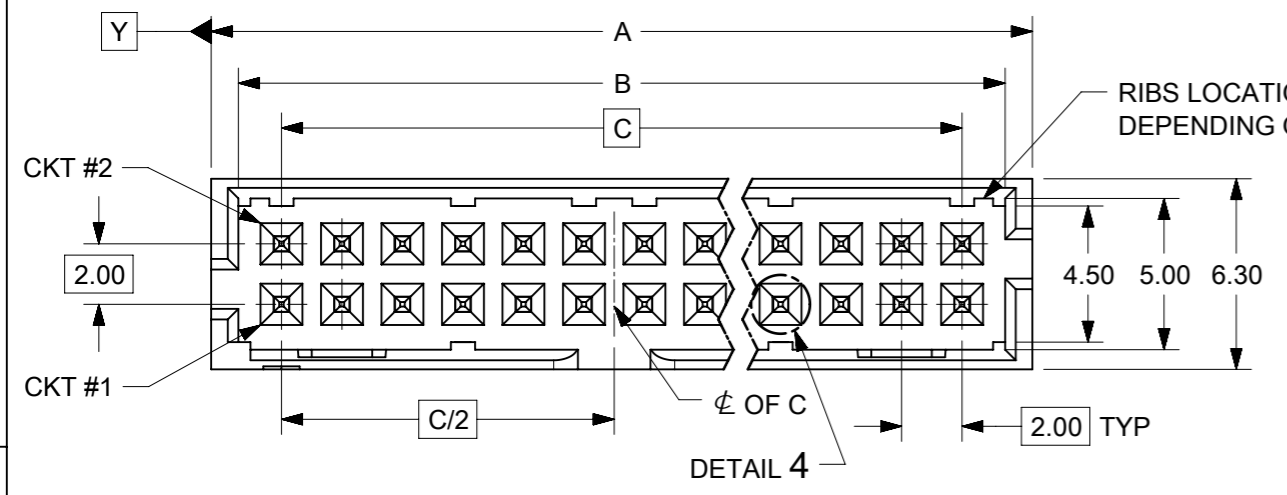

- NOTES:**
- 1. MATERIALS:**
HOUSING & CAP: 30% GF, NYLON, UL94V-0, COLOR: BLACK
PIN: 0.50mm SQ. PHOSPHOR BRONZE
 - 2. FINISHES:** REFER TO PLATING OPTIONS
 - 3. PRODUCT SPECIFICATION:** PS-87831-027
 - 4. PACKAGING SPECIFICATION:** SEE PACKAGING SPECS TABLE ON SHEET 12
 - 5. MATES WITH:** A. MOLEX CRIMP RECEPTACLE HOUSING: 51110 SERIES AND CRIMP TERMINAL: 50394 SERIES
B. MOLEX 2mm MILLIGRID DUAL ROW IDT: 87568 SERIES
C. MOLEX 2mm MILLIGRID DUAL ROW RECEPTACLE: 79107 (GOLD PLATED), 78787 (TIN PLATED)
 - 6. COPLANARITY IS TO BE MEASURED BY RESTING THE SOLDER TAIL ON A GAUGE SURFACE**
 - 7. BEND DEPRESSION ON SMT TAIL IS ACCEPTABLE SO LONG AS IT DOES NOT AFFECT THE OVERALL COPLANARITY**
 - 8. TOP SURFACE OF CAP TO BE FLAT FOR THE PURPOSE OF PICK & PLACE BY VACUUM SUCTION NOZZLE**

THIS DRAWING CONTAINS INFORMATION THAT IS PROPRIETARY TO MOLEX ELECTRONIC TECHNOLOGIES, LLC AND SHOULD NOT BE USED WITHOUT WRITTEN PERMISSION

EC NO: 621140 DRWN: NMANE02 CHKD: NMANE02 APPR: MRAMAKRISHNA	2019/07/23	2019/07/23	2019/07/23	GENERAL TOLERANCES (UNLESS SPECIFIED)		DIMENSION UNITS		SCALE		
				MM	INCH	MM	NTS	DRWN BY DATE		
	4 PLACES	±	±	GMENARLY		2015/05/22		CHK'D BY DATE		
	3 PLACES	±	±	CGOH		2015/09/21		APPR BY DATE		
			2 PLACES	± 0.2	±	KHLIM		2015/09/22		PRODUCT CUSTOMER DRAWING SERIES: 87832 MATERIAL NUMBER: SEE TABLE CUSTOMER: GENERAL MARKET
			1 PLACES	±	±	DRAWING SIZE: A3		THIRD ANGLE PROJECTION		
			0 PLACES	±	±	ANGULAR TOL = 3.0		DRAFT WHERE APPLICABLE MUST REMAIN WITHIN DIMENSIONS		
RELEASE STATUS	P1	RELEASE DATE	2019/07/23	11:08:01						

14 TO 24 CIRCUITS

CKT SIZE	ASSY P/N WITHOUT CAP IN TUBE	ASSY P/N WITH CAP IN TUBE	ASSY P/N WITH CAP IN T&R	T&R OPTIONS (SEE SHEET 12)	PLATING OPTIONS	FRICTION LOCKS		DUAL SIDE SLOTS	CENTER POLARIZATION	PEGS	DIMENSION							
						DUAL	CENTER				A	B	C	D	E	F	G (COPLAN)	H
14	87832-1460	87832-1462	87832-5662	1	1	YES	N.A	YES	YES	YES	16.65	14.85	12.00	8.00	10.00	15.00	0.15	3.60±0.20
	87832-1420	87832-1422	87832-5622	1	2													
	87832-1421	87832-1423	87832-5623	1	3													
			87832-9523	2														
	87832-1470	87832-1472	87832-5672	1	4													
87832-1412	87832-1416	87832-1414	1	2	YES	N.A	YES	YES	N.A	0.15	3.60±0.20							
16	87832-1660	87832-1662	87832-5762	1	1	YES	N.A	YES	YES	YES	18.65	16.85	14.00	10.00	12.00	17.00	0.15	3.60±0.20
	87832-1620	87832-1622	87832-5722	1	2													
	87832-1621	87832-1623	87832-5723	1	3													
	87832-1670	87832-1672	87832-5772	1	4													
	87832-1612	87832-1616	87832-1614	1	2													
(A11) 87832-1619	87832-1645	87832-1635	1	1	YES	N.A	YES	YES	N.A	0.15	3.60±0.20							
18	87832-1860	87832-1862	87832-5862	1	1	YES	N.A	YES	YES	YES	20.65	18.85	16.00	12.00	14.00	19.00	0.15	3.60±0.20
	87832-1820	87832-1822	87832-5822	1	2													
	87832-1821	87832-1823	87832-5823	1	3													
	87832-1870	87832-1872	87832-5872	1	4													
	87832-1812	87832-1816	87832-1814	3	2													
87832-1813	87832-1817	87832-1815	3	3	YES	N.A	YES	YES	N.A	0.15	3.60±0.20							
20	87832-2060	87832-2062	87832-5962	1	1	YES	N.A	YES	YES	YES	22.65	20.85	18.00	14.00	16.00	21.00	0.15	3.60±0.20
	87832-2020	87832-2022	87832-5922	1	2													
	87832-2021	87832-2023	87832-5923	1	3													
	87832-2070	87832-2072	87832-5972	1	4													
			87832-9672	2														
87832-2012	87832-2016	87832-2014	1	2	YES	N.A	YES	YES	N.A	0.15	3.60±0.20							
22	87832-2260	87832-2262	87832-6062	1	1	YES	N.A	YES	YES	YES	24.65	22.85	20.00	16.00	18.00	23.00	0.15	3.60±0.20
	87832-2220	87832-2222	87832-6022	1	2													
	87832-2221	87832-2223	87832-6023	1	3													
	87832-2270	87832-2272	87832-6072	1	4													
24	87832-2460	87832-2462	87832-6162	1	1	YES	N.A	YES	YES	YES	26.65	24.85	22.00	18.00	20.00	25.00	0.15	3.60±0.20
	87832-2420	87832-2422	87832-6122	1	2													
	87832-2421	87832-2423	87832-6123	1	3													
	87832-2470	87832-2472	87832-6172	1	4													
	87832-2412	87832-2416	87832-2414	1	2													

PLATING OPTIONS:

- 1 - 0.05-0.13µm/2-5µin GOLD IN CONTACT AREA AND 1.88µm/75µin MIN. MATTE TIN IN SOLDER TAIL AREA OVER 1.27µm/50µin MIN. NICKEL OVERALL.
- 2 - 0.38µm/15µin MIN. GOLD IN CONTACT AREA AND 1.88µm/75µin MIN. MATTE TIN IN SOLDER TAIL AREA OVER 1.27µm/50µin MIN. NICKEL OVERALL.
- 3 - 0.76µm/30µin MIN. GOLD IN CONTACT AREA AND 1.88µm/75µin MIN. MATTE TIN IN SOLDER TAIL AREA OVER 1.27µm/50µin MIN. NICKEL OVERALL.
- 4 - 2.50µm/100µin MIN. MATTE TIN OVER 1.25µm/50µin MIN. NICKEL OVERALL.

THIS DRAWING CONTAINS INFORMATION THAT IS PROPRIETARY TO MOLEX ELECTRONIC TECHNOLOGIES, LLC AND SHOULD NOT BE USED WITHOUT WRITTEN PERMISSION

ADDED BTB DIST. EC NO: 621140 DRWN: NMANE02 CHK'D: NMANE02 APPR: MRAMAKRISHNA	GENERAL TOLERANCES (UNLESS SPECIFIED)		DIMENSION UNITS		SCALE		MILLIGRID 2MM PITCH, SMT VERTICAL SHROUDED HEADER						
			MM	INCH	MM	NTS							
	4 PLACES ±				DRWN BY	DATE		PRODUCT CUSTOMER DRAWING SERIES: 87832 MATERIAL NUMBER: SEE TABLE CUSTOMER: GENERAL MARKET					
	3 PLACES ±				GMENARLY	2015/05/22							
	2 PLACES ± 0.2				CHK'D BY	DATE							
1 PLACES ±				CGOH	2015/09/21								
0 PLACES ±				APPR BY	DATE								
				KHLIM	2015/09/22								
ANGULAR TOL = 3.0				DRAWING SIZE	THIRD ANGLE PROJECTION								
DRAFT WHERE APPLICABLE MUST REMAIN WITHIN DIMENSIONS				A3									
						DOCUMENT NUMBER		DOC TYPE		DOC PART		SHEET NUMBER	
						SD-87832-0001		PSD		001		9 OF 13	

26 TO 38 CIRCUITS

CKT SIZE	ASSY P/N WITHOUT CAP IN TUBE	ASSY P/N WITH CAP IN TUBE	ASSY P/N WITH CAP IN T&R	T&R OPTIONS (SEE SHEET 12)	PLATING OPTIONS	FRICTION LOCKS		DUAL SIDE SLOTS	CENTER POLARIZATION	PEGS	DIMENSION												
						DUAL	CENTER				A	B	C	D	E	F	G (COPLAN)	H					
26	87832-2660	87832-2662	87832-6262	1	1	YES	N.A	YES	YES	YES	28.65	26.85	24.00	20.00	22.00	27.00	0.15	3.60±0.20					
	87832-2620	87832-2622	87832-6222	1	2																		
	87832-2621	87832-2623	87832-6223	1	3																		
	87832-2670	87832-2672	87832-6272	1	4																		
	87832-2612	87832-2616	N.A	N.A	2												YES	N.A	YES	YES	N.A	0.15	3.60±0.20
87832-2619	87832-2645	87832-2635	1	1																			
28	87832-2860	87832-2862	87832-6362	1	1	YES	N.A	YES	YES	YES	30.65	28.85	26.00	22.00	24.00	29.00	0.15	3.60±0.20					
	87832-2820	87832-2822	87832-6322	1	2																		
	87832-2821	87832-2823	87832-6323	1	3																		
	87832-2870	87832-2872	87832-6372	1	4																		
	N.A	87832-2816	N.A	1	2												YES	N.A	YES	YES	N.A	0.15	3.60±0.20
N.A	87832-2819	N.A	1	1																			
30	87832-3060	87832-3062	87832-6462	1	1	YES	N.A	YES	YES	YES	32.65	30.85	28.00	24.00	26.00	31.00	0.15	3.60±0.20					
	87832-3020	87832-3022	87832-6422	1	2																		
	87832-3021	87832-3023	87832-6423	1	3																		
	87832-3070	87832-3072	87832-6472	1	4																		
	87832-3012	87832-3016	87832-3014	3	2												YES	N.A	YES	YES	N.A	0.15	3.60±0.20
87832-3260	87832-3262	87832-6562	1	1																			
32	87832-3220	87832-3222	87832-6522	1	2	YES	N.A	YES	YES	YES	34.65	32.85	30.00	26.00	28.00	33.00	0.15	3.60±0.20					
	87832-3221	87832-3223	87832-6523	1	3																		
	87832-3270	87832-3272	87832-6572	1	4																		
	87832-3460	87832-3462	87832-6662	1	1																		
34	87832-3420	87832-3422	87832-6622	1	2	YES	N.A	YES	YES	YES	36.65	34.85	32.00	28.00	30.00	35.00	0.15	3.60±0.20					
	87832-3421	87832-3423	87832-6623	1	3																		
	87832-3470	87832-3472	87832-6672	1	4																		
	87832-3412	87832-3416	87832-3414	3	2														YES	N.A	YES	YES	N.A
	87832-3419	87832-3445	87832-3435	3	1																		
36	87832-3660	87832-3662	N.A	N.A	1	YES	N.A	YES	YES	YES	38.65	36.85	34.00	30.00	32.00	37.00	0.15	3.60±0.20					
	87832-3620	87832-3622	N.A	N.A	2																		
	87832-3621	87832-3623	N.A	N.A	3																		
	87832-3670	87832-3672	N.A	N.A	4																		
38	87832-3860	87832-3862	N.A	N.A	1	YES	N.A	YES	YES	YES	40.65	38.85	36.00	32.00	34.00	39.00	0.15	3.60±0.20					
	87832-3820	87832-3822	87832-6822	N.A	2																		
	87832-3821	87832-3823	N.A	N.A	3																		
	87832-3870	87832-3872	N.A	N.A	4																		

PLATING OPTIONS:

- 0.05-0.13µm/2-5µin GOLD IN CONTACT AREA AND 1.88µm/75µin MIN. MATTE TIN IN SOLDER TAIL AREA OVER 1.27µm/50µin MIN. NICKEL OVERALL.
- 0.38µm/15µin MIN. GOLD IN CONTACT AREA AND 1.88µm/75µin MIN. MATTE TIN IN SOLDER TAIL AREA OVER 1.27µm/50µin MIN. NICKEL OVERALL.
- 0.76µm/30µin MIN. GOLD IN CONTACT AREA AND 1.88µm/75µin MIN. MATTE TIN IN SOLDER TAIL AREA OVER 1.27µm/50µin MIN. NICKEL OVERALL.
- 2.50µm/100µin MIN. MATTE TIN OVER 1.25µm/50µin MIN. NICKEL OVERALL.

THIS DRAWING CONTAINS INFORMATION THAT IS PROPRIETARY TO MOLEX ELECTRONIC TECHNOLOGIES, LLC AND SHOULD NOT BE USED WITHOUT WRITTEN PERMISSION

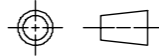
ADDED BTB DIST. EC NO: 621140 DRWN: NMANE02 CHKD: NMANE02 REV APPR: MIRAMAKRISHNA	GENERAL TOLERANCES (UNLESS SPECIFIED)		DIMENSION UNITS		SCALE		 MILLIGRID 2MM PITCH, SMT VERTICAL SHROUDED HEADER PRODUCT CUSTOMER DRAWING SERIES: 87832 MATERIAL NUMBER: SEE TABLE CUSTOMER: GENERAL MARKET DOCUMENT NUMBER: SD-87832-0001 DOC TYPE: PSD DOC PART: 001 SHEET NUMBER: 10 OF 13
			MM	INCH	MM	NTS	
	4 PLACES ±		DRWN BY		DATE		
	3 PLACES ±		GMENARLY		2015/05/22		
	2 PLACES ± 0.2		CHK'D BY		DATE		
1 PLACES ±		CGOH		2015/09/21			
0 PLACES ±		APPR BY		DATE			
		KHLIM		2015/09/22			
ANGULAR TOL = 3.0		DRAWING SIZE		THIRD ANGLE PROJECTION			
DRAFT WHERE APPLICABLE MUST REMAIN WITHIN DIMENSIONS		A3					

40 TO 50 CIRCUITS

CKT SIZE	ASSY P/N WITHOUT CAP IN TUBE	ASSY P/N WITH CAP IN TUBE	ASSY P/N WITH CAP IN T&R	T&R OPTIONS (SEE SHEET 12)	PLATING OPTIONS	FRICTION LOCKS		DUAL SIDE SLOTS	CENTER POLARIZATION	PEGS	DIMENSION							
						DUAL	CENTER				A	B	C	D	E	F	G (COPLAN)	H
40	87832-4060	87832-4062	87832-6962	1	1	YES	N.A	YES	YES	YES	42.65	40.85	38.00	34.00	36.00	41.00	0.15	3.60±0.20
	87832-4020	87832-4022	87832-6922	1	2													
	87832-4021	87832-4023	87832-6923	1	3													
	87832-4070	87832-4072	87832-6972	1	4													
	87832-4012	87832-4016	N.A	N.A	2	YES	N.A	YES	YES	N.A							0.15	3.60±0.20
42	87832-4260	87832-4262	N.A	N.A	1	YES	N.A	YES	YES	YES	44.65	42.85	40.00	36.00	38.00	43.00	0.15	3.60±0.20
	87832-4220	87832-4222	N.A	N.A	2													
	87832-4221	87832-4223	N.A	N.A	3													
	87832-4270	87832-4272	N.A	N.A	4													
44	87832-4460	87832-4462	87832-7162	1	1	YES	N.A	YES	YES	YES	46.65	44.85	42.00	38.00	40.00	45.00	0.15	3.60±0.20
	87832-4420	87832-4422	87832-7122	1	2													
	87832-4421	87832-4423	87832-7123	1	3													
	87832-4470	87832-4472	87832-7172	1	4													
	87832-4413	87832-4417	87832-4415	3	3	YES	N.A	YES	YES	N.A							0.15	3.60±0.20
46	87832-4660	87832-4662	87832-7262	1	1	YES	N.A	YES	YES	YES	48.65	46.85	44.00	40.00	42.00	47.00	0.15	3.60±0.20
	87832-4620	87832-4622	87832-7222	1	2													
	87832-4621	87832-4623	N.A	N.A	3													
	87832-4670	87832-4672	87832-7272	1	4													
48	87832-4860	87832-4862	N.A	N.A	1	YES	N.A	YES	YES	YES	50.65	48.85	46.00	42.00	44.00	49.00	0.15	3.60±0.20
	87832-4820	87832-4822	N.A	N.A	2													
	87832-4821	87832-4823	N.A	N.A	3													
	87832-4870	87832-4872	N.A	N.A	4													
50	87832-5060	87832-5062	87832-7462	1	1	YES	N.A	YES	YES	YES	52.65	50.85	48.00	44.00	46.00	51.00	0.15	3.60±0.20
	87832-5020	87832-5022	87832-7422	1	2													
	87832-5021	87832-5023	87832-7423	1	3													
	87832-5070	87832-5072	87832-7472	1	4													
	87832-5012	87832-5016	N.A	N.A	2	YES	N.A	YES	YES	N.A							0.15	3.60±0.20

PLATING OPTIONS:

- 1 - 0.05-0.13µm/2-5µin GOLD IN CONTACT AREA AND 1.88µm/75µin MIN. MATTE TIN IN SOLDER TAIL AREA OVER 1.27µm/50µin MIN. NICKEL OVERALL.
- 2 - 0.38µm/15µin MIN. GOLD IN CONTACT AREA AND 1.88µm/75µin MIN. MATTE TIN IN SOLDER TAIL AREA OVER 1.27µm/50µin MIN. NICKEL OVERALL.
- 3 - 0.76µm/30µin MIN. GOLD IN CONTACT AREA AND 1.88µm/75µin MIN. MATTE TIN IN SOLDER TAIL AREA OVER 1.27µm/50µin MIN. NICKEL OVERALL.
- 4 - 2.50µm/100µin MIN. MATTE TIN OVER 1.25µm/50µin MIN. NICKEL OVERALL.

THIS DRAWING CONTAINS INFORMATION THAT IS PROPRIETARY TO MOLEX ELECTRONIC TECHNOLOGIES, LLC AND SHOULD NOT BE USED WITHOUT WRITTEN PERMISSION

ADDED BTB DIST. EC NO: 621140 DRWN: NMANE02 CHKD: NMANE02 REV APPR: MRAMAKRISHNA	2019/07/23	GENERAL TOLERANCES (UNLESS SPECIFIED)		DIMENSION UNITS	SCALE	molex®			
	2019/07/23	MM	INCH	MM	NTS	MILLIGRID 2MM PITCH, SMT VERTICAL SHROUDED HEADER PRODUCT CUSTOMER DRAWING SERIES: 87832 MATERIAL NUMBER: SEE TABLE CUSTOMER: GENERAL MARKET DOCUMENT NUMBER: SD-87832-0001 DOC TYPE: PSD DOC PART: 001 SHEET NUMBER: 11 OF 13			
	2019/07/23	4 PLACES ±	±	DRWN BY	DATE				
	2019/07/23	3 PLACES ±	±	GMENARLY	2015/05/22				
	2019/07/23	2 PLACES ± 0.2	±	CHK'D BY	DATE				
2019/07/23	1 PLACES ±	±	CGOH	2015/09/21					
2019/07/23	0 PLACES ±	±	APPR BY	DATE					
2019/07/23	ANGULAR TOL = 3.0			KHLIM	2015/09/22				
2019/07/23	DRAFT WHERE APPLICABLE MUST REMAIN WITHIN DIMENSIONS		DRAWING SIZE	THIRD ANGLE PROJECTION					
2019/07/23	A12	A3							

PACKAGING OPTIONS

OPTION 1

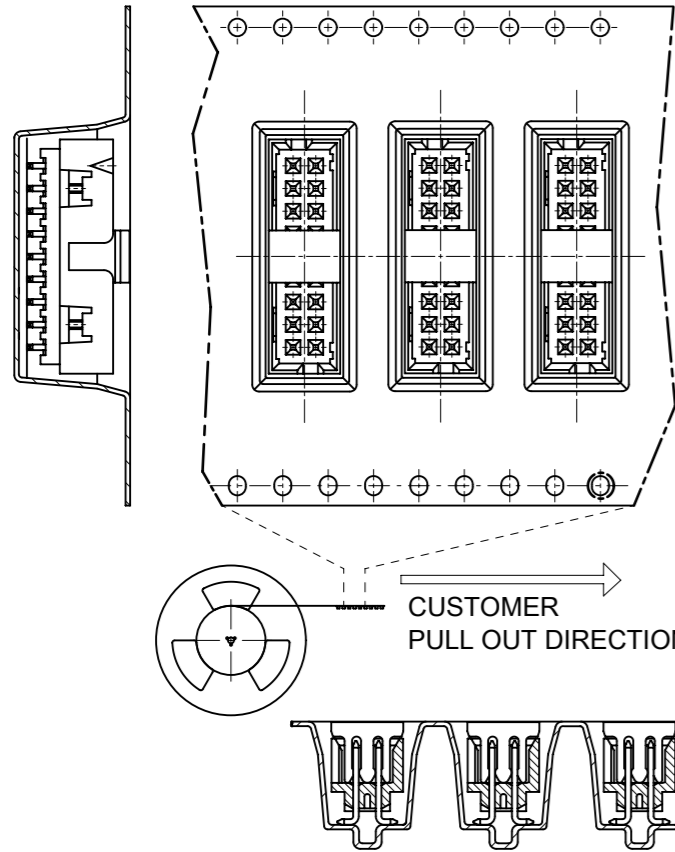

OPTION 2

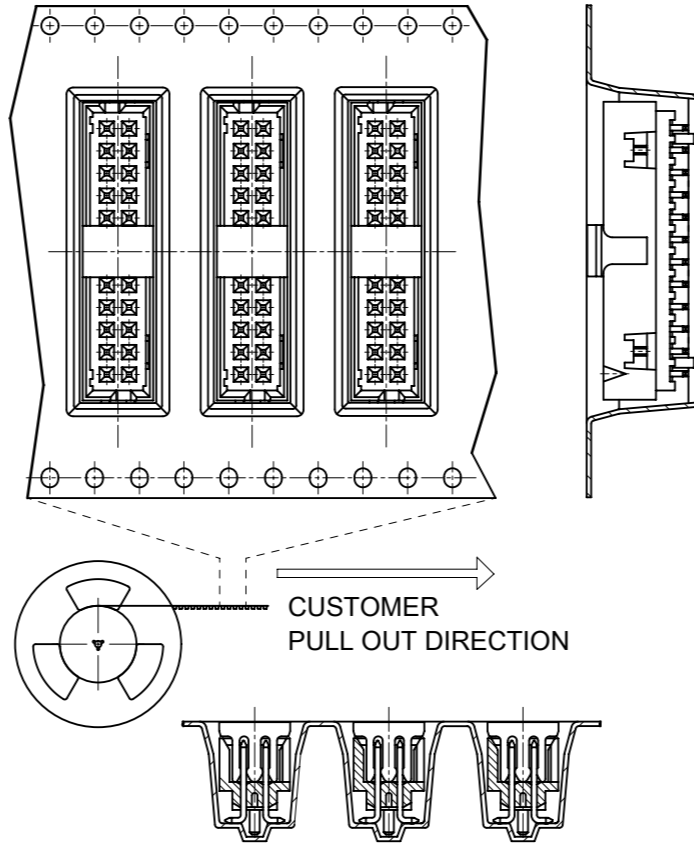

OPTION 3

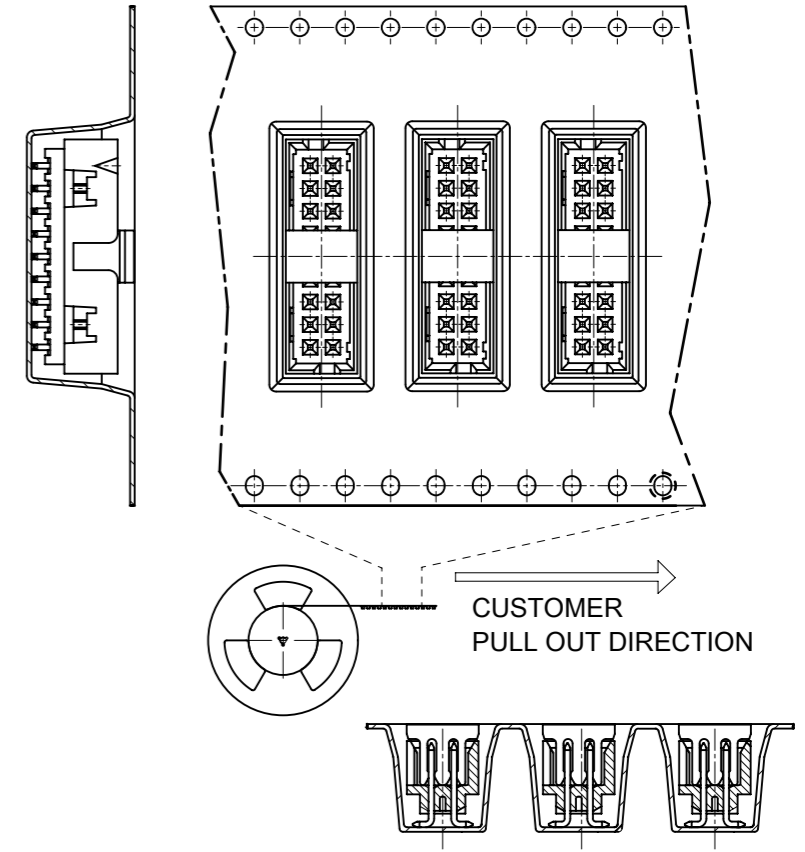

VIEW FOR 1 SIDE PILOT HOLE

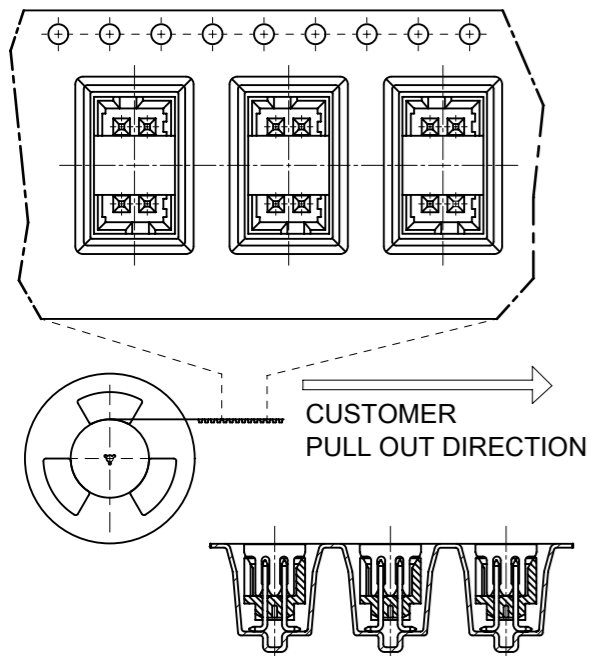

PACKAGING SPECIFICATION TABLE

TAPE AND REEL PACKAGING	PK-87832-300
TUBE STANDARD PACKAGING	PK-87831-001
TUBE NON-STANDARD PACKAGING FOR: 87832-0411 87832-0824 87832-1072 87832-1412	PK-87831-002

EMBOSSED TAPE & REEL POCKET DESCRIPTIONS

OPTIONS	CENTER POLARIZATION OPTIONS		PEG OPTIONS		PILOT HOLE OPTIONS	
	ON THE LEFT	ON THE RIGH	WITH PEG	WITHOUT PEG	2 SIDES	1 SIDE
1	YES	N.A	YES	N.A	CKT 12-50	CKT 4-10
2	N.A	YES	YES	YES	CKT 12-50	CKT 4-10
3	YES	N.A	N.A	YES	CKT 12-50	CKT 4-10

THIS DRAWING CONTAINS INFORMATION THAT IS PROPRIETARY TO MOLEX ELECTRONIC TECHNOLOGIES, LLC AND SHOULD NOT BE USED WITHOUT WRITTEN PERMISSION

EC NO: 621140 DRWN: NMANE02 CHK'D: NMANE02 REV APPR: MRAMAKRISHNA	2019/07/23	2019/07/23	2019/07/23	GENERAL TOLERANCES (UNLESS SPECIFIED)		DIMENSION UNITS MM NTS				
	4 PLACES ± ±		DRWN BY DATE GMENARLY 2015/05/22		MILLIGRID 2MM PITCH, SMT VERTICAL SHROUDED HEADER					
	3 PLACES ± ±		CHK'D BY DATE CGOH 2015/09/21					PRODUCT CUSTOMER DRAWING		
	2 PLACES ± 0.2 ±		APPR BY DATE KHLIM 2015/09/22		SERIES	MATERIAL NUMBER	CUSTOMER			
1 PLACES ± ±		DRAWING SIZE THIRD ANGLE PROJECTION A3		87832	SEE TABLE	GENERAL MARKET				
0 PLACES ± ±		DRAFT WHERE APPLICABLE MUST REMAIN WITHIN DIMENSIONS		DOCUMENT NUMBER		DOC TYPE	DOC PART	SHEET NUMBER		
A12	REV			SD-87832-0001		PSD	001	12 OF 13		

BOARD TO BOARD (BTB) DISTANCE

HEADER	MATES WITH (RECEPTACLE)	BTB DIST.	PICTORIAL VIEW
87832	79107	8.14	
	78787	8.14	
	79108	8.14	
	79109	8.35	
	78788	8.35	

THIS DRAWING CONTAINS INFORMATION THAT IS PROPRIETARY TO MOLEX ELECTRONIC TECHNOLOGIES, LLC AND SHOULD NOT BE USED WITHOUT WRITTEN PERMISSION											
DIMENSION UNITS		SCALE		CURRENT REV DESC: ADDED BTB DIST.							
mm		NTS									
GENERAL TOLERANCES (UNLESS SPECIFIED)				EC NO: 621140		2019/07/23		MILLIGRID			
				DRWN: NMANE02		2019/07/23		2MM PITCH, SMT VERTICAL SHROUDED HEADER			
				CHK'D: NMANE02		2019/07/23		PRODUCT CUSTOMER DRAWING			
				APPR: MRAMAKRISHNA		2019/07/23		DOCUMENT NUMBER			
				INITIAL REVISION:				SD-87832-0001		DOC TYPE	
				DRWN: DRWN BY		XXXX/XX/XX		PSD		DOC PART	
				APPR: APPR BY		XXXX/XX/XX		001		REVISION	
				ANGULAR TOL ± 3.0°				A12			
DRAFT WHERE APPLICABLE MUST REMAIN WITHIN DIMENSIONS				THIRD ANGLE PROJECTION		DRAWING		SERIES		SHEET NUMBER	
						A3-SIZE		87832		13 OF 13	
								MATERIAL NUMBER		CUSTOMER	
								GENERAL MARKET			

Looking for pricing, stock, or lifecycle information?

Click below to explore more details on WIN SOURCE:

 [View 87832-1414 on WIN SOURCE](#)

 [Molex, LLC Information](#)

Optimize Your Supply Chain with WIN SOURCE Solutions

-  Global Sourcing Solution
-  Obsolete Management
-  Cost Control Management
-  Shortage Management
-  Alternative Solution
-  Excess Inventory Management