



**THE DATASHEET OF
THS7374IPWR**





4-Channel SDTV Video Amplifier with 6th-Order Filters and 6-dB Gain

Check for Samples: [THS7374](#)

FEATURES

- 4-SDTV Video Amplifiers for CVBS, S-Video, Y'P'B'P'R 480i/576i, Y'U'V', or G'B'R' (R'G'B')
- Integrated Low-Pass Filters:
 - 6th-Order 9.5-MHz (–3 dB) Butterworth
 - –1 dB Passband Bandwidth at 8.2-MHz
 - 54-dB Attenuation at 27-MHz
- 150-MHz (–3 dB) Filter Bypass Mode
- Versatile Input Biasing
 - DC-Coupled with 300-mV Output Shift
 - AC-Coupled with Sync-Tip Clamp
 - AC-Coupled with Biasing Allowed
- Built-in 6-dB Gain (2 V/V)
- +3-V to +5-V Single-Supply Operation
- Rail-to-Rail Output:
 - Output Swings Within 100 mV from the Rails to Allow AC or DC Output Coupling
 - Supports Driving 2 Lines per Channel
- Low 9.6-mA at 3.3-V Total Quiescent Current
- 0.1- μ A Disabled Supply Current Function
- Low Differential Gain/Phase of 0.15%/0.3°
- Lead-Free and Green TSSOP-14 Package

APPLICATIONS

- Low-Cost SCART Systems
- Set Top Box Output Video Buffering
- Surveillance Systems

DESCRIPTION

Fabricated using the revolutionary complementary Silicon-Germanium (SiGe) BiCom3X process, the THS7374 is a low-power, single-supply 3 V to 5 V four-channel integrated video buffer. It incorporates a sixth-order Butterworth filter (able to be bypassed) which is useful as a digital-to-analog converter (DAC) reconstruction filter or an analog-to-digital converter (ADC) anti-aliasing filter. The 9.5-MHz filter is a perfect choice for SDTV video that includes composite (CVBS), s-video, Y'U'V', G'B'R' (R'G'B'), and Y'P'B'P'R 480i/576i.

As part of the THS7374 flexibility, the input can be configured for either ac or dc-coupled inputs. The 300-mV output level shift allows for a full sync dynamic range at the output with 0-V input. The ac-coupled modes include a transparent sync-tip clamp option for CVBS, Y', and G'B'R' signals with sync. AC-coupled biasing for C'/P'B'/P'R channels can easily be achieved by adding an external resistor.

The THS7374 is the perfect choice for all video buffer applications. Its rail-to-rail output stage with 6-dB gain allows for both ac and dc line driving. The ability to drive two lines per channel, or 75- Ω loads, allows for maximum flexibility as a video line driver. The 9.6-mA total quiescent current at 3.3 V and 0.1- μ A disabled current makes it an excellent choice for portable or other power-sensitive applications.

The THS7374 is available in a TSSOP-14 package that is lead-free and green (RoHS) compliant.

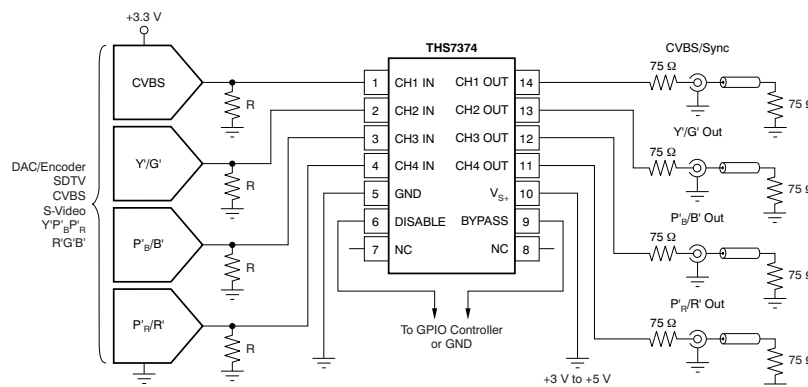

Figure 1. 3.3-V Single-Supply, DC-Input/DC-Output Coupled Video Line Driver



Please be aware that an important notice concerning availability, standard warranty, and use in critical applications of Texas Instruments semiconductor products and disclaimers thereto appears at the end of this data sheet.

All trademarks are the property of their respective owners.



This integrated circuit can be damaged by ESD. Texas Instruments recommends that all integrated circuits be handled with appropriate precautions. Failure to observe proper handling and installation procedures can cause damage.

ESD damage can range from subtle performance degradation to complete device failure. Precision integrated circuits may be more susceptible to damage because very small parametric changes could cause the device not to meet its published specifications.

PACKAGE/ORDERING INFORMATION⁽¹⁾⁽²⁾

| PRODUCT | PACKAGE-LEAD | TRANSPORT MEDIA, QUANTITY | ECO STATUS ⁽²⁾ |
|-------------|--------------|---------------------------|---------------------------|
| THS7374IPW | TSSOP-14 | Rails, 90 | Pb-Free, Green |
| THS7374IPWR | | Tape and Reel, 2000 | |

- (1) For the most current package and ordering information see the Package Option Addendum at the end of this document, or see the TI web site at www.ti.com.
- (2) These packages conform to Lead (Pb)-free and green manufacturing specifications. Additional details including specific material content can be accessed at www.ti.com/leadfree.
 GREEN: TI defines Green to mean Lead (Pb)-Free and in addition, uses less package materials that do not contain halogens, including bromine (Br), or antimony (Sb) above 0.1% of total product weight. N/A: Not yet available Lead (Pb)-Free; for estimated conversion dates, go to www.ti.com/leadfree. Pb-FREE: TI defines Lead (Pb)-Free to mean RoHS compatible, including a lead concentration that does not exceed 0.1% of total product weight, and, if designed to be soldered, suitable for use in specified lead-free soldering processes.

ABSOLUTE MAXIMUM RATINGS⁽¹⁾

Over operating free-air temperature range unless otherwise noted.

| | | THS7374 | UNIT |
|--|----------------------------|---|------|
| Supply voltage, V_{S+} to GND | | 5.5 | V |
| Input voltage, V_I | | -0.4 to V_S | V |
| Output current, I_O | | 100 | mA |
| Continuous power dissipation | | See Dissipation Ratings Table | |
| Maximum junction temperature, any condition ⁽²⁾ T_J | | +150 | °C |
| Maximum junction temperature, continuous operation, long-term reliability ⁽³⁾ , T_J | | +125 | °C |
| Storage temperature range, T_{STG} | | -65 to +150 | °C |
| ESD ratings | Human body model (HBM) | 2000 | V |
| | Charged device model (CDM) | 1000 | V |
| | Machine model (MM) | 200 | V |

- (1) Stresses above these ratings may cause permanent damage. Exposure to absolute maximum conditions for extended periods may degrade device reliability. These are stress ratings only, and functional operation of the device at these or any other conditions beyond those specified is not implied.
- (2) The absolute maximum junction temperature under any condition is limited by the constraints of the silicon process.
- (3) The absolute maximum junction temperature for continuous operation is limited by the package constraints. Operation above this temperature may result in reduced reliability and/or lifetime of the device.

DISSIPATION RATINGS

| PACKAGE | θ_{JC} (°C/W) | θ_{JA} (°C/W) | AT $T_A \leq +25^\circ\text{C}$ POWER RATING | AT $T_A = +85^\circ\text{C}$ POWER RATING |
|---------------|-------------------------|-------------------------|---|--|
| TSSOP-14 (PW) | 35 | 115 | 870 mW | 348 mW |

RECOMMENDED OPERATING CONDITIONS

| | MIN | NOM | MAX | UNIT |
|----------------------------|-----|-----|-----|------|
| Supply voltage, V_{S+} | 3 | | 5 | V |
| Ambient temperature, T_A | -40 | | +85 | °C |

ELECTRICAL CHARACTERISTICS $V_{S+} = +3.3\text{ V}$
 $R_L = 150\ \Omega$ to GND and dc-coupled input and output, Filter Mode, unless otherwise noted.

| PARAMETER | TEST CONDITIONS | THS7374 | | | | MIN/ TYP/ MAX | UNITS |
|--|--|-----------|------------------|-----------------|-------------------|---------------------|------------|
| | | TYP | OVER TEMPERATURE | | | | |
| | | +25°C | +25°C | 0°C to +70°C | –40°C to +85°C | | |
| AC PERFORMANCE | | | | | | | |
| Small-signal bandwidth (–3 dB) | $V_O = 0.2\ V_{PP}^{(1)}$ | 9.5 | 7.6/11.4 | 7.4/11.6 | 7.3/11.7 | Min/ Max | MHz |
| Large-signal bandwidth (–3 dB) | $V_O = 2\ V_{PP}^{(1)}$ | 9.5 | 7.6/11.4 | 7.4/11.6 | 7.3/11.7 | Min/ Max | MHz |
| –1 dB passband bandwidth | | 8.2 | | | | Typ | MHz |
| Bypass mode bandwidth (–3 dB) | $V_O = 0.2\ V_{PP}$ | 150 | | | | Typ | MHz |
| Slew rate | Bypass mode | 130 | | | | Typ | V/ μ s |
| Attenuation with respect to 500 kHz | $f = 6.75\ \text{MHz}^{(2)}$ | 0.25 | –0.9/1.1 | –1/1.4 | –1.1/1.6 | Min/ Max | dB |
| | $f = 27\ \text{MHz}^{(2)}$ | 54 | 42 | 40 | 39 | Min | dB |
| Group delay | $f = 100\ \text{kHz}$ | 70 | | | | Typ | ns |
| Group delay variation with respect to 100 kHz | $f = 5.1\ \text{MHz}$ | 8.5 | | | | Typ | ns |
| Channel-to-channel delay | | 0.3 | | | | Typ | ns |
| Differential gain (NTSC/PAL) | NTSC/PAL | 0.15/0.25 | | | | TYP | % |
| Differential phase (NTSC/PAL) | NTSC/PAL | 0.3/0.35 | | | | Typ | ° |
| Total harmonic distortion | $f = 1\ \text{MHz}; V_O = 2\ V_{PP}$ | –65 | | | | Typ | dB |
| Signal-to-noise ratio | 100 kHz to 6 MHz: non-weighted/ unified weighting | 70/78 | | | | Typ | dB |
| Channel-to-channel crosstalk | $f = 1\ \text{MHz}$ | –55 | | | | Typ | dB |
| AC gain—all channels | | 6 | 5.7/6.3 | 5.65/6.35 | 5.65/6.35 | Min/ Max | dB |
| Output impedance | $f = 5\ \text{MHz};$ filter mode | 0.7 | | | | Typ | Ω |
| DC PERFORMANCE | | | | | | | |
| Biased output voltage/level shift | $V_{IN} = 0\ \text{V}$ | 300 | 210/390 | 200/400 | 190/410 | Min/ Max | mV |
| Input voltage range | DC input, limited by output | –0.1/1.46 | | | | Typ | V |
| Sync tip clamp charge current | $V_{IN} = -0.1\ \text{V}$ | 200 | 140 | 130 | 120 | Min | μ A |
| Input resistance | | 800 | | | | Typ | k Ω |
| Input capacitance | | 2 | | | | Typ | pF |
| OUTPUT CHARACTERISTICS | | | | | | | |
| High output voltage swing | $R_L = 150\ \Omega$ to +1.65 V | 3.15 | | | | Typ | V |
| | $R_L = 150\ \Omega$ to GND | 3.1 | 2.85 | 2.75 | 2.75 | Min | V |
| | $R_L = 75\ \Omega$ to +1.65 V | 3.1 | | | | Typ | V |
| | $R_L = 75\ \Omega$ to GND | 3 | | | | Typ | V |
| Low output voltage swing | $R_L = 150\ \Omega$ to +1.65 V ($V_{IN} = -0.2\ \text{V}$) | 0.05 | | | | Typ | V |
| | $R_L = 150\ \Omega$ to GND ($V_{IN} = -0.2\ \text{V}$) | 0.03 | 0.12 | 0.16 | 0.17 | Max | V |
| | $R_L = 75\ \Omega$ to +1.65 V ($V_{IN} = -0.2\ \text{V}$) | 0.1 | | | | Typ | V |
| | $R_L = 75\ \Omega$ to GND ($V_{IN} = -0.2\ \text{V}$) | 0.05 | | | | Typ | V |
| Output current (sourcing) | $R_L = 10\ \Omega$ to +1.65 V | 80 | | | | Typ | mA |
| Output current (sinking) | $R_L = 10\ \Omega$ to +1.65 V | 70 | | | | Typ | mA |

(1) The min/max values listed for this specification are ensured by design and characterization only.

(2) 3.3-V supply filter specifications are ensured by 100% testing at 5-V supply along with design and characterization only.

ELECTRICAL CHARACTERISTICS $V_{S+} = +3.3\text{ V}$ (continued)
 $R_L = 150\ \Omega$ to GND and dc-coupled input and output, Filter Mode, unless otherwise noted.

| PARAMETER | TEST CONDITIONS | THS7374 | | | | MIN/ TYP/ MAX | UNITS |
|--|--|---------|------------------|-----------------|-------------------|---------------------|------------------|
| | | TYP | OVER TEMPERATURE | | | | |
| | | +25°C | +25°C | 0°C to +70°C | -40°C to +85°C | | |
| POWER SUPPLY | | | | | | | |
| Maximum operating voltage | V_{S+} to GND | 3.3 | 5.5 | 5.5 | 5.5 | Max | V |
| Minimum operating voltage | V_{S+} to GND ⁽³⁾ | 3.3 | 2.85 | 2.85 | 2.85 | Min | V |
| Maximum total quiescent current | $V_{IN} = 0\text{ V}; V_{S+} = 3.3\text{ V}$ | 9.6 | 12 | 13 | 14 | Max | mA |
| Minimum total quiescent current | $V_{IN} = 0\text{ V}; V_{S+} = 3.3\text{ V}$ | 9.6 | 8 | 7 | 6.5 | Min | mA |
| Disabled total quiescent current | Disable pin = 2 V | 0.1 | 10 | 10 | 10 | Max | μA |
| Power-supply rejection (+PSRR) | | 52 | | | | Typ | dB |
| LOGIC CHARACTERISTICS⁽⁴⁾ | | | | | | | |
| V_{IH} | Disabled or bypass engaged | 1.8 | 2 | 2 | 2 | Min | V |
| V_{IL} | Enabled or bypass disengaged | 0.7 | 0.65 | 0.6 | 0.6 | Max | V |
| I_{IH} | | 0.2 | | | | Typ | μA |
| I_{IL} | | 0.2 | | | | Typ | μA |
| Disable time | | 100 | | | | Typ | ns |
| Enable time | | 100 | | | | Typ | ns |
| Bypass/filter switch time | | 5 | | | | Typ | ns |
| Disabled output impedance | Disable pin = 2 V | 20 3 | | | | Typ | k Ω pF |

(3) The min/max values listed for this specification are ensured by design and characterization only.

(4) The logic input pins should not be left floating. They must be connected to logic low (or GND) or logic high (or V_{S+}).

ELECTRICAL CHARACTERISTICS $V_{S+} = +5\text{ V}$
 $R_L = 150\ \Omega$ to GND and dc-coupled input and output, Giler Mode, unless otherwise noted.

| PARAMETER | TEST CONDITIONS | THS7374 | | | | MIN/ TYP/ MAX | UNITS |
|--|--|----------|------------------|-----------------|-------------------|---------------------|------------|
| | | TYP | OVER TEMPERATURE | | | | |
| | | +25°C | +25°C | 0°C to +70°C | –40°C to +85°C | | |
| AC PERFORMANCE | | | | | | | |
| Small-signal bandwidth (–3 dB) | $V_O = 0.2\ V_{PP}^{(1)}$ | 9.5 | 7.6/11.4 | 7.4/11.6 | 7.3/11.7 | Min/ Max | MHz |
| Large-signal bandwidth (–3 dB) | $V_O = 2\ V_{PP}^{(1)}$ | 9.5 | 7.6/11.4 | 7.4/11.6 | 7.3/11.7 | Min/ Max | MHz |
| –1 dB passband bandwidth | | 8.2 | | | | Typ | MHz |
| Bypass mode bandwidth (–3 dB) | $V_O = 0.2\ V_{PP}$ | 150 | | | | Typ | MHz |
| Slew rate | Bypass mode | 130 | | | | Typ | V/ μ s |
| Attenuation with respect to 500 kHz | $f = 6.75\ \text{MHz}$ | 0.25 | –0.9/1.1 | –1/1.4 | –1.1/1.6 | Min/ Max | dB |
| | $f = 27\ \text{MHz}$ | 54 | 42 | 40 | 39 | Min | dB |
| Group delay | $f = 100\ \text{kHz}$ | 70 | | | | Typ | ns |
| Group delay variation with respect to 100 kHz | $f = 5.1\ \text{MHz}$ | 8.5 | | | | Typ | ns |
| Channel-to-channel delay | | 0.3 | | | | Typ | ns |
| Differential gain (NTSC/PAL) | NTSC/PAL | 0.1/0.25 | | | | TYP | % |
| Differential phase (NTSC/PAL) | NTSC/PAL | 0.3/0.4 | | | | Typ | ° |
| Total harmonic distortion | $f = 1\ \text{MHz}; V_O = 2\ V_{PP}$ | –69 | | | | Typ | dB |
| Signal-to-noise ratio | 100 kHz to 6 MHz: non-weighted/ unified weighting | 70/78 | | | | Typ | dB |
| Channel-to-channel crosstalk | $f = 1\ \text{MHz}$ | –66 | | | | Typ | dB |
| AC gain—all channels | | 6 | 5.7/6.3 | 5.65/6.35 | 5.65/6.35 | Min/ Max | dB |
| Output impedance | $f = 5\ \text{MHz};$ filter mode | 0.7 | | | | Typ | Ω |
| DC PERFORMANCE | | | | | | | |
| Biased output voltage/level shift | $V_{IN} = 0\ \text{V}$ | 310 | 210/390 | 200/400 | 190/410 | Min/ Max | mV |
| Input voltage range | Limited by output | –0.1/2.3 | | | | Typ | V |
| Sync tip clamp charge current | $V_{IN} = -0.1\ \text{V}$ | 200 | 140 | 130 | 120 | Min | μ A |
| Input resistance | | 800 | | | | Typ | k Ω |
| Input capacitance | | 2 | | | | Typ | pF |
| OUTPUT CHARACTERISTICS | | | | | | | |
| High output voltage swing | $R_L = 150\ \Omega$ to +2.5V | 4.85 | | | | Typ | V |
| | $R_L = 150\ \Omega$ to GND | 4.75 | 4.4 | 4.3 | 4.3 | Min | V |
| | $R_L = 75\ \Omega$ to +2.5V | 4.7 | | | | Typ | V |
| | $R_L = 75\ \Omega$ to GND | 4.5 | | | | Typ | V |
| Low output voltage swing | $R_L = 150\ \Omega$ to +2.5V ($V_{IN} = -0.2\ \text{V}$) | 0.05 | | | | Typ | V |
| | $R_L = 150\ \Omega$ to GND ($V_{IN} = -0.2\ \text{V}$) | 0.03 | 0.12 | 0.16 | 0.17 | Max | V |
| | $R_L = 75\ \Omega$ to +2.5 V ($V_{IN} = -0.2\ \text{V}$) | 0.1 | | | | Typ | V |
| | $R_L = 75\ \Omega$ to GND ($V_{IN} = -0.2\ \text{V}$) | 0.05 | | | | Typ | V |
| Output current (sourcing) | $R_L = 10\ \Omega$ to +2.5 V | 90 | | | | Typ | mA |
| Output current (sinking) | $R_L = 10\ \Omega$ to +2.5 V | 85 | | | | Typ | mA |

(1) The min/max values listed for this specification are ensured by design and characterization only.

ELECTRICAL CHARACTERISTICS $V_{S+} = +5\text{ V}$ (continued)
 $R_L = 150\ \Omega$ to GND and dc-coupled input and output, Giler Mode, unless otherwise noted.

| PARAMETER | TEST CONDITIONS | THS7374 | | | | MIN/ TYP/ MAX | UNITS |
|--|---|---------|------------------|-----------------|-------------------|---------------------|------------------|
| | | TYP | OVER TEMPERATURE | | | | |
| | | +25°C | +25°C | 0°C to +70°C | -40°C to +85°C | | |
| POWER SUPPLY | | | | | | | |
| Maximum operating voltage | V_{S+} to GND | 5 | 5.5 | 5.5 | 5.5 | Max | V |
| Minimum operating voltage | V_{S+} to GND ⁽²⁾ | 5 | 2.85 | 2.85 | 2.85 | Min | V |
| Maximum total quiescent current | $V_{IN} = 0\text{ V}$, $V_{S+} = 5\text{ V}$ | 10 | 12.5 | 13.5 | 14.5 | Max | mA |
| Minimum total quiescent current | $V_{IN} = 0\text{ V}$, $V_{S+} = 5\text{ V}$ | 10 | 8 | 7.5 | 7 | Min | mA |
| Disabled total quiescent current | Disable pin = 3 V | 1 | 10 | 10 | 10 | Max | μA |
| Power-supply rejection (+PSRR) | | 52 | | | | Typ | dB |
| DISABLE CHARACTERISTICS⁽³⁾ | | | | | | | |
| V_{IH} | Disabled/bypass engaged ⁽⁴⁾ | 2.1 | 2.2 | 2.2 | 2.2 | Min | V |
| V_{IL} | Enabled/bypass disengaged | 0.8 | 0.8 | 0.8 | 0.8 | Max | V |
| I_{IH} | | 0.2 | | | | Typ | μA |
| I_{IL} | | 0.2 | | | | Typ | μA |
| Disable time | | 80 | | | | Typ | ns |
| Enable time | | 80 | | | | Typ | ns |
| Bypass/filter switch time | | 5 | | | | Typ | ns |
| Disabled output impedance | Disable pin = 3 V | 20 3 | | | | Typ | k Ω pF |

(2) The min/max values listed for this specification are ensured by design and characterization only.

(3) The logic input pins should not be left floating. They must be connected to logic low (or GND) or logic high (or V_{S+}).

(4) Defined as applied logic voltage to achieve total quiescent current of less than 100 μA .

PIN CONFIGURATION

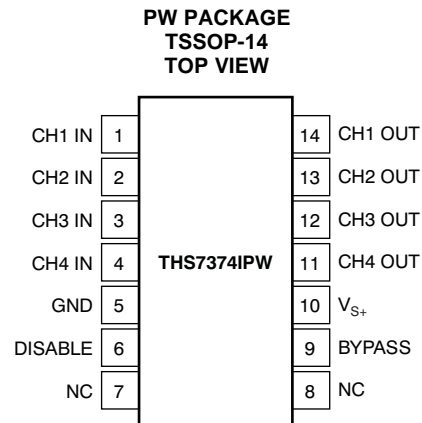
Table 1. TERMINAL FUNCTIONS

| TERMINAL | | I/O | DESCRIPTION |
|-----------------|------|-----|--|
| NAME | NO. | | |
| CH1 IN | 1 | I | Video input; channel 1 |
| CH2 IN | 2 | I | Video input; channel 2 |
| CH3 IN | 3 | I | Video input; channel 3 |
| CH4 IN | 4 | I | Video input; channel 4 |
| GND | 5 | I | Ground pin for all internal circuitry |
| DISABLE | 6 | I | Disable pin. Logic high disables the part; logic low enables the part. This pin must not be left floating. It must be connected to a defined logic state (or GND or V _{S+}). |
| NC | 7, 8 | — | No internal connection |
| BYPASS | 9 | I | Internal filter bypass. Logic high bypasses the internal low-pass filter; logic low uses the internal filters. This pin must not be left floating. It must be connected to a defined logic state (or GND or V _{S+}). |
| V _{S+} | 10 | I | Positive power-supply pin; connect to +3 V to +5 V |
| CH4 OUT | 11 | O | Video output; channel 4 |
| CH3 OUT | 12 | O | Video output; channel 3 |
| CH2 OUT | 13 | O | Video output; channel 2 |
| CH1 OUT | 14 | O | Video output; channel 1 |

FUNCTIONAL BLOCK DIAGRAM

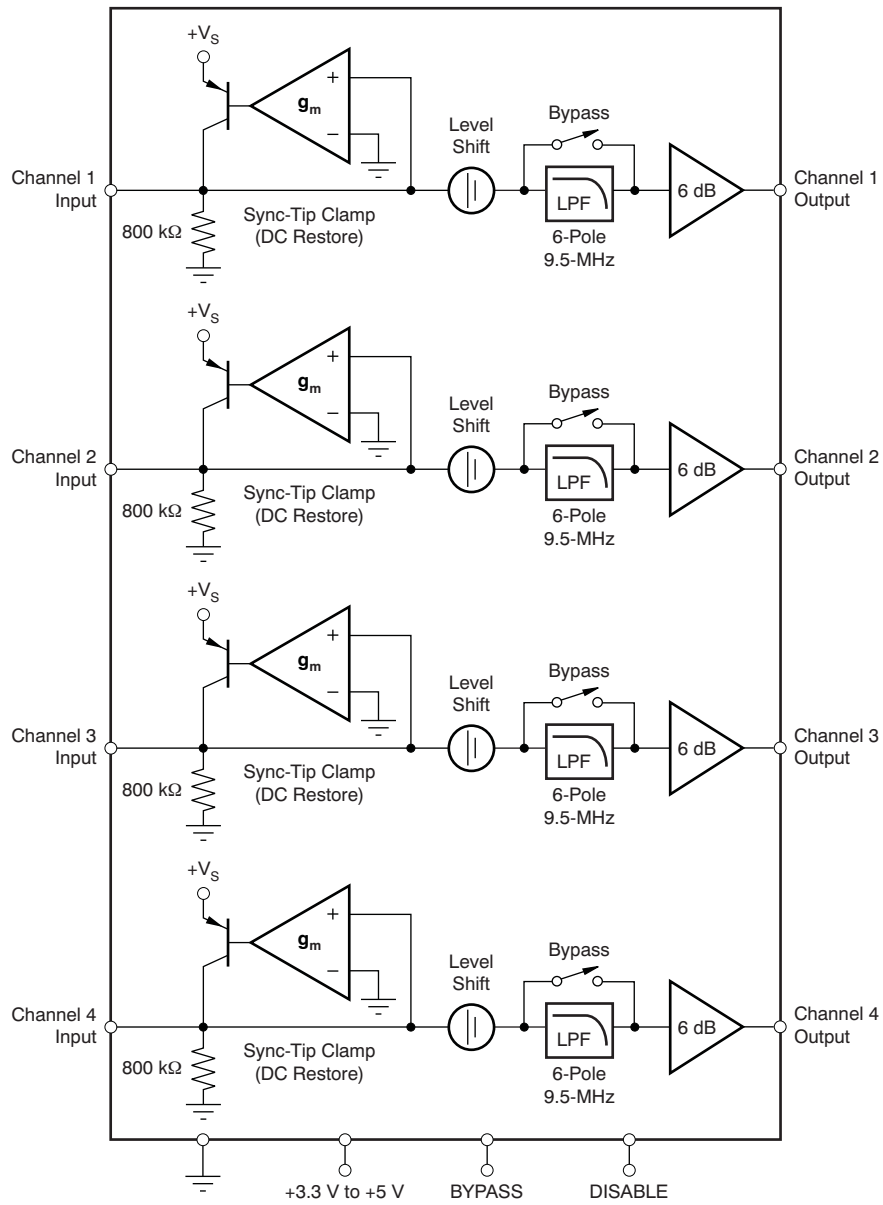

TYPICAL CHARACTERISTICS: GENERAL

$R_L = 150 \Omega$ to GND and dc-coupled input and output, unless otherwise noted.

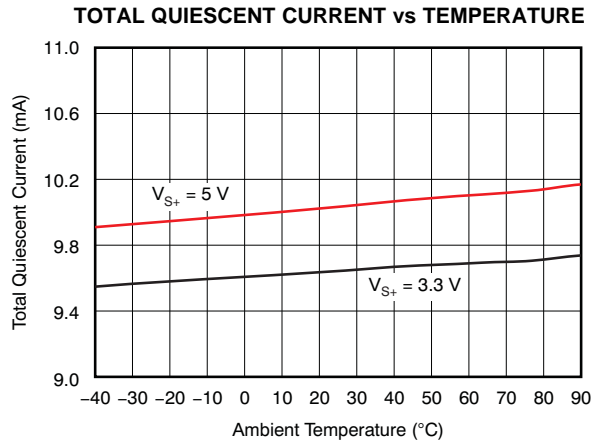

Figure 2.

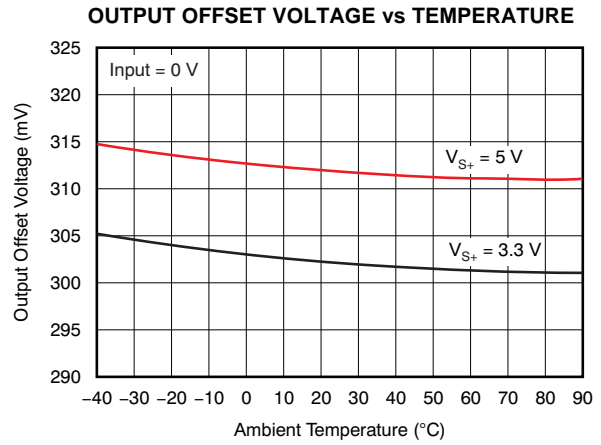

Figure 3.

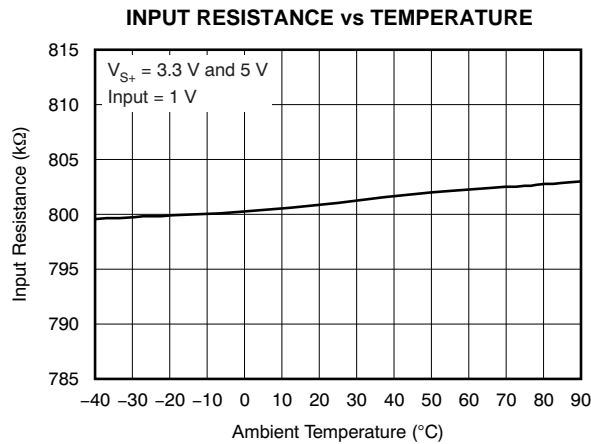

Figure 4.

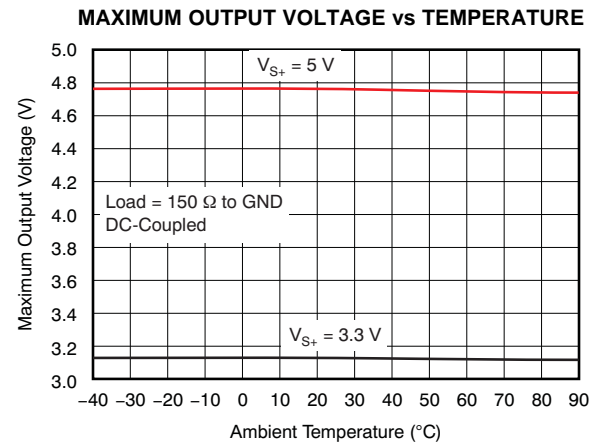

Figure 5.

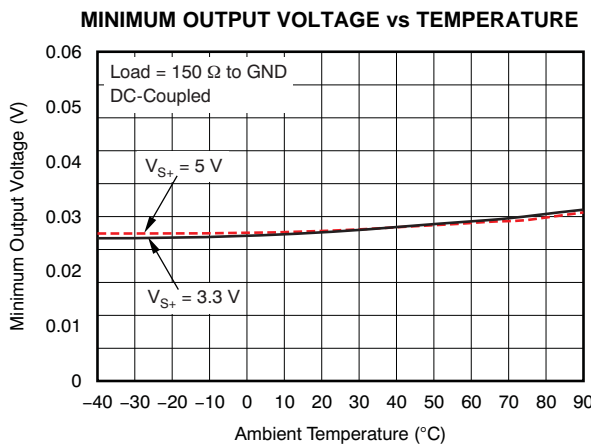

Figure 6.

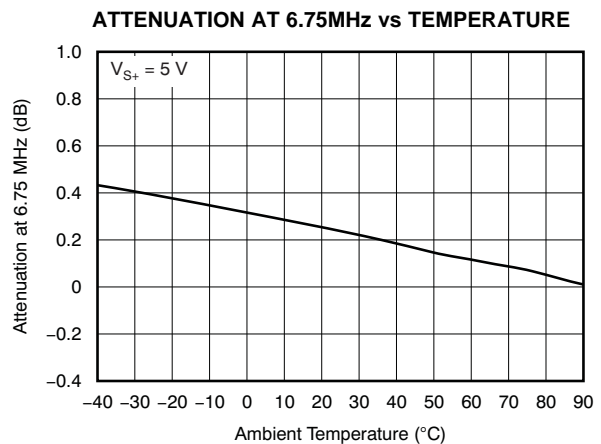

Figure 7.

TYPICAL CHARACTERISTICS: GENERAL (continued)

$R_L = 150 \Omega$ to GND and dc-coupled input and output, unless otherwise noted.

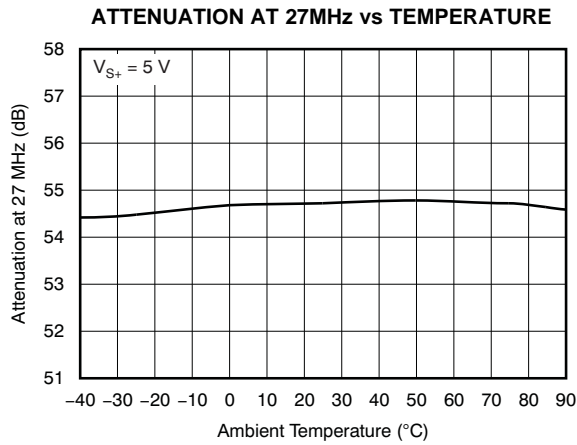

Figure 8.

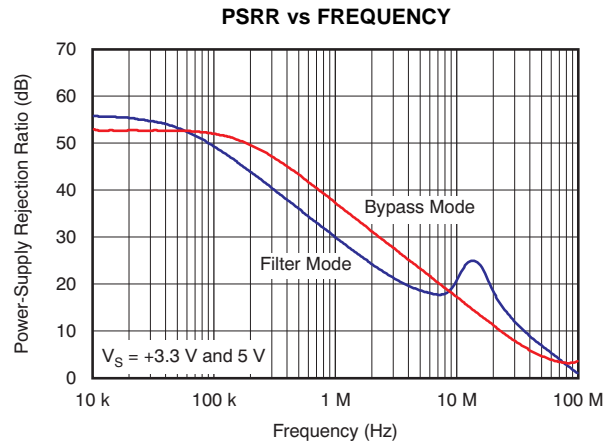

Figure 9.

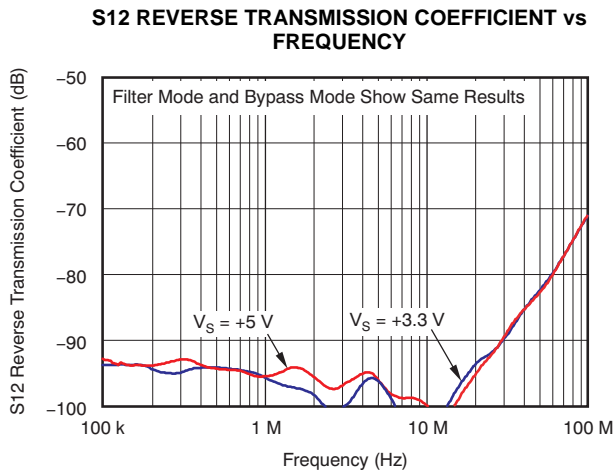

Figure 10.

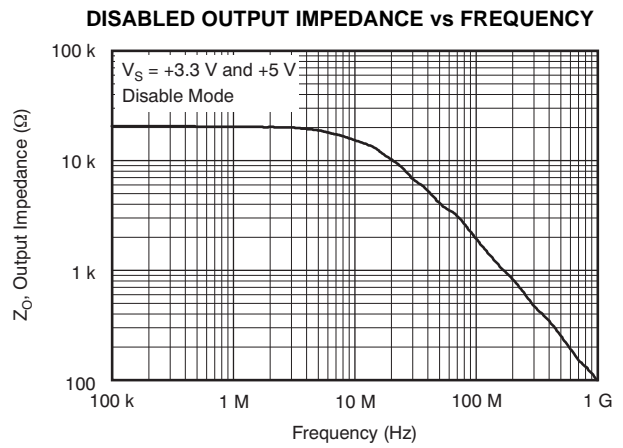

Figure 11.

TYPICAL CHARACTERISTICS: $V_{S+} = 3.3\text{ V}$

$R_L = 150\ \Omega$ to GND and dc-coupled input and output, unless otherwise noted.

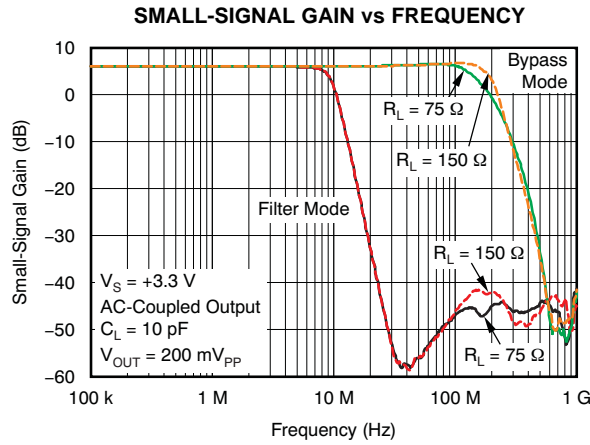

Figure 12.

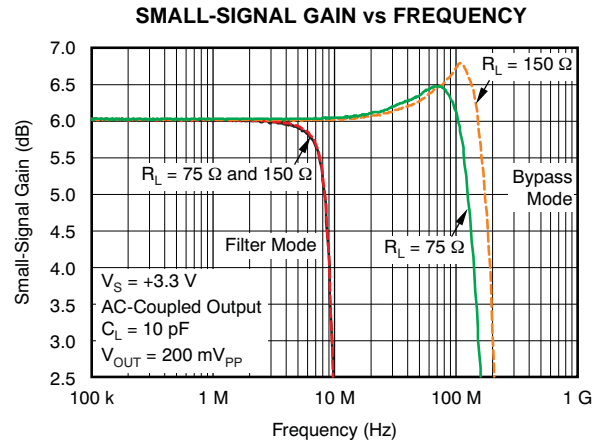

Figure 13.

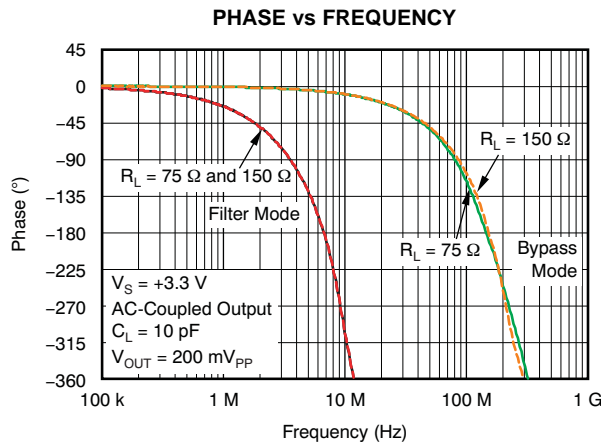

Figure 14.

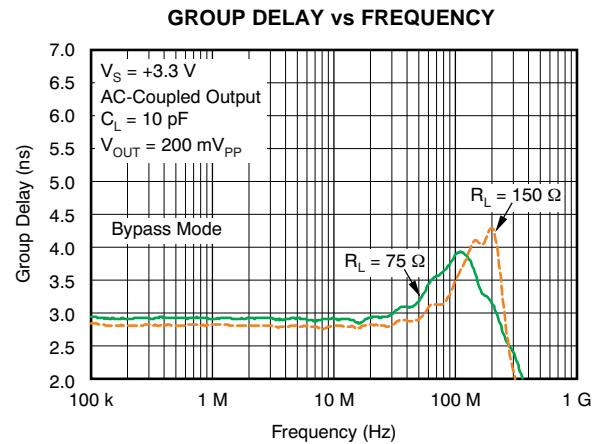

Figure 15.

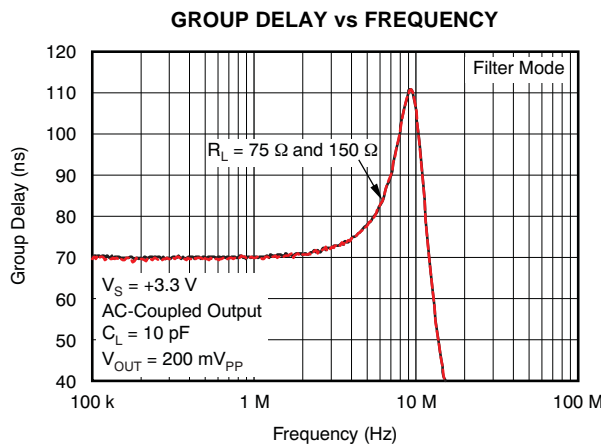

Figure 16.

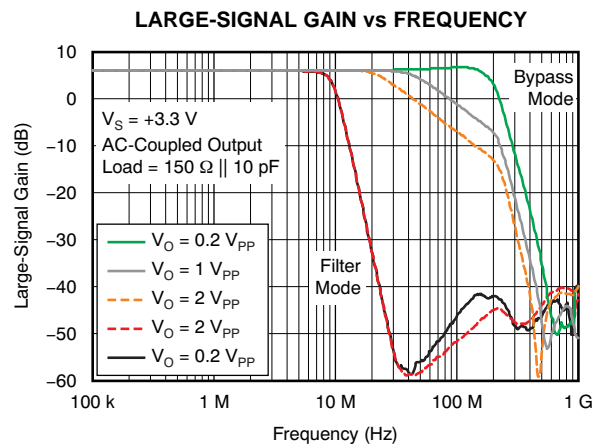

Figure 17.

TYPICAL CHARACTERISTICS: $V_{S+} = 3.3\text{ V}$ (continued)

$R_L = 150\ \Omega$ to GND and dc-coupled input and output, unless otherwise noted.

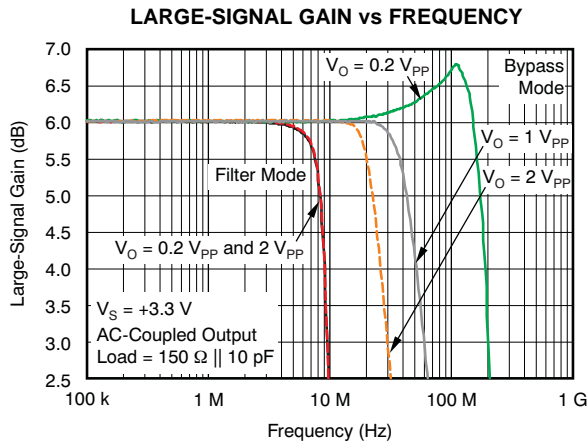

Figure 18.

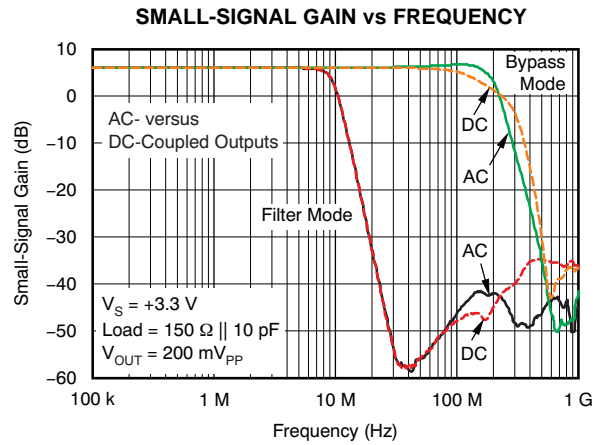

Figure 19.

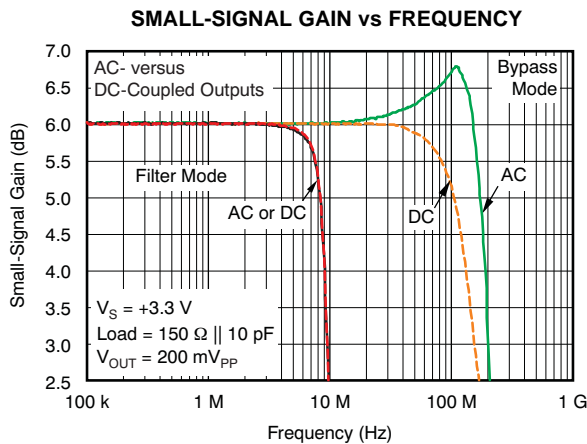

Figure 20.

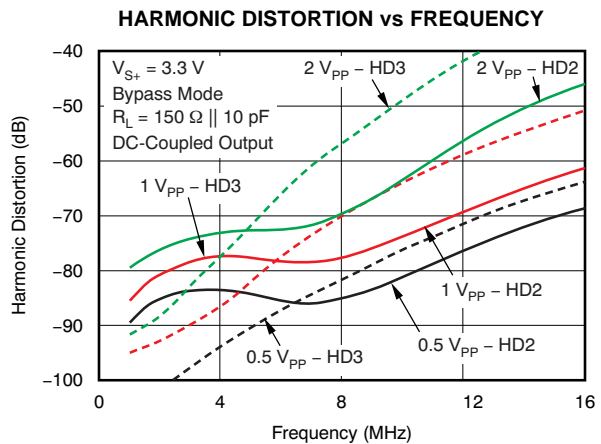

Figure 21.

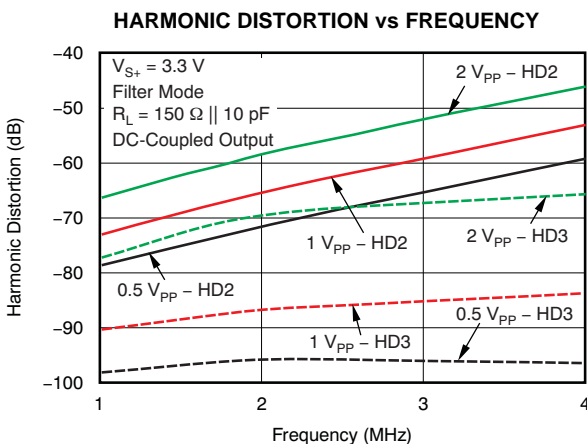

Figure 22.

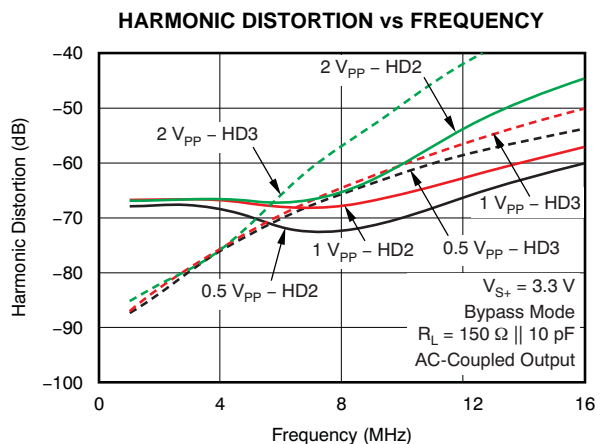

Figure 23.

TYPICAL CHARACTERISTICS: $V_{S+} = 3.3\text{ V}$ (continued)

$R_L = 150\ \Omega$ to GND and dc-coupled input and output, unless otherwise noted.

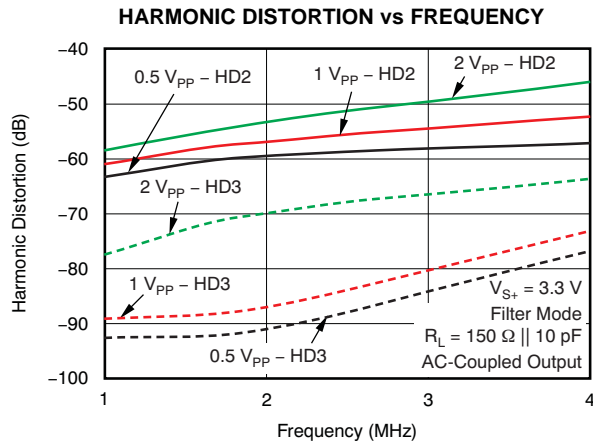

Figure 24.

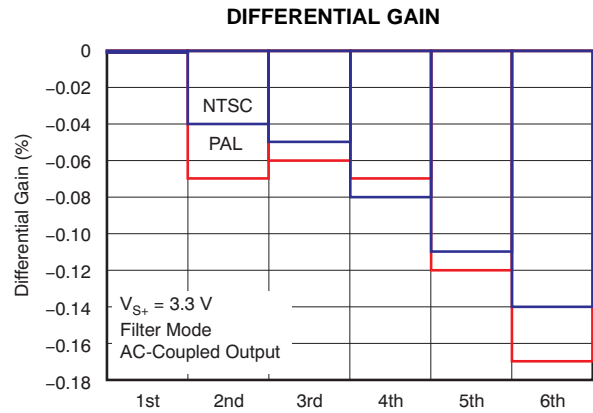

Figure 25.

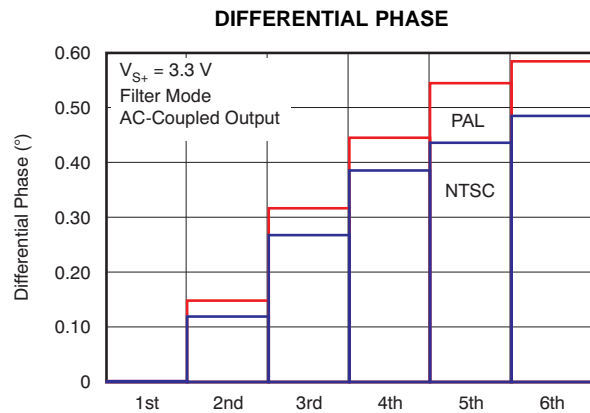

Figure 26.

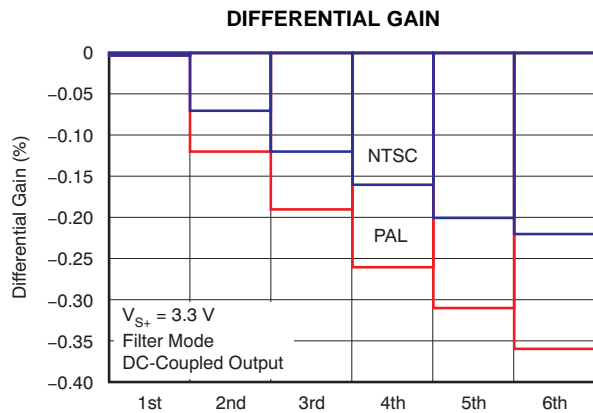

Figure 27.

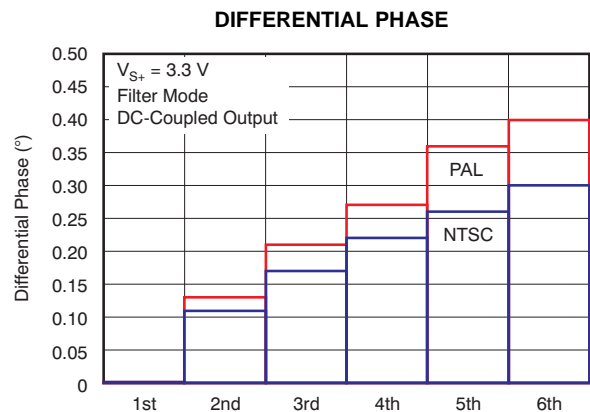

Figure 28.

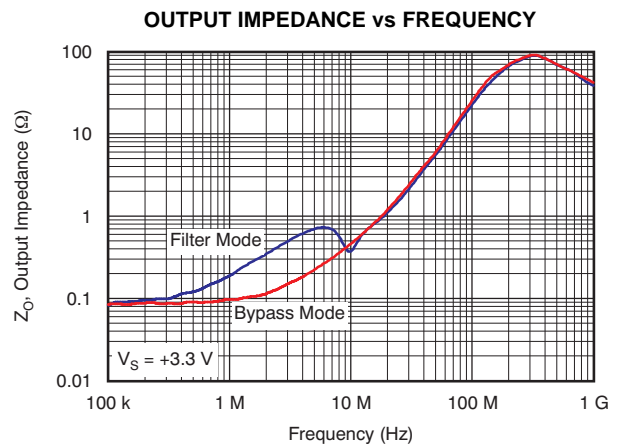

Figure 29.

TYPICAL CHARACTERISTICS: $V_{S+} = 3.3\text{ V}$ (continued)

$R_L = 150\ \Omega$ to GND and dc-coupled input and output, unless otherwise noted.

S22 OUTPUT REFLECTION COEFFICIENT vs FREQUENCY

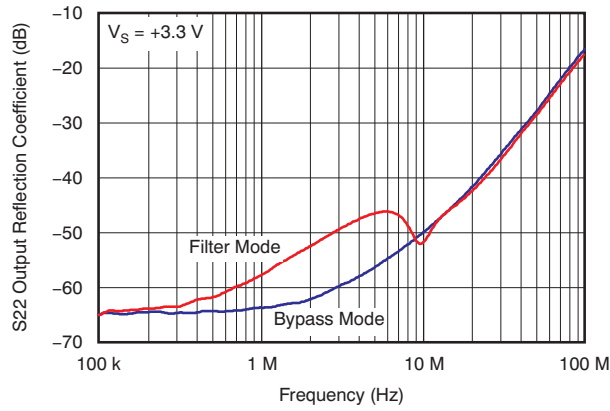

Figure 30.

SMALL-SIGNAL GAIN vs FREQUENCY

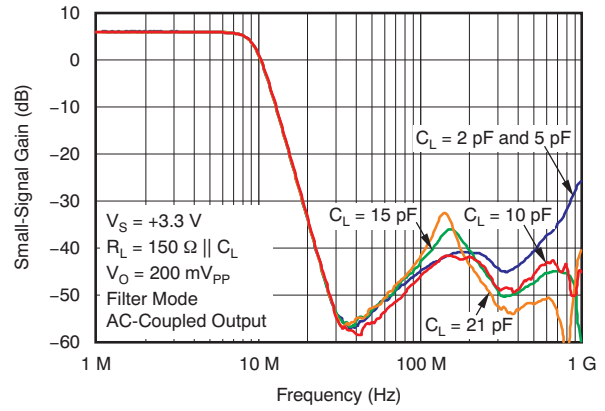

Figure 31.

SMALL-SIGNAL GAIN vs FREQUENCY

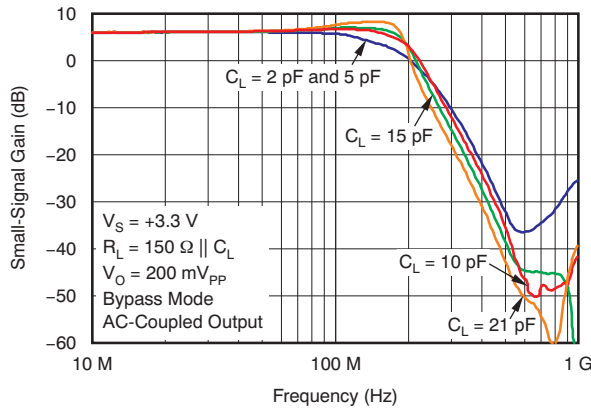

Figure 32.

SMALL-SIGNAL GAIN vs FREQUENCY

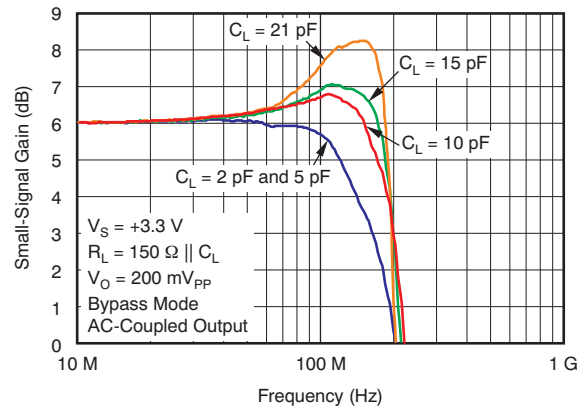

Figure 33.

TYPICAL CHARACTERISTICS: $V_{S+} = 5\text{ V}$

$R_L = 150\ \Omega$ to GND and dc-coupled input and output, unless otherwise noted.

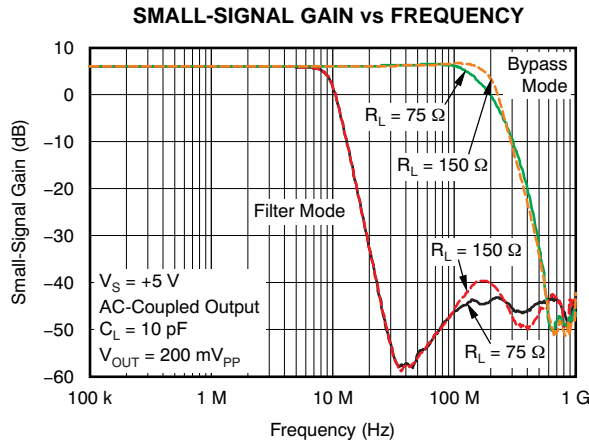

Figure 34.

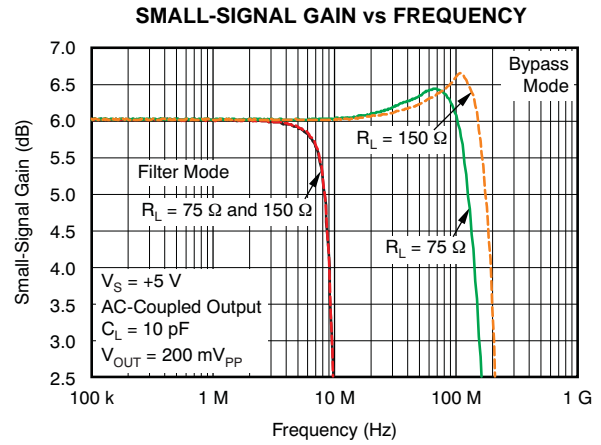

Figure 35.

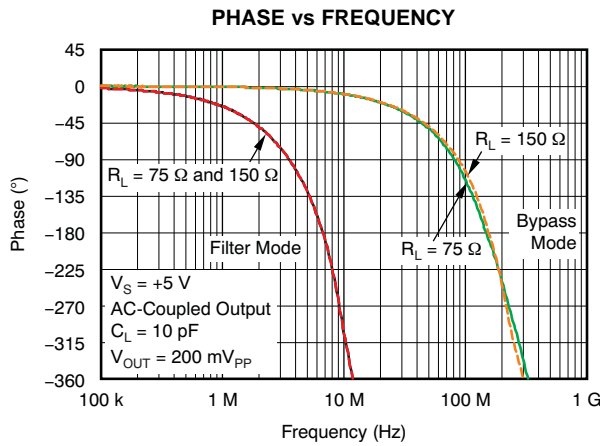

Figure 36.

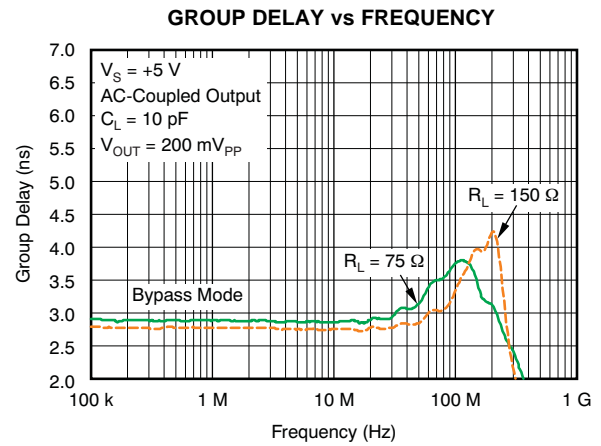

Figure 37.

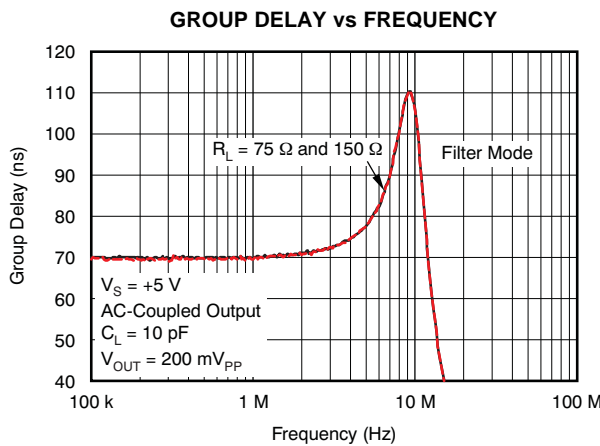

Figure 38.

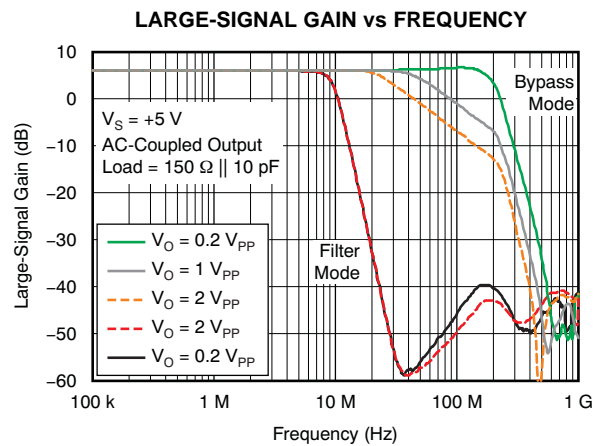

Figure 39.

TYPICAL CHARACTERISTICS: $V_{S+} = 5\text{ V}$ (continued)

$R_L = 150\ \Omega$ to GND and dc-coupled input and output, unless otherwise noted.

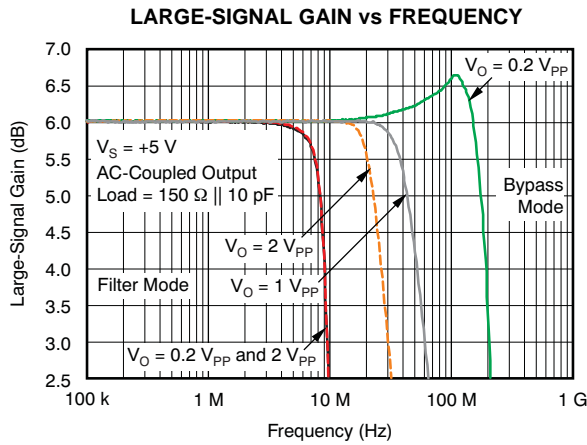

Figure 40.

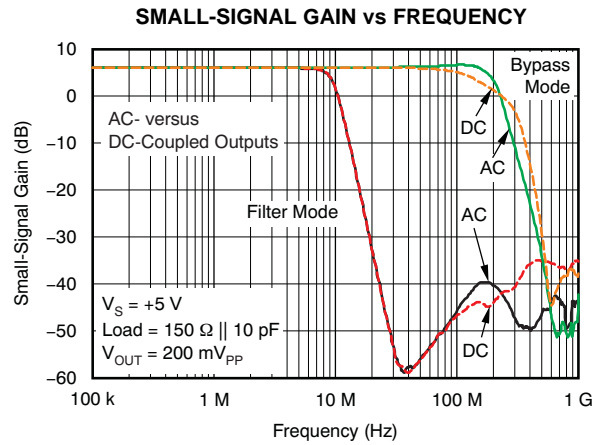

Figure 41.

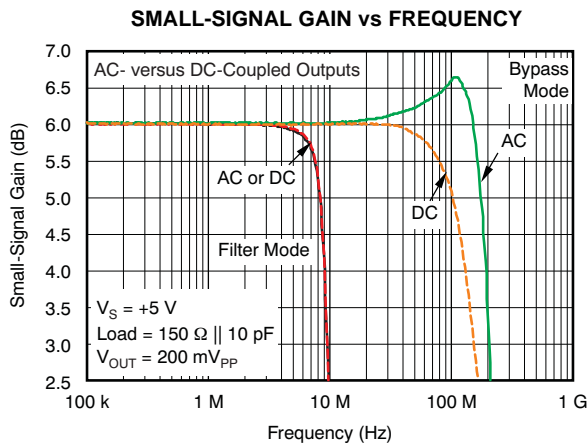

Figure 42.

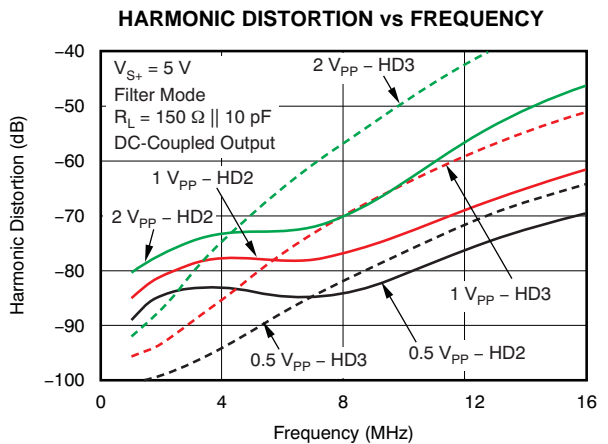

Figure 43.

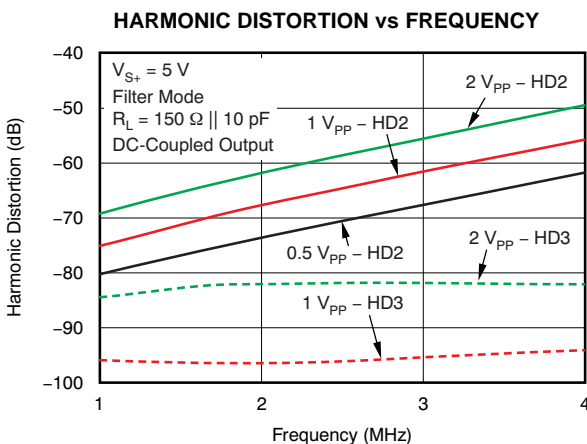

Figure 44.

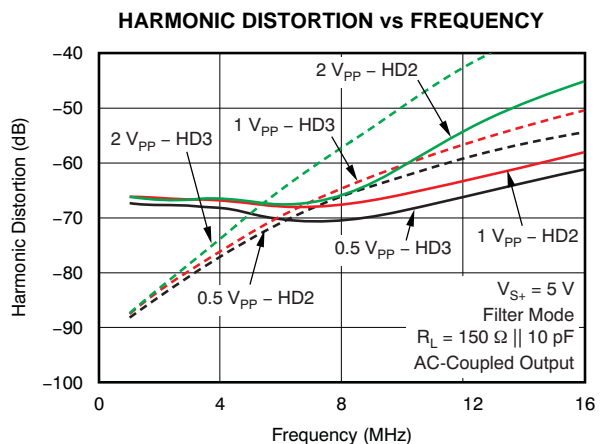

Figure 45.

TYPICAL CHARACTERISTICS: $V_{S+} = 5\text{ V}$ (continued)

$R_L = 150\ \Omega$ to GND and dc-coupled input and output, unless otherwise noted.

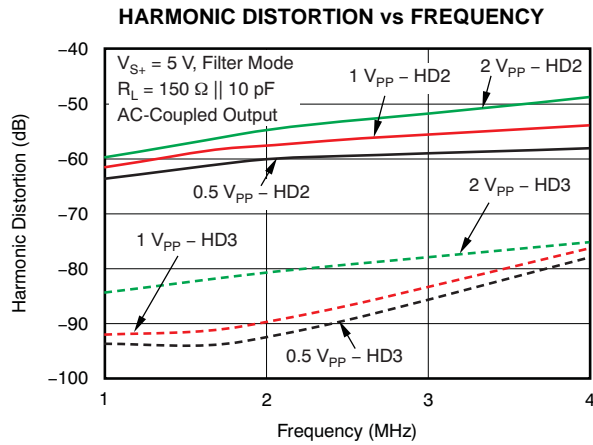

Figure 46.

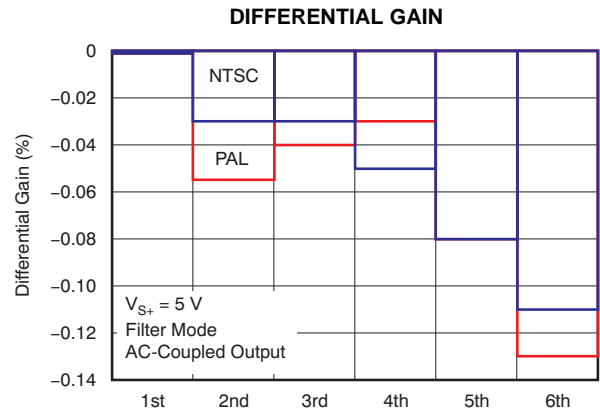

Figure 47.

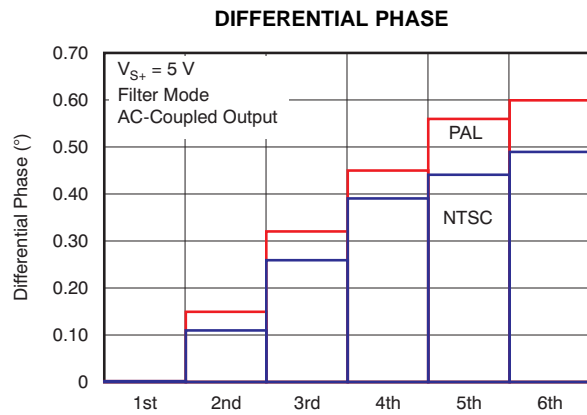

Figure 48.

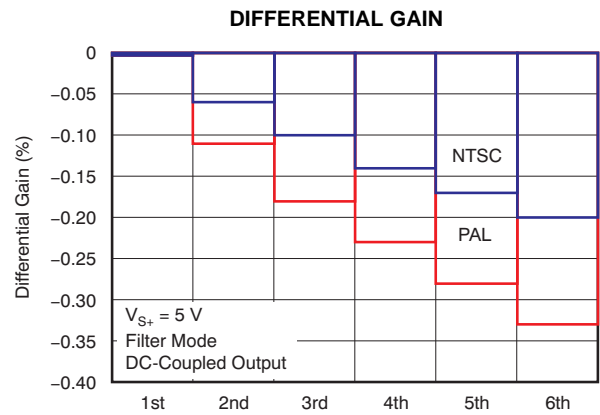

Figure 49.

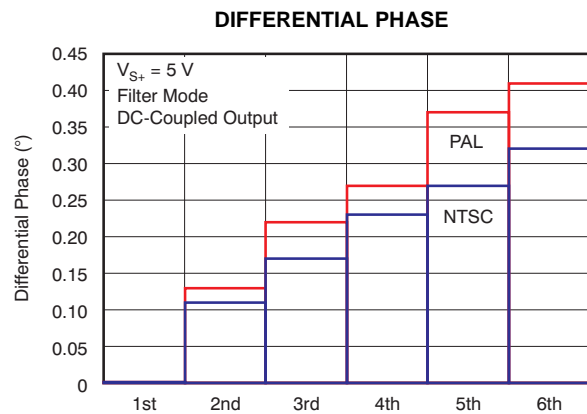

Figure 50.

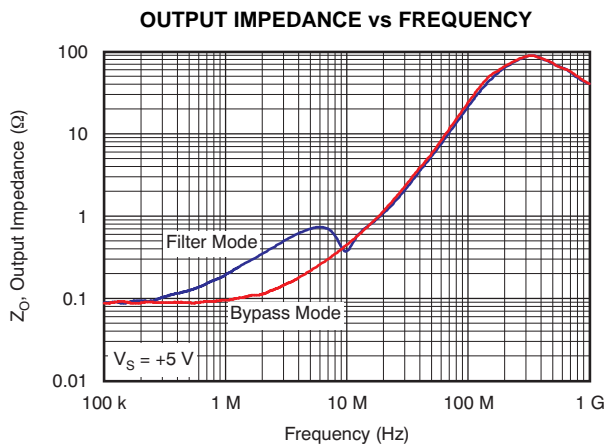

Figure 51.

TYPICAL CHARACTERISTICS: $V_{S+} = 5\text{ V}$ (continued)

$R_L = 150\ \Omega$ to GND and dc-coupled input and output, unless otherwise noted.

S22 OUTPUT REFLECTION COEFFICIENT vs FREQUENCY

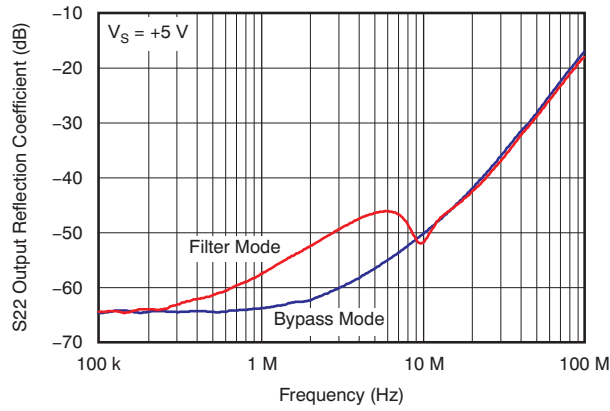

Figure 52.

SMALL-SIGNAL GAIN vs FREQUENCY

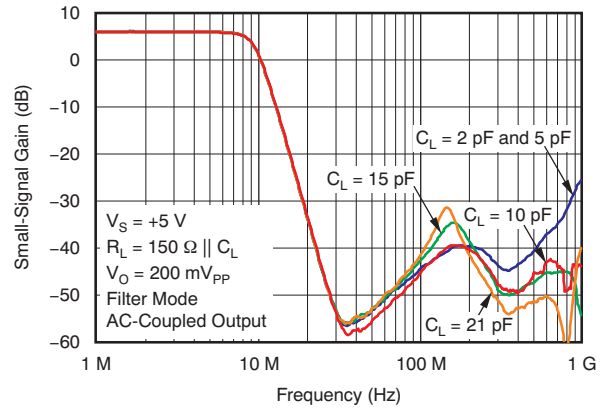

Figure 53.

SMALL-SIGNAL GAIN vs FREQUENCY

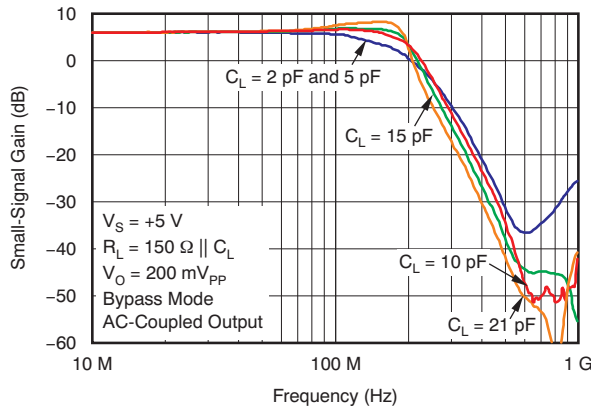

Figure 54.

SMALL-SIGNAL GAIN vs FREQUENCY

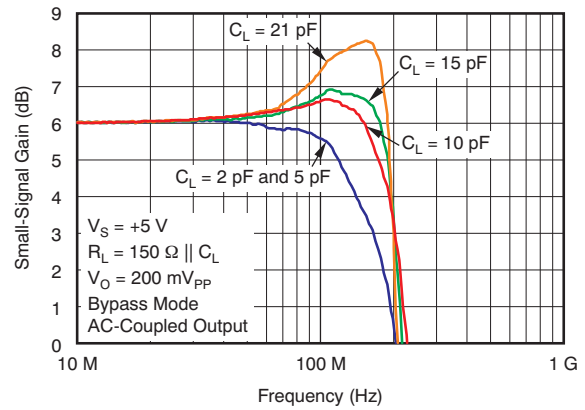

Figure 55.

APPLICATION INFORMATION

The THS7374 is targeted for standard definition video output buffer applications. Although it can be used for numerous other applications, the needs and requirements of the video signal are the most important design parameters of the THS7374. Built on the revolutionary complementary Silicon Germanium (SiGe) BiCom3X process, the THS7374 incorporates many features not typically found in integrated video parts while consuming very low power. The THS7374 has the following features:

- Single-supply 3 V to 5 V operation with low total quiescent current of 9.6-mA at 3.3 V and 10-mA at 5 V.
- 0.1- μ A disable mode allows for shutting down the THS7374 to save system power in power-sensitive applications.
- Input configuration accepts dc + level shift, ac sync-tip clamp, or ac-bias.
- AC-biasing is allowed with the use of a single external pull-up resistor to the positive power supply.
- Sixth-order low-pass filter for DAC reconstruction or ADC image rejection:
 - 9.5-MHz for NTSC, PAL, SECAM, composite (CVBS), s-video Y'C', 480i/576i Y'P'B'P'R, G'B'R', and SCART signals.
- Bypass mode bypasses the low-pass filter with a 150-MHz bandwidth and 130-V/ μ s slew rate amplifier
- Internal fixed gain of 2 V/V (+6 dB) buffer that can drive two video lines per channel with dc-coupling or traditional ac-coupling.
- Signal flow-through configuration in a TSSOP-14 package that complies with the latest lead-free (RoHS-compatible) and green manufacturing requirements.

OPERATING VOLTAGE

The THS7374 is designed to operate from 3-V to 5-V over a -40°C to $+85^{\circ}\text{C}$ temperature range. The impact on performance over the entire temperature range is negligible as a result of the implementation of thin film resistors and high quality, low temperature coefficient capacitors. The design of the THS7374 allows operation down to 2.85 V, but it is recommended to use at least a 3-V supply to ensure no issues with headroom or clipping.

Place a 0.1- μ F to 0.01- μ F capacitor as close as possible to the power-supply pins. Failure to do so may result in ringing or oscillating at the THS7374 outputs. Additionally, a large capacitor (such as 22 μ F to 100 μ F) should be placed on the power-supply line to minimize interference with 50-Hz/60-Hz line frequencies.

INPUT VOLTAGE

The THS7374 input range allows for an input signal range from -0.2 V to about $(V_{S+} - 1.5$ V). However, because of the internal fixed gain of 2 V/V (+6 dB) and the internal level shift of 150 mV nominal, the output is generally the limiting factor for the allowable linear input range. For example, with a 5-V supply, the linear input range is from -0.2 V to 3.5 V. As a result of the gain and level shift, the linear output range limits the allowable linear input range to be from about -0.1 V to 2.3 V.

INPUT OVERVOLTAGE PROTECTION

The THS7374 is built using a very high-speed complementary bipolar and CMOS process. The internal junction breakdown voltages are relatively low for these very small geometry devices. These breakdowns are reflected in the [Absolute Maximum Ratings](#) table. All input and output device pins are protected with internal ESD protection diodes to the power supplies, as shown in [Figure 56](#).

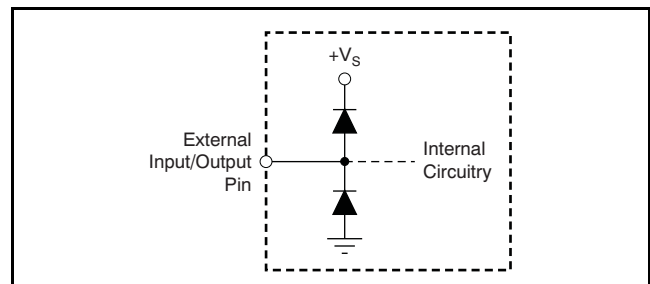

Figure 56. Internal ESD Protection

These diodes provide moderate protection to input overdrive voltages above and below the supplies as well. The protection diodes can typically support 30 mA of continuous current when overdriven.

TYPICAL CONFIGURATION AND VIDEO TERMINOLOGY

A typical application circuit that uses the THS7374 as a video buffer is shown in Figure 57. It shows a DAC or encoder driving the input channels of the THS7374. One channel is a composite video (CVBS) channel of a standard definition (SD) video system. The other channels are the component video $Y'P'_BP'_R$ (sometimes labeled $Y'U'V'$ or incorrectly labeled $Y'C'_BC'_R$) signals of a 480i or 576i system. These channels could easily be the s-video Y'/C' channels or the $R'G'B'$ channels of a SCART system.

Note that the Y' term is used for the luma channels throughout this document rather than the more common luminance (Y) term. The reason for this usage is to account for the definition of luminance as stipulated by the CIE (International Commission on Illumination). Video departs from true luminance because a nonlinear term, gamma, is added to the true RGB signals to form $R'G'B'$ signals. These $R'G'B'$ signals are then used to mathematically create luma (Y'). Thus, luminance (Y) is not maintained, providing a difference in terminology.

This rationale is also used for the chroma (C') term. Chroma is derived from the non-linear $R'G'B'$ terms and thus it is nonlinear. Chrominance (C) is derived from linear RGB, giving the difference between chroma (C') and chrominance (C). The color difference signals ($P'_B/P'_R/U'V'$) are also referenced in this way to denote the nonlinear (gamma corrected) signals.

$R'G'B'$ (commonly mislabeled RGB) is also called $G'B'R'$ (again commonly mislabeled as GBR) in professional video systems. The SMPTE component standard stipulates that the luma information is placed on the first channel, the blue color difference is placed on the second channel, and the red color difference signal is placed on the third channel. This configuration is consistent with the $Y'P'_BP'_R$ nomenclature. Because the luma channel (Y') carries the sync information and the green channel (G') also carries the sync information, it makes logical sense that G' be placed first in the system. Furthermore, because the blue color difference channel (P'_B) is next and the red color difference channel (P'_R) is last, then it also makes logical sense to place the B' signal on the second channel and the R' signal on the third channel respectfully. Thus, hardware compatibility is better achieved when using $G'B'R'$ rather than $R'G'B'$. Note that for many $G'B'R'$ systems, sync is embedded on all three channels, but this may not always be the case in all systems.

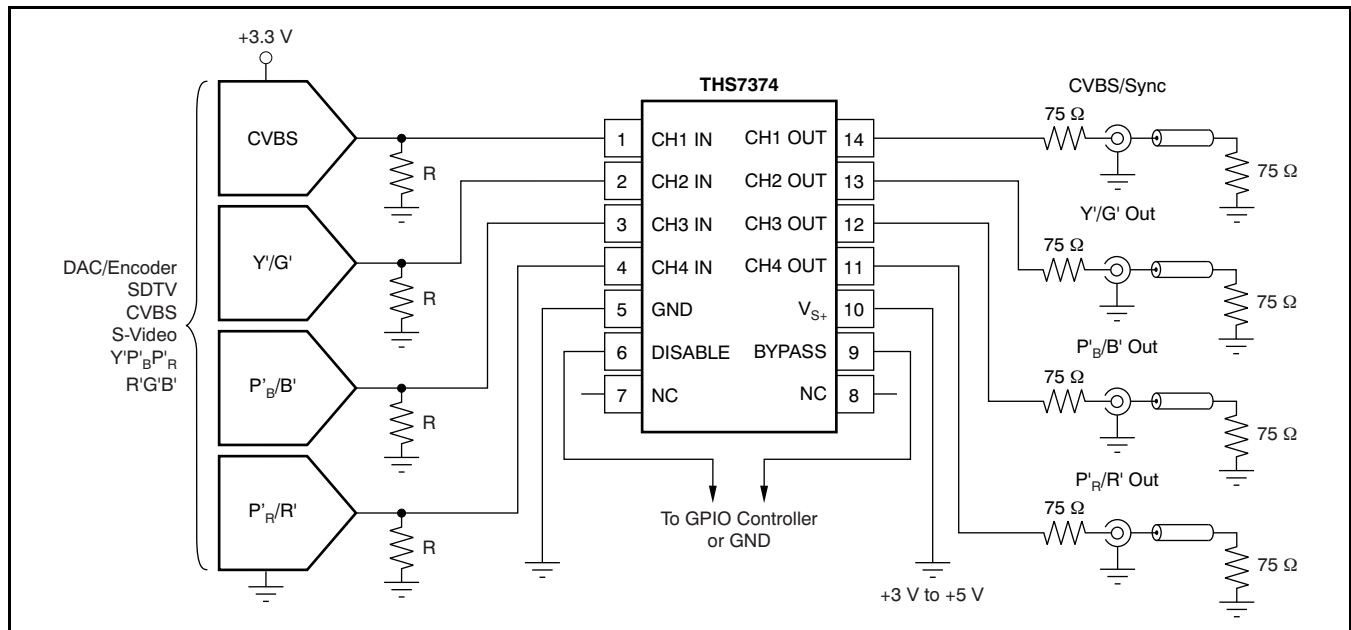

Figure 57. Typical SDTV CVBS/ $Y'P'_BP'_R$ Inputs from DC-Coupled Encoder/DAC with DC-Coupled Line Driving

INPUT MODE OF OPERATION: DC

The THS7374 allows for both ac-coupled and dc-coupled inputs. Many DACs or video encoders can be dc-connected to the THS7374. One of the drawbacks to dc coupling is when 0 V is applied to the input. Although the input of the THS7374 allows for a 0-V input signal with no issues, the output swing of a traditional amplifier cannot yield a 0-V signal, resulting in possible clipping. This condition is true for any single-supply amplifier as a result of the output transistor limitations. Both CMOS and bipolar transistors cannot go to 0 V while sinking current. This characterization of a transistor is also the same reason why the highest output voltage is always less than the power-supply voltage when sourcing current.

This output clipping can reduce the sync amplitudes (both horizontal and vertical sync) on the video signal. A problem occurs if the receiver of this video signal uses an AGC loop to account for losses in the transmission line. Some video AGC circuits derive gain from the horizontal sync amplitude. If clipping occurs on the sync amplitude, then the AGC circuit can increase the gain too much—resulting in too much luma and/or chroma amplitude gain correction. This overcorrection may result in a picture with an overly bright display with too much color saturation.

Other AGC circuits use the chroma burst amplitude for amplitude control, and a reduction in the sync signals does not alter the proper gain setting. However, it is good engineering design practice to ensure that saturation/clipping does not take place. Transistors always take a finite amount of time to come out of saturation. This saturation could possibly result in timing delays or other aberrations on the signals.

To eliminate saturation/clipping problems, the THS7374 has a 150-mV input level shift feature. This feature takes the input voltage and adds an internal +150-mV shift to the signal. Since the THS7374 also has a gain of 6 dB (2 V/V), the resulting output with a 0-V applied input signal is approximately 300 mV. The THS7374 rail-to-rail output stage can create this output level while connected to a typical video load. This feature ensures that no saturation/clipping of the sync signals occur. This shift is constant, regardless of the input signal. For example, if a 1-V input is applied, the output is at 2.3 V.

Because the internal gain is fixed at +6 dB, the gain dictates what the allowable linear input voltage range can be without clipping concerns. For example, if the power supply is set to 3.0 V, the maximum output is approximately 2.9 V while driving a significant amount of current. Thus, to avoid clipping, the allowable input is $[(2.9 \text{ V}/2) - 0.15 \text{ V}] = 1.3 \text{ V}$. This calculation is true for up to the maximum recommended 5-V power supply that allows about a $[(4.9 \text{ V}/2) - 0.15 \text{ V}] = 2.3 \text{ V}$ input range while avoiding clipping on the output.

The input impedance of the THS7374 in this mode of operation is dictated by the internal 800-k Ω pull-down resistor, as shown in Figure 58. Note that the internal voltage shift does not appear at the input pin, but only the output pin. This configuration ensures there is no issue with interfacing to the source.

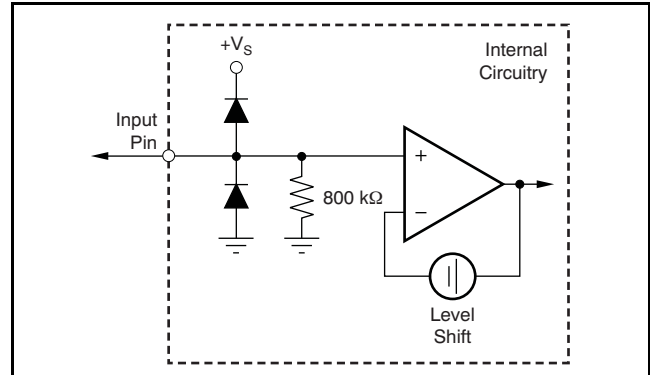

Figure 58. Equivalent DC Input Mode Circuit

INPUT MODE OF OPERATION: AC SYNC TIP CLAMP

Some video DACs or encoders are not referenced to ground but rather to the positive power supply. The resulting video signals are generally too high of a voltage for a dc-coupled video buffer to function properly. To account for this scenario, the THS7374 incorporates a sync-tip clamp (STC) circuit. This function requires a capacitor (nominally 0.1 μF) to be in series with the input. Note that while the term *sync-tip-clamp* is used throughout this document, it should be noted that the THS7374 would probably be better termed to be a *dc restoration circuit* based on how this function is performed. This circuit is an active clamp circuit and not a passive diode clamp function.

The input to the THS7374 has an internal control loop that sets the lowest input applied voltage to clamp at ground (0 V). By setting the reference at 0-V, the THS7374 allows a dc-coupled input to also function. Therefore, the STC is considered transparent because it does not operate unless the input signal goes below ground. The signal then goes through the same 150-mV level shifter, resulting in an output voltage low level of 300 mV. If the input signal tries to go below 0 V, the internal control loop of the THS7374 sources up to 3-mA of current to increase the input voltage level on the THS7374 input side of the coupling capacitor. As soon as the voltage goes above the 0-V level, the loop stops sourcing current and becomes very high impedance.

To ensure proper stability of the ac STC control loop, the source impedance must be less than 1-k Ω with the input capacitor in place. Otherwise, there is a possibility for the control loop to ring; this ringing may appear on the THS7374 output. Because most DACs or encoders use resistors to establish the voltage, which are typically less than 300- Ω , meeting the less than 1-k Ω requirement is easily done. However, if the source impedance looking from the THS7374 input perspective is very high, simply adding a 1-k Ω resistor to GND ensures proper operation of the THS7374.

INPUT MODE OF OPERATION: AC BIAS

Sync tip clamps are ideal for signals that have horizontal and/or vertical syncs associated with them. However, some video signals do not have a sync embedded within the signal. If ac-coupling of these signals is desired, then a dc bias is required to properly set the dc operating point within the THS7374. This function is easily accomplished with the THS7374 by simply adding an external pull-up resistor to the positive power supply, as shown in Figure 60.

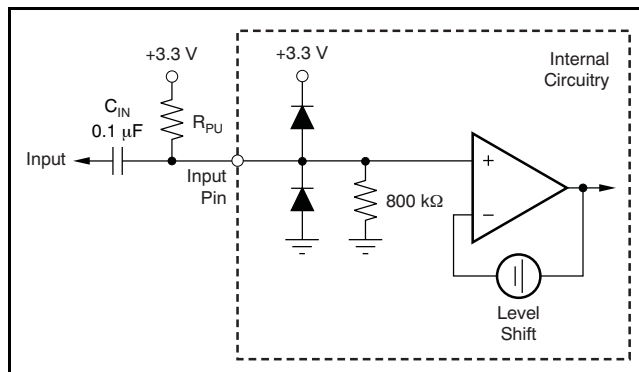

Figure 60. AC-Bias Input Mode Circuit Configuration

The dc voltage that appears at the input pin is equal to Equation 1:

$$V_{DC} = V_S \left[\frac{800 \text{ k}\Omega}{800 \text{ k}\Omega + R_{PU}} \right] \quad (1)$$

The THS7374 allowable input range is approximately 0 V to ($V_{S+} - 1.5 \text{ V}$), which allows for a very wide input voltage range. As such, the input dc bias point is very flexible; the output dc bias point is the primary factor. For example, if the output dc bias point is desired to be mid-rail on a 3.3-V supply, then the input dc bias point is recommended to be (1.6 V –

300 mV)/2 = 0.65 V. Thus, the pull-up resistor calculates to a standard 3.3-M Ω resistor, resulting in 0.644 V. If the output dc-bias point is desired to be 1.6 V with a 5-V power supply, then the pull-up resistor value calculates to be approximately 5.36-M Ω .

Keep in mind that the internal 800-k Ω resistor has a $\pm 20\%$ variance. As such, the calculations should take this variance into account. For the 0.644-V input bias voltage example above using an ideal 3.3-M Ω resistor, the input dc bias voltage is about 0.644 V ($\pm 0.1 \text{ V}$).

The value of the output bias is very flexible and is left to each individual design. It is important to ensure that the signal does not clip or saturate the video signal. Thus, it is recommended to ensure the output bias voltage is between 0.9 V and ($V_{S+} - 1 \text{ V}$). For 100% color saturated CVBS or signals with Macrovision, the CVBS signal can reach up to 1.23 V_{PP} input, or 2.46 V_{PP} output. In contrast, other signals are typically 0.7 V_{PP} input, or 1.4 V_{PP} output. As such, the output bias voltage must account for a worst-case situation depending on the potential signals.

One other issue that must be taken into account is the dc-bias point as a function of the power supply. As such, there is an impact on the system PSRR. To help reduce this impact, the input capacitor combines with the pull-up resistance to function as a low-pass filter. Additionally, the time to charge the capacitor to the final dc bias point is also a function of the pull-up resistor and the input capacitor. Lastly, the input capacitor forms a high-pass filter with the parallel impedance of the pull-up resistor and the 800-k Ω resistor. In general, it is good to have this high-pass filter at approximately 3-Hz to minimize any potential droop on a P'_B, P'_R, or non-sync B' or R' signal. A 0.1- μF input capacitor with a 3.3-M Ω pull-up resistor equates to a 2.5-Hz high-pass corner frequency.

This mode of operation is recommended for use with chroma (C'), P'_B, P'_R, U', V', and non-sync R'G'B' signals. This method can also be utilized with signals with sync if desired. The benefit of using the STC function is that it maintains a constant *back porch* voltage as opposed to a *back porch* voltage that fluctuates depending on the video content. Because the corner frequency of the input is a very low 2.5 Hz, then this is still very good performance, but not as good relative to a STC configuration.

OUTPUT MODE OF OPERATION: DC COUPLED

The THS7374 incorporates a rail-to-rail output stage that can be used to drive the line directly without the need for large ac coupling capacitors, as shown in Figure 61. This approach offers the best line tilt and field tilt (or droop) performance because no ac coupling occurs. Keep in mind that if the input is ac-coupled, then the resulting tilt because of the input ac coupling is seen on the output regardless of the output coupling. The 80-mA output current drive capability of the THS7374 was designed to drive two video lines simultaneously (essentially, a 75- Ω load) while maintaining as wide an output dynamic range as possible.

One concern of dc coupling, however, arises if the line is terminated to ground. If the ac-bias input configuration is used, the output of the THS7374 has a dc bias on the output. With two lines terminated to ground, this configuration creates a dc current path that results in a slightly decreased high output voltage swing and an increase in power dissipation of the THS7374. While the THS7374 was designed to operate with a junction temperature of up to +125°C,

care must be taken to ensure that the junction temperature does not exceed this level; otherwise, long-term reliability could suffer. Although this configuration only adds less than 10 mW of power dissipation per channel, the overall low-power dissipation of the THS7374 design minimizes potential thermal issues even when using the TSSOP package at high ambient temperatures.

Note that the THS7374 can drive the line with dc coupling regardless of the input mode of operation. The only requirement is to make sure the video line has proper termination in series with the output—typically 75- Ω . This termination helps isolate capacitive loading effects from the THS7374 output. Failure to isolate capacitive loads may result in instabilities with the output buffer, potentially causing ringing or oscillations to appear. The stray capacitance appearing directly at the THS7374 output pins should be kept below 20-pF. The best way to ensure this limit is maintained is to place the 75- Ω series output resistor as close as possible to the output pin. If an output capacitor is used, as discussed in the next section, then it should be placed after the resistor.

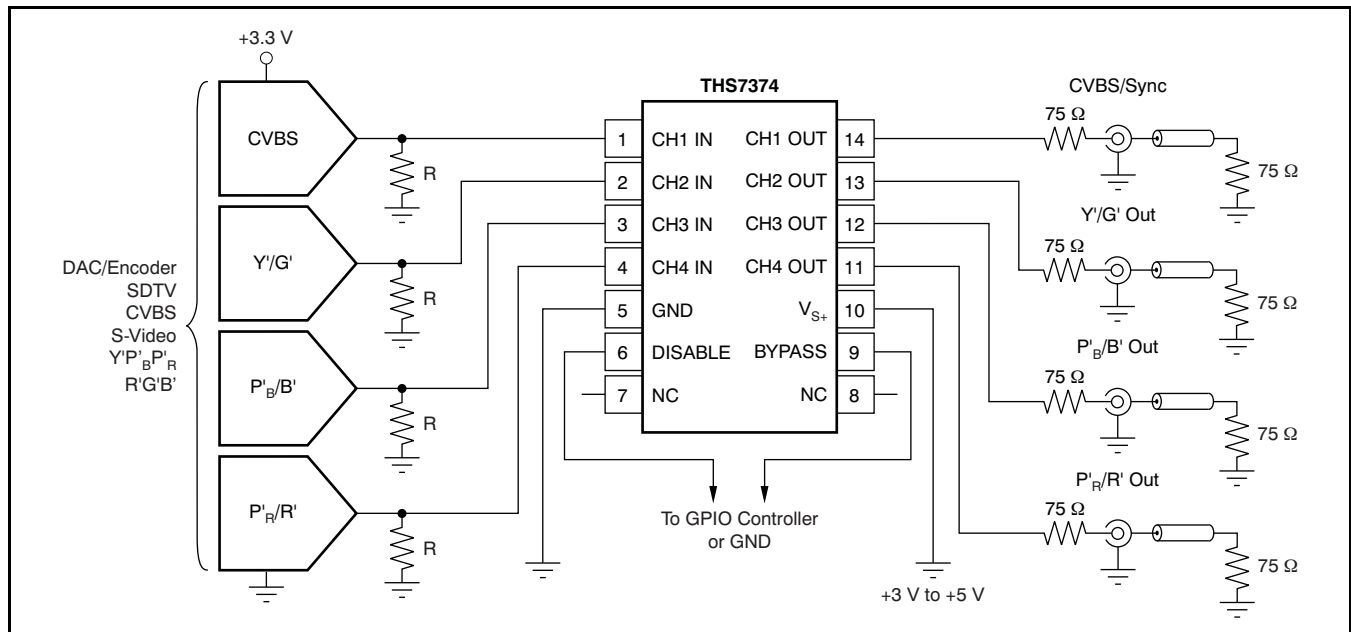

Figure 61. Typical SDTV System with DC-Coupled Line Driving

OUTPUT MODE OF OPERATION: AC COUPLED

A very common method of coupling the video signal to the line is the use of a large capacitor. This capacitor is typically between 220 μF and 1000 μF , although 470 μF is very common. The value of this capacitor must be large enough to minimize the line tilt (droop) and/or field tilt associated with ac coupling as described previously in this document. AC coupling is done for several reasons, but most often to ensure full interoperability with the receiving video system. AC coupling also ensures adherence to video standard specifications. It ensures that regardless of the reference dc voltage used on the transmit side, the receive side re-establishes the dc reference voltage to its own requirements.

As with the dc output mode of operation discussed previously, each line should have a 75- Ω source termination resistor in series with the ac coupling capacitor. If two lines are to be driven, it is best to have each line use its own capacitor and resistor rather than sharing these components, as shown in Figure 62.

This configuration helps ensure line-to-line dc isolation and avoids the potential problems discussed above. Using a single 1000- μF capacitor for two lines can be done, but there is a chance for ground loops and interference to be created between the two receivers.

Lastly, because of the edge rates and frequencies of operation, it is recommended (but not required) to place a 0.1- μF to 0.01- μF capacitor in parallel with the large 220- μF to 1000- μF capacitor. These large-value capacitors are generally aluminum electrolytic. It is well-known that these capacitors have significantly large equivalent series resistance (ESR), and the impedance at high frequencies is rather large because of the associated inductances involved with the leads and construction. The small 0.1- μF to 0.01- μF capacitors help pass these high-frequency (> 1-MHz) signals with much lower impedance than the large capacitors.

Although it is common to use the same capacitor values for all the video lines, the frequency bandwidth of the chroma signal in a s-video system are not required to go as low (or as high of a frequency) as the luma channels. Thus, the capacitor values of the chroma line(s) can be smaller, such as 0.1 μF .

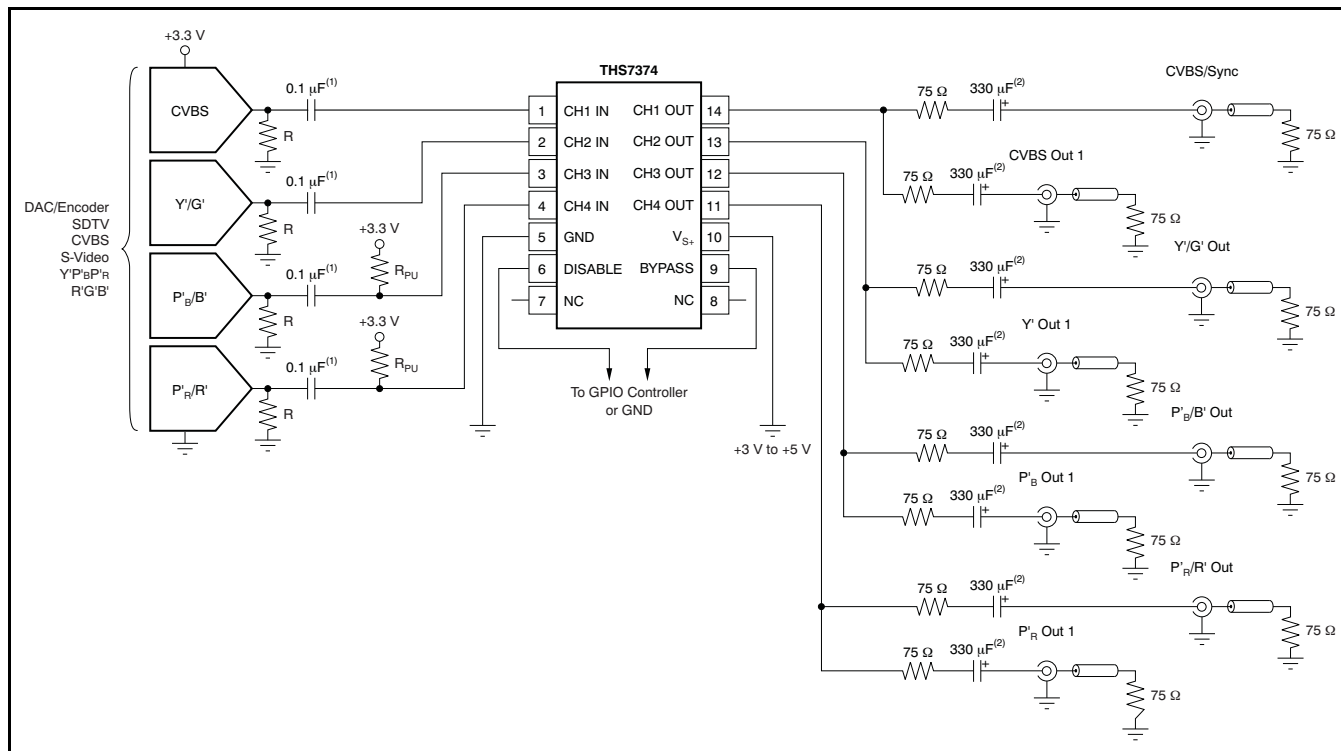

(1) An ac-coupled input is shown in this example. DC coupling is also allowed as long as the DAC output voltage is within the allowable linear input and output voltage range of the THS7374. To dc-couple, remove the 0.1 μF input capacitors and R_{PU} .

(2) An ac-coupled output is shown in this example. DC coupling is also allowed by simply removing these capacitors.

Figure 62. Typical SDTV AC-Input System Driving Two AC-Coupled Video Lines

Low-Cost SCART System

The THS7374 is an ideal device for use in low-cost SCART systems. SCART is used primarily throughout Europe and requires four video channels to support the RGB and timing channel. The timing channel is also utilized for CVBS signals for systems that do not have separate RGB video signals. The connector also adds audio and several other functions. Figure 63 shows a low-cost application that allows for a commonly-used SCART switching interface with a simple CD4053 switch. The relatively high impedance

of this switch is acceptable in this configuration, because the input impedance of the THS7374 is 800 kΩ and the audio signal impedance requirement is less than 1 kΩ. Obviously, other switches and methods could be used, but this alternative is very low cost compared to fairly expensive SCART switching ICs. It does not support all possible modes and configurations, but it is a good fit to meet many system requirements.

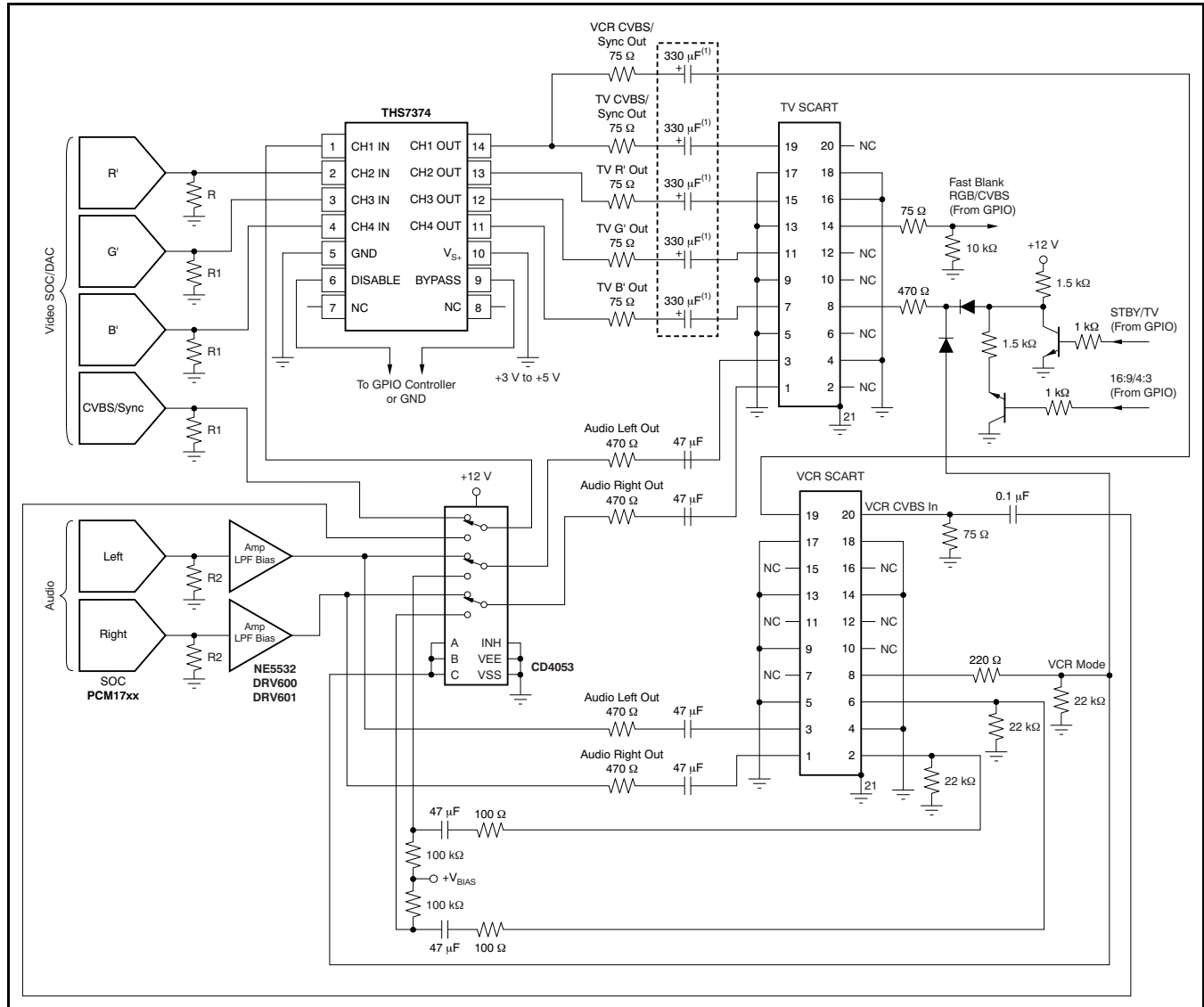

(1) These capacitors are optional.

Figure 63. Low-Cost SCART Switching System Circuit

LOW-PASS FILTER

Each channel of the THS7374 incorporates a sixth-order low-pass filter. These video reconstruction filters minimize DAC images from being passed onto the video receiver. Depending on the receiver design, failure to eliminate these DAC images can cause picture quality problems as a result of ADC aliasing. Another benefit of the filter is to smooth out aberrations in the signal which some DACs can have if the internal device filtering is not very good. This technique helps with picture quality and helps ensure that the signal meets video bandwidth requirements.

Each filter has an associated Butterworth characteristic. The benefit of the Butterworth response is that the frequency response is flat, with a relatively steep initial attenuation at the corner frequency. The problem is that the group delay rises near the corner frequency. Group delay is defined as the change in phase (radians/second) divided by a change in frequency. An increase in group delay corresponds to a time domain pulse response that has overshoot and some possible ringing associated with the overshoot.

The use of other type of filters, such as elliptic or chebyshev, are not recommended for video applications because of the very large group delay variations near the corner frequency, resulting in significant overshoot and ringing. While these elliptic or chebyshev filters may help meet the video standard specifications with respect to amplitude attenuation, the group delay is well beyond the standard specifications. When considering these filter types, keep in mind that video can go from a white pixel to a black pixel over and over again, and ringing can easily occur. Ringing typically causes a display to have ghosting or fuzziness appear on the edges of a sharp transition. On the other hand, a Bessel filter has ideal group delay response, but the rate of attenuation is typically too low for acceptable image rejection. Thus, the Butterworth filter is a respectable compromise for both attenuation and group delay.

The THS7374 filters have a nominal corner (-3 dB) frequency at 9.5-MHz and a -1 dB passband typically at 8.2-MHz. This 9.5-MHz filter is ideal for standard definition (SD) NTSC, PAL, and SECAM composite video (CVBS) signals. It is also useful for s-video signals (Y'C'), 480i/576i Y'P_BP_R, Y'U'V', broadcast G'B'R' (R'G'B') signals, and computer video signals. The 9.5-MHz -3 dB corner frequency was designed to achieve 54-dB of attenuation at 27-MHz—a common sampling frequency between the DAC/ADC second and third Nyquist zones found in many video systems. This consideration is important because any signal appearing around this frequency can appear in the baseband as a result of aliasing effects of an ADC found in a receiver.

Keep in mind that images do not stop at 27-MHz; they continue around the sampling frequencies of 54-MHz, 81-MHz, 108-MHz, etc. Because of these multiple images that an ADC can fold down into the baseband signal, the low-pass filter must also eliminate these higher-order images. The THS7374 has 60-dB attenuation at 54-MHz, 55-dB attenuation at 81-MHz, and 50-dB attenuation at 108-MHz. Attenuation above 108-MHz is at least 45-dB, which makes sure that images do not affect the desired video baseband signal.

The 9.5-MHz filter frequency was chosen to account for process variations in the THS7374. To ensure that the required video frequencies are effectively passed, the filter corner frequency must be high enough to allow component variations. The other consideration is the attenuation must be large enough to ensure the anti-aliasing/reconstruction filtering is enough to meet the system demands. Thus, the filter frequencies were not arbitrarily selected and are a good compromise that should meet the demands of most systems.

Benefits Over Passive Filtering

Two key benefits of using an integrated filter system, such as the THS7374, over a passive system is PCB area and filter variations. The small TSSOP-14 package for four video channels is much smaller over a passive RLC network, especially a six-pole passive network. Additionally, consider that inductors have at best $\pm 10\%$ tolerances (normally $\pm 15\%$ to $\pm 20\%$ are common) and capacitors typically have $\pm 10\%$ tolerances. Using a Monte Carlo analysis shows that the filter corner frequency (-3 dB), flatness (-1 dB), Q factor (or peaking), and channel-to-channel delay have wide variations. This approach can lead to potential performance and quality issues in mass-production environments. The THS7374 solves most of these problems with only the corner frequency being essentially the only variable.

Another concern about passive filters is the use of inductors. Inductors are magnetic components and are therefore susceptible to electromagnetic coupling/interference (EMC/EMI). Some common coupling can occur because of other nearby video channels that use inductors for filtering, or it can come from nearby switch-mode power supplies. Some other forms of coupling could be from outside sources with strong EMI radiation which can cause failure in EMC testing such as required for CE compliance.

One concern about an active filter in an integrated circuit is the variation of the filter characteristics when the ambient temperature and the subsequent die temperature changes. To minimize temperature effects, the THS7374 uses low temperature coefficient resistors and high quality—low temperature coefficient capacitors found in the

BiCom3X process. The filters have been specified by design to account for process variations and temperature variations to maintain proper filter characteristics. This architecture maintains a low channel-to-channel time delay, which is required for proper video signal performance.

Another benefit of the THS7374 over a passive RLC filter is the input and output impedance. The input impedance presented to the DAC vary significantly, from 35- Ω to over 1.5-k Ω , with a passive network and may cause voltage variations over frequency. The THS7374 input impedance is 800-k Ω and only the 2-pF input capacitance plus the PCB trace capacitance impacting the input impedance. As such, the voltage variation appearing at the DAC output is better controlled with a fixed termination resistor and the high input impedance buffer of the THS7374.

On the output side of the filter, a passive filter also has a large impedance variation over frequency, again from 35- Ω to over 1.5-k Ω . The THS7374 is an operational amplifier which approximates an ideal voltage source. A voltage source is desirable because the output impedance is very low and can source and sink current. To properly match the transmission line characteristic impedance of a video line, a 75- Ω series resistor is placed on the output. To minimize reflections and to maintain a good return loss, this output resistor must maintain a 75- Ω

impedance. A passive filter impedance variation cannot ensure this while the THS7374 has about 0.7- Ω of output impedance at 5-MHz. Thus, the system is matched much better with a THS7374 compared to a passive filter.

One final advantage of the THS7374 over a passive filter is power dissipation. A DAC driving a video line must be able to drive a 37.5- Ω load—the receiver 75- Ω resistor and the 75- Ω source impedance matching resistor next to the DAC to maintain the source impedance requirement. This approach forces the DAC to drive at least $1.25 V_P$ (100% saturation CVBS)/37.5 Ω = 33.3 mA. A DAC is a current steering element and this amount of current flows internally to the DAC even if the output is 0-V. Thus, power dissipation in the DAC may be very high, especially when four channels are being driven. With a high input impedance and the capability to drive up to two video lines, utilizing the THS7374 can reduce the DAC power dissipation significantly. This occurs because the resistance the DAC is driving can be substantially increased. It is common to set this in a DAC by a current setting resistor on the DAC. Thus, the resistance can be 300- Ω or more, substantially reducing the current drive demands from the DAC and saving a substantial amount of power. For example, a 3.3-V four-channel DAC dissipates 440 mW just for the steering current capability (four channels \times 33.3 mA \times 3.3 V) if it needs to drive 37.5- Ω load. With a 300- Ω load, the DAC power dissipation as a result of current steering current would only be 55 mW (four channels \times 4.16 mA \times 3.3 V).

EVALUATION MODULE

To evaluate the THS7374, an evaluation module (EVM) is available. The EVM allows for testing the THS7374 in many different configuration. Inputs and outputs include BNC connectors commonly found in video systems along with 75- Ω input termination resistors, 75- Ω series source termination resistors, and 75- Ω characteristic impedance traces. Several unpopulated component pads are found on the EVM to allow for different input and output configurations as dictated by the user. This EVM is designed to be used with single supply from 2.85 V up to 5 V.

The EVM default input configuration sets all channels for dc input coupling. The input signal must be within 0 V to about 1.4 V for proper operation. Failure to be within this range will saturate and/or clip the output signal. If the input range is beyond this, or if the signal voltage is unknown, or coming from a current sink DAC, then ac input configuration is desired. This is easily accomplished with the EVM by simply replacing Z1, Z2, Z3, and Z4 0- Ω resistors with 0.1- μ F capacitors.

For ac-coupled input and sync-tip clamp (STC) functionality commonly used for CVBS, s-video Y', component Y' signals, and R'G'B' signals with embedded sync, then no other changes are needed. However, if a bias voltage is needed after the input capacitor which is commonly needed for s-video C', component P_B and P_R, and non-sync embedded R'G'B' signals, then a pull-up resistor should be

added to the signal on the EVM. This is easily done by simply adding a resistor to any of the following resistor pads; RX1, RX3, RX5, or RX7. A common value to use is 3.3-M Ω . Note that even signals with embedded sync can also use bias mode if desired.

The EVM default output configuration sets all channels for ac output coupling. The 470- μ F and 0.1- μ F capacitors work well for most ac-coupled systems. However, if dc coupled output is desired, then replacing the 0.1- μ F capacitors—C12, C14, C16, and C17—with 0- Ω resistors works well. Removing the 470- μ F capacitors is optional, but removing them from the EVM will eliminate a few picofarads of stray capacitance on each signal path which may be desirable.

The THS7374 incorporates an easy method to configure the bypass mode and the disable mode. The use of JP1 controls the disable feature while JP4 controls the bypass feature. While there is a space on the EVM for JP2 and JP3, these are not utilized for the THS7374. Connection of JP1 to GND applies 0 V to the disable pin and the THS7374 operates normally. Moving JP1 to +V_S causes the THS7374 to be in disable mode. Connection of JP4 to GND places the THS7374 in filter mode while moving JP4 to +V_S places the THS7374 in bypass mode.

[Figure 64](#) shows the THS7374EVM schematic. [Figure 65](#) and [Figure 66](#) illustrate the two layers of the EVM PCB, incorporating standard high-speed layout practices. [Table 2](#) lists the bill of materials as supplied from Texas Instruments.

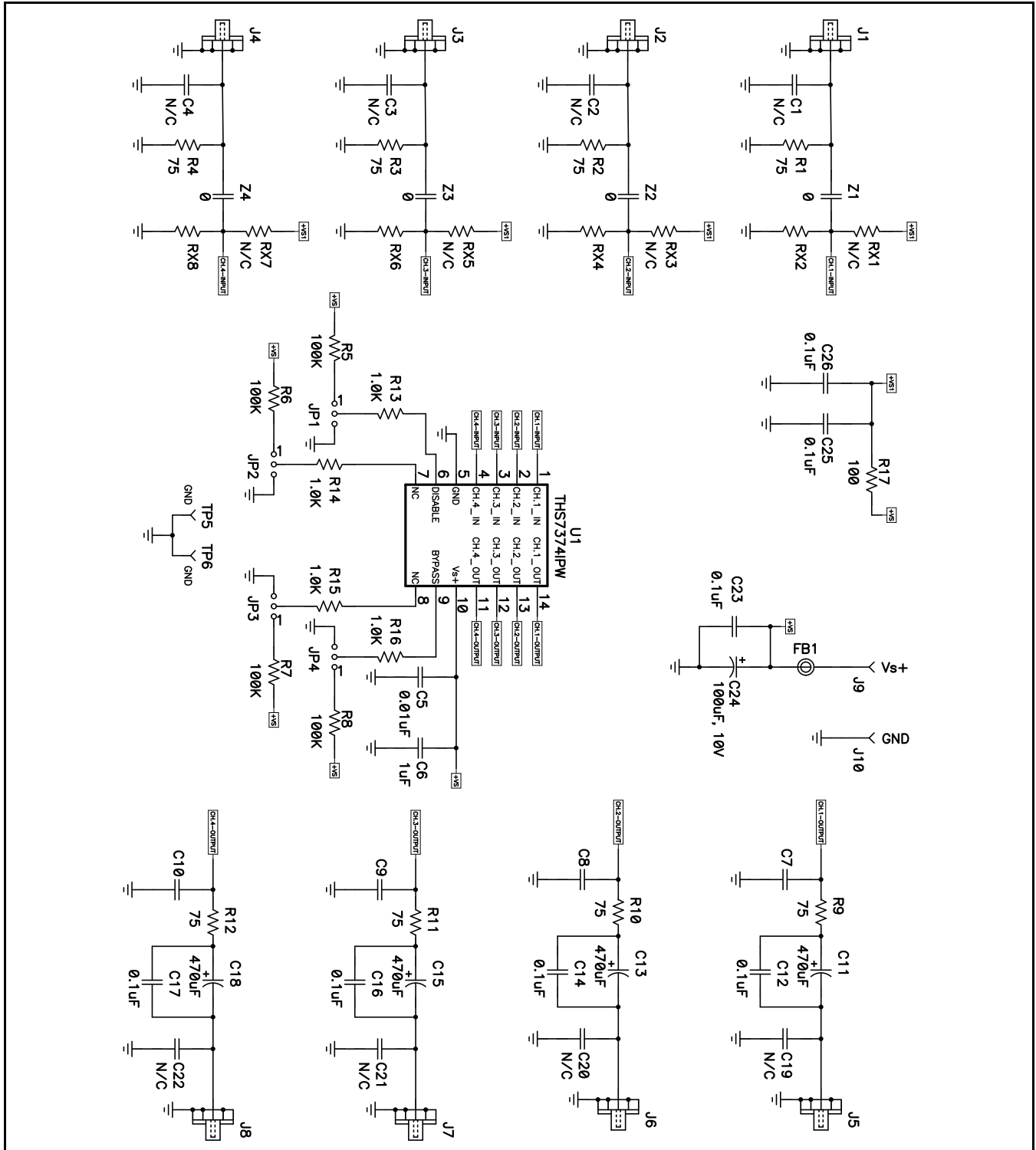

Figure 64. THS7374 EVM Schematic

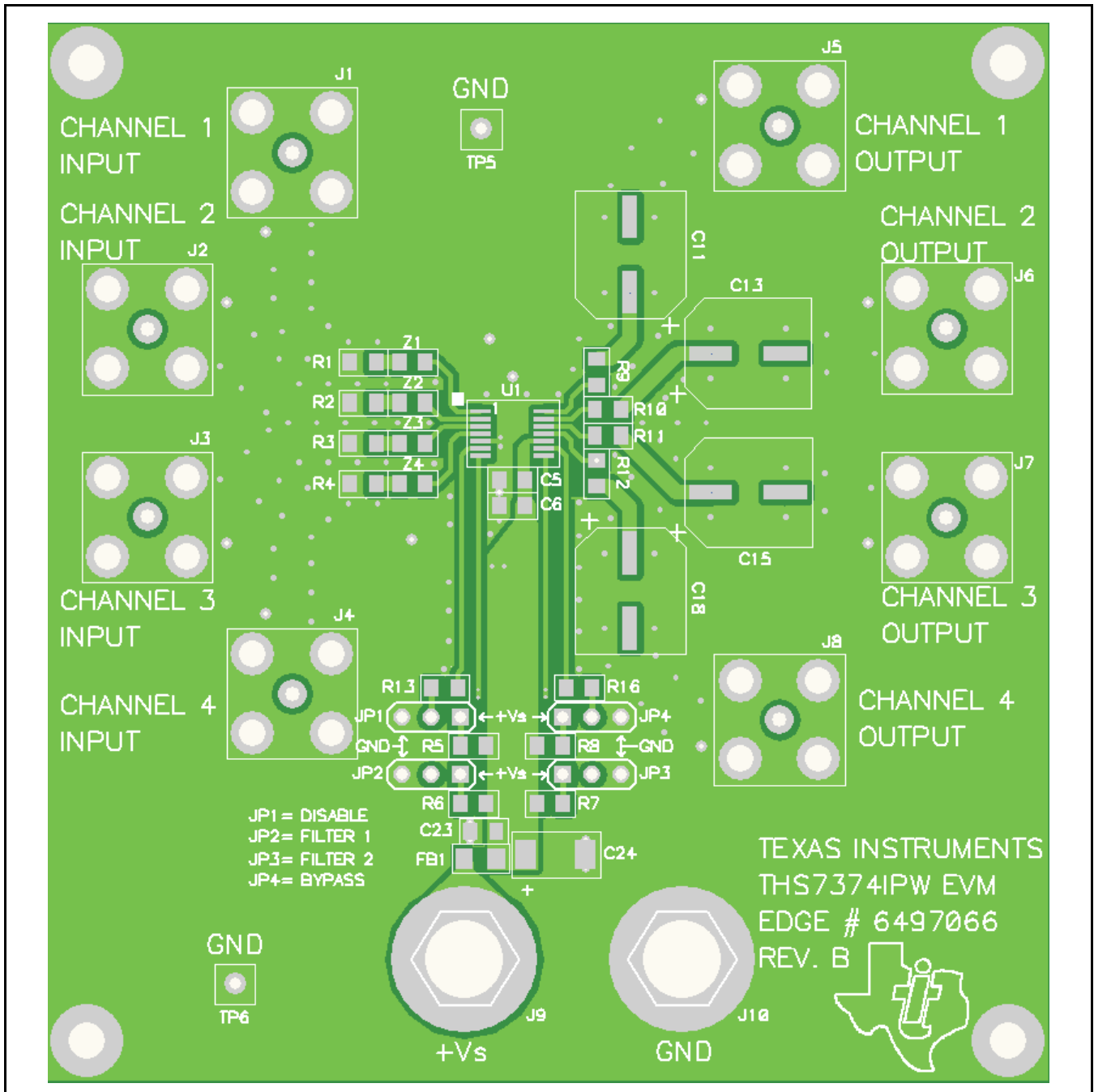

Figure 65. THS7374 EVM PCB Top Layer

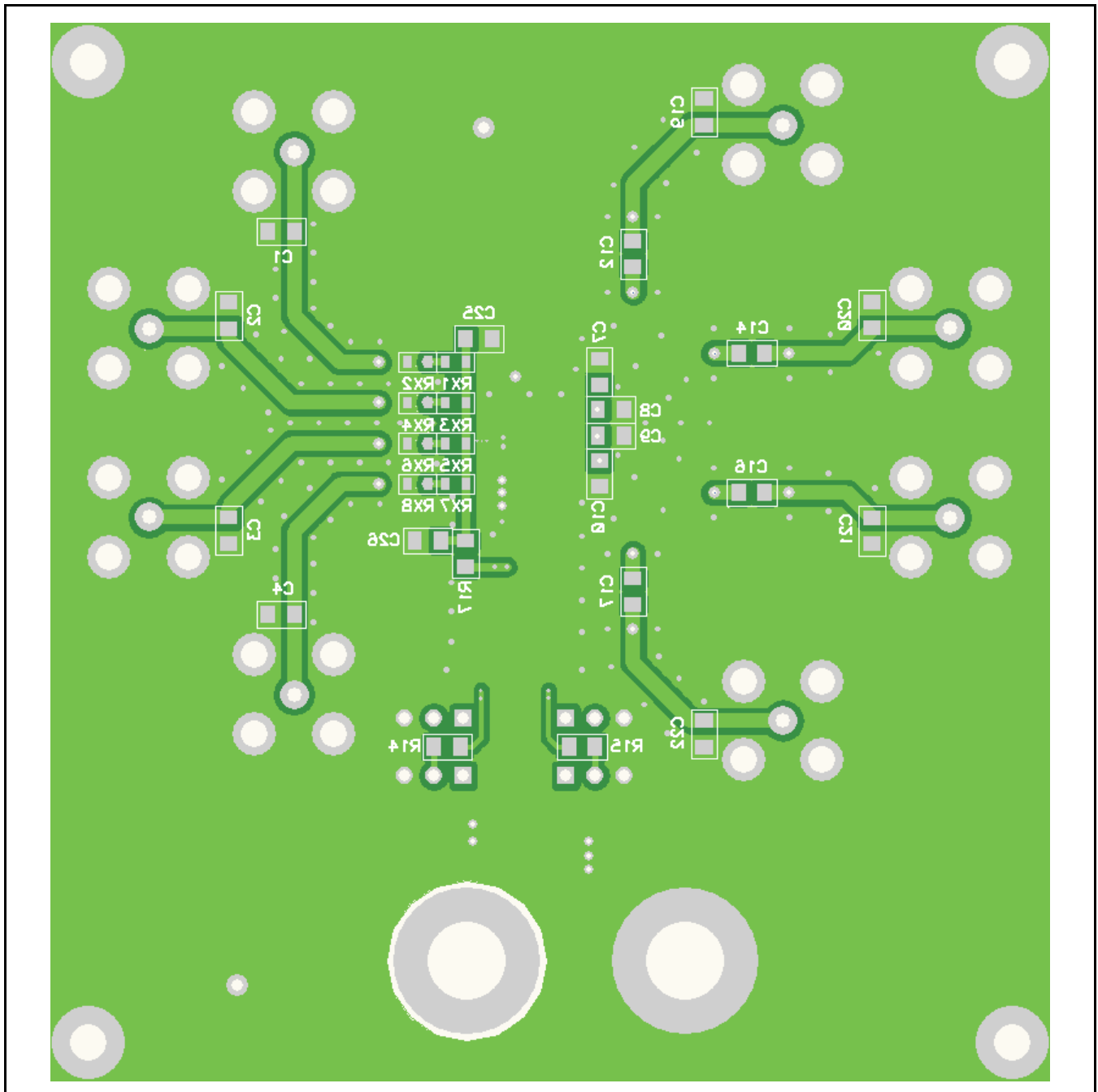

Figure 66. THS7374 EVM PCB Bottom Layer

THS7374EVM Bill of Materials
Table 2. THS7374 EVM

| ITEM | REF DES | QTY | DESCRIPTION | SMD SIZE | MANUFACTURER PART NUMBER | DISTRIBUTOR PART NUMBER |
|------|---|-----|---|------------|---------------------------|------------------------------|
| 1 | FB1 | 1 | Bead, Ferrite, 2.5 A, 330 Ω | 0805 | (TDK) MPZ2012S331A | (Digi-Key) 445-1569-1-ND |
| 2 | C24 | 1 | Capacitor, 100 μF, Tantalum, 10 V, 10%, Low-ESR | C | (AVX) TPSC107K010R0100 | (Digi-Key) 478-1765-1-ND |
| 3 | C1–C4, C7–C10, C19, C20–C22 | 12 | Open | 0805 | | |
| 4 | C5 | 1 | Capacitor, 0.01 μF, Ceramic, 100 V, X7R | 0805 | (AVX) 08051C103KAT2A | (Digi-Key) 478-1358-1-ND |
| 5 | C12, C14, C16, C17, C23, C25, C26 | 7 | Capacitor, 0.1 μF, Ceramic, 50 V, X7R | 0805 | (AVX) 08055C104KAT2A | (Digi-Key) 478-1395-1-ND |
| 6 | C6 | 1 | Capacitor, 1 μF, Ceramic, 16 V, X7R | 0805 | (TDK) C2012X7R1C105K | (Digi-Key) 445-1358-1-ND |
| 7 | C11, C13, C15, C18 | 4 | Capacitor, Aluminum, 470 μF, 10 V, 20% | F | (Cornell) AFK477M10F24B-F | (Newark) 66K0965 |
| 8 | RX1–RX8 | 8 | Open | 0603 | | |
| 9 | R6, R7, R14, R15 | 4 | Open | 0805 | | |
| 10 | Z1–Z4 | 4 | Resistor, 0 Ω | 0805 | (ROHM) MCR10EZHZJ000 | (Digi-Key) RHM0.0ACT-ND |
| 11 | R1–R4, R9–R12 | 8 | Resistor, 75 Ω, 1/8 W, 1% | 0805 | (ROHM) MCR10EZHF75.0 | (Digi-Key) RHM75.0CCT-ND |
| 12 | R17 | 1 | Resistor, 100 Ω, 1/8 W, 1% | 0805 | (ROHM) MCR10EZHF1000 | (Digi-Key) RHM100CCT-ND |
| 13 | R13, R16 | 2 | Resistor, 1 kΩ, 1/8 W, 1% | 0805 | (ROHM) MCR10EZHF1001 | (Digi-Key) RHM1.00KCCT-ND |
| 14 | R5, R8 | 2 | Resistor, 100 kΩ, 1/8 W, 1% | 0805 | (ROHM) MCR10EZHF1003 | (Digi-Key) RHM100KCCT-ND |
| 15 | J9, J10 | 2 | Jack, Banana Receptance, 0.25" dia. hole | | (SPC) 813 | (Newark) 39N867 |
| 16 | J1–J8 | 8 | Connector, BNC, Jack, 75 Ω | | (Amphenol) 31-5329-72RFX | (Newark) 93F7554 |
| 17 | TP5, TP6 | 2 | Test Point, Black | | (Keystone) 5001 | (Digi-Key) 5001K-ND |
| 18 | JP2, JP3 | 2 | Open | 3 possible | | |
| 19 | JP1, JP4 | 2 | Header, 0.1" CTRS, 0.025" sq. pins | 3 possible | (Sullins) PBC36SAAN | (Digi-Key) S1011E-36-ND |
| 20 | JP1, JP4 | 2 | Shunts | | (Sullins) SSC02SYAN | (Digi-Key) S9002-ND |
| 21 | U1 | 1 | IC, THS7374 | PW | (TI) THS7374IPW | |
| 22 | | 4 | Standoff, 4-40 HEX, 0.625" length | | (Keystone) 1808 | (Digi-Key) 1808K-ND |
| 23 | | 4 | Screw, Phillips, 4-40, 0.250" | | (BF) PMS 440 0031 PH | (Digi-Key) H343-ND |
| 24 | | 1 | Printed Circuit Board | | (TI) Edge# 6497066 Rev. B | |

EVALUATION BOARD/KIT IMPORTANT NOTICE

Texas Instruments (TI) provides the enclosed product(s) under the following conditions:

This evaluation board/kit is intended for use for **ENGINEERING DEVELOPMENT, DEMONSTRATION, OR EVALUATION PURPOSES ONLY** and is not considered by TI to be a finished end-product fit for general consumer use. Persons handling the product(s) must have electronics training and observe good engineering practice standards. As such, the goods being provided are not intended to be complete in terms of required design-, marketing-, and/or manufacturing-related protective considerations, including product safety and environmental measures typically found in end products that incorporate such semiconductor components or circuit boards. This evaluation board/kit does not fall within the scope of the European Union directives regarding electromagnetic compatibility, restricted substances (RoHS), recycling (WEEE), FCC, CE or UL, and therefore may not meet the technical requirements of these directives or other related directives.

Should this evaluation board/kit not meet the specifications indicated in the User's Guide, the board/kit may be returned within 30 days from the date of delivery for a full refund. **THE FOREGOING WARRANTY IS THE EXCLUSIVE WARRANTY MADE BY SELLER TO BUYER AND IS IN LIEU OF ALL OTHER WARRANTIES, EXPRESSED, IMPLIED, OR STATUTORY, INCLUDING ANY WARRANTY OF MERCHANTABILITY OR FITNESS FOR ANY PARTICULAR PURPOSE.**

The user assumes all responsibility and liability for proper and safe handling of the goods. Further, the user indemnifies TI from all claims arising from the handling or use of the goods. Due to the open construction of the product, it is the user's responsibility to take any and all appropriate precautions with regard to electrostatic discharge.

EXCEPT TO THE EXTENT OF THE INDEMNITY SET FORTH ABOVE, NEITHER PARTY SHALL BE LIABLE TO THE OTHER FOR ANY INDIRECT, SPECIAL, INCIDENTAL, OR CONSEQUENTIAL DAMAGES.

TI currently deals with a variety of customers for products, and therefore our arrangement with the user **is not exclusive**.

TI assumes **no liability for applications assistance, customer product design, software performance, or infringement of patents or services described herein**.

Please read the User's Guide and, specifically, the Warnings and Restrictions notice in the User's Guide prior to handling the product. This notice contains important safety information about temperatures and voltages. For additional information on TI's environmental and/or safety programs, please contact the TI application engineer or visit www.ti.com/esh.

No license is granted under any patent right or other intellectual property right of TI covering or relating to any machine, process, or combination in which such TI products or services might be or are used.

FCC Warning

This evaluation board/kit is intended for use for **ENGINEERING DEVELOPMENT, DEMONSTRATION, OR EVALUATION PURPOSES ONLY** and is not considered by TI to be a finished end-product fit for general consumer use. It generates, uses, and can radiate radio frequency energy and has not been tested for compliance with the limits of computing devices pursuant to part 15 of FCC rules, which are designed to provide reasonable protection against radio frequency interference. Operation of this equipment in other environments may cause interference with radio communications, in which case the user at his own expense will be required to take whatever measures may be required to correct this interference.

EVM WARNINGS AND RESTRICTIONS

It is important to operate this EVM within the input voltage range of 2.85 V to 5.5 V single supply and the output voltage range of 0 V to 5.5 V.

Exceeding the specified input range may cause unexpected operation and/or irreversible damage to the EVM. If there are questions concerning the input range, please contact a TI field representative prior to connecting the input power.

Applying loads outside of the specified output range may result in unintended operation and/or possible permanent damage to the EVM. Please consult the EVM User's Guide prior to connecting any load to the EVM output. If there is uncertainty as to the load specification, please contact a TI field representative.

During normal operation, some circuit components may have case temperatures greater than +85°C. The EVM is designed to operate properly with certain components above +85°C as long as the input and output ranges are maintained. These components include but are not limited to linear regulators, switching transistors, pass transistors, and current sense resistors. These types of devices can be identified using the EVM schematic located in the EVM User's Guide. When placing measurement probes near these devices during operation, please be aware that these devices may be very warm to the touch.

Mailing Address: Texas Instruments, Post Office Box 655303, Dallas, Texas 75265

Copyright © 2009, Texas Instruments Incorporated

REVISION HISTORY

NOTE: Page numbers for previous revisions may differ from page numbers in the current version.

| Changes from Revision A (January 2010) to Revision B | Page |
|---|-------------|
| • Deleted <i>Lead temperature</i> parameter from Absolute Maximum Ratings table | 2 |
| • Added <i>ESD ratings</i> to Absolute Maximum Ratings table | 2 |

| Changes from Original (July 2008) to Revision A | Page |
|---|-------------|
| • Added Figure 9 , Figure 10 , Figure 11 to the Typical Characteristics: General | 9 |
| • Added Figure 25 , Figure 26 , Figure 27 , Figure 28 , Figure 29 , Figure 30 , Figure 31 , Figure 32 , Figure 33 to the Typical Characteristics: $V_{S+} = 3.3\text{ V}$ | 11 |
| • Added Figure 47 , Figure 48 , Figure 49 , Figure 50 , Figure 51 , Figure 52 , Figure 53 , Figure 54 , Figure 55 to the Typical Characteristics: $V_{S+} = 5\text{ V}$ | 15 |

PACKAGING INFORMATION

| Orderable Device | Status (1) | Package Type | Package Drawing | Pins | Package Qty | Eco Plan (2) | Lead/Ball Finish (6) | MSL Peak Temp (3) | Op Temp (°C) | Device Marking (4/5) | Samples |
|------------------|---------------|--------------|-----------------|------|-------------|-------------------------|-------------------------|----------------------|--------------|-------------------------|-------------------------|
| THS7374IPW | ACTIVE | TSSOP | PW | 14 | 90 | Green (RoHS & no Sb/Br) | CU NIPDAU | Level-2-260C-1 YEAR | -40 to 85 | THS7374 | Samples |
| THS7374IPWR | ACTIVE | TSSOP | PW | 14 | 2000 | Green (RoHS & no Sb/Br) | CU NIPDAU | Level-2-260C-1 YEAR | -40 to 85 | THS7374 | Samples |

(1) The marketing status values are defined as follows:

ACTIVE: Product device recommended for new designs.

LIFEBUY: TI has announced that the device will be discontinued, and a lifetime-buy period is in effect.

NRND: Not recommended for new designs. Device is in production to support existing customers, but TI does not recommend using this part in a new design.

PREVIEW: Device has been announced but is not in production. Samples may or may not be available.

OBSOLETE: TI has discontinued the production of the device.

(2) **RoHS:** TI defines "RoHS" to mean semiconductor products that are compliant with the current EU RoHS requirements for all 10 RoHS substances, including the requirement that RoHS substance do not exceed 0.1% by weight in homogeneous materials. Where designed to be soldered at high temperatures, "RoHS" products are suitable for use in specified lead-free processes. TI may reference these types of products as "Pb-Free".

RoHS Exempt: TI defines "RoHS Exempt" to mean products that contain lead but are compliant with EU RoHS pursuant to a specific EU RoHS exemption.

Green: TI defines "Green" to mean the content of Chlorine (Cl) and Bromine (Br) based flame retardants meet JS709B low halogen requirements of <=1000ppm threshold. Antimony trioxide based flame retardants must also meet the <=1000ppm threshold requirement.

(3) MSL, Peak Temp. - The Moisture Sensitivity Level rating according to the JEDEC industry standard classifications, and peak solder temperature.

(4) There may be additional marking, which relates to the logo, the lot trace code information, or the environmental category on the device.

(5) Multiple Device Markings will be inside parentheses. Only one Device Marking contained in parentheses and separated by a "-" will appear on a device. If a line is indented then it is a continuation of the previous line and the two combined represent the entire Device Marking for that device.

(6) Lead/Ball Finish - Orderable Devices may have multiple material finish options. Finish options are separated by a vertical ruled line. Lead/Ball Finish values may wrap to two lines if the finish value exceeds the maximum column width.

Important Information and Disclaimer:The information provided on this page represents TI's knowledge and belief as of the date that it is provided. TI bases its knowledge and belief on information provided by third parties, and makes no representation or warranty as to the accuracy of such information. Efforts are underway to better integrate information from third parties. TI has taken and continues to take reasonable steps to provide representative and accurate information but may not have conducted destructive testing or chemical analysis on incoming materials and chemicals. TI and TI suppliers consider certain information to be proprietary, and thus CAS numbers and other limited information may not be available for release.

In no event shall TI's liability arising out of such information exceed the total purchase price of the TI part(s) at issue in this document sold by TI to Customer on an annual basis.

TAPE AND REEL INFORMATION



QUADRANT ASSIGNMENTS FOR PIN 1 ORIENTATION IN TAPE



*All dimensions are nominal

| Device | Package Type | Package Drawing | Pins | SPQ | Reel Diameter (mm) | Reel Width W1 (mm) | A0 (mm) | B0 (mm) | K0 (mm) | P1 (mm) | W (mm) | Pin1 Quadrant |
|-------------|--------------|-----------------|------|------|--------------------|--------------------|---------|---------|---------|---------|--------|---------------|
| THS7374IPWR | TSSOP | PW | 14 | 2000 | 330.0 | 12.4 | 6.9 | 5.6 | 1.6 | 8.0 | 12.0 | Q1 |

TAPE AND REEL BOX DIMENSIONS



*All dimensions are nominal

| Device | Package Type | Package Drawing | Pins | SPQ | Length (mm) | Width (mm) | Height (mm) |
|-------------|--------------|-----------------|------|------|-------------|------------|-------------|
| THS7374IPWR | TSSOP | PW | 14 | 2000 | 367.0 | 367.0 | 35.0 |

PW (R-PDSO-G14)

PLASTIC SMALL OUTLINE



4211284-2/G 08/15

- NOTES:
- A. All linear dimensions are in millimeters.
 - B. This drawing is subject to change without notice.
 - C. Publication IPC-7351 is recommended for alternate designs.
 - D. Laser cutting apertures with trapezoidal walls and also rounding corners will offer better paste release. Customers should contact their board assembly site for stencil design recommendations. Refer to IPC-7525 for other stencil recommendations.
 - E. Customers should contact their board fabrication site for solder mask tolerances between and around signal pads.

IMPORTANT NOTICE AND DISCLAIMER

TI PROVIDES TECHNICAL AND RELIABILITY DATA (INCLUDING DATASHEETS), DESIGN RESOURCES (INCLUDING REFERENCE DESIGNS), APPLICATION OR OTHER DESIGN ADVICE, WEB TOOLS, SAFETY INFORMATION, AND OTHER RESOURCES "AS IS" AND WITH ALL FAULTS, AND DISCLAIMS ALL WARRANTIES, EXPRESS AND IMPLIED, INCLUDING WITHOUT LIMITATION ANY IMPLIED WARRANTIES OF MERCHANTABILITY, FITNESS FOR A PARTICULAR PURPOSE OR NON-INFRINGEMENT OF THIRD PARTY INTELLECTUAL PROPERTY RIGHTS.

These resources are intended for skilled developers designing with TI products. You are solely responsible for (1) selecting the appropriate TI products for your application, (2) designing, validating and testing your application, and (3) ensuring your application meets applicable standards, and any other safety, security, or other requirements. These resources are subject to change without notice. TI grants you permission to use these resources only for development of an application that uses the TI products described in the resource. Other reproduction and display of these resources is prohibited. No license is granted to any other TI intellectual property right or to any third party intellectual property right. TI disclaims responsibility for, and you will fully indemnify TI and its representatives against, any claims, damages, costs, losses, and liabilities arising out of your use of these resources.

TI's products are provided subject to TI's Terms of Sale (www.ti.com/legal/termsofsale.html) or other applicable terms available either on ti.com or provided in conjunction with such TI products. TI's provision of these resources does not expand or otherwise alter TI's applicable warranties or warranty disclaimers for TI products.

Mailing Address: Texas Instruments, Post Office Box 655303, Dallas, Texas 75265
Copyright © 2019, Texas Instruments Incorporated

Looking for pricing, stock, or lifecycle information?

Click below to explore more details on WIN SOURCE:

 [View THS7374IPWR on WIN SOURCE](#)

 [Texas Instruments](#) Information

Optimize Your Supply Chain with WIN SOURCE Solutions

-  Global Sourcing Solution
-  Obsolete Management
-  Cost Control Management
-  Shortage Management
-  Alternative Solution
-  Excess Inventory Management