



# THE DATASHEET OF TFP410PAP



# TFP410 TI PanelBus™ Digital Transmitter

## 1 Features

- Digital visual interface (DVI) compliant<sup>1</sup>
- Supports pixel rates up to 165MHz (including 1080p and WUXGA at 60Hz)
- Universal graphics controller interface:
  - 12-bit, dual-edge and 24-bit, single-edge input modes
  - Adjustable 1.1V to 1.8V and standard 3.3V CMOS input signal Levels
  - Fully differential and single-ended input clocking modes
  - Standard Intel 12-bit digital video port compatible as on Intel™ 81x Chipsets
- Enhanced PLL noise immunity:
  - On-chip regulators and bypass capacitors for reducing system Costs
- Enhanced jitter performance:
  - No HSYNC jitter anomaly
  - Negligible data-dependent jitter
- Programmable using I<sup>2</sup>C serial interface
- Monitor detection through hot-plug and receiver detection
- Single 3.3V supply operation
- 64-Pin TQFP using TI's PowerPAD™ package
- TI's advanced 0.18μm EPIC-5™ CMOS process technology
- Pin compatible with Si164 DVI transmitter<sup>1</sup>

## 2 Applications

- [DVD](#)
- [Blu-ray™](#)
- [HD projectors](#)
- [DVI/HDMI transmitter](#)<sup>2</sup>

## 3 Description

The TFP410 device is a Texas Instruments PanelBus™ flat-panel display product, part of a comprehensive family of end-to-end DVI 1.0-compliant solutions, targeted at the PC and consumer electronics industry.

The TFP410 device provides a universal interface to allow a glueless connection to most commonly available graphics controllers. Some of the advantages of this universal interface include selectable bus widths, adjustable signal levels, and differential and single-ended clocking. The adjustable 1.1V to 1.8V digital interface provides a low-EMI, high-speed bus that connects seamlessly with 12-bit or 24-bit interfaces. The DVI interface supports flat-panel display resolutions up to UXGA at 165MHz in 24-bit true color pixel format.

The TFP410 device combines PanelBus circuit innovation with TI's advanced 0.18μm EPIC-5 CMOS process technology and TI's ultra-low ground inductance PowerPAD package. The result is a compact 64-pin TQFP package providing a reliable, low-current, low-noise, high-speed digital interface solution.

### Package Information

PART NUMBER	PACKAGE <sup>(1)</sup>	PACKAGE SIZE <sup>(2)</sup>
TFP410	PAP (HTQFP, 64)	12mm × 12mm

(1) For more information, see [Section 10](#)

(2) The package size (length × width) is a nominal value and includes pins, where applicable.

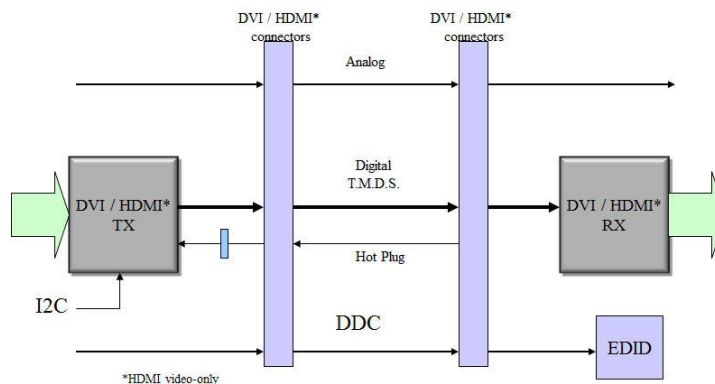

**Typical HDMI Interface**

<sup>1</sup> The digital visual interface (DVI) specification is an industry standard developed by the digital display working group (DDWG) for high-speed digital connection to digital displays and has been adopted by industry-leading PC and consumer electronics manufacturers. The TFP410 is compliant to the DVI Revision 1.0 specification.

<sup>2</sup> HDMI video-only



## Table of Contents

<b>1 Features</b> .....	1	6.5 Programming.....	17
<b>2 Applications</b> .....	1	6.6 Register Maps.....	18
<b>3 Description</b> .....	1	<b>7 Application and Implementation</b> .....	25
<b>4 Pin Configuration and Functions</b> .....	2	7.1 Application Information.....	25
<b>5 Specifications</b> .....	6	7.2 Typical Application.....	25
5.1 Absolute Maximum Ratings.....	6	7.3 Power Supply Recommendations.....	28
5.2 ESD Ratings.....	6	7.4 Layout.....	28
5.3 Recommended Operating Conditions.....	6	<b>8 Device and Documentation Support</b> .....	33
5.4 Thermal Information.....	6	8.1 Receiving Notification of Documentation Updates....	33
5.5 Electrical Characteristics.....	7	8.2 Support Resources.....	33
5.6 Timing Requirements.....	7	8.3 Trademarks.....	33
5.7 Typical Characteristics.....	9	8.4 Electrostatic Discharge Caution.....	33
<b>6 Detailed Description</b> .....	10	8.5 Glossary.....	33
6.1 Overview.....	10	<b>9 Revision History</b> .....	33
6.2 Functional Block Diagram.....	11	<b>10 Mechanical, Packaging, and Orderable Information</b> .....	34
6.3 Feature Description.....	11		
6.4 Device Functional Modes.....	12		

## 4 Pin Configuration and Functions

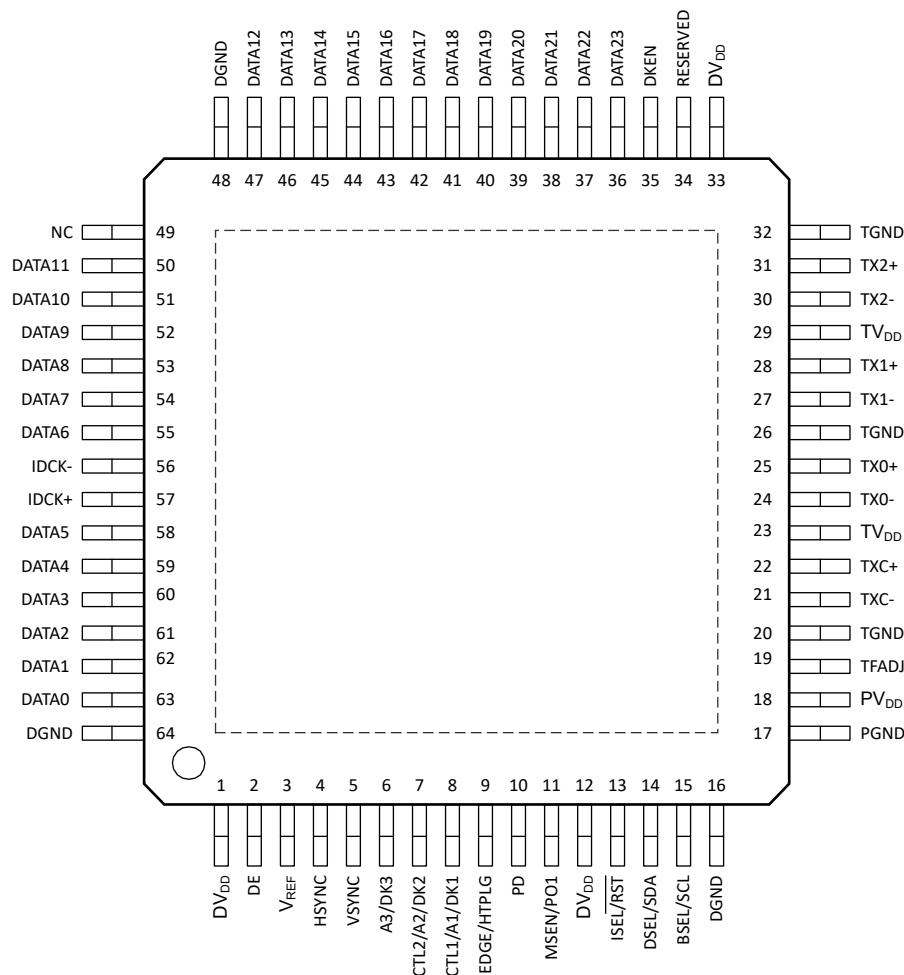

Figure 4-1. PAP Package, 64 Pin HTQFP (Top View)

**Table 4-1. Pin Functions**

PIN		TYPE <sup>(1)</sup>	DESCRIPTION
NAME	NO.		
<b>INPUT</b>			
DATA[23:12]	36–47	I	The upper 12 bits of the 24-bit pixel bus In 24-bit, single-edge input mode (BSEL = high), this bus inputs the top half of the 24-bit pixel bus. In 12-bit, dual-edge input mode (BSEL = low), these bits are not used to input pixel data. In this mode, the state of DATA[23:16] is input to the I <sup>2</sup> C register CFG. This allows 8 bits of user configuration data to be read by the graphics controller through the I <sup>2</sup> C interface (see <a href="#">Section 6.6</a> ). Note: All unused data inputs should be tied to GND or V <sub>DD</sub> .
DATA[11:0]	50–55, 58–63	I	The lower 12 bits of the 24-bit pixel bus/12-bit pixel bus input In 24-bit, single-edge input mode (BSEL = high), this bus inputs the bottom half of the 24-bit pixel bus. In 12-bit, dual-edge input mode (BSEL = low), this bus inputs 1/2 a pixel (12 bits) at every latch edge (both rising and falling) of the clock.
IDCK– IDCK+	56 57	I	Differential clock input. The TFP410 supports both single-ended and fully differential clock input modes. In the single-ended clock input mode, the IDCK+ input (pin 57) should be connected to the single-ended clock source and the IDCK– input (pin 56) should be tied to GND. In the differential clock input mode, the TFP410 uses the crossover point between the IDCK+ and IDCK– signals as the timing reference for latching incoming data DATA[23:0], DE, HSYNC, and VSYNC. The differential clock input mode is only available in the low signal swing mode.
DE	2	I	Data enable. As defined in DVI 1.0 specification, the DE signal allows the transmitter to encode pixel data or control data on any given input clock cycle. During active video (DE = high), the transmitter encodes pixel data, DATA[23:0]. During the blanking interval (DE = low), the transmitter encodes HSYNC, VSYNC and CTL[3:1].
HSYNC	4	I	Horizontal sync input
VSYNC	5	I	Vertical sync input
A3/DK3 CTL2/A2/DK2 CTL1/A1/DK1	6 7 8	I	The operation of these three multifunction inputs depends on the settings of the ISEL (pin 13) and DKEN (pin 35) inputs. All three inputs support 3.3V CMOS signal levels and contain weak pulldown resistors so that if left unconnected they default to all low. When the I <sup>2</sup> C bus is disabled (ISEL = low) and the de-skew mode is disabled (DKEN = low), pins 7 and 8 become the control inputs, CTL[2:1], which can be used to send additional information across the DVI link during the blanking interval (DE = low). Pin 6 is not used. When the I <sup>2</sup> C bus is disabled (ISEL = low) and the de-skew mode is enabled (DKEN = high), these three inputs become the de-skew inputs DK[3:1], used to adjust the setup and hold times of the pixel data inputs DATA[23:0], relative to the clock input IDCK±. When the I <sup>2</sup> C bus is enabled (ISEL = high), these three inputs become the 3 LSBs of the I <sup>2</sup> C target address, A[3:1].
<b>CONFIGURATION/PROGRAMMING</b>			
MSEN/PO1	11	O	Monitor sense/programmable output 1. The operation of this pin depends on whether the I <sup>2</sup> C interface is enabled or disabled. This pin has an open-drain output and is only 3.3V tolerant. An external 5kΩ pullup resistor connected to V <sub>DD</sub> is required on this pin. When I <sup>2</sup> C is disabled (ISEL = low), a high level indicates a powered on receiver is detected at the differential outputs. A low level indicates a powered on receiver is not detected. This function is only valid in dc-coupled systems. When I <sup>2</sup> C is enabled (ISEL = high), this output is programmable through the I <sup>2</sup> C interface (see the I <sup>2</sup> C register descriptions section).
ISEL/ $\overline{\text{RST}}$	13	I	I <sup>2</sup> C interface select/I <sup>2</sup> C RESET (active low, asynchronous) If ISEL is high, then the I <sup>2</sup> C interface is active. Default values for the I <sup>2</sup> C registers can be found in the see <a href="#">Section 6.6</a> . If ISEL is low, then I <sup>2</sup> C is disabled and the chip configuration is specified by the configuration pins (BSEL, DSEL, EDGE, VREF) and state pins (PD, DKEN). If ISEL is brought low and then back high, the I <sup>2</sup> C state machine is reset. The register values are changed to their default values and are not preserved from before the reset.

**Table 4-1. Pin Functions (continued)**

PIN		TYPE <sup>(1)</sup>	DESCRIPTION
NAME	NO.		
BSEL/SCL	15	I	Input bus select/I <sup>2</sup> C clock input. The operation of this pin depends on whether the I <sup>2</sup> C interface is enabled or disabled. This pin is only 3.3V tolerant. When I <sup>2</sup> C is disabled (ISEL = low), a high level selects 24-bit input, single-edge input mode. A low level selects 12-bit input, dual-edge input mode. When I <sup>2</sup> C is enabled (ISEL = high), this pin functions as the I <sup>2</sup> C clock input (see <a href="#">Section 6.6</a> ). In this configuration, this pin has an open-drain output that requires an external 5kΩ pullup resistor connected to V <sub>DD</sub> .
DSEL/SDA	14	I/O	DSEL/I <sup>2</sup> C data. The operation of this pin depends on whether the I <sup>2</sup> C interface is enabled or disabled. This pin is only 3.3V tolerant. When I <sup>2</sup> C is disabled (ISEL = low), this pin is used with BSEL and V <sub>REF</sub> to select the single-ended or differential input clock mode (see <a href="#">Table 6-1</a> ). When I <sup>2</sup> C is enabled (ISEL = high), this pin functions as the I <sup>2</sup> C bidirectional data line. In this configuration, this pin has an open-drain output that requires an external 5kΩ pullup resistor connected to V <sub>DD</sub> .
EDGE/HTPLG	9	I	Edge select/hot plug input. The operation of this pin depends on whether the I <sup>2</sup> C interface is enabled or disabled. This input is 3.3V tolerant only. When I <sup>2</sup> C is disabled (ISEL = low), a high level selects the primary latch to occur on the rising edge of the input clock IDCK+. A low level selects the primary latch to occur on the falling edge of the input clock IDCK+. This is the case for both single-ended and differential input clock modes. When I <sup>2</sup> C is enabled (ISEL = high), this pin is used to monitor the hot plug detect signal. When used for <i>hot-plug</i> detection, this pin requires a series 1kΩ resistor.
DKEN	35	I	Data de-skew enable. The de-skew function can be enabled either through I <sup>2</sup> C or by this pin when I <sup>2</sup> C is disabled. When de-skew is enabled, the input clock to data setup/hold time can be adjusted in discrete trim increments. The amount of trim per increment is defined by t <sub>(STEP)</sub> . When I <sup>2</sup> C is disabled (ISEL = low), a high level enables de-skew with the trim increment determined by pins DK[3:1] (see <a href="#">Section 6.4.2</a> ). A low level disables de-skew and the default trim setting is used. When I <sup>2</sup> C is enabled (ISEL = high), the value of DKEN and the trim increment are selected through I <sup>2</sup> C. In this configuration, the DKEN pin should be tied to either GND or V <sub>DD</sub> to avoid a floating input.
V <sub>REF</sub>	3	I	Input reference voltage. Selects the swing range of the digital data inputs (DATA[23:0], DE, HSYNC, VSYNC, and IDCK±). For high-swing 3.3V input signal levels, V <sub>REF</sub> should be tied to V <sub>DD</sub> . For low-swing input signal levels, V <sub>REF</sub> should be set to half of the maximum input voltage level. See <a href="#">Section 5.3</a> for the allowable range for V <sub>REF</sub> . The desired V <sub>REF</sub> voltage level is typically derived using a simple voltage-divider circuit.
$\overline{\text{PD}}$	10	I	Power down (active low). In the powerdown state, only the digital I/O buffers and I <sup>2</sup> C interface remain active. When I <sup>2</sup> C is disabled (ISEL = low), a high level selects the normal operating mode. A low level selects the powerdown mode. When I <sup>2</sup> C is enabled (ISEL = high), the power-down state is selected through I <sup>2</sup> C. In this configuration, the $\overline{\text{PD}}$ pin should be tied to GND. Note: The default register value for $\overline{\text{PD}}$ is low, so the device is in powerdown mode when I <sup>2</sup> C is first enabled or after an I <sup>2</sup> C RESET.
<b>RESERVED</b>			
RESERVED	34	I	This pin is reserved and must be tied to GND for normal operation.
<b>DVI DIFFERENTIAL SIGNAL OUTPUT PINS</b>			
TX0+ TX0-	25 24	○	Channel 0 DVI differential output pair. TX0± transmits the 8-bit blue pixel data during active video and HSYNC and VSYNC during the blanking interval.
TX1+ TX1-	28 27	○	Channel 1 DVI differential output pair. TX1± transmits the 8-bit green pixel data during active video and CTL[1] during the blanking interval.
TX2+ TX2-	31 30	○	Channel 2 DVI differential output pair. TX2± transmits the 8-bit red pixel data during active video and CTL[3:2] during the blanking interval.

**Table 4-1. Pin Functions (continued)**

PIN		TYPE <sup>(1)</sup>	DESCRIPTION
NAME	NO.		
TXC+ TXC-	22 21	O	DVI differential output clock.
TFADJ	19	I	Full-scale adjust. This pin controls the amplitude of the DVI output voltage swing, determined by the value of the pullup resistor $R_{TFADJ}$ connected to $TV_{DD}$ .
<b>POWER AND GROUND PINS</b>			
DV <sub>DD</sub>	1, 12, 33	Power	Digital power supply. Must be set to 3.3V nominal.
PV <sub>DD</sub>	18	Power	PLL power supply. Must be set to 3.3V nominal.
TV <sub>DD</sub>	23, 29	Power	Transmitter differential output driver power supply. Must be set to 3.3V nominal.
DGND	16, 48, 64	Ground	Digital ground
PGND	17	Ground	PLL ground
TGND	20, 26, 32	Ground	Transmitter differential output driver ground
NC	49	NC	No connection required. If connected, tie high.

(1) I = input, O = output, NC = no connection, P = power, G = ground

## 5 Specifications

### 5.1 Absolute Maximum Ratings

over operating free-air temperature range (unless otherwise noted)<sup>(1)</sup>

		MIN	MAX	UNIT
DV <sub>DD</sub> , PV <sub>DD</sub> , TV <sub>DD</sub>	Supply voltage range	-0.5	4	V
	Input voltage, logic/analog signals	-0.5	4	V
R <sub>T</sub>	External DVI single-ended termination resistance	0 to open circuit		Ω
	External TFADJ resistance, RTFADJ	300 to open circuit		Ω
	Case temperature for 10 seconds	260		°C
	JEDEC latch-up (EIA/JESD78)	100		mA
T <sub>stg</sub>	Storage temperature	260		°C

- (1) Stresses beyond those listed under *Absolute Maximum Ratings* may cause permanent damage to the device. These are stress ratings only, which do not imply functional operation of the device at these or any other conditions beyond those indicated under *Recommended Operating Conditions*. Exposure to absolute-maximum-rated conditions for extended periods may affect device reliability.

### 5.2 ESD Ratings

			VALUE	UNIT
V <sub>(ESD)</sub>	Electrostatic discharge	Human body model (HBM), per ANSI/ESDA/JEDEC JS-001 <sup>(1)</sup>	DVI pins ±4000 All other pins ±2000	V

- (1) JEDEC document JEP155 states that 500-V HBM allows safe manufacturing with a standard ESD control process.

### 5.3 Recommended Operating Conditions

over operating free-air temperature range (unless otherwise noted)

			MIN	NOM	MAX	UNIT
V <sub>DD</sub>	Supply voltage (DV <sub>DD</sub> , PV <sub>DD</sub> , TV <sub>DD</sub> )		3.0	3.3	3.6	V
V <sub>REF</sub>	Input reference voltage	Low-swing mode	0.55	V <sub>DDQ</sub> /2 <sup>(1)</sup>	0.9	V
		High-swing mode			DV <sub>DD</sub>	V
AV <sub>DD</sub>	DVI termination supply voltage <sup>(2)</sup>	DVI receiver	3.14	3.3	3.46	V
R <sub>T</sub>	DVI Single-ended termination resistance <sup>(3)</sup>	DVI receiver	45	50	55	Ω
R <sub>(TFADJ)</sub>	TFADJ resistor for DVI-compliant V <sub>(SWING)</sub> range	400mV = V <sub>(SWING)</sub> = 600mV	505	510	515	Ω
T <sub>A</sub>	Operating free-air temperature range		0	25	70	°C

- (1) V<sub>DDQ</sub> defines the maximum low-level input voltage, it is not an actual input voltage.  
(2) AV<sub>DD</sub> is the termination supply voltage of the DVI link.  
(3) R<sub>T</sub> is the single-ended termination resistance at the receiver end of the DVI link.

### 5.4 Thermal Information

THERMAL METRIC <sup>(1)</sup>		TFP410	UNIT
		PAP	
		64 PINS	
R <sub>θJA</sub>	Junction-to-ambient thermal resistance	26.6	°C/W
R <sub>θJC(top)</sub>	Junction-to-case (top) thermal resistance	14.1	
R <sub>θJB</sub>	Junction-to-board thermal resistance	11.3	
ψ <sub>JT</sub>	Junction-to-top characterization parameter	0.4	
ψ <sub>JB</sub>	Junction-to-board characterization parameter	11.2	
R <sub>θJC(bot)</sub>	Junction-to-case (bottom) thermal resistance	0.9	

- (1) For more information about traditional and new thermal metrics, *IC Package Thermal Metrics* application report (SPRA953).

## 5.5 Electrical Characteristics

over recommended operating free-air temperature range (unless otherwise noted)

PARAMETER		TEST CONDITIONS	MIN	TYP	MAX	UNIT	
<b>DC SPECIFICATIONS</b>							
V <sub>IH</sub>	High-level input voltage (Data, DE, VSYNC, HSYNC, and IDCK+/- CMOS inputs)	V <sub>REF</sub> = DV <sub>DD</sub>	0.7V <sub>DD</sub>			V	
		0.5V ≤ V ≤ 0.95V	V <sub>REF</sub> + 0.2				
	High-level input voltage (all other CMOS inputs)	0.7V <sub>DD</sub>					
V <sub>IL</sub>	Low-level input voltage (Data, DE, VSYNC, HSYNC, and IDCK+/- CMOS inputs)	V <sub>REF</sub> = DV <sub>DD</sub>	0.3V <sub>DD</sub>			V	
		0.5V ≤ V ≤ 0.95V	V <sub>REF</sub> - 0.2				
	Low-level input voltage (all other CMOS inputs)	0.3V <sub>DD</sub>					
V <sub>OH</sub>	High-level digital output voltage (open-drain output)	V <sub>DD</sub> = 3V, I <sub>OH</sub> = 20μA	2.4			V	
V <sub>OL</sub>	Low-level digital output voltage (open-drain output)	V <sub>DD</sub> = 3.6V, I <sub>OL</sub> = 4mA			0.4	V	
I <sub>IH</sub>	High-level input current	V <sub>I</sub> = 3.6V			±25	μA	
I <sub>IL</sub>	Low-level input current	V <sub>I</sub> = 0			±25	μA	
V <sub>H</sub>	DVI single-ended high-level output voltage	AV <sub>DD</sub> = 3.3V ± 5%, R <sub>T</sub> <sup>(1)</sup> = 50Ω ± 10%, R <sub>TFADJ</sub> = 510Ω ± 1%	AV <sub>DD</sub> - 0.01	AV <sub>DD</sub> + 0.01		V	
V <sub>L</sub>	DVI single-ended low-level output voltage		AV <sub>DD</sub> - 0.6		AV <sub>DD</sub> - 0.4	V	
V <sub>SWING</sub>	DVI single-ended output swing voltage		400		600	mV <sub>P-P</sub>	
V <sub>OFF</sub>	DVI single-ended standby/off output voltage		AV <sub>DD</sub> - 0.01		AV <sub>DD</sub> + 0.01	V	
I <sub>PD</sub>	Power-down current <sup>(3)</sup>				200	500	μA
I <sub>IDD</sub>	Normal power supply current	Worst-case pattern <sup>(2)</sup>			200	250	mA
<b>AC SPECIFICATIONS</b>							
f <sub>(IDCK)</sub>	IDCK frequency		25			165	MHz
t <sub>r</sub>	DVI output rise time (20-80%) <sup>(4)</sup>	f <sub>(IDCK)</sub> = 165MHz	75			240	ps
t <sub>f</sub>	DVI output fall time (20-80%) <sup>(4)</sup>		75			240	ps
t <sub>sk(D)</sub>	DVI output intra-pair + to - differential skew <sup>(5)</sup> , see Figure 5-4		50				ps
t <sub>ojit</sub>	DVI output clock jitter, max. <sup>(6)</sup>				150		ps
t <sub>(STEP)</sub>	De-skew trim increment		DKEN = 1		350		ps

- (1) R<sub>T</sub> is the single-ended termination resistance at the receiver end of the DVI link
- (2) Black and white checkerboard pattern, each checker is one pixel wide.
- (3) Assumes all inputs to the transmitter are not toggling.
- (4) Rise and fall times are measured as the time between 20% and 80% of signal amplitude.
- (5) Measured differentially at the 50% crossing point using the IDCK+ input clock as a trigger.
- (6) Relative to input clock (IDCK).

## 5.6 Timing Requirements

		MIN	NOM	MAX	UNIT
t <sub>(pixel)</sub>	Pixel time period <sup>(1)</sup>	6.06		40	ns
t <sub>(IDCK)</sub>	IDCK duty cycle	30%		70%	
t <sub>(jitt)</sub>	IDCK clock jitter tolerance		2		ns
t <sub>sk(CC)</sub>	DVI output inter-pair or channel-to-channel skew <sup>(2)</sup> , see Figure 5-2	f <sub>(IDCK)</sub> = 165MHz		1.2	ns
t <sub>su(IDF)</sub>	Data, DE, VSYNC, HSYNC setup time to IDCK+ falling edge, see Figure 5-2	Single edge (BSEL=1, DSEL=0, DKEN=0, EDGE=0)		1.2	ns
t <sub>h(IDF)</sub>	Data, DE, VSYNC, HSYNC hold time to IDCK+ falling edge, see Figure 5-2			1.3	ns
t <sub>su(IDR)</sub>	Data, DE, VSYNC, HSYNC setup time to IDCK+ rising edge, see Figure 5-2	Single edge (BSEL=1, DSEL=0, DKEN=0, EDGE=1)		1.2	ns
t <sub>h(IDR)</sub>	Data, DE, VSYNC, HSYNC hold time to IDCK+ rising edge, see Figure 5-2			1.3	ns

## 5.6 Timing Requirements (continued)

		MIN	NOM	MAX	UNIT
$t_{su(ID)}$	Data, DE, VSYNC, HSYNC setup time to IDCK+ falling/rising edge, see <a href="#">Figure 5-3</a>		0.9		ns
$t_{h(ID)}$	Data, DE, VSYNC, HSYNC hold time to IDCK+ falling/rising edge, see <a href="#">Figure 5-3</a>		1		ns

- (1)  $t_{(pixel)}$  is the pixel time defined as the period of the TXC output clock. The period of IDCK is equal to  $t_{(pixel)}$ .  
 (2) Measured differentially at the 50% crossing point using the IDCK+ input clock as a trigger.

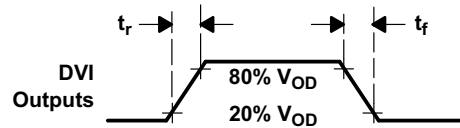

Figure 5-1. Rise and Fall Time for DVI Outputs

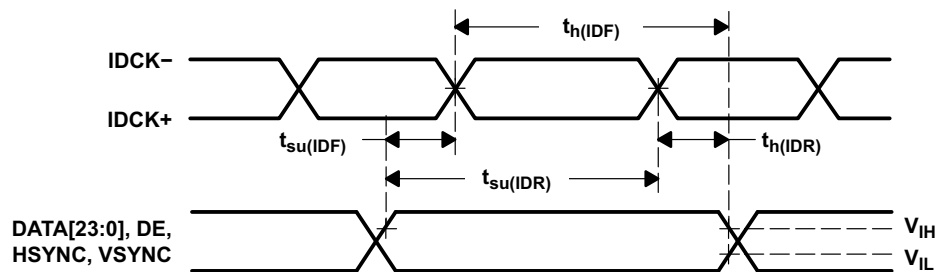

Figure 5-2. Control and Single-Edge-Data Setup/Hold Time to IDCK±

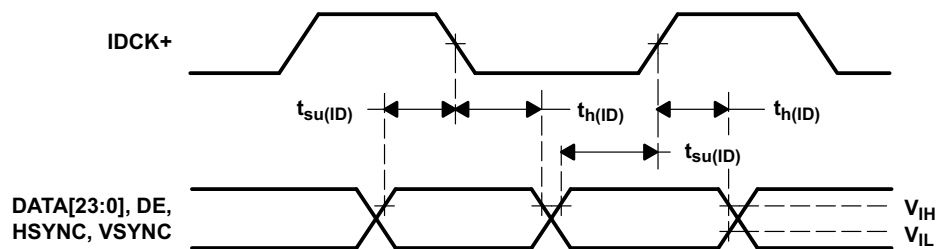

Figure 5-3. Dual Edge Data Setup/Hold Times to IDCK+

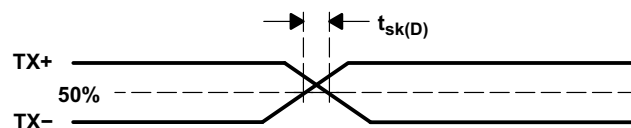

Figure 5-4. Analog Output Intra-Pair ± Differential Skew

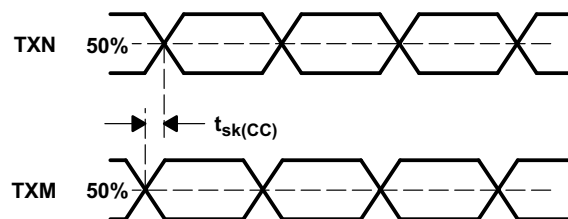

Figure 5-5. Analog Output Channel-to-Channel Skew

### 5.7 Typical Characteristics

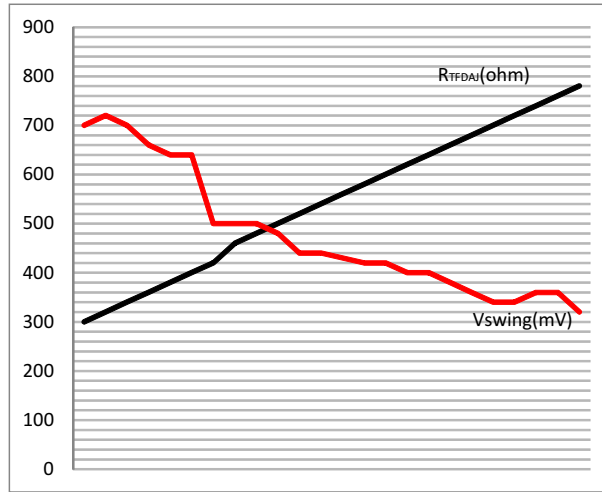

Figure 5-6.  $R_{TFDAJ}$  vs  $V_{swing}$

## 6 Detailed Description

### 6.1 Overview

The TFP410 is a DVI-compliant digital transmitter that is used in digital host monitor systems to T.M.D.S. encode and serialize RGB pixel data streams. TFP410 supports resolutions from VGA to WUXGA (and 1080p) and can be controlled in two ways:

1. Configuration and state pins
2. The programmable I<sup>2</sup>C serial interface (see [Table 6-1](#))

The host in a digital display system, usually a PC or consumer electronics device, contains a DVI-compatible transmitter such as the TI TFP410 that receives 24-bit pixel data along with appropriate control signals. The TFP410 encodes the signals into a high speed, low voltage, differential serial bit stream optimized for transmission over a twisted-pair cable to a display device. The display device, usually a flat-panel monitor, requires a DVI compatible receiver like the TI TFP401 to decode the serial bit stream back to the same 24-bit pixel data and control signals that originated at the host. This decoded data can then be applied directly to the flat panel drive circuitry to produce an image on the display. Because the host and display can be separated by distances up to 5 meters or more, serial transmission of the pixel data is preferred (see [Section 6.3.1](#), [Section 6.3.2](#), and [Section 6.3.3](#)).

The TFP410 integrates a high-speed digital interface, a T.M.D.S. encoder, and three differential T.M.D.S. drivers. Data is driven to the TFP410 encoder across 12 or 24 data lines, along with differential clock pair and sync signals. The flexibility of the TFP410 allows for multiple clock and data formats that enhance system performance.

The TFP410 also has enhanced PLL noise immunity, an enhancement accomplished with on-chip regulators and bypass capacitors.

The TFP410 is versatile and highly programmable to provide maximum flexibility for the user. An I<sup>2</sup>C host interface is provided to allow enhanced configurations in addition to power-on default settings programmed by pin-strapping resistors.

The TFP410 offers monitor detection through receiver detection, or hot-plug detection when I<sup>2</sup>C is enabled. The monitor detection feature allows the user enhanced flexibility when attaching to digital displays or receivers (see [Section 6.4.3](#) and the see [Section 6.6](#)).

The TFP410 has a data de-skew feature allowing the users to *de-skew* the input data with respect to the IDCK± (see [Section 6.4.2](#)).

## 6.2 Functional Block Diagram

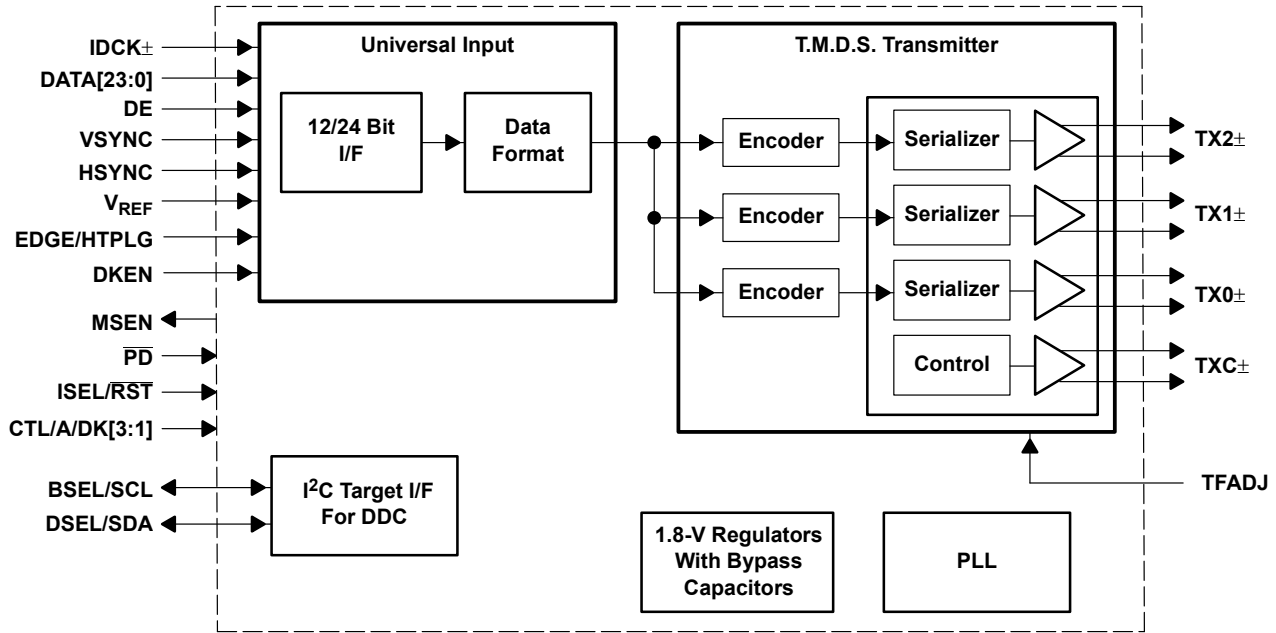

## 6.3 Feature Description

### 6.3.1 T.M.D.S. Pixel Data and Control Signal Encoding

For transition minimized differential signaling (T.M.D.S.), only one of two possible T.M.D.S. characters for a given pixel is transmitted at a given time. The transmitter keeps a running count of the number of ones and zeros previously sent and transmits the character that minimizes the number of transitions and approximates a dc balance of the transmission line. Three T.M.D.S. channels are used to transmit RGB pixel data during the active video interval (DE = High). These same three channels are also used to transmit HSYNC, VSYNC, and three control signals, CTL[3:1], during the inactive display or blanking interval (DE = Low). The following table maps the transmitted output data to the appropriate T.M.D.S. output channel in a DVI-compliant system.

INPUT PINS (VALID FOR DE = High)	T.M.D.S. OUTPUT CHANNEL	TRANSMITTED PIXEL DATA ACTIVE DISPLAY (DE = High)
DATA[23:16]	Channel 2 (TX2 ±)	Red[7:0]
DATA[15:8]	Channel 1 (TX1 ±)	Green[7:0]
DATA[7:0]	Channel 0 (TX0 ±)	Blue[7:0]
INPUT PINS (VALID FOR DE = Low)	T.M.D.S. OUTPUT CHANNEL	TRANSMITTED CONTROL DATA BLANKING INTERVAL (DE = Low)
CTL2 <sup>(1)</sup>	Channel 2 (TX2 ±)	CTL[2]
CTL1 <sup>(1)</sup>	Channel 1 (TX1 ±)	CTL[1]
HSYNC, VSYNC	Channel 0 (TX0 ±)	HSYNC, VSYNC

(1) The TFP410 encodes and transfers the CTL[2:1] inputs during the vertical blanking interval. CTL3 is reserved for HDCP and is always encoded as 0. The CTL[2:1] inputs are reserved for future use. When DE = high, CTL and SYNC pins must be held constant.

### 6.3.2 Universal Graphics Controller Interface Voltage Signal Levels

The universal graphics controller interface can operate in the following two distinct voltage modes:

- The high-swing mode where standard 3.3V CMOS signaling levels are used.
- The low-swing mode where adjustable 1.1V to 1.8V signaling levels are used.

To select the high-swing mode, the  $V_{REF}$  input pin must be tied to the 3.3V power supply.

To select the low-swing mode, the  $V_{REF}$  must be 0.55 to 0.95V.

In the low-swing mode,  $V_{REF}$  is used to set the midpoint of the adjustable signaling levels. The allowable range of values for  $V_{REF}$  is from 0.55V to 0.9V. The typical approach is to provide this from off chip by using a simple voltage-divider circuit. The minimum allowable input signal swing in the low-swing mode is  $V_{REF} \pm 0.2V$ . In low-swing mode, the  $V_{REF}$  input is common to all differential input receivers.

### 6.3.3 Universal Graphics Controller Interface Clock Inputs

The universal graphics controller interface of the TFP410 supports both fully differential and single-ended clock input modes. In the differential clock input mode, the universal graphics controller interface uses the crossover point between the IDCK+ and IDCK– signals as the timing reference for latching incoming data (DATA[23:0], DE, HSYNC, and VSYNC). Differential clock inputs provide greater common-mode noise rejection. The differential clock input mode is only available in the low-swing mode. In the single-ended clock input mode, the IDCK+ input (Pin 57) should be connected to the single-ended clock source and the IDCK– input (Pin 56) should be tied to GND.

The universal graphics controller interface of the TFP410 provides selectable 12-bit dual-edge, and 24-bit single-edge, input clocking modes. In the 12-bit dual-edge, the 12-bit data is latched on each edge of the input clock. In the 24-bit single-edge mode, the 24-bit data is latched on the rising edge of the input clock when EDGE = 1 and the falling edge of the input clock when EDGE = 0.

DKEN and DK[3:1] allow the user to compensate the skew between IDCK± and the pixel data and control signals. See [Table 6-10](#) for details.

## 6.4 Device Functional Modes

### 6.4.1 Universal Graphics Controller Interface Modes

[Table 6-1](#) is a tabular representation of the different modes for the universal graphics controller interface. The 12-bit mode is selected when BSEL=0 and the 24-bit mode when BSEL=1. The 12-bit mode uses dual-edge clocking and the 24-bit mode uses single-edge clocking. The EDGE input is used to control the latching edge in 24-bit mode, or the primary latching edge in 12-bit mode. When EDGE=1, the data input is latched on the rising edge of the input clock; and when EDGE=0, the data input is latched on the falling edge of the input clock. A fully differential input clock is available only in the low-swing mode. Single-ended clocking is not recommended in the low-swing mode as this decreases common-mode noise rejection.

Note that BSEL, DSEL, and EDGE are determined by register CTL\_1\_MODE when I<sup>2</sup>C is enabled (ISEL=1) and by input pins when I<sup>2</sup>C is disabled (ISEL=0).

**Table 6-1. Universal Graphics Controller Interface Options (Tabular Representation)**

$V_{REF}$	BSEL	EDGE	DSEL	BUS WIDTH	LATCH MODE	CLOCK EDGE	CLOCK MODE
0.55V – 0.9V	0	0	0	12-bit	Dual-edge	Falling	Differential <sup>(1) (2)</sup>
0.55V – 0.9V	0	0	1	12-bit	Dual-edge	Falling	Single-ended
0.55V – 0.9V	0	1	0	12-bit	Dual-edge	Rising	Differential <sup>(1) (2)</sup>
0.55V – 0.9V	0	1	1	12-bit	Dual-edge	Rising	Single-ended
0.55V – 0.9V	1	0	0	24-bit	Single-edge	Falling	Single-ended
0.55V – 0.9V	1	0	1	24-bit	Single-edge	Falling	Differential <sup>(1) (3)</sup>
0.55V – 0.9V	1	1	0	24-bit	Single-edge	Rising	Single-ended
0.55V – 0.9V	1	1	1	24-bit	Single-edge	Rising	Differential <sup>(1) (3)</sup>
DV <sub>DD</sub>	0	0	X	12-bit	Dual-edge	Falling	Single-ended <sup>(4)</sup>

**Table 6-1. Universal Graphics Controller Interface Options (Tabular Representation) (continued)**

V <sub>REF</sub>	BSEL	EDGE	DSEL	BUS WIDTH	LATCH MODE	CLOCK EDGE	CLOCK MODE
DV <sub>DD</sub>	0	1	X	12-bit	Dual-edge	Rising	Single-ended <sup>(4)</sup>
DV <sub>DD</sub>	1	0	X	24-bit	Single-edge	Falling	Single-ended <sup>(4)</sup>
DV <sub>DD</sub>	1	1	X	24-bit	Single-edge	Rising	Single-ended <sup>(4)</sup>

- (1) The differential clock input mode is only available in the low signal swing mode (that is, V<sub>REF</sub> ≤ 0.9V).
- (2) The TFP410 does not support a 12-bit dual-clock, single-edge input clocking mode.
- (3) The TFP410 does not support a 24-bit single-clock, dual-edge input clocking mode.
- (4) In the high-swing mode (V<sub>REF</sub> = DV<sub>DD</sub>), DSEL is a don't care; therefore, the device is always in the single-ended latch mode.

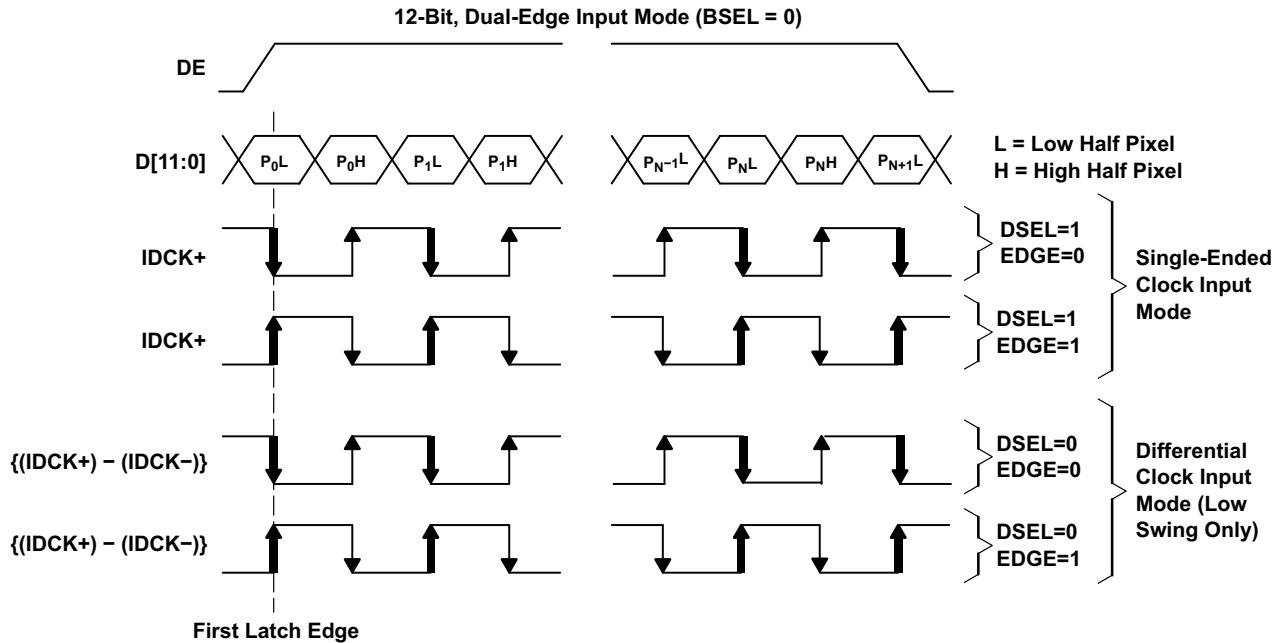

**Figure 6-1. Universal Graphics Controller Interface Options for 12-Bit Mode (Graphical Representation)**

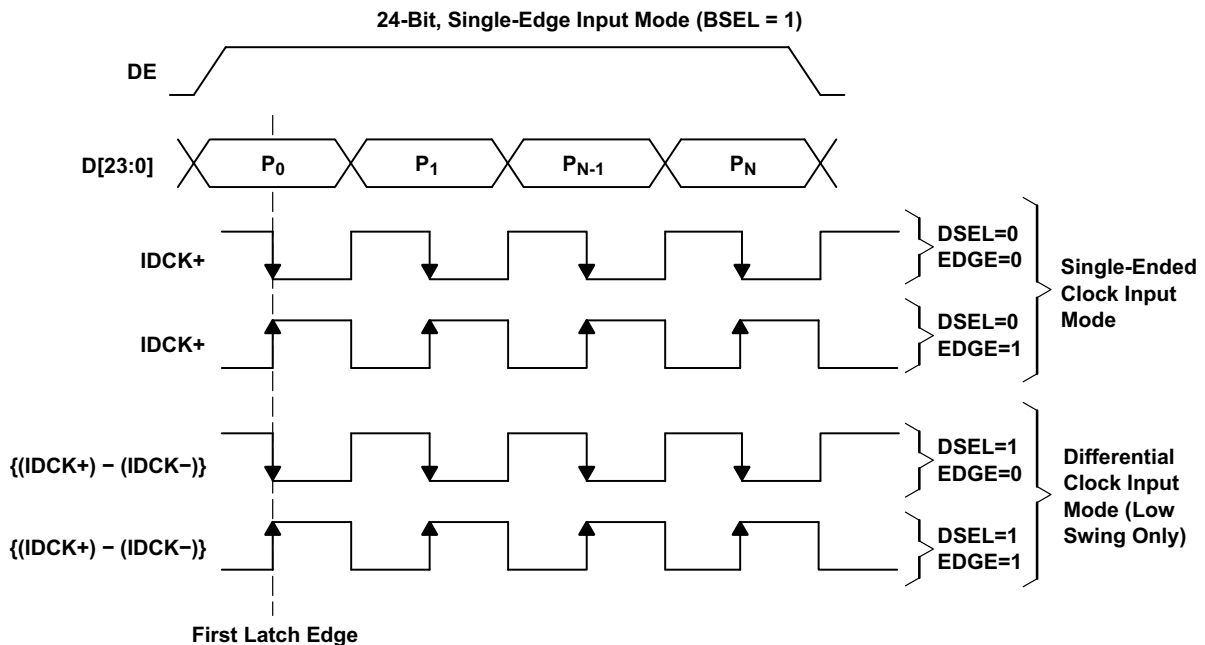

**Figure 6-2. Universal Graphics Controller Interface Options for 24-Bit Mode (Graphical Representation)**

**Table 6-2. 12-Bit Mode Data Mapping**

PIN NAME	P0		P1		P2	
	P0L	P0H	P1L	P1H	P2L	P2H
	LOW	HIGH	LOW	HIGH	LOW	HIGH
D11	G0[3]	R0[7]	G1[3]	R1[7]	G2[3]	R2[7]
D10	G0[2]	R0[6]	G1[2]	R1[6]	G2[2]	R2[6]
D9	G0[1]	R0[5]	G1[1]	R1[5]	G2[1]	R2[5]
D8	G0[0]	R0[4]	G1[0]	R1[4]	G2[0]	R2[4]
D7	B0[7]	R0[3]	B1[7]	R1[3]	B2[7]	R2[3]
D6	B0[6]	R0[2]	B1[6]	R1[2]	B2[6]	R2[2]
D5	B0[5]	R0[1]	B1[5]	R1[1]	B2[5]	R2[1]
D4	B0[4]	R0[0]	B1[4]	R1[0]	B2[4]	R2[0]
D3	B0[3]	G0[7]	B1[3]	G1[7]	B2[3]	G2[7]
D2	B0[2]	G0[6]	B1[2]	G1[6]	B2[2]	G2[6]
D1	B0[1]	G0[5]	B1[1]	G1[5]	B2[1]	G2[5]
D0	B0[0]	G0[4]	B1[0]	G1[4]	B2[0]	G2[4]

**Table 6-3. 24-Bit Mode Data Mapping**

PIN NAME	P0	P1	P2	PIN NAME	P0	P1	P2
D23	R0[7]	R1[7]	R2[7]	D11	G0[3]	G1[3]	G2[3]
D22	R0[6]	R1[6]	R2[6]	D10	G0[2]	G1[2]	G2[2]
D21	R0[5]	R1[5]	R2[5]	D9	G0[1]	G1[1]	G2[1]
D20	R0[4]	R1[4]	R2[4]	D8	G0[0]	G1[0]	G2[0]
D19	R0[3]	R1[3]	R2[3]	D7	B0[7]	B1[7]	B2[7]
D18	R0[2]	R1[2]	R2[2]	D6	B0[6]	B1[6]	B2[6]
D17	R0[1]	R1[1]	R2[1]	D5	B0[5]	B1[5]	B2[5]
D16	R0[0]	R1[0]	R2[0]	D4	B0[4]	B1[4]	B2[4]
D15	G0[7]	G1[7]	G2[7]	D3	B0[3]	B1[3]	B2[3]
D14	G0[6]	G1[6]	G2[6]	D2	B0[2]	B1[2]	B2[2]
D13	G0[5]	G1[5]	G2[5]	D1	B0[1]	B1[1]	B2[1]
D12	G0[4]	G1[4]	G2[4]	D0	B0[0]	B1[0]	B2[0]

### 6.4.2 Data De-skew Feature

The de-skew feature allows adjustment of the input setup/hold time. Specifically, the input data DATA[23:0] can be latched slightly before or after the latching edge of the clock IDCK± depending on the amount of de-skew desired. When de-skew enable (DKEN) is enabled, the amount of de-skew is programmable by setting the three bits DK[3:1]. When disabled, a default de-skew setting is used. To allow maximum flexibility and ease of use, DKEN and DK[3:1] are accessed directly through configuration pins when I<sup>2</sup>C is disabled, or through registers of the same name when I<sup>2</sup>C is enabled. When using I<sup>2</sup>C mode, the DKEN pin should be tied to ground to avoid a floating input.

The input setup/hold time can be varied with respect to the input clock by an amount  $t_{(CD)}$  given by the formula in Equation 1.

$$t_{(CD)} = (DK[3:1] - 4) \times t_{(STEP)} \quad (1)$$

where

- $t_{(STEP)}$  is the adjustment increment amount
- $DK[3:1]$  is a number from 0 to 7 represented as a 3-bit binary number
- $t_{(CD)}$  is the cumulative de-skew amount

$(DK[3:1]-4)$  is simply a multiplier in the range  $\{-4,-3,-2,-1, 0, 1, 2, 3\}$  for  $t_{(STEP)}$ . Therefore, data can be latched in increments from 4 times the value of  $t_{(STEP)}$  before the latching edge of the clock to 3 times the value of  $t_{(STEP)}$  after the latching edge. Note that the input clock is not changed, only the time when data is latched with respect to the clock.

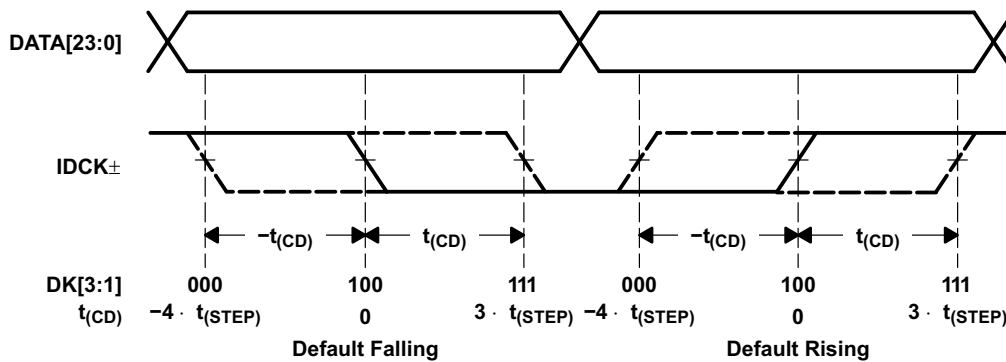

Figure 6-3. A Graphical Representation of the De-Skew Function

### 6.4.3 Hot Plug/Unplug (Auto Connect/Disconnect Detection)

TFP410 supports hot plug/unplug (auto connect/disconnect detection) for the DVI link. The receiver sense input (RSEN) bit indicates if a DVI receiver is connected to TXC+ and TXC-. The HTPLG bit reflects the current state of the HTPLG pin connected to the monitor via the DVI connector. When I<sup>2</sup>C is disabled (ISEL=0), the RSEN value is available on the MSEN pin. When I<sup>2</sup>C is enabled, the connection status of the DVI link and HTPLG sense pins are provided by the CTL\_2\_MODE register. The MSEL bits of the CTL\_2\_MODE register can be used to program the MSEN to output the HTPLG value, the RSEN value, an interrupt, or be disabled.

The source of the interrupt event is selected by TSEL in the CTL\_2\_MODE register. An interrupt is generated by a change in status of the selected signal. The interrupt status is indicated in the MDI bit of CTL\_2\_MODE and can be output via the MSEN pin. The interrupt continues to be asserted until a 1 is written to the MDI bit, resetting the bit back to 0. Writing 0 to the MDI bit has no effect.

### 6.4.4 Device Configuration and I<sup>2</sup>C RESET Description

The TFP410 device configuration can be programmed by several different methods to allow maximum flexibility for the user's application. Device configuration is controlled depending on the state of the ISEL/  $\overline{RST}$  pin, configuration pins (BSEL, DSEL, EDGE,  $V_{REF}$ ) and state pins ( $\overline{PD}$ , DKEN). I<sup>2</sup>C bus select and I<sup>2</sup>C RESET (active low) are shared functions on the ISEL/  $\overline{RST}$  pin, which operates asynchronously.

Holding ISEL/  $\overline{RST}$  low causes the device configuration to be set by the configuration pins (BSEL, DSEL, EDGE, and  $V_{REF}$ ) and state pins ( $\overline{PD}$ , DKEN). The I<sup>2</sup>C bus is disabled.

Holding ISEL/  $\overline{RST}$  high causes the chip configuration to be set based on the configuration bits (BSEL, DSEL, EDGE) and state bits ( $\overline{PD}$ , DKEN) in the I<sup>2</sup>C registers. The I<sup>2</sup>C bus is enabled.

Momentarily bringing ISEL/  $\overline{\text{RST}}$  low and then back high while the device is operating in normal or power-down mode will RESET the I<sup>2</sup>C registers to their default values. The device configuration will be changed to the default power-up state with I<sup>2</sup>C enabled. After power up, the device must be reset. It is suggested that this pin be tied to the system reset signal, which is low during power up and is then asserted high after all the power supplies are fully functional.

#### 6.4.5 DE Generator

The TFP410 contains a DE generator that can be used to generate an internal DE signal when the original data source does not provide one. There are several I<sup>2</sup>C programmable values that control the DE generator (see [Figure 6-4](#)). DE\_GEN in the DE\_CTL register enables this function. When enabled, the DE pin is ignored.

DE\_TOP and DE\_LIN are line counts used to control the number of lines after VSYNC goes active that DE is enabled, and the total number of lines that DE remains active, respectively. The polarity of VSYNC must be set by VS\_POL in the DE\_CTL register.

DE\_DLY and DE\_CNT are pixel counts used to control the number of pixels after HSYNC goes active that DE is enabled, and the total number of pixels that DE remains active, respectively. The polarity of HSYNC must be set by HS\_POL in the DE\_CTL register.

The TFP410 also counts the total number of HSYNC pulses between VSYNC pulses, and the total number of pixels between HSYNC pulses. These values, the total vertical and horizontal resolutions, are available in V\_RES and H\_RES, respectively. These values are available at all times, whether or not the DE generator is enabled.

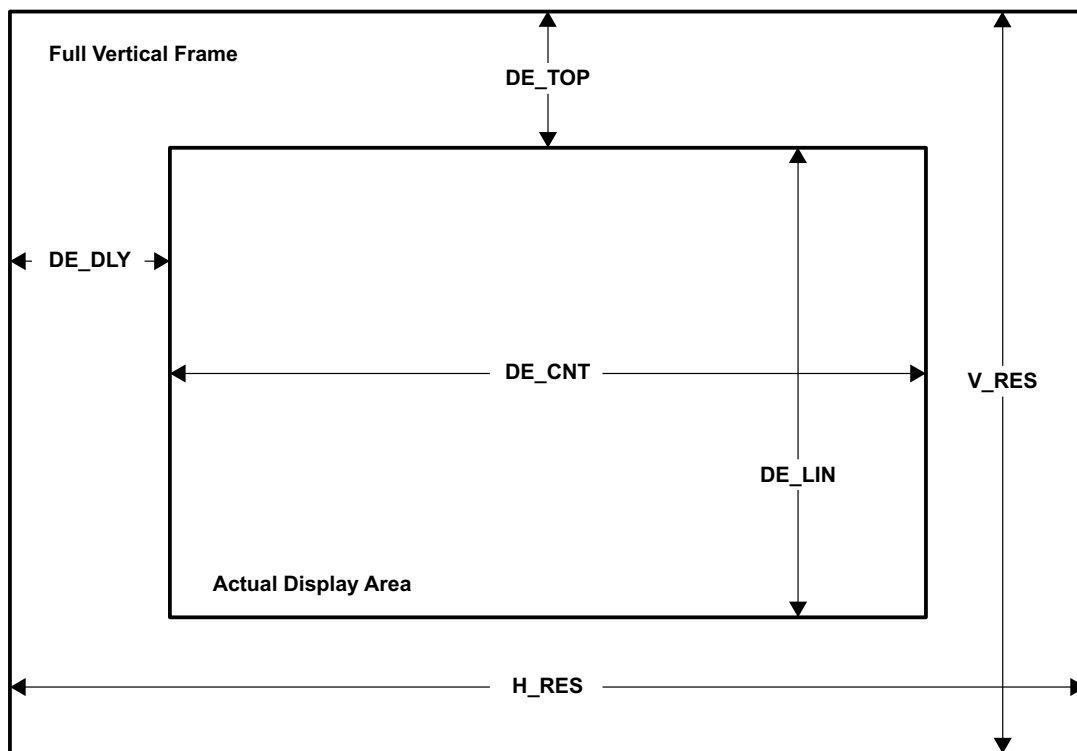
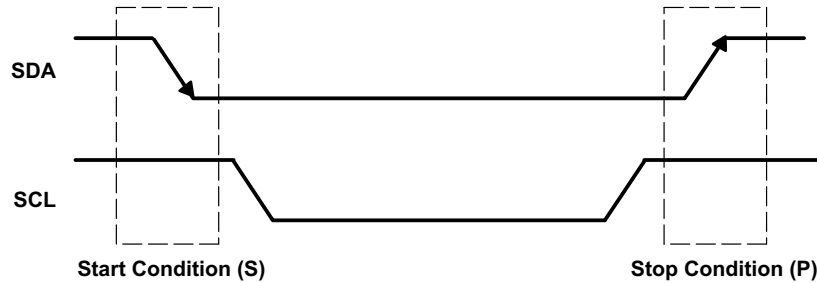

Figure 6-4. DE Generator Register Functions

## 6.5 Programming

### 6.5.1 I<sup>2</sup>C Interface

The I<sup>2</sup>C interface is used to access the internal TFP410 registers. This two-pin interface consists of the SCL clock line and the SDA serial data line. The basic I<sup>2</sup>C access cycles are shown in [Figure 6-5](#) and [Figure 6-6](#).



**Figure 6-5. I<sup>2</sup>C Start and Stop Conditions**

The basic access write cycle consists of the following:

1. A start condition
2. A target address cycle
3. A sub-address cycle
4. Any number of data cycles
5. A stop condition

The basic access read cycle consists of the following:

1. A start condition
2. A target write address cycle
3. A sub-address cycle
4. A restart condition
5. A target read address cycle
6. Any number of data cycles
7. A stop condition

The start and stop conditions are shown in [Figure 6-5](#). The high to low transition of SDA while SCL is high defines the start condition. The low to high transition of SDA while SCL is high defines the stop condition. Each cycle, data or address, consists of 8 bits of serial data followed by one acknowledge bit generated by the receiving device. Thus, each data/address cycle contains 9 bits as shown in [Figure 6-6](#).

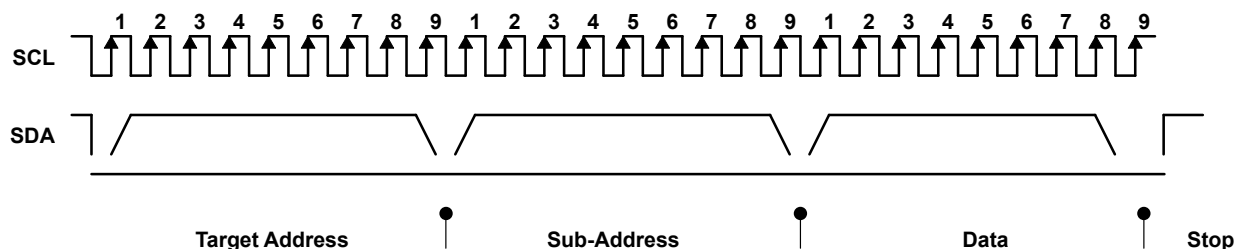

**Figure 6-6. I<sup>2</sup>C Access Cycles**

Following a start condition, each I<sup>2</sup>C device decodes the target address. The TFP410 responds with an acknowledge by pulling the SDA line low during the ninth clock cycle if it decodes the address as its address. During subsequent sub-address and data cycles, the TFP410 responds with acknowledge as shown in [Figure 6-7](#). The sub-address is auto-incremented after each data cycle.

The transmitting device must not drive the SDA signal during the acknowledge cycle so that the receiving device may drive the SDA signal low. The controller indicates a not acknowledge condition ( $\bar{A}$ ) by keeping the SDA

signal high just before it asserts the stop condition (P). This sequence terminates a read cycle as shown in Figure 6-8.

The target address consists of 7 bits of address along with 1 bit of read/write information (read = 1, write = 0) as shown below in Figure 6-6 and Figure 6-7. For the TFP410, the selectable target addresses (including the R/W bit) using A[3:1] are 0x70, 0x72, 0x74, 0x76, 0x78, 0x7A, 0x7C, and 0x7E for write cycles and 0x71, 0x73, 0x75, 0x77, 0x79, 0x7B, 0x7D, and 0x7F for read cycles.



Where:

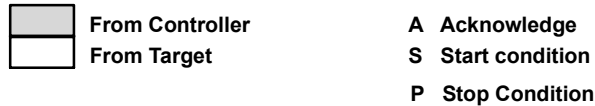
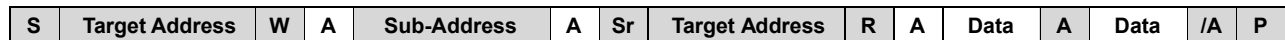

Figure 6-7. I<sup>2</sup>C Write Cycle



Where:

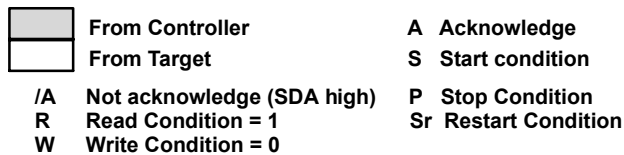

Figure 6-8. I<sup>2</sup>C Read Cycle

## 6.6 Register Maps

The TFP410 is a standard I<sup>2</sup>C target device. All the registers can be written and read through the I<sup>2</sup>C interface (unless otherwise specified). The TFP410 target machine supports only byte read and write cycles. Page mode is not supported. The 8-bit binary address of the I<sup>2</sup>C machine is 0111 A3A2A1X, where A[3:1] are pin programmable or set to 000 by default. The I<sup>2</sup>C base address of the TFP410 is dependent on A[3:1] (pins 6, 7 and 8 respectively) as shown below.

A[3:1]	WRITE ADDRESS (Hex)	READ ADDRESS (Hex)
000	70	71
001	72	73
010	74	75
011	76	77
100	78	79
101	7A	7B
110	7C	7D
111	7E	7F

REGISTER	RW	SUB-ADDRESS	BIT7	BIT6	BIT5	BIT4	BIT3	BIT2	BIT1	BIT0
VEN_ID	R	00	VEN_ID[7:0]							
	R	01	VEN_ID[15:8]							
DEV_ID	R	02	DEV_ID[7:0]							
	R	03	DEV_ID[15:8]							
REV_ID	R	04	REV_ID[7:0]							
RESERVED	R	05-07	Reserved							

REGISTER	RW	SUB-ADDRESS	BIT7	BIT6	BIT5	BIT4	BIT3	BIT2	BIT1	BIT0
CTL_1_MODE	RW	08	RSVD	TDIS	VEN	HEN	DSEL	BSEL	EDGE	PD
CTL_2_MODE	RW	09	VLOW	MSEL			TSEL	RSEN	HTPLG	MDI
CTL_3_MODE	RW	0A	DK			DKEN	CTL			RSVD
CFG	R	0B	CFG							
RESERVED	RW	0C-31	Reserved							
DE_DLY	RW	32	DE_DLY[7:0]							
DE_CTL	RW	33	RSVD	DE_GEN	VS_POL	HS_POL	RSVD			DE_DLY[8]
DE_TOP	RW	34	RSVD	DE_DLY[6:0]						
RESERVED	RW	35	Reserved							
DE_CNT	RW	36	DE_CNT[7:0]							
	RW	37	Reserved				DE_CNT[10:8]			
DE_LIN	RW	38	DE_LIN[7:0]							
	RW	39	Reserved				DE_LIN[10:8]			
H_RES	R	3A	H_RES[7:0]							
	R	3B	Reserved				H_RES[10:8]			
V_RES	R	3C	V_RES[7:0]							
	R	3D	Reserved				V_RES[10:8]			
RESERVED	R	3E-FF								

### 6.6.1 VEN\_ID Register (Sub-Address = 01-00 ) [reset = 0x014C]

**Figure 6-9. VEN\_ID Register**

15	14	13	12	11	10	9	8	7	6	5	4	3	2	1	0
VEN_ID[15:8]								VEN_ID[7:0]							

**Table 6-4. VEN\_ID Field Descriptions**

Bit	Field	Type	Description
15:8	VEN_ID	R	These read-only registers contain the 16-bit Texas Instruments vendor ID. VEN_ID is hardwired to 0x014C.
7:0	VEN_ID	R	

### 6.6.2 DEV\_ID Register (Sub-Address = 03-02) [reset = 0x0410]

**Figure 6-10. DEV\_ID Register**

15	14	13	12	11	10	9	8	7	6	5	4	3	2	1	0
DEV_ID[15:8]								DEV_ID[7:0]							

**Table 6-5. DEV\_ID Register Field Descriptions**

Bit	Field	Type	Description
15:8	DEV_ID	R	These read-only registers contain the 16-bit device ID for the TFP410. DEV_ID is hardwired to 0x0410.
7:0	DEV_ID	R	

### 6.6.3 REV\_ID Register (Sub-Address = 04) [reset = 0x00]

Figure 6-11. REV\_ID Register

7	6	5	4	3	2	1	0
REV_ID[7:0]							

Table 6-6. REV\_ID Register Field Descriptions

Bit	Field	Type	Description
7:0	REV_ID	R	This read-only register contains the revision ID.

### 6.6.4 Reserved Register (Sub-Address = 07–05) [reset = 0x641400]

Figure 6-12. Reserved

15	14	13	12	11	10	9	8	7	6	5	4	3	2	1	0
RESERVED[15:8]								RESERVED[7:0]							

Table 6-7. Reserved Field Descriptions

Bit	Field	Type	Description
15:8	RESERVED	Read Only	—
7:0	RESERVED	Read Only	—

### 6.6.5 CTL\_1\_MODE (Sub-Address = 08) [reset = 0xBE]

Figure 6-13. CTL\_1\_MODE Register

7	6	5	4	3	2	1	0
RSVD	TDIS	VEN	HEN	DSEL	BSEL	EDGE	PD

Table 6-8. CTL\_1\_MODE Field Descriptions

Bit	Field	Type	Description
7	RSVD	R/W	Reserved
6	TDIS	R/W	This read/write register contains the T.M.D.S. disable mode 0: T.M.D.S. circuitry enable state is determined by PD. 1: T.M.D.S. circuitry is disabled.
5	VEN	R/W	This read/write register contains the vertical sync enable mode. 0: VSYNC input is transmitted as a fixed low 1: VSYNC input is transmitted in its original state
4	HEN	R/W	This read/write register contains the horizontal sync enable mode. 0: HSYNC input is transmitted as a fixed low 1: HSYNC input is transmitted in its original state
3	DSEL	R/W	This read/write register is used in combination with BSEL and VREF to select the single-ended or differential input clock mode. In the high-swing mode, DSEL is a don't care because IDCK is always single-ended.
2	BSEL	R/W	This read/write register contains the input bus select mode. 0: 12-bit operation with dual-edge clock 1: 24-bit operation with single-edge clock
1	EDGE	R/W	This read/write register contains the edge select mode. 0: Input data latches to the falling edge of IDCK+ 1: Input data latches to the rising edge of IDCK+
0	PD	R/W	This read/write register contains the power-down mode. 0: Power down (default after RESET) 1: Normal operation

### 6.6.6 CTL\_2\_MODE Register (Sub-Address = 09) [reset = 0x00]

**Figure 6-14. CTL\_2\_MODE Register**

7	6	5	4	3	2	1	0
VLOW	MSEL[3:1]			TSEL	RSEN	HTPLG	MDI

**Table 6-9. CTL\_2\_MODE Field Descriptions**

Bit	Field	Type	Description
7	VLOW	R/W	This read only register indicates the VREF input level. 0: This bit is a logic level (0) if the VREF analog input selects high-swing inputs 1: This bit is a logic level (1) if the VREF analog input selects low-swing inputs
6:4	MSEL[3:1]	R/W	This read/write register contains the source select of the monitor sense output pin. 000: Disabled. MSEN output high 001: Outputs the MDI bit (interrupt) 010: Outputs the RSEN bit (receiver detect) 011: Outputs the HTPLG bit (hot plug detect)
3	TSEL	R/W	This read/write register contains the interrupt generation source select. 0: Interrupt bit (MDI) is generated by monitoring RSEN 1: Interrupt bit (MDI) is generated by monitoring HTPLG
2	RSEN	R/W	This read only register contains the receiver sense input logic state, which is valid only for dc-coupled systems. 0: A powered-on receiver is not detected 1: A powered-on receiver is detected (that is, connected to the DVI transmitter outputs)
1	HTPLG	R/W	This read only register contains the hot plug detection input logic state. 0: Logic level detected on the EDGE/HTPLG pin (pin 9) 1: High level detected on the EDGE/HTPLG pin (pin 9)
0	MDI	R/W	This read/write register contains the monitor detect interrupt mode. 0: Detected logic level change in detection signal (to clear, write one to this bit) 1: Logic level remains the same

### 6.6.7 CTL\_3\_MODE Register (Sub-Address = 0A) [reset = 0x80]

**Figure 6-15. CTL\_3\_MODE Register**

7	6	5	4	3	2	1	0
DK[3:1]			DKEN	RSVD	CTL[2:1]		RSVD

**Table 6-10. CTL\_3\_MODE Register Field Descriptions**

Bit	Field	Type	Description
7:5	DK[3:1]	RW	This read/write register contains the de-skew setting, each increment adjusts the skew by t(STEP). 000: Step 1 (minimum setup/maximum hold) 001: Step 2 010: Step 3 011: Step 4 100: Step 5 (default) 101: Step 6 110: Step 7 111: Step 8 (maximum setup/minimum hold)
4	DKEN	RW	This read/write register controls the data de-skew enable. 0: Data de-skew is disabled, the values in DK[3:1] are not used 1: Data de-skew is enabled, the de-skew setting is controlled through DK[3:1]
3	RSVD	RW	—
2:1	CTL[2:1]	RW	This read/write register contains the values of the two CTL[2:1] bits that are output on the DVI port during the blanking interval.
0	RSVD	RW	—

### 6.6.8 CFG Register (Sub-Address = 0B)

Figure 6-16. CFG Register

7	6	5	4	3	2	1	0
CFG[7:0]							

Table 6-11. CFG Register Field Descriptions

Bit	Field	Type	Description
7:0 (D[23:16])	CFG	Read Only	This read-only register contains the state of the inputs D[23:16]. These pins can be used to provide the user with selectable configuration data through the I <sup>2</sup> C bus.

### 6.6.9 RESERVED Register (Sub-Address = 0E–0C) [reset = 0x97D0A9]

Figure 6-17. RESERVED Register

7	6	5	4	3	2	1	0
RESERVED							

Table 6-12. RESERVED Register Field Descriptions

Bit	Field	Type	Description
7:0	RESERVED	R/W	—

### 6.6.10 DE\_DLY Register (Sub-Address = 32) [reset = 0x00]

Figure 6-18. DE\_DLY Register

7	6	5	4	3	2	1	0
DE_DLY[7:0]							

Table 6-13. DE\_DLY Field Descriptions

Bit	Field	Type	Description
7:0	DE_DLY	R/W	This read/write register defines the number of pixels after HSYNC goes active that DE is generated, when the DE generator is enabled. The value must be less than or equal to (2047 - DE_CNT)

### 6.6.11 DE\_CTL Register (Sub-Address = 33) [reset = 0x00]

Figure 6-19. DE\_CTL Register

7	6	5	4	3	2	1	0
Reserved	DE_GEN	VS_POL	HS_POL	Reserved			DE_DLY[8]

Table 6-14. DE\_CTL Register Field Descriptions

Bit	Field	Type	Description
7	Reserved	R/W	—
6	DE_GEN	R/W	This read/write register enables the internal DE generator. 0: DE generator is disabled. Signal required on DE pin 1: DE generator is enabled. DE pin is ignored.
5	VS_POL	R/W	This read/write register sets the VSYNC polarity. 0: VSYNC is considered active low. 1: VSYNC is considered active high. Line counts are reset on the VSYNC active edge.
4	HS_POL	R/W	This read/write register sets the HSYNC polarity. 0: HSYNC is considered active low. 1: HSYNC is considered active high. Pixel counts are reset on the HSYNC active edge.
1:3	Reserved	R/W	—
0	DE_DLY[8]	R/W	This read/write register contains the top bit of DE_DLY.

### 6.6.12 DE\_TOP Register (Sub-Address = 34) [reset = 0x00]

**Figure 6-20. DE\_TOP Register**

7	6	5	4	3	2	1	0
DE_TOP[7:0]							

**Table 6-15. DE\_TOP Register Field Descriptions**

Bit	Field	Type	Description
7:0	DE_TOP	R/W	This read/write register defines the number of pixels after VSYNC goes active that DE is generated, when the DE generator is enabled.

### 6.6.13 DE\_CNT Register (Sub-Address = 37–36) [reset = 0x0000]

**Figure 6-21. DE\_CNT Register**

7	6	5	4	3	2	1	0
DE_CNT[7:0]							
Reserved				DE_CNT[10:8]			

**Table 6-16. DE\_CNT Register Field Descriptions**

Bit	Field	Type	Description
10:8	DE_CNT	R/W	These read/write registers define the width of the active display, in pixels, when the DE generator is enabled. The value must be less than or equal to (2047 - DE_DLY).
7:0	DE_CNT	R/W	

### 6.6.14 DE\_LIN Register (Sub-Address = 39–38) [reset = 0x0000]

**Figure 6-22. DE\_LIN Register**

7	6	5	4	3	2	1	0
DE_LIN[7:0]							
Reserved				DE_LIN[10:8]			

**Table 6-17. DE\_LIN Register Field Descriptions**

Bit	Field	Type	Description
10:8	DE_LIN	R/W	These read/write registers define the height of the active display, in lines, when the DE generator is enabled.
7:0	DE_LIN	R/W	

### 6.6.15 H\_RES Register (Sub-Address = 3B–3A)

**Figure 6-23. H\_RES Register**

7	6	5	4	3	2	1	0
H_RES[7:0]							
Reserved				H_RES[10:8]			

**Table 6-18. H\_RES Register Field Descriptions**

Bit	Field	Type	Description
10:8	H_RES	Read Only	These read-only registers return the number of pixels between consecutive HSYNC pulses.
7:0	H_RES	Read Only	

### 6.6.16 V\_RES Register (Sub-Address = 3D–3C)

**Figure 6-24. V\_RES Register**

7	6	5	4	3	2	1	0
V_RES[7:0]							
Reserved					V_RES[10:8]		

**Table 6-19. V\_RES Register Field Descriptions**

Bit	Field	Type	Description
10:8	V_RES	Read Only	These read-only registers return the number of lines between consecutive VSYNC pulses.
7:0	V_RES	Read Only	

## 7 Application and Implementation

### Note

Information in the following applications sections is not part of the TI component specification, and TI does not warrant its accuracy or completeness. TI's customers are responsible for determining suitability of components for their purposes, as well as validating and testing their design implementation to confirm system functionality.

### 7.1 Application Information

The TFP410 is a DVI-compliant digital transmitter that is used in digital host monitor systems to T.M.D.S. encode and serialize RGB pixel data streams. TFP410 supports resolutions from VGA to WUXGA (and 1080p). The host in a digital display system, usually a PC or consumer electronics device, contains a DVI-compatible transmitter such as the TI TFP410 that receives 24-bit pixel data along with appropriate control signals. The TFP410 encodes the signals into a high speed, low voltage, differential serial bit stream optimized for transmission over a twisted-pair cable to a display device such as the TFP401.

### 7.2 Typical Application

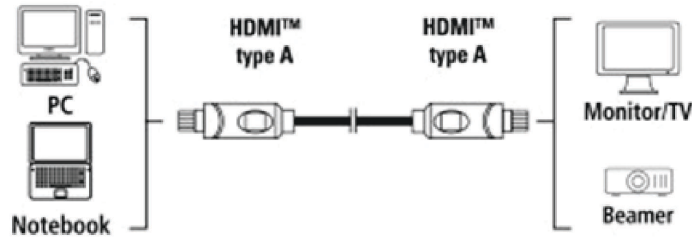

**Figure 7-1. Typical Application for the TFP410 Device**

#### 7.2.1 Design Requirements

PARAMETER	VALUE
Power supply	3.3V dc at 1 A
Input clock	Single-ended
Input clock frequency range	25MHz — 165MHz
Output format	24 bits/pixel
Input clock latching	Rising edge
I <sup>2</sup> C EEPROM support	No
De-skew	No

**TFP410**

SLDS145D – OCTOBER 2001 – REVISED FEBRUARY 2024

**7.2.2 Detailed Design Procedure**

**7.2.2.1 Data and Control Signals**

The trace length of data and control signals out of the receiver should be kept as close to equal as possible. Trace separation should be approximately 5 times the height. As a general rule, traces also should be less than 2.8" if possible (longer traces can be acceptable).

$$\text{Delay} = 85 \times \text{SQRT} \times \text{er} \tag{2}$$

where

- er = 4.35; relative permativity of 50% resin FR-4 at 1 GHz
- Delay = 177 ps/in

$$\text{Length of rising edge} = \text{Tr(ps)} / \text{Delay}; \text{Tr} = 3 \text{ ns} \tag{3}$$

where

- = 3000 ps / 177 ps per inch
- = 16.9 inches

$$\text{Length of rising edge} / 6 = \text{Max length of trace for lumped circuit.} \tag{4}$$

$$16.9 / 6 = 2.8 \text{ inches} \tag{5}$$

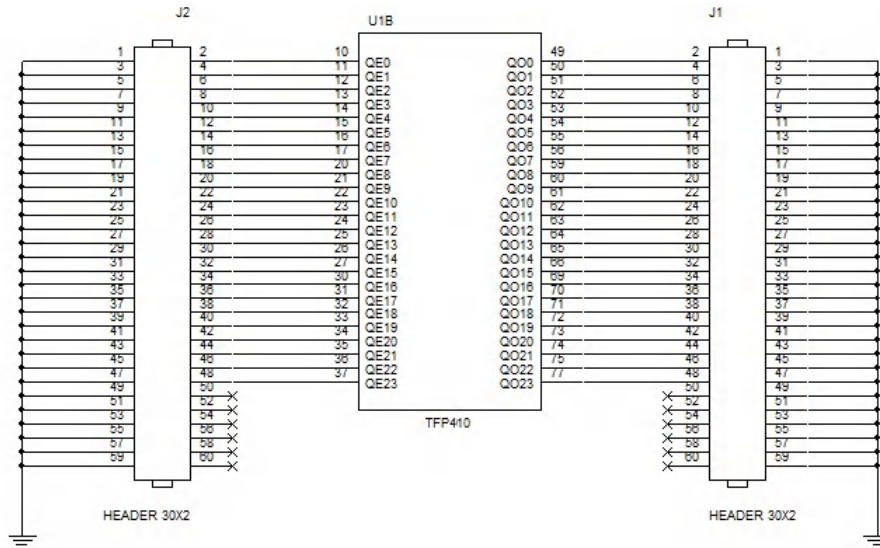

**Figure 7-2. Data Signals**

**7.2.2.2 Configuration Options**

The TFP410 can be configured in several modes depending on the required input format, for example 1 byte/clock, 2 bytes/clock, falling/rising clock edge.

Refer to [Table 6-1](#) for more information about configuration options.

### 7.2.2.3 Power Supplies Decoupling

Digital, analog, and PLL supplies must be decoupled from each other to avoid electrical noise on the PLL and the core.

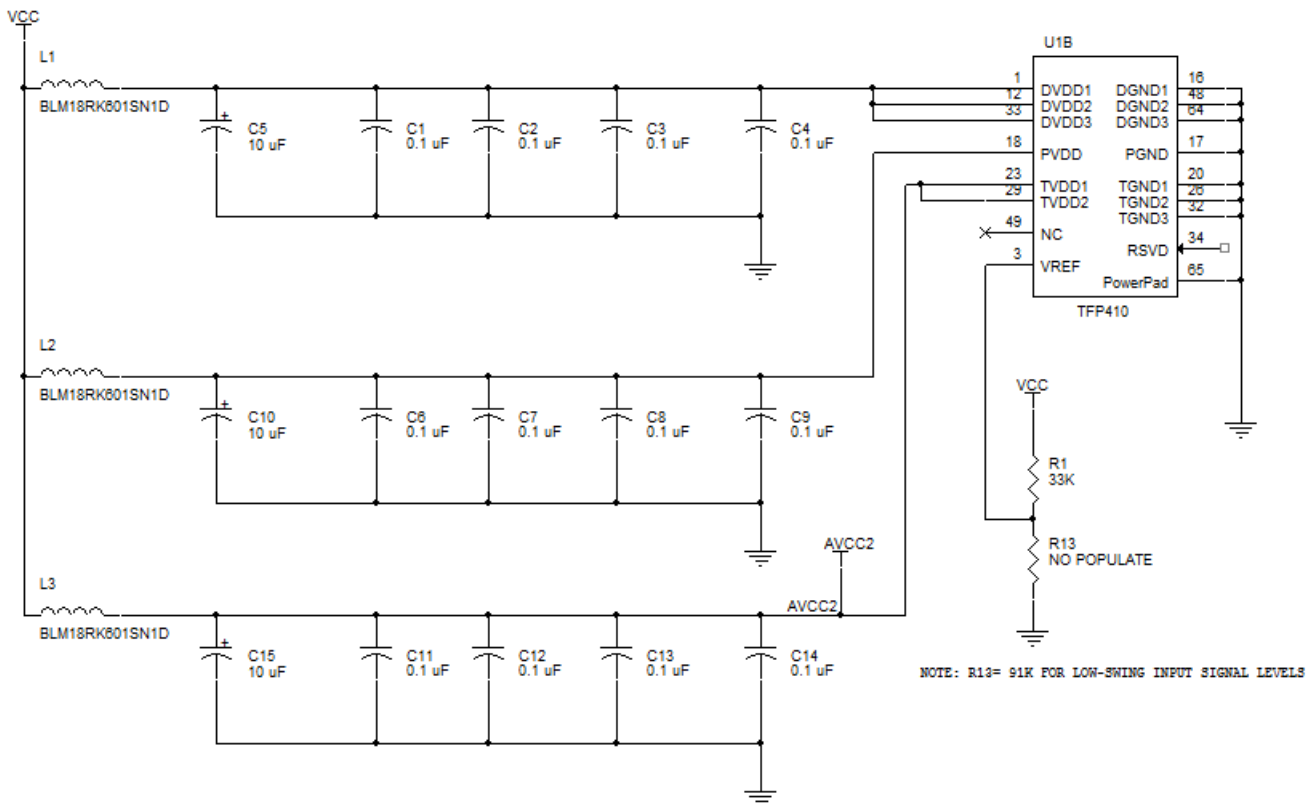

Figure 7-3. Power Decoupling

### 7.2.3 Application Curves

Sometimes the Panel does not support the same format as the GPU (graphics processor unit). In these cases the user must decide how to connect the unused bits.

Figure 7-4 and Figure 7-5 show the mismatches between the 18-bit GPU and a 24-bit LCD where “x” and “y” represent the 2 LSB of the Panel.

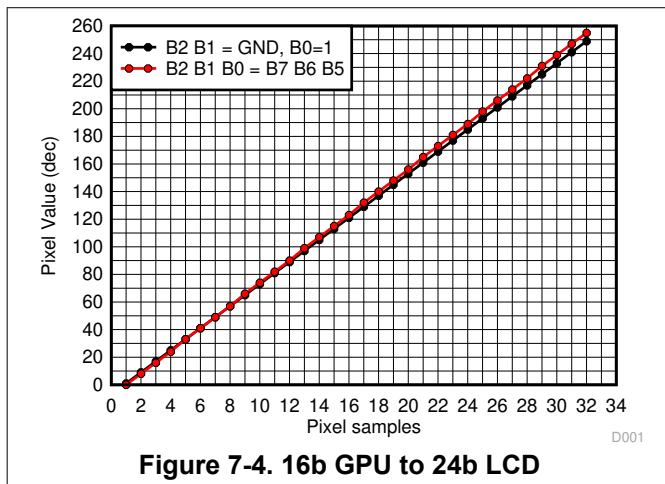

Figure 7-4. 16b GPU to 24b LCD

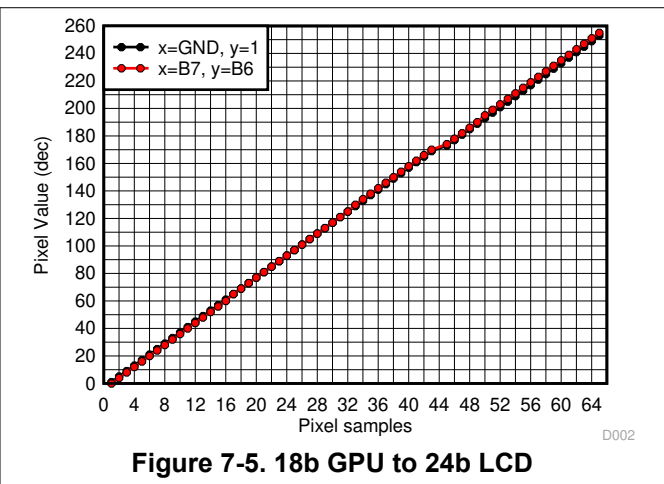

Figure 7-5. 18b GPU to 24b LCD

## 7.3 Power Supply Recommendations

Use solid ground planes. Tie ground planes together with as many vias as is practical. This will provide a desirable return path for current. Each supply should be on separate split power planes, where each power plane should be as large an area as possible. Connect PanelBus receiver power and ground pins and all bypass caps to appropriate power or ground plane with via. Vias should be as fat and short as practical, the goal is to minimize the inductance.

### 7.3.1 DVDD

Place one 0.01 $\mu$ F capacitor as close as possible between each DVDD device pins and ground. A 22 $\mu$ F tantalum capacitor should be placed between the supply and 0.01 $\mu$ F capacitors. A ferrite bead should be used between the source and the 22 $\mu$ F capacitor.

### 7.3.2 TVDD

Place one 0.01 $\mu$ F capacitor as close as possible between each TVDD device pins and ground. A 22 $\mu$ F tantalum capacitor should be placed between the supply and 0.01 $\mu$ F capacitors. A ferrite bead should be used between the source and the 22 $\mu$ F capacitor.

### 7.3.3 PVDD

Place three 0.01 $\mu$ F capacitors in parallel as close as possible between the PVDD device pin and ground. A 22 $\mu$ F tantalum capacitor should be placed between the supply and 0.01 $\mu$ F capacitors. A ferrite bead should be used between the source and the 22 $\mu$ F capacitor.

## 7.4 Layout

### 7.4.1 Layout Guidelines

#### 7.4.1.1 Layer Stack

The pinout of Texas Instruments' High Speed Interface (HSI) devices features differential signal pairs and the remaining signals comprise the supply rails, VCC and ground, and lower-speed signals, such as control pins. As an example, consider a device X which is a repeater/re-driver, so both inputs and outputs are high-speed differential signals. These guidelines can be applied to other high-speed devices such as drivers, receivers, multiplexers, and so on.

A minimum of four layers is required to accomplish a low-EMI PCB design. Layer stacking should be in the following order (top-to-bottom): high-speed differential signal layer, ground plane, power plane and control signal layer.

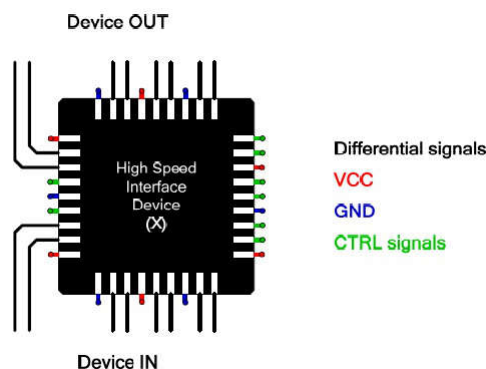

**Figure 7-6. PCB Stack Up**

### 7.4.1.2 Routing High-Speed Differential Signal Traces (*RxC-*, *RxC+*, *Rx0-*, *Rx0+*, *Rx1-*, *Rx1+*, *Rx2-*, *Rx2+*)

Trace impedance should be controlled for optimal performance. Each differential pair should be equal in length and symmetrical and should have equal impedance to ground with a trace separation of 2 times to 4 times the height. A differential trace separation of 4 times the height yields about 6% cross-talk (6% effect on impedance).

We recommend that differential trace routing should be side-by-side, though it is not important that the differential traces be tightly coupled together, because tight coupling is not achievable on PCB traces. Typical ratios on PCBs are only 20% to 50%; 99.9% is the value of a well balanced twisted pair cable. Each differential trace should be as short as possible (< 2 inches is preferable) with no 90° angles. These high-speed transmission traces should be on layer 1, which is the top layer.

*RxC-*, *RxC+*, *Rx0-*, *Rx0+*, *Rx1-*, *Rx1+*, *Rx2-*, *Rx2+* signals all route directly from the DVI connector pins to the device, no external components are needed.

#### 7.4.1.3 DVI Connector

Clear-out holes for connector pins should leave space between pins to allow continuous ground through the pin field. Allow enough spacing in ground plane around signal pins vias however, keep enough copper between vias to allow for ground current to flow between the vias. Avoid creating a large ground plane slot around the entire connector, because minimizing the via capacitance is the goal.

#### 7.4.2 Layout Example

DVI connector trace matching is shown in [Figure 7-7](#).

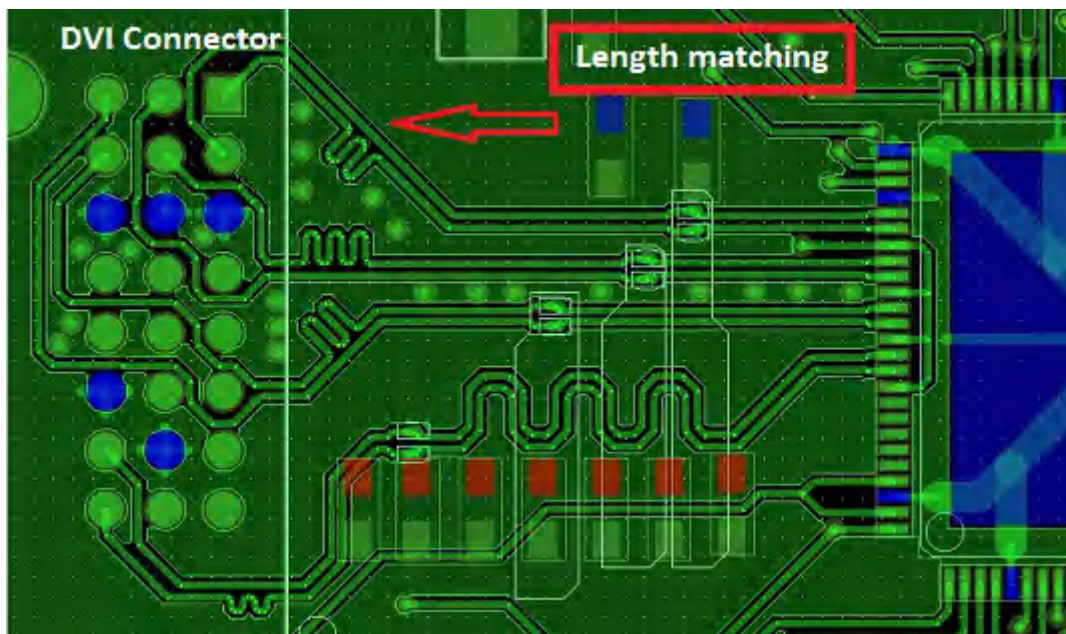

**Figure 7-7. DVI Signal Routing**

Keep the data lines as far as possible from each other as shown in [Figure 7-8](#).

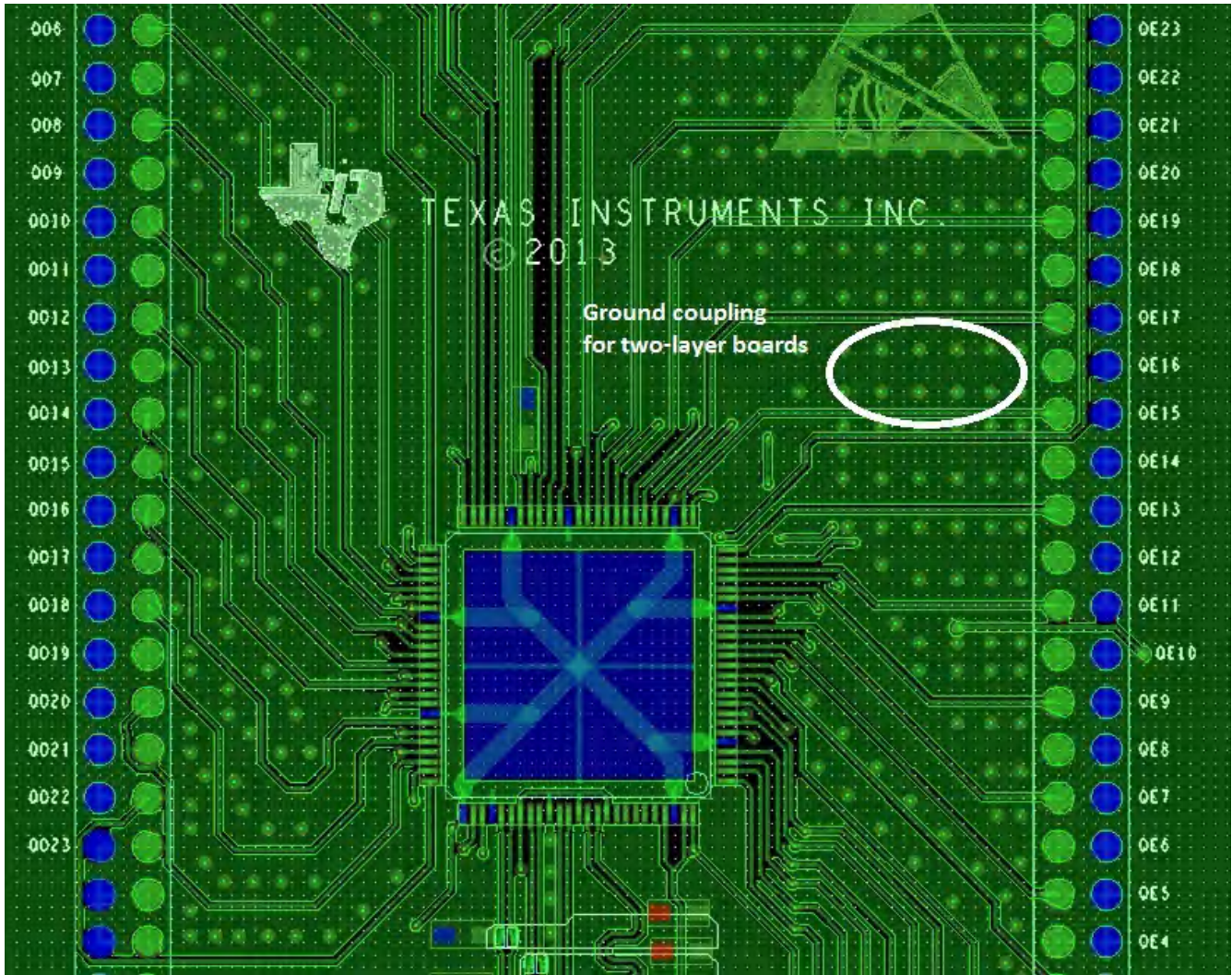
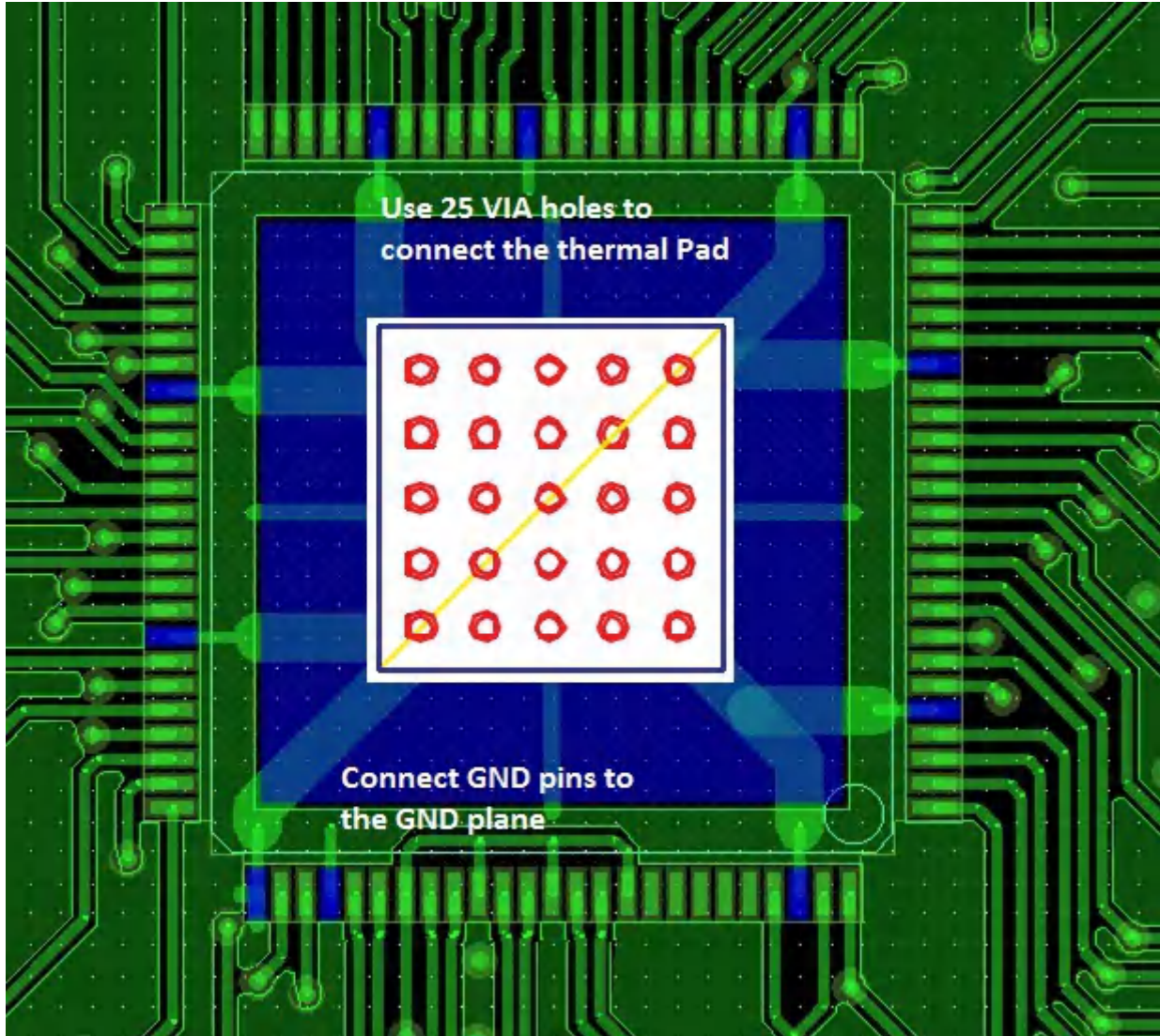

Figure 7-8. Data Signal Routing

Connect the thermal pad to ground as shown in [Figure 7-9](#).



**Figure 7-9. Ground Routing**

### 7.4.3 TI PowerPAD 64-Pin HTQFP Package

The TFP410 is available in TI's thermally enhanced 64-pin TQFP PowerPAD package. The PowerPAD package is a 10mm × 10mm × 1.0mm TQFP outline with 0.5mm lead-pitch. The PowerPAD package has a specially designed die mount pad that offers improved thermal capability over typical TQFP packages of the same outline. The TI 64-pin TQFP PowerPAD package offers a backside solder plane that connects directly to the die mount pad for enhanced thermal conduction. For thermal considerations, soldering the backside of the TFP410 to the application board is not required because the device power dissipation is well within the package capability when not soldered.

Soldering the backside of the device to the PCB ground plane is recommended for electrical considerations. Because the die pad is electrically connected to the chip substrate and hence chip ground, connecting the back side of the PowerPAD package to a PCG ground plane provides a low-inductance, low-impedance connection to help improve EMI, ground bounce, and power supply noise performance.

[Table 7-1](#) contains the thermal properties of the TI 64-pin TQFP PowerPAD package. The 64-pin TQFP non-PowerPAD package is included only for reference.

**Table 7-1. TI 64-Pin TQFP (10mm × 10mm × 1.0mm) / 0.5mm Lead-Pitch**

PARAMETER		WITHOUT PowerPAD™	PowerPAD™ NOT CONNECTED TO PCB THERMAL PLANE	PowerPAD™ CONNECTED TO PCB THERMAL PLANE <sup>(1)</sup>
R <sub>θJA</sub>	Thermal resistance, junction-to-ambient <sup>(1) (2)</sup>	75.83°C/W	42.20°C/W	21.47°C/W
R <sub>θJC</sub>	Thermal resistance, junction-to-case <sup>(1) (2)</sup>	7.80°C/W	0.38°C/W	0.38°C/W
P <sub>D</sub>	Power handling capabilities of package <sup>(1) (2) (3)</sup>	0.92 W	1.66 W	3.26 W

(1) Specified with the PowerPAD bond pad on the backside of the package soldered to a 2-oz. Cu plate PCB thermal plane.

(2) Airflow is at 0 LFM (no airflow)

(3) Specified at 150°C junction temperature and 80°C ambient temperature.

## 8 Device and Documentation Support

### 8.1 Receiving Notification of Documentation Updates

To receive notification of documentation updates, navigate to the device product folder on [ti.com](http://ti.com). Click on *Notifications* to register and receive a weekly digest of any product information that has changed. For change details, review the revision history included in any revised document.

### 8.2 Support Resources

[TI E2E™ support forums](#) are an engineer's go-to source for fast, verified answers and design help — straight from the experts. Search existing answers or ask your own question to get the quick design help you need.

Linked content is provided "AS IS" by the respective contributors. They do not constitute TI specifications and do not necessarily reflect TI's views; see TI's [Terms of Use](#).

### 8.3 Trademarks

Intel™ is a trademark of Intel Corporation.  
PowerPAD™, EPIC-5™, and PanelBus™ are trademarks of TI.  
Blu-ray™ is a trademark of Blu-ray Disc Association.  
TI E2E™ is a trademark of Texas Instruments.  
All trademarks are the property of their respective owners.

### 8.4 Electrostatic Discharge Caution



This integrated circuit can be damaged by ESD. Texas Instruments recommends that all integrated circuits be handled with appropriate precautions. Failure to observe proper handling and installation procedures can cause damage.

ESD damage can range from subtle performance degradation to complete device failure. Precision integrated circuits may be more susceptible to damage because very small parametric changes could cause the device not to meet its published specifications.

### 8.5 Glossary

[TI Glossary](#) This glossary lists and explains terms, acronyms, and definitions.

## 9 Revision History

NOTE: Page numbers for previous revisions may differ from page numbers in the current version.

Changes from Revision C (November 2014) to Revision D (February 2024)	Page
• Added inclusive terminology throughout the data sheet.....	1
• Changed pin 22 from: TVC + to: TXC+ .....	2
• Updated MSEN pin description from: <i>when I<sup>2</sup>C is disabled (ISEL = low), a low level indicates a powered on receiver is detected at the differential outputs. A high level indicates a powered on receiver is not detected to: when I<sup>2</sup>C is disabled (ISEL = low), a high level indicates a powered on receiver is detected at the differential outputs. A low level indicates a powered on receiver is not detected.</i> ....	2
• Changed pin 6 name from CTL3/A3/DK3 to A3/DK3.....	2
• Changed from: <i>When the I2C bus is disabled (ISEL = low) and the de-skew mode is disabled (DKEN = low), these three inputs become the control inputs, CTL[3:1], which can be used to send additional information across the DVI link during the blanking interval (DE = low). The CTL3 input is reserved for HDCP compliant DVI TXs (TFP510) and the CTL[2:1] inputs are reserved for future use.</i> to: <i>When the I<sup>2</sup>C bus is disabled (ISEL = low) and the de-skew mode is disabled (DKEN = low), pins 7 and 8 become the control inputs, CTL[2:1], which can be used to send additional information across the DVI link during the blanking interval (DE = low). Pin 6 is not used.</i> ....	2
• Updated V <sub>IH</sub> and V <sub>IL</sub> for Data, DE, VSYNC, HSYNC, and IDCK+/- CMOS inputs and the remaining CMOS inputs.....	7
• Changed <i>three user definable control signals, CTL[3:1], during the inactive display or blanking interval to: three control signals, CTL[3:1], during the inactive display or blanking interval</i> .....	11

• Changed the TFP410 encodes and transfers the CTL[3:1] inputs during the vertical blanking interval to: the TFP410 encodes and transfers the CTL[2:1] inputs during the vertical blanking interval .....	11
• Changed the CTL3 input is reserved for HDCP compliant DVI TXs and the CTL[2:1] inputs are reserved for future use to: CTL3 is reserved for HDCP and is always encoded as 0. The CTL[2:1] inputs are reserved for future use .....	11
• Changed RW field for sub-address 0B from RW to R. ....	18
• Changed CTL_1_MODE register reset value from: 0xFE to: 0xBE .....	20
• Changed in the CTL_3_MODE register, bit 3 from CTL3 to RSVD .....	21
• Added in DE_DLY register the value must be less than or equal to (2047 - DE_CNT) .....	22
• Added in the DE_CNT register the value must be less than or equal to (2047 - DE_DLY) .....	23
• Changed Application Information summary to be focused on TFP410 instead of the TDP401.....	25

<b>Changes from Revision B (May 2011) to Revision C (November 2014)</b>	<b>Page</b>
---	-------------

• Added ESD Ratings table, Thermal Information table, Typical Characteristics section, Feature Description section, Device Functional Modes, Application and Implementation section, Power Supply Recommendations section, Layout section, Device and Documentation Support section, and Mechanical, Packaging, and Orderable Information section. ....	1
---	---

## 10 Mechanical, Packaging, and Orderable Information

The following pages include mechanical, packaging, and orderable information. This information is the most current data available for the designated devices. This data is subject to change without notice and revision of this document. For browser-based versions of this data sheet, refer to the left-hand navigation.

**PACKAGING INFORMATION**

Orderable Device	Status (1)	Package Type	Package Drawing	Pins	Package Qty	Eco Plan (2)	Lead finish/ Ball material (6)	MSL Peak Temp (3)	Op Temp (°C)	Device Marking (4/5)	Samples
TFP410PAP	ACTIVE	HTQFP	PAP	64	160	RoHS & Green	NIPDAU	Level-3-260C-168 HR	0 to 70	TFP410PAP	<a href="#">Samples</a>
TFP410PAPG4	ACTIVE	HTQFP	PAP	64	160	RoHS & Green	NIPDAU	Level-3-260C-168 HR	0 to 70	TFP410PAP	<a href="#">Samples</a>
TFP410PAPR	ACTIVE	HTQFP	PAP	64	1000	RoHS & Green	NIPDAU	Level-3-260C-168 HR	0 to 70	TFP410PAP	<a href="#">Samples</a>

(1) The marketing status values are defined as follows:

**ACTIVE:** Product device recommended for new designs.

**LIFEBUY:** TI has announced that the device will be discontinued, and a lifetime-buy period is in effect.

**NRND:** Not recommended for new designs. Device is in production to support existing customers, but TI does not recommend using this part in a new design.

**PREVIEW:** Device has been announced but is not in production. Samples may or may not be available.

**OBsolete:** TI has discontinued the production of the device.

(2) **RoHS:** TI defines "RoHS" to mean semiconductor products that are compliant with the current EU RoHS requirements for all 10 RoHS substances, including the requirement that RoHS substance do not exceed 0.1% by weight in homogeneous materials. Where designed to be soldered at high temperatures, "RoHS" products are suitable for use in specified lead-free processes. TI may reference these types of products as "Pb-Free".

**RoHS Exempt:** TI defines "RoHS Exempt" to mean products that contain lead but are compliant with EU RoHS pursuant to a specific EU RoHS exemption.

**Green:** TI defines "Green" to mean the content of Chlorine (Cl) and Bromine (Br) based flame retardants meet JS709B low halogen requirements of <=1000ppm threshold. Antimony trioxide based flame retardants must also meet the <=1000ppm threshold requirement.

(3) MSL, Peak Temp. - The Moisture Sensitivity Level rating according to the JEDEC industry standard classifications, and peak solder temperature.

(4) There may be additional marking, which relates to the logo, the lot trace code information, or the environmental category on the device.

(5) Multiple Device Markings will be inside parentheses. Only one Device Marking contained in parentheses and separated by a "~" will appear on a device. If a line is indented then it is a continuation of the previous line and the two combined represent the entire Device Marking for that device.

(6) Lead finish/Ball material - Orderable Devices may have multiple material finish options. Finish options are separated by a vertical ruled line. Lead finish/Ball material values may wrap to two lines if the finish value exceeds the maximum column width.

**Important Information and Disclaimer:**The information provided on this page represents TI's knowledge and belief as of the date that it is provided. TI bases its knowledge and belief on information provided by third parties, and makes no representation or warranty as to the accuracy of such information. Efforts are underway to better integrate information from third parties. TI has taken and continues to take reasonable steps to provide representative and accurate information but may not have conducted destructive testing or chemical analysis on incoming materials and chemicals. TI and TI suppliers consider certain information to be proprietary, and thus CAS numbers and other limited information may not be available for release.

In no event shall TI's liability arising out of such information exceed the total purchase price of the TI part(s) at issue in this document sold by TI to Customer on an annual basis.

**OTHER QUALIFIED VERSIONS OF TFP410 :**

- Enhanced Product : [TFP410-EP](#)

NOTE: Qualified Version Definitions:

- Enhanced Product - Supports Defense, Aerospace and Medical Applications

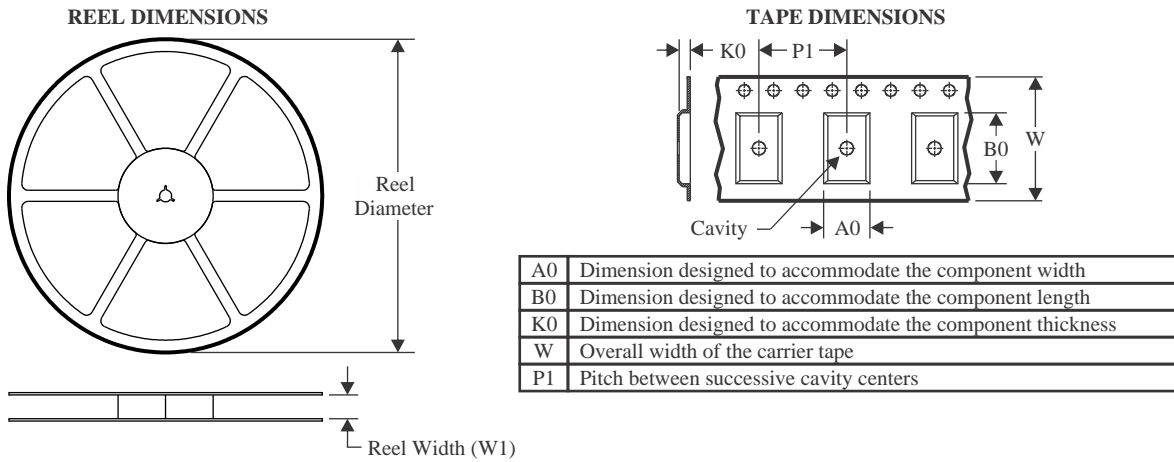
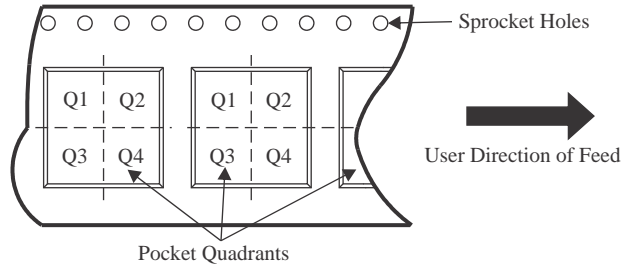
**TAPE AND REEL INFORMATION**

**QUADRANT ASSIGNMENTS FOR PIN 1 ORIENTATION IN TAPE**

\*All dimensions are nominal

Device	Package Type	Package Drawing	Pins	SPQ	Reel Diameter (mm)	Reel Width W1 (mm)	A0 (mm)	B0 (mm)	K0 (mm)	P1 (mm)	W (mm)	Pin1 Quadrant
TFP410PAPR	HTQFP	PAP	64	1000	330.0	24.4	13.0	13.0	1.5	16.0	24.0	Q2

**TAPE AND REEL BOX DIMENSIONS**

\*All dimensions are nominal

Device	Package Type	Package Drawing	Pins	SPQ	Length (mm)	Width (mm)	Height (mm)
TFP410PAPR	HTQFP	PAP	64	1000	350.0	350.0	43.0

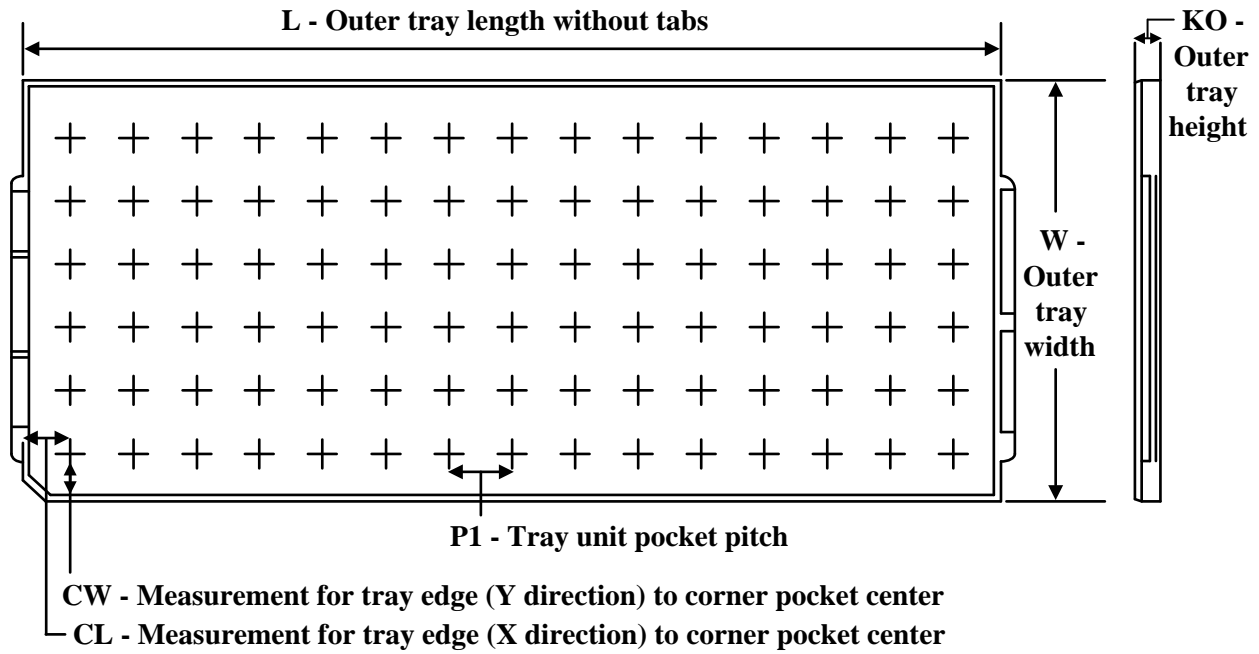
**TRAY**

Chamfer on Tray corner indicates Pin 1 orientation of packed units.

\*All dimensions are nominal

Device	Package Name	Package Type	Pins	SPQ	Unit array matrix	Max temperature (°C)	L (mm)	W (mm)	K0 (μm)	P1 (mm)	CL (mm)	CW (mm)
TFP410PAP	PAP	HTQFP	64	160	8 x 20	150	315	135.9	7620	15.2	13.1	13
TFP410PAPG4	PAP	HTQFP	64	160	8 x 20	150	315	135.9	7620	15.2	13.1	13

## GENERIC PACKAGE VIEW

**PAP 64**

**HTQFP - 1.2 mm max height**

10 x 10, 0.5 mm pitch

QUAD FLATPACK

This image is a representation of the package family, actual package may vary.  
Refer to the product data sheet for package details.

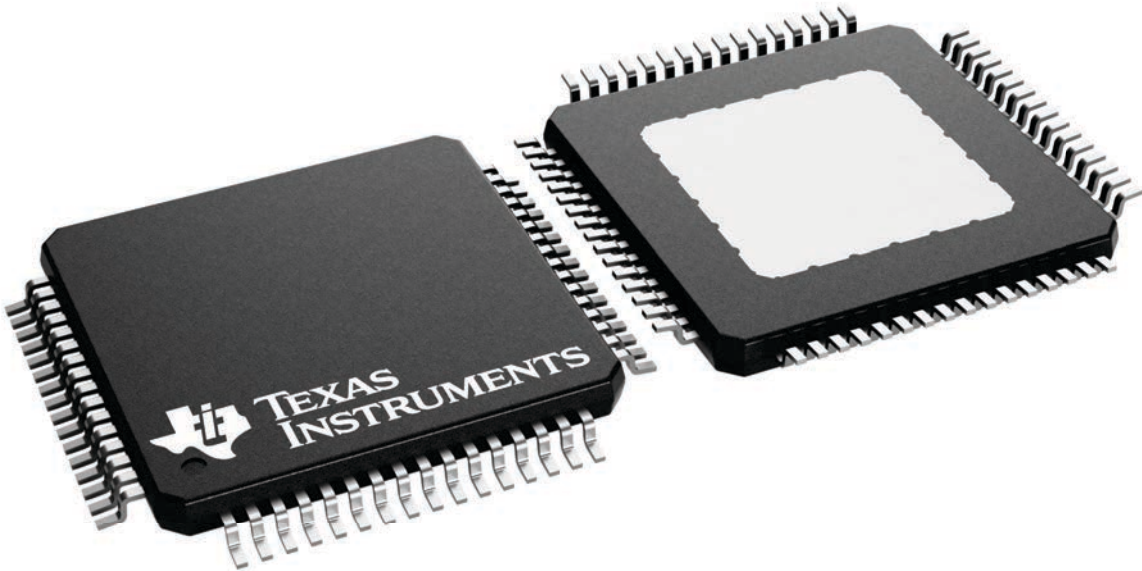

4226442/A

PAP (S-PQFP-G64)

PowerPAD™ PLASTIC QUAD FLATPACK

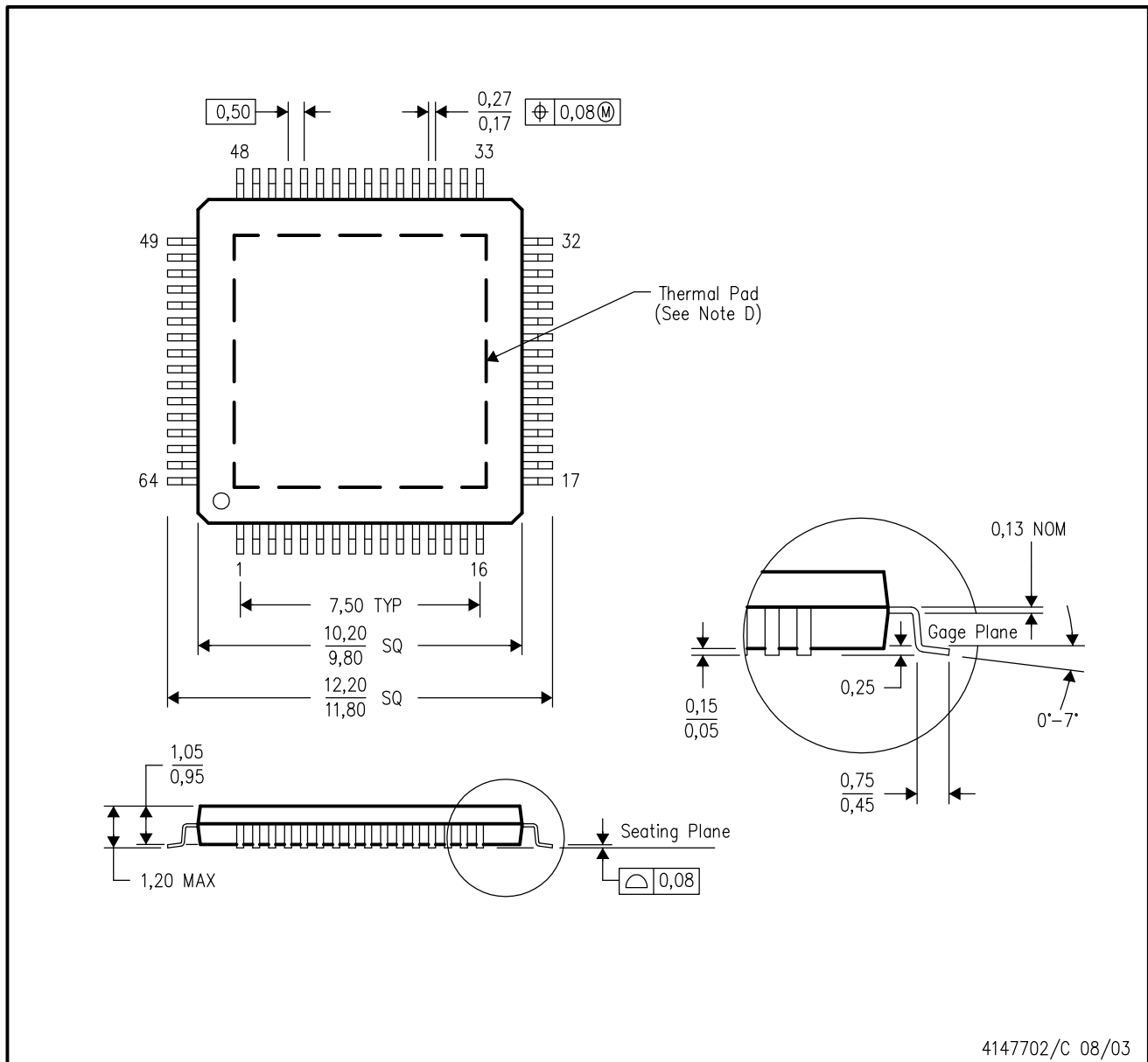

4147702/C 08/03

- NOTES:
- A. All linear dimensions are in millimeters.
  - B. This drawing is subject to change without notice.
  - C. Body dimensions do not include mold flash or protrusion
  - D. This package is designed to be soldered to a thermal pad on the board. Refer to Technical Brief, PowerPad Thermally Enhanced Package, Texas Instruments Literature No. SLMA002 for information regarding recommended board layout. This document is available at [www.ti.com](http://www.ti.com) <<http://www.ti.com>>.
  - E. Falls within JEDEC MS-026

PowerPAD is a trademark of Texas Instruments.

## THERMAL PAD MECHANICAL DATA

PAP (S-PQFP-G64)

PowerPAD™ PLASTIC QUAD FLATPACK

### THERMAL INFORMATION

This PowerPAD™ package incorporates an exposed thermal pad that is designed to be attached to a printed circuit board (PCB). The thermal pad must be soldered directly to the PCB. After soldering, the PCB can be used as a heatsink. In addition, through the use of thermal vias, the thermal pad can be attached directly to the appropriate copper plane shown in the electrical schematic for the device, or alternatively, can be attached to a special heatsink structure designed into the PCB. This design optimizes the heat transfer from the integrated circuit (IC).

For additional information on the PowerPAD package and how to take advantage of its heat dissipating abilities, refer to Technical Brief, PowerPAD Thermally Enhanced Package, Texas Instruments Literature No. SLMA002 and Application Brief, PowerPAD Made Easy, Texas Instruments Literature No. SLMA004. Both documents are available at [www.ti.com](http://www.ti.com).

The exposed thermal pad dimensions for this package are shown in the following illustration.

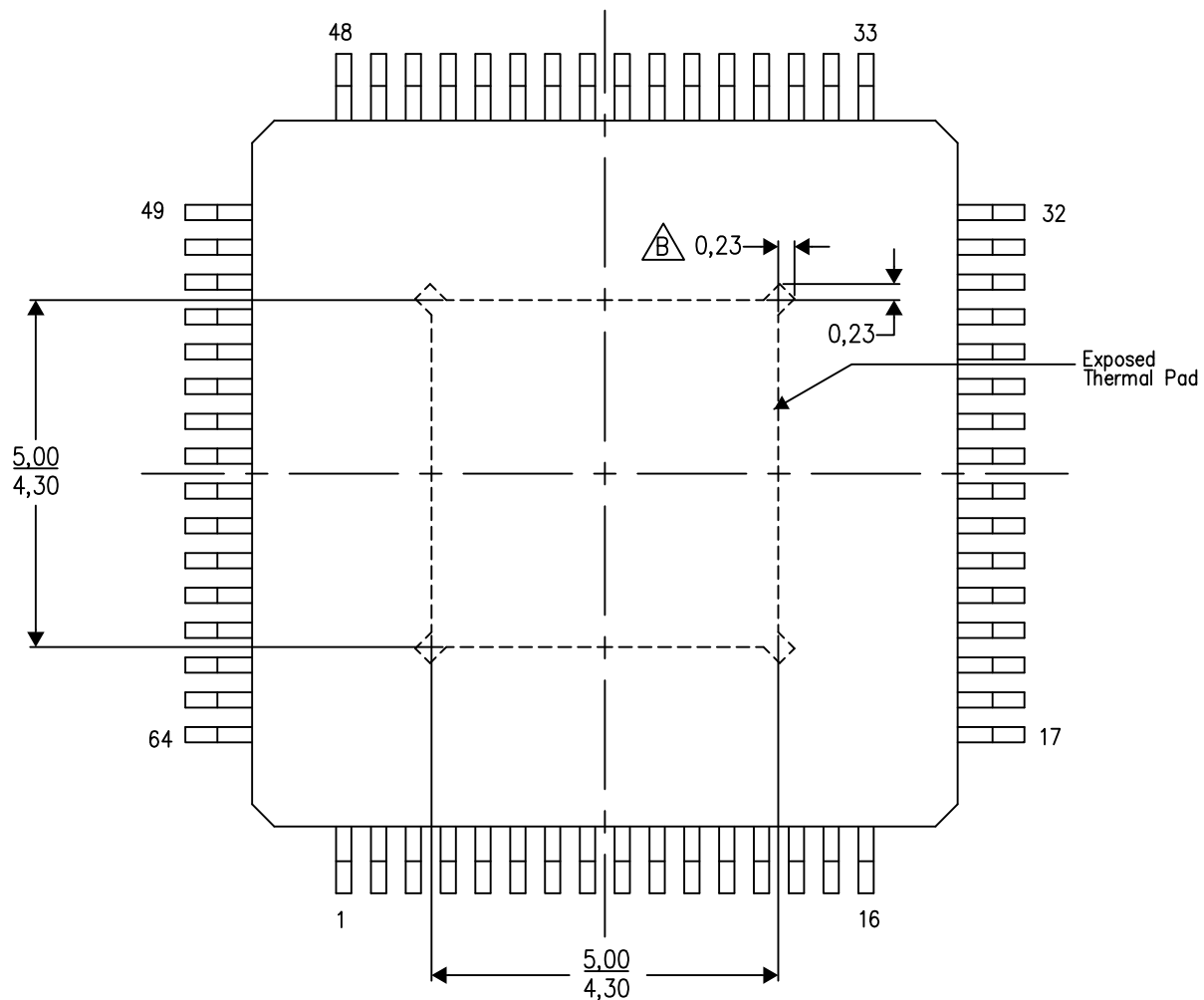

4206326-3/P 05/14

NOTES: A. All linear dimensions are in millimeters

 Tie strap features may not be present.

PowerPAD is a trademark of Texas Instruments

# LAND PATTERN DATA

PAP (S-PQFP-G64)

PowerPAD™ PLASTIC QUAD FLATPACK

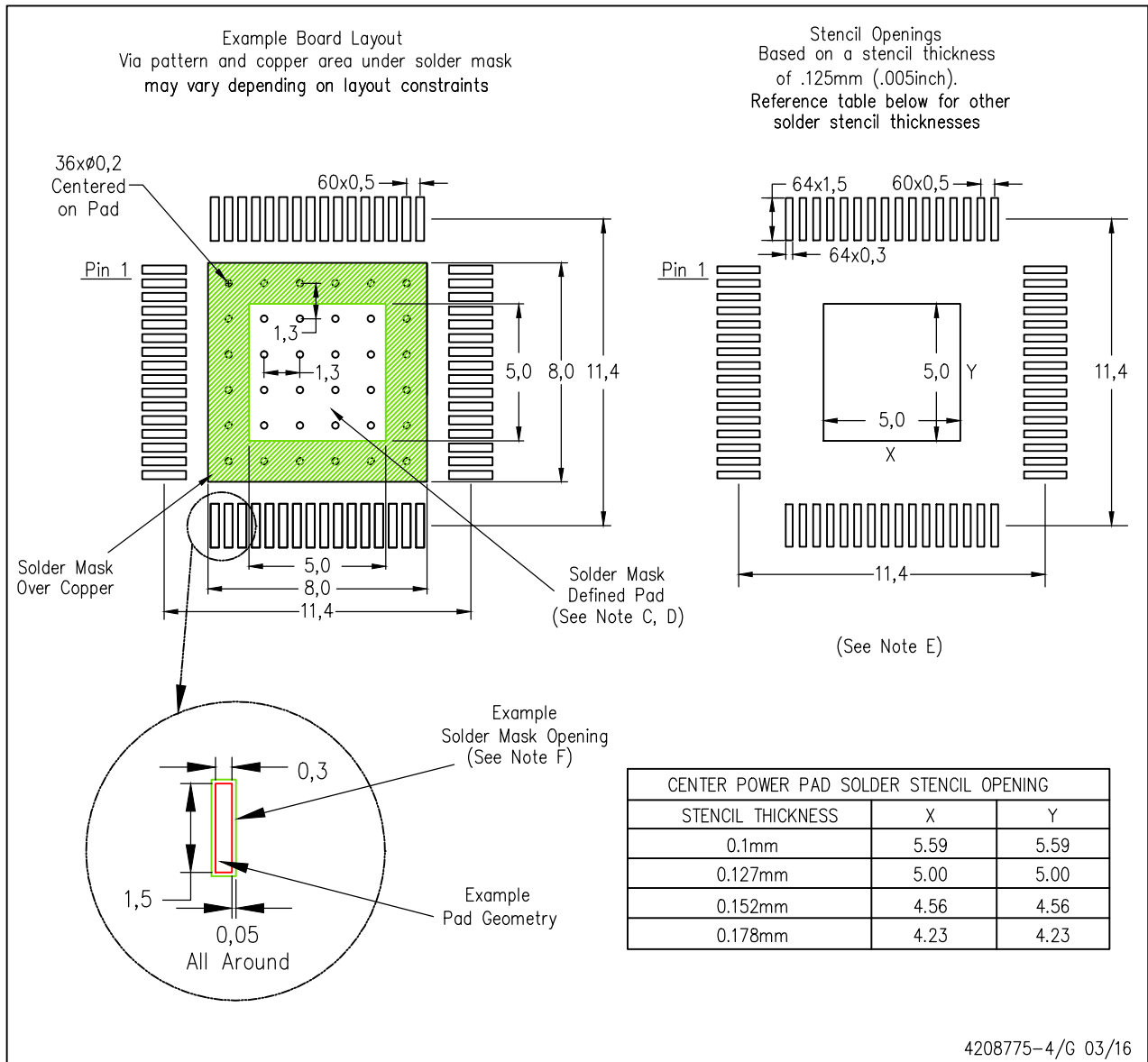

- NOTES:
- A. All linear dimensions are in millimeters.
  - B. This drawing is subject to change without notice.
  - C. Customers should place a note on the circuit board fabrication drawing not to alter the center solder mask defined pad.
  - D. This package is designed to be soldered to a thermal pad on the board. Refer to Technical Brief, PowerPad Thermally Enhanced Package, Texas Instruments Literature No. SLMA002, SLMA004, and also the Product Data Sheets for specific thermal information, via requirements, and recommended board layout. These documents are available at [www.ti.com](http://www.ti.com) <<http://www.ti.com>>. Publication IPC-7351 is recommended for alternate designs.
  - E. Laser cutting apertures with trapezoidal walls and also rounding corners will offer better paste release. Customers should contact their board assembly site for stencil design recommendations. Example stencil design based on a 50% volumetric metal load solder paste. Refer to IPC-7525 for other stencil recommendations.
  - F. Customers should contact their board fabrication site for solder mask tolerances between and around signal pads.
- PowerPAD is a trademark of Texas Instruments**

## IMPORTANT NOTICE AND DISCLAIMER

TI PROVIDES TECHNICAL AND RELIABILITY DATA (INCLUDING DATA SHEETS), DESIGN RESOURCES (INCLUDING REFERENCE DESIGNS), APPLICATION OR OTHER DESIGN ADVICE, WEB TOOLS, SAFETY INFORMATION, AND OTHER RESOURCES "AS IS" AND WITH ALL FAULTS, AND DISCLAIMS ALL WARRANTIES, EXPRESS AND IMPLIED, INCLUDING WITHOUT LIMITATION ANY IMPLIED WARRANTIES OF MERCHANTABILITY, FITNESS FOR A PARTICULAR PURPOSE OR NON-INFRINGEMENT OF THIRD PARTY INTELLECTUAL PROPERTY RIGHTS.

These resources are intended for skilled developers designing with TI products. You are solely responsible for (1) selecting the appropriate TI products for your application, (2) designing, validating and testing your application, and (3) ensuring your application meets applicable standards, and any other safety, security, regulatory or other requirements.

These resources are subject to change without notice. TI grants you permission to use these resources only for development of an application that uses the TI products described in the resource. Other reproduction and display of these resources is prohibited. No license is granted to any other TI intellectual property right or to any third party intellectual property right. TI disclaims responsibility for, and you will fully indemnify TI and its representatives against, any claims, damages, costs, losses, and liabilities arising out of your use of these resources.

TI's products are provided subject to [TI's Terms of Sale](#) or other applicable terms available either on [ti.com](https://www.ti.com) or provided in conjunction with such TI products. TI's provision of these resources does not expand or otherwise alter TI's applicable warranties or warranty disclaimers for TI products.

TI objects to and rejects any additional or different terms you may have proposed.

Mailing Address: Texas Instruments, Post Office Box 655303, Dallas, Texas 75265  
Copyright © 2024, Texas Instruments Incorporated

## Looking for pricing, stock, or lifecycle information?

Click below to explore more details on WIN SOURCE:

 [View TFP410PAP](#) on WIN SOURCE

 [Texas Instruments](#) Information

## Optimize Your Supply Chain with WIN SOURCE Solutions

-  Global Sourcing Solution
-  Obsolete Management
-  Cost Control Management
-  Shortage Management
-  Alternative Solution
-  Excess Inventory Management