



**THE DATASHEET OF
TFP101PZP**



- Supports XGA Resolution (Output Pixel Rates Up to 86 MHz)
- Digital Visual Interface (DVI) Specification Compliant¹
- True-Color, 24 Bit/Pixel, 16.7M Colors at 1 or 2-Pixels Per Clock
- Laser Trimmed Internal Termination Resistors for Optimum Fixed Impedance Matching
- Skew Tolerant Up to One Pixel Clock Cycle
- 4x Over-Sampling
- Reduced Power Consumption – 1.8 V Core Operation With 3.3 V I/Os and Supplies²
- Reduced Ground Bounce Using Time Staggered Pixel Outputs
- Lowest Noise and Best Power Dissipation Using TI PowerPAD™ Packaging
- Advanced Technology Using TI 0.18-μm EPIC-5™ CMOS Process
- TFP101A Incorporates HSYNC Jitter Immunity³

description

The Texas Instruments TFP101 and TFP101A are TI *PanelBus*™ flat panel display products, part of a comprehensive family of end-to-end DVI 1.0 compliant solutions. Targeted primarily at desktop LCD monitors and digital projectors, the TFP101/101A finds applications in any design requiring high-speed digital interface.

The TFP101/101A supports display resolutions up to XGA in 24-bit true color pixel format. The TFP101/101A offers design flexibility to drive one or two pixels per clock, supports TFT or DSTN panels, and provides an option for time staggered pixel outputs for reduced ground bounce.

PowerPAD™ advanced packaging technology results in best of class power dissipation, footprint, and ultra-low ground inductance.

The TFP101/101A combines *PanelBus*™ circuit innovation with TI's advanced 0.18-μm EPIC-5™ CMOS process technology, along with TI PowerPAD™ package technology to achieve a reliable, low-powered, low noise, high-speed digital interface solution.

AVAILABLE OPTIONS

T _A	PACKAGED DEVICE
	0°C to 70°C
TFP101PZP	
TFP101APZP	



Please be aware that an important notice concerning availability, standard warranty, and use in critical applications of Texas Instruments semiconductor products and disclaimers thereto appears at the end of this data sheet.

1. The Digital Visual Interface Specification, DVI, is an industry standard developed by the Digital Display Working Group (DDWG) for high-speed digital connection to digital displays. The TFP101 and TFP101A are compliant to the DVI Specification Rev. 1.0.
2. The TFP101/101A has an internal voltage regulator that provides the 1.8-V core power supply from the externally supplied 3.3-V supplies.
3. The TFP101A incorporates additional circuitry to create a stable HSYNC from DVI transmitters that introduce undesirable jitter on the transmitted HSYNC signal.

PanelBus, PowerPAD and EPIC-5 are trademarks of Texas Instruments.

I²C is a licensed bus protocol from Phillips Semiconductor, Inc.

PRODUCTION DATA information is current as of publication date. Products conform to specifications per the terms of Texas Instruments standard warranty. Production processing does not necessarily include testing of all parameters.



functional block diagram

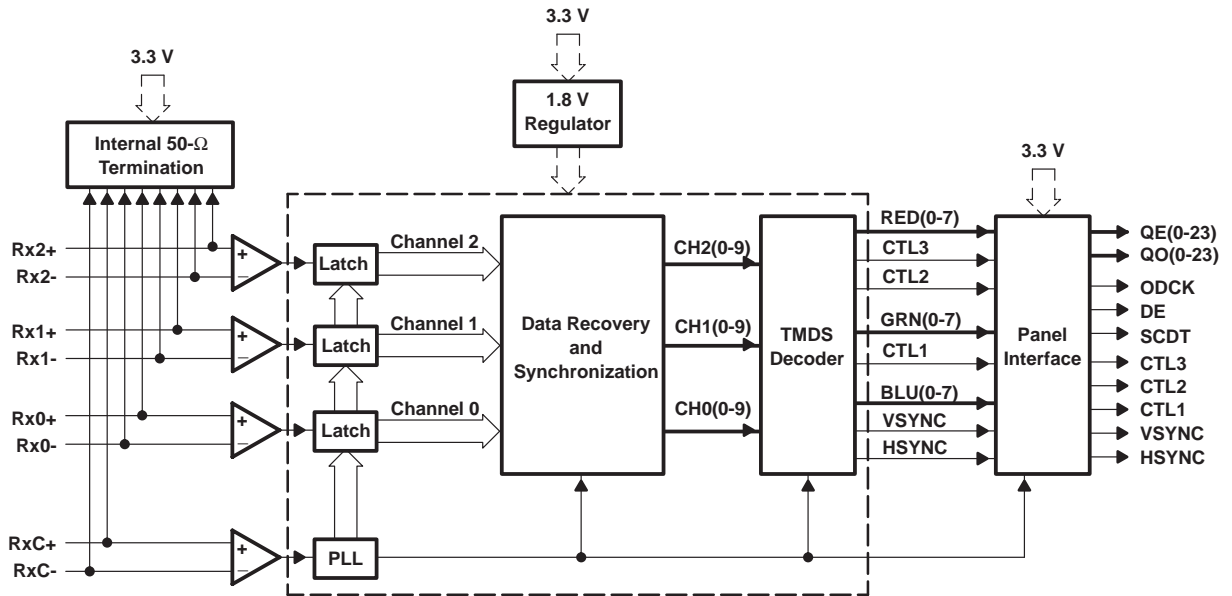

Terminal Functions

TERMINAL NAME	NO.	I/O	DESCRIPTION
AGND	79,83,87, 89,92	GND	Analog Ground – Ground reference and current return for analog circuitry.
AV _{DD}	82,84,88, 95	V _{DD}	Analog V _{DD} – Power supply for analog circuitry. Nominally 3.3 V
CTL[3:1]	42,41,40	DO	General-purpose control signals – Used for user defined control. CTL1 is not powered-down via $\overline{\text{PDO}}$.
DE	46	DO	Output data enable – Used to indicate time of active video display versus non-active display or blank time. During blank, only HSYNC, VSYNC, and CTL1-3 are transmitted. During times of active display, or non-blank, only pixel data, QE[23:0] and QO[23:0], is transmitted. High : Active display time Low: Blank time
DFO	1	DI	Output clock data format – Controls the output clock (ODCK) format for either TFT or DSTN panel support. For TFT support ODCK clock runs continuously. For DSTN support ODCK only clocks when DE is high, otherwise ODCK is held low when DE is low. High : DSTN support/ODCK held low when DE = low Low: TFT support/ODCK runs continuously.
DGND	5,39,68	GND	Digital ground – Ground reference and current return for digital core
DV _{DD}	6,38,67	V _{DD}	Digital V _{DD} – Power supply for digital core. Nominally 3.3 V
EXT_RES	96	AI	Internal impedance matching – The TFP101/101A is internally optimized for impedance matching at 50 Ω . An external resistor tied to this pin will have no effect on device performance.
HSYNC	48	DO	Horizontal sync output
RSVD	99	DI	Reserved. Must be tied high for normal operation.
OV _{DD}	18,29,43, 57,78	V _{DD}	Output driver V _{DD} – Power supply for output drivers. Nominally 3.3 V
ODCK	44	DO	Output data clock - Pixel clock. All pixel outputs QE[23:0] and QO[23:0] (if in 2-pixel/clock mode) along with DE, HSYNC, VSYNC and CTL[3:1] are synchronized to this clock.

TFP101, TFP101A

TI PanelBus™ DIGITAL RECEIVER

SLDS119C - MARCH 2000 – REVISED OCTOBER 2003

Terminal Functions (continued)

TERMINAL NAME	NO.	I/O	DESCRIPTION
OGND	19,28,45,58,76	GND	Output driver ground – Ground reference and current return for digital output drivers
OCK_INV	100	DI	ODCK Polarity – Selects ODCK edge on which pixel data (QE[23:0] and QO[23:0]) and control signals (HSYNC, VSYNC, DE, CTL1-3) are latched Normal Mode: High : Latches output data on rising ODCK edge Low : Latches output data on falling ODCK edge
PD	2	DI	Power down – An active low signal that controls the TFP101/101A power-down state. During power down all output buffers are switched to a high impedance state. All analog circuits are powered down and all inputs are disabled, except for PD. If \overline{PD} is left unconnected an internal pullup will default the TFP101/101A to normal operation. High : Normal operation Low: Power down
PDO	9	DI	Output drive power down – An active low signal that controls the power-down state of the output drivers. During output drive power down, the output drivers (except SCDT and CTL1) are driven to a high impedance state. When \overline{PDO} is left unconnected, an internal pullup defaults the TFP101/101A to normal operation. High : Normal operation/output drivers on Low: Output drive power down.
PGND	98	GND	PLL GND – Ground reference and current return for internal PLL
PIXS	4	DI	Pixel select – Selects between one or two pixels per clock output modes. During the 2-pixel/clock mode, both even pixels, QE[23:0], and odd pixels, QO[23:0], are output in tandem on a given clock cycle. During 1-pixel/clock, even and odd pixels are output sequentially, one at a time, with the even pixel first, on the even pixel bus, QE[23:0]. (The first pixel per line is pixel-0, the even pixel. The second pixel per line is pixel-1, the odd pixel.) High : 2-pixel/clock Low: 1-pixel/clock
PVDD	97	VDD	PLL VDD – Power supply for internal PLL
QE[0:7]	10-17	DO	Even blue pixel output – Output for even and odd blue pixels when in 1-pixel/clock mode. Output for even only blue pixel when in 2-pixel per clock mode. Output data is synchronized to the output data clock, ODCK. LSB: QE0/pin 10 MSB: QE7/pin 17
QE[8:15]	20-27	DO	Even green pixel output – Output for even and odd green pixels when in 1-pixel/clock mode. Output for even only green pixel when in 2-pixel/clock mode. Output data is synchronized to the output data clock, ODCK. LSB: QE8/pin 20 MSB: QE15/pin 27
QE[16:23]	30-37	DO	Even red pixel output – Output for even and odd red pixels when in 1-pixel/clock mode. Output for even only red pixel when in 2-pixel/clock mode. Output data is synchronized to the output data clock, ODCK. LSB: QE16/pin 30 MSB: QE23/pin 37
QO[0:7]	49-56	DO	Odd blue pixel output – Output for odd only blue pixel when in 2-pixel/clock mode. Not used, and held low, when in 1-pixel/clock mode. Output data is synchronized to the output data clock, ODCK. LSB: QO0/pin 49 MSB: QO7/pin 56
QO[8:15]	59-66	DO	Odd green pixel output – Output for odd only green pixel when in 2-pixel/clock mode. Not used, and held low, when in 1-pixel/clock mode. Output data is synchronized to the output data clock, ODCK. LSB: QO8/pin 59 MSB: QO15/pin 66
QO[16:23]	69-75,77	DO	Odd red pixel output – Output for odd only red pixel when in 2-pixel/clock mode. Not used, and held low, when in 1-pixel/clock mode. Output data is synchronized to the output data clock, ODCK. LSB: QO16/pin 69 MSB: QO23/pin 77



Terminal Functions (continued)

TERMINAL		I/O	DESCRIPTION
NAME	NO.		
RxC+	93	AI	Clock positive receiver input – Positive side of reference clock. TMDS low voltage signal differential input pair.
RxC–	94	AI	Clock negative receiver input – Negative side of reference clock. TMDS low voltage signal differential input pair.
Rx0+	90	AI	Channel-0 positive receiver input – Positive side of channel-0. TMDS low voltage signal differential input pair. Channel-0 receives blue pixel data in active display and HSYNC, VSYNC control signals in blank.
Rx0–	91	AI	Channel-0 negative receiver input – Negative side of channel-0. TMDS low voltage signal differential input pair.
Rx1+	85	AI	Channel-1 positive receiver input – Positive side of channel-1 TMDS low voltage signal differential input pair. Channel-1 receives green pixel data in active display and CTL1 control signals in blank.
Rx1–	86	AI	Channel-1 negative receiver input – Negative side of channel-1 TMDS low voltage signal differential input pair.
Rx2+	80	AI	Channel-2 positive receiver input – Positive side of channel-2 TMDS low voltage signal differential input pair. Channel-2 receives red pixel data in active display and CTL2, CTL3 control signals in blank.
Rx2–	81	AI	Channel-2 negative receiver input – Negative side of channel-2 TMDS low voltage signal differential input pair.
SCDT	8	DO	Sync detect – Output to signal when the link is active or inactive. The link is considered to be active when DE is actively switching. The TFP101/101A monitors the state DE to determine link activity. SCDT can be tied externally to PDO to power down the output drivers when the link is inactive. High: Active link Low: Inactive link
ST	3	DI	Output drive strength select – Selects output drive strength for high or low current drive. (See dc specifications for I_{OH} and I_{OL} vs ST state.) High : High drive strength Low : Low drive strength
STAG	7	DI	Staggered pixel select – An active low signal used in the 2-pixel/clock pixel mode (PIXS = high). Time staggers the even and odd pixel outputs to reduce ground bounce. Normal operation outputs the odd and even pixels simultaneously. High : Normal simultaneous even/odd pixel output Low: Time staggered even/odd pixel output
VSYNC	47	DO	Vertical sync output

absolute maximum ratings over operating free-air temperature (unless otherwise noted)†

Supply voltage range, DV_{DD} , AV_{DD} , OV_{DD} , PV_{DD}	-0.3 V to 4 V
Input voltage range, logic/analog signals	-0.3 V to 4 V
Operating ambient temperature range	0°C to 70°C
Storage temperature range	-65°C to 150°C
Case temperature for 10 seconds	260°C
Lead temperature 1,6 mm (1/16 inch) from case for 10 seconds	260°C
Package power dissipation/PowerPAD™: Soldered (see Note 1)	4.3 W
Not soldered (see Note 2)	2.7 W
ESD Protection, all pins	2.5 KV Human Body Model
JEDEC latchup (EIA/JESD78)	100 mA

† Stresses beyond those listed under “absolute maximum ratings” may cause permanent damage to the device. These are stress ratings only, and functional operation of the device at these or any other conditions beyond those indicated under “recommended operating conditions” is not implied. Exposure to absolute-maximum-rated conditions for extended periods may affect device reliability.

- NOTES: 1. Specified with PowerPAD™ bond pad on the backside of the package soldered to a 2 oz. Cu plate PCB thermal plane. Specified at maximum allowed operating temperature, 70°C.
2. PowerPAD™ bond pad on the backside of the package is not soldered to a thermal plane. Specified at maximum allowed operating temperature, 70°C.

TFP101, TFP101A

TI PanelBus™ DIGITAL RECEIVER

SLDS119C - MARCH 2000 – REVISED OCTOBER 2003

recommended operating conditions

	MIN	TYP	MAX	UNIT
Supply voltage, V_{DD} (DV_{DD} , AV_{DD} , PV_{DD} , OV_{DD})	3	3.3	3.6	V
Pixel time, t_{pix} †	11.6		40	ns
Single ended analog input termination resistance, R_t	45	50	55	Ω
Operating free-air temperature, T_A	0	25	70	°C

† t_{pix} is the pixel time defined as the period of the RxC clock input. The period of the output clock, ODCK is equal to t_{pix} when in 1-pixel/clock mode and $2t_{pix}$ when in 2-pixel/clock mode.

electrical characteristics over recommended operating free-air temperature range (unless otherwise noted)

dc digital I/O specifications

PARAMETER	TEST CONDITIONS	MIN	TYP	MAX	UNIT
V_{IH} High level digital input voltage‡		2		DV_{DD}	V
V_{IL} Low level digital input voltage‡		0		0.8	V
I_{OH} High level output drive current§	ST = High, $V_{OH} = 2.4$ V	5	10	14	mA
	ST = Low, $V_{OH} = 2.4$ V	3	6	9	
I_{OL} Low level output drive current§	ST = High, $V_{OL} = 0.8$ V	10	13	19	mA
	ST = Low, $V_{OL} = 0.8$ V	5	7	11	
I_{OZ} Hi-Z output leakage current	$\overline{PD} = \text{Low}$ or $\overline{PDO} = \text{Low}$	-1		1	μA

‡ Digital inputs are labeled DI in I/O column of Terminal Functions Table.

§ Digital outputs are labeled DO in I/O column of Terminal Functions Table.

dc specifications

PARAMETER	TEST CONDITIONS	MIN	TYP	MAX	UNIT
V_{ID} Analog input differential voltage (see Note 3)		75		1200	mv
V_{IC} Analog input common mode voltage (see Note 3)		$AV_{DD}-300$		$AV_{DD}-37$	mv
$V_{I(OC)}$ Open circuit analog input voltage		$AV_{DD}-10$		$AV_{DD}+10$	mv
$I_{DD(2PIX)}$ Normal 2-pix/clock power supply current (see Note 4)	ODCK = 43 MHz 2-pix/clock			350	mA
I_{PD} Power down current (see Note 5)	$\overline{PD} = \text{Low}$			10	mA
I_{PDO} Output drive power down current (see Note 5)	$\overline{PDO} = \text{Low}$		35		mA

NOTES: 3. Specified as dc characteristic with no overshoot or undershoot.

4. Alternating 2-pixel black/2-pixel white pattern. ST = high, $\overline{STAG} = \text{high}$, QE[23:0] and QO[23:0] $C_L = 10$ pF.

5. Analog inputs are open circuit (transmitter is disconnected from TFP101/101A).



electrical characteristics over recommended operating free-air temperature range (unless otherwise noted) (continued)

ac specifications

PARAMETER		TEST CONDITIONS	MIN	TYP	MAX	UNIT
V _{ID(2)}	Differential input sensitivity†		150		1560	mV _{p-p}
t _{ps}	Analog input intra-pair (+ to -) differential skew (see Note 6)				0.4	t _{bit} ‡
t _{ccs}	Analog Input inter-pair or channel-to-channel skew (see Note 6)				1	t _{pix} §
t _{jjit}	Worse case differential input clock jitter tolerance¶	(see Note 6)	50			ps
t _{f1}	Fall time of data and control signals#,	ST = Low, C _L =5 pF ST = High, C _L =10 pF			2.4 1.9	ns
t _{r1}	Rise time of data and control signals#,	ST = Low, C _L =5 pF ST = High, C _L =10 pF			2.4 1.9	ns
t _{r2}	Rise time of ODCK clock#	ST = Low, C _L =5 pF ST = High, C _L =10 pF			2.4 1.9	ns
t _{f2}	Fall time of ODCK clock#	ST = Low, C _L =5 pF ST = High, C _L =10 pF			2.4 1.9	ns
t _{su1}	Setup time, data and control signal to falling edge of ODCK (OCK_INV = low)	ST = Low, C _L =5 pF ST = High, C _L =10 pF	3.6			ns
t _{h1}	Hold time, data and control signal to falling edge of ODCK (OCK_INV = low)	ST = Low, C _L =5 pF ST = High, C _L =10 pF	3.6			ns
t _{su2}	Setup time, data and control signal to rising edge of ODCK (OCK_INV = high)	ST = Low, C _L =5 pF ST = High, C _L =10 pF	3.6			ns
t _{h2}	Hold time, data and control signal to rising edge of ODCK (OCK_INV = high)	ST = Low, C _L =5 pF ST = High, C _L =10 pF	3.1			ns
f _{ODCK}	ODCK frequency	PIX = Low (1-PIX/CLK)	25		86	MHz
		PIX = High (2-PIX/CLK)	12.5		43	
	ODCK duty-cycle		40%	50%	60%	
t _{pd(PDL)}	Propagation delay time from $\overline{\text{PD}}$ low to Hi-Z outputs				9	ns
t _{pd(PDOL)}	Propagation delay time from $\overline{\text{PDO}}$ low to Hi-Z outputs				9	ns
t _{t(HSC)}	Transition time between DE transition to SCDT low*			1e6		t _{pix}
t _{t(FSC)}	Transition time between DE transition to SCDT high*			1024		t _{pix}
t _{d(st)}	Delay time, ODCK latching edge to QE[23:0] data output	$\overline{\text{STAG}}$ = Low Pixs = High		0.25		t _{pix}

† Specified as ac parameter to include sensitivity to overshoot, undershoot and reflection.

‡ t_{bit} is 1/10 the pixel time, t_{pix}

§ t_{pix} is the pixel time defined as the period of the RxC input clock. The period of ODCK is equal to t_{pix} in 1-pixel/clock mode or 2t_{pix} when in 2-pixel/clock mode.

¶ Measured differentially at 50% crossing using ODCK output clock as trigger.

Rise and fall times measured as time between 20% and 80% of signal amplitude.

|| Data and control signals are : QE[23:0], QO[23:0], DE, HSYNC, VSYNC and CTL[3:1]

*Link active or inactive is determined by amount of time detected between DE transitions. SCDT indicates link activity.

NOTE 6: By characterization

PARAMETER MEASUREMENT INFORMATION

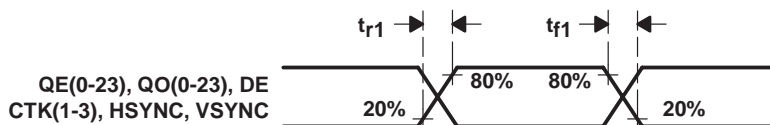

Figure 1. Rise and Fall Time of Data and Control Signals

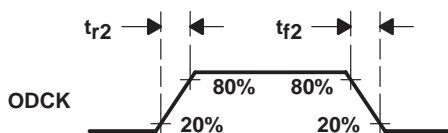

Figure 2. Rise and Fall Time of ODCK



Figure 3. ODCK Frequency

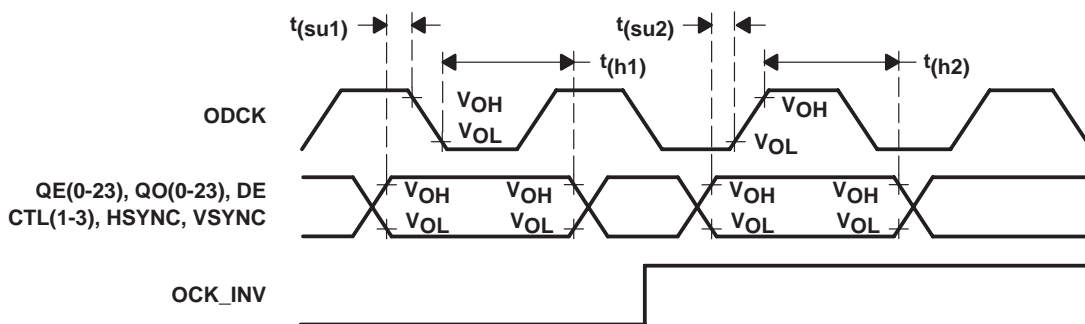

Figure 4. Data Setup and Hold Time to Rising and Falling Edge of ODCK

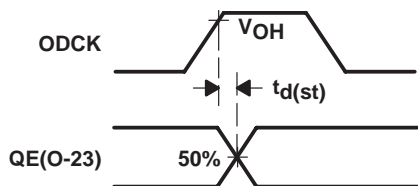

Figure 5. ODCK High to QE[23:0] Staggered Data Output

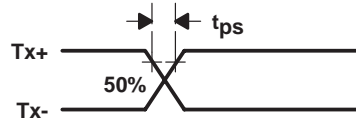

Figure 6. Analog Input Intra-Pair Differential Skew

PARAMETER MEASUREMENT INFORMATION

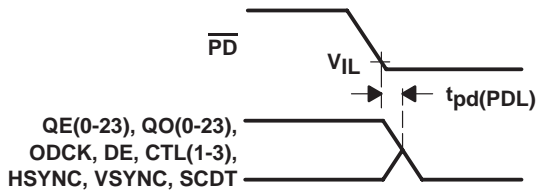

Figure 7. Delay From \overline{PD} Low to Hi-Z Outputs

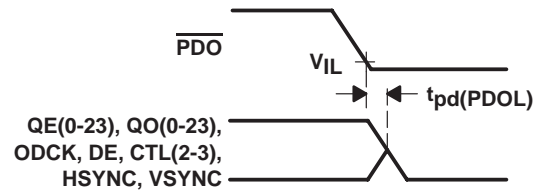

Figure 8. Delay From \overline{PDO} Low to Hi-Z Outputs

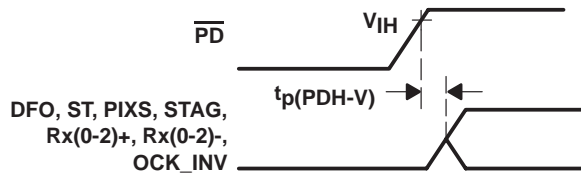

Figure 9. Delay From \overline{PD} Low to High Before Inputs are Active

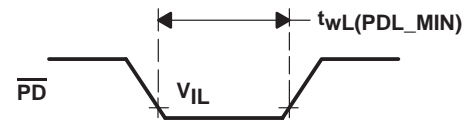

Figure 10. Minimum Time \overline{PD} Low

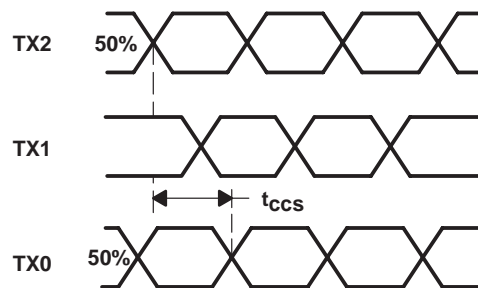

Figure 11. Analog Input Channel-to-Channel Skew

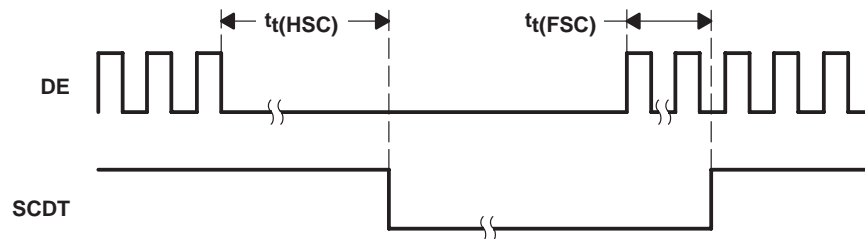

Figure 12. Time Between DE Transitions to SCDT Low and SCDT High

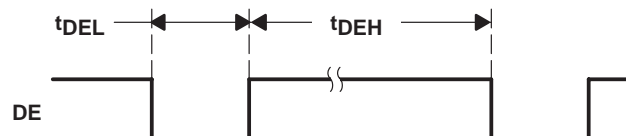

Figure 13. Minimum DE Low and Maximum DE High

TFP101, TFP101A

TI PanelBus™ DIGITAL RECEIVER

SLDS119C - MARCH 2000 – REVISED OCTOBER 2003

detailed description

fundamental operation

The TFP101/101A is a digital visual interface (DVI) compliant TMDS digital receiver that is used in digital flat panel display systems to receive and decode TMDS encoded RGB pixel data streams. In a digital display system a host, usually a PC or workstation, contains a TMDS compatible transmitter that receives 24 bit pixel data along with appropriate control signals and encodes them into a high-speed low-voltage differential serial bit stream fit for transmission over a twisted-pair cable to a display device. The display device, usually a flat-panel monitor, will require a TMDS compatible receiver like the TI TFP101/101A to decode the serial bit stream back to the same 24 bit pixel data and control signals that originated at the host. This decoded data can then be applied directly to the flat panel drive circuitry to produce an image on the display. Since the host and display can be separated by distances up to 5 meters or more, serial transmission of the pixel data is preferred. To support modern display resolutions up to SXGA a high bandwidth receiver with good jitter and skew tolerance is required.

TMDS pixel data and control signal encoding

TMDS stands for transition minimized differential signaling. Only one of two possible TMDS characters for a given pixel will be transmitted at a given time. The transmitter keeps a running count of the number of ones and zeros previously sent and transmits the character that will minimize the number of transitions and approximate a dc balance of the transmission line.

Three TMDS channels are used to receive RGB pixel data during active display time, DE = high. The same three channels also receive control signals, HSYNC, VSYNC, and user defined control signals CTL[3:1]. These control signals are received during inactive display or blanking-time. Blanking-time is when DE = low. The following table maps the received input data to appropriate TMDS input channel in a DVI compliant system.

RECEIVED PIXEL DATA ACTIVE DISPLAY DE = HIGH	INPUT CHANNEL	OUTPUT PINS (VALID FOR DE = HIGH)
Red[7:0]	Channel – 2 (Rx2 ±)	QE[23:16] QO[23:16]
Green[7:0]	Channel – 1 (Rx1 ±)	QE[15:8] QO[15:8]
Blue[7:0]	Channel – 0 (Rx0 ±)	QE[7:0] QO[7:0]
RECEIVED CONTROL DATA BLANKING DE = LOW	INPUT CHANNEL	OUTPUT PINS (VALID FOR DE = LOW)
CTL[3:2]	Channel – 2 (Rx2 ±)	CTL[3:2]
CTL[1: 0] (see Note 6)	Channel – 1 (Rx1 ±)	CTL1
HSYNC, VSYNC	Channel – 0 (Rx0 ±)	HSYNC, VSYNC

NOTE 7: Some TMDS transmitters transmit a CTL0 signal. The TFP101/101A decodes and transfers CTL[3:1] and ignores CTL0 characters. CTL0 is not available as a TFP101/101A output.

The TFP101/101A discriminates between valid pixel TMDS characters and control TMDS characters to determine the state of active display versus blanking, i.e., state of DE.



POST OFFICE BOX 655303 • DALLAS, TEXAS 75265

detailed description (continued)**TFP101/101A clocking and data synchronization**

The TFP101/101A receives a clock reference from the DVI transmitter that has a period equal to the pixel time, T_{pix} . The frequency of this clock is also referred to as the pixel rate. Since the TMDS encoded data on $Rx[2:0]$ contains 10 bits per 8 bit pixel it follows that the $Rx[2:0]$ serial bit rate is 10 times the pixel rate. For example, the required pixel rate to support an XGA resolution with 60 Hz refresh rate is 65 MHz. The TMDS serial bit rate is 10x the pixel rate or 650 Mb/s. Due to the transmission of this high-speed digital bit stream, on three separate channels (or twisted-pair wires) of long distances (3-5 meters), phase synchronization between the data streams and the input reference clock is not guaranteed. In addition, skew between the three data channels is common. The TFP101/101A uses a 4x oversampling scheme of the input data streams to achieve reliable synchronization with up to 1- T_{pix} channel-to-channel skew tolerance. Accumulated jitter on the clock and data lines due to reflections and external noise sources is also typical of high speed serial data transmission, hence the TFP101/101A's design for high jitter tolerance.

The input clock to the TFP101/101A is conditioned by a phase-locked-loop (PLL) to remove high frequency jitter from the clock. The PLL provides four 10x clock outputs of different phase to locate and sync the TMDS data streams (4x oversampling). During active display the pixel data is encoded to be transition minimized, whereas in blank, the control data is encoded to be transition maximized. A DVI compliant transmitter is required to transmit in blank for a minimum period of time, 128- T_{pix} , to ensure sufficient time for data synchronization when the receiver sees a transition maximized code. Synchronization during blank, when the data is transition maximized, ensures reliable data bit boundary detection. Phase synchronization to the data streams is unique for each of the three input channels and is maintained as long as the link remains active.

TFP101/101A TMDS input levels and input impedance matching

The TMDS inputs to the TFP101/101A receiver have a fixed single-ended termination to AV_{DD} . The TFP101/101A is internally optimized using a laser trim process to precisely fix the impedance at 50 Ω . The device will function normally with or without a resistor on the EXT_RES pin, so it remains drop-in compatible with current sockets. The fixed impedance eliminates the need for an external resistor while providing optimum impedance matching to standard 50- Ω DVI cables.

Figure 14 shows a conceptual schematic of a DVI transmitter and TFP101/101A receiver connection. A transmitter drives the twisted pair cable via a current source, usually achieved with an open drain type output driver. The internal resistor, which is matched to the cable impedance, at the TFP101/101A input provides a pullup to AV_{DD} . Naturally, when the transmitter is disconnected and the TFP101/101A DVI inputs are left unconnected, the TFP101/101A receiver inputs pullup to AV_{DD} . The single ended differential signal and full differential signal is shown in Figure 15. The TFP101/101A is designed to respond to differential signal swings ranging from 150 mV to 1.56 V with common mode voltages ranging from (AV_{DD} -300 mV) to (AV_{DD} -37 mV).

TFP101/101A TMDS input levels and input impedance matching (continued)

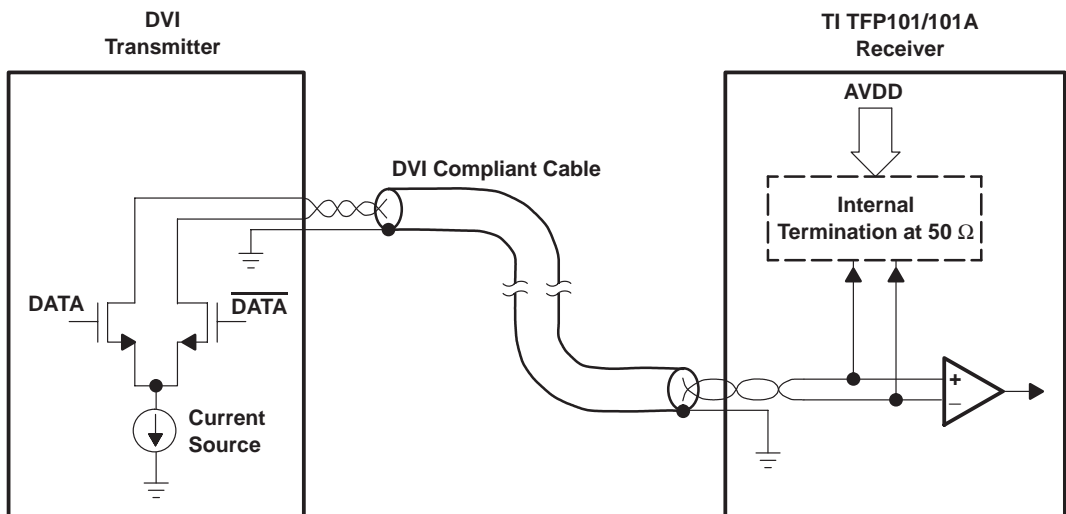

Figure 14. TMDS Differential Input and Transmitter Connection

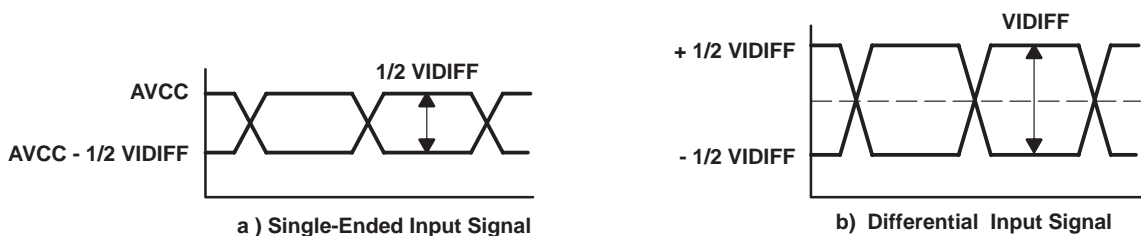

Figure 15. TMDS Inputs

TFP101A incorporates HSYNC jitter immunity

Several DVI transmitters available in the market introduce jitter on the transmitted HSYNC and VSYNC signals during the TMDS encryption process. The HSYNC signal can shift by one pixel position (one clock) from nominal in either direction, resulting in up to two cycles of HSYNC shift. This jitter carries through to the DVI receiver, and if the position of HSYNC shifts continuously, the receiver can lose track of the input timing and pixel noise will occur on the display. For this reason, a DVI compliant receiver with HSYNC jitter immunity should be used in all displays that could be connected to host PCs with transmitters that have this HSYNC jitter problem.

The TFP101A integrates HSYNC regeneration circuitry that provides a seamless interface to these noncompliant transmitters. The position of the data enable (DE) signal is always fixed in relation to data, irrespective of the location of HSYNC. The TFP101A receiver uses the DE and clock signals recreate stable vertical and horizontal sync signals. The circuit filters the HSYNC output of the receiver, and HSYNC is shifted to the nearest eighth bit boundary, producing a stable output with respect to data, as shown in Figure 16. This will ensure accurate data synchronization at the input of the display timing controller.

This HSYNC regeneration circuit is transparent to the monitor and need not be removed even if the transmitted HSYNC is stable. For example, the PanelBus line of DVI 1.0 compliant transmitters, such as the TFP6422 and TFP420, do not have the HSYNC jitter problem. The TFP101A will operate correctly with either compliant or noncompliant transmitters. In contrast, the TFP101 is ideal for customers who have control over the transmit portion of the design such as bundled system manufacturers and for internal monitor use (the DVI connection between monitor and panel modules).

TFP101A incorporates HSYNC jitter immunity (continued)

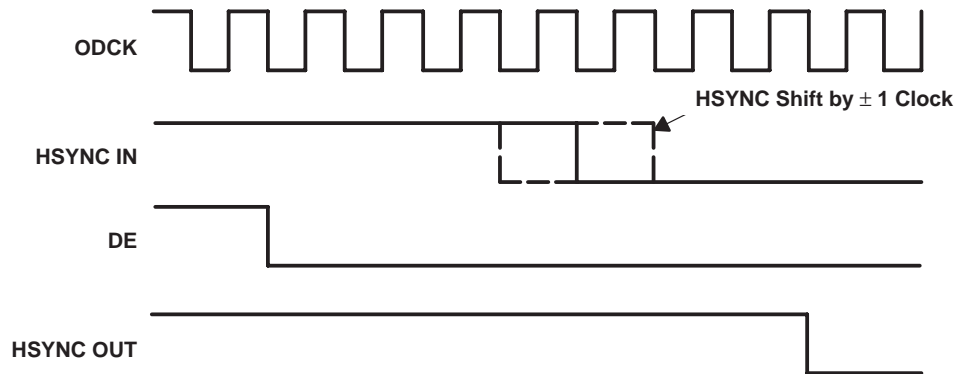

Figure 16. HSYNC Regeneration Timing Diagram

TFP101/101A modes of operation

The TFP101/101A provides systems design flexibility and value by providing the system designer with configurable options or modes of operation to support varying system architectures. The following table outlines the various panel modes that can be supported along with appropriate external control pin settings.

PANEL	PIXEL RATE	ODCK LATCH EDGE	ODCK	DFO	PIXS	OCK_INV
TFT or 16-bit DSTN	1 pix/clock	Falling	Free run	0	0	0
TFT or 16-bit DSTN	1 pix/clock	Rising	Free run	0	0	1
TFT	2 pix/clock	Falling	Free run	0	1	0
TFT	2 pix/clock	Rising	Free run	0	1	1
24-bit DSTN	1 pix/clock	Falling	Gated low	1	0	0
NONE	1 pix/clock	Rising	Gated low	1	0	1
24-bit DSTN	2 pix/clock	Falling	Gated low	1	1	0
24-bit DSTN	2 pix/clock	Rising	Gated low	1	1	1

TFP101/101A output driver configurations

The TFP101/101A provides flexibility by offering various output driver features that can be used to optimize power consumption, ground-bounce and power-supply noise. The following sections outline the output driver features and their effects.

Output driver power down (\overline{PDO} = low), Pulling \overline{PDO} low will place all the output drivers, except CTL1 and SCDT, into a high-impedance state. The SCDT output which indicates link-disabled or link-inactive can be tied directly to the \overline{PDO} input to disable the output drivers when the link is inactive or when the cable is disconnected. An internal pullup on the \overline{PDO} pin will default the TFP101/101A to the normal nonpower down output drive mode if left unconnected.

Drive Strength (ST = high for high drive strength, ST=low for low drive strength.) The TFP101/101A allows for selectable output drive strength on the data, control and ODCK outputs. See the dc specifications table for the values of I_{OH} and I_{OL} current drives for a given ST state. The high output strength offers approximately two times the drive as the low output drive strength.

TFP101, TFP101A

TI PanelBus™ DIGITAL RECEIVER

SLDS119C - MARCH 2000 – REVISED OCTOBER 2003

TFP101/101A output driver configurations (continued)

Time Staggered Pixel Output. This option works only in conjunction with the 2-pixel/clock mode (PIXS = high). Setting $\overline{\text{STAG}}$ = low will time stagger the even and odd pixel output so as to reduce the amount of instantaneous current surge from the power supply. Depending on the PCB layout and design this can help reduce the amount of system ground bounce and power supply noise. The time stagger is such that in 2-pixel/clock mode the even pixel is delayed from the latching edge of ODCK by $0.25 T_{\text{cip}}$. (T_{cip} is the period of ODCK. The ODCK period is $2T_{\text{pix}}$ when in 2-pixel/clock mode.)

Depending on system constraints of output load, pixel rate, panel input architecture and board cost the TFP101/101A drive strength and staggered pixel options allow flexibility to reduce system power-supply noise, ground bounce and EMI.

Power Management. The TFP101/101A offers several system power management features.

The output driver power down ($\overline{\text{PDO}}$ = low) is an intermediate mode which offers several uses. During this mode, all output drivers except SCDT and CTL1 are driven to a high impedance state while the rest of the device circuitry remains active

The TFP101/101A power down ($\overline{\text{PD}}$ = low) is a complete power down in that it powers down the digital core, the analog circuitry, and output drivers. All output drivers are placed into a Hi-z state. All inputs are disabled except for the $\overline{\text{PD}}$ input. The TFP101/101A will not respond to any digital or analog inputs until $\overline{\text{PD}}$ is pulled high.

Both $\overline{\text{PDO}}$ and $\overline{\text{PD}}$ have internal pullups so if left unconnected they will default the TFP101/101A to normal operating modes.

Sync Detect. The TFP101/101A offers an output, SCDT to indicate link activity. The TFP101/101A monitors activity on DE to determine if the link is active. When 1 million (1e6) pixel clock periods pass without a transition on DE, the TFP101/101A considers the link inactive and SCDT is driven low. While SCDT is low, if two DE transitions are detected within 1024 pixel clock periods, the link will be considered active and SCDT is pulled high.

SCDT can be used to signal a system power management circuit to initiate a system power down when the link is considered inactive. The SCDT can also be tied directly to the TFP101/101A $\overline{\text{PDO}}$ input to power down the output drivers when the link is inactive. It is not recommended to use the SCDT to drive the $\overline{\text{PD}}$ input since, once in complete power-down, the analog inputs are ignored and the SCDT state will not change. An external system power management circuit to drive $\overline{\text{PD}}$ is preferred.



POST OFFICE BOX 655303 • DALLAS, TEXAS 75265

TI PowerPAD™ 100-TQFP package

The TFP101/101A is packaged in TI's thermally enhanced PowerPAD™ 100TQFP packaging. The PowerPAD™ package is a 14 mm × 14 mm × 1 mm TQFP outline with 0.5mm lead-pitch. The PowerPAD™ package has a specially designed die mount pad that offers improved thermal capability over typical TQFP packages of the same outline. The TI 100-TQFP PowerPAD™ package offers a back-side solder plane that connects directly to the die mount pad for enhanced thermal conduction. Soldering the back side of the TFP101/101A to the application board is not required thermally as the device power dissipation is well within the package capability when not soldered.

Soldering the back side of the device to the PCB ground plane is recommended for electrical considerations. Since the die pad is electrically connected to the chip substrate and hence chip ground, connection of the PowerPAD back side to a PCB ground plane will help to improve EMI, ground bounce, and power supply noise performance.

Table 1 outlines the thermal properties of the TI 100-TQFP PowerPAD™ package. The 100-TQFP non-PowerPAD™ package is included only for reference.

Table 1. TI 100-TQFP (14 × 14 × 1 mm)/0.5 mm Lead Pitch

PARAMETER	WITHOUT PowerPAD™	PowerPAD™ NOT CONNECTED TO PCB THERMAL PLANE	PowerPAD™ CONNECTED TO PCB THERMAL PLANE†
Theta-JA†,‡	45°C/W	27.3°C/W	17.3°C/W
Theta-JC†,‡	3.11°C/W	0.12°C/W	0.12°C/W
Maximum power dissipation†,‡,§	1.6 W	2.7 W	4.3 W

† Specified with 2 oz. Cu PCB plating.

‡ Airflow is at 0 LFM (no airflow)

§ Measured at ambient temperature, T_A = 70°C.

PACKAGING INFORMATION

Orderable Device	Status (1)	Package Type	Package Drawing	Pins	Package Qty	Eco Plan (2)	Lead finish/ Ball material (6)	MSL Peak Temp (3)	Op Temp (°C)	Device Marking (4/5)	Samples
TFP101APZP	NRND	HTQFP	PZP	100	90	RoHS & Green	NIPDAU	Level-3-260C-168 HR	0 to 70	TFP101APZP	

(1) The marketing status values are defined as follows:

ACTIVE: Product device recommended for new designs.

LIFEBUY: TI has announced that the device will be discontinued, and a lifetime-buy period is in effect.

NRND: Not recommended for new designs. Device is in production to support existing customers, but TI does not recommend using this part in a new design.

PREVIEW: Device has been announced but is not in production. Samples may or may not be available.

OBSOLETE: TI has discontinued the production of the device.

(2) **RoHS:** TI defines "RoHS" to mean semiconductor products that are compliant with the current EU RoHS requirements for all 10 RoHS substances, including the requirement that RoHS substance do not exceed 0.1% by weight in homogeneous materials. Where designed to be soldered at high temperatures, "RoHS" products are suitable for use in specified lead-free processes. TI may reference these types of products as "Pb-Free".

RoHS Exempt: TI defines "RoHS Exempt" to mean products that contain lead but are compliant with EU RoHS pursuant to a specific EU RoHS exemption.

Green: TI defines "Green" to mean the content of Chlorine (Cl) and Bromine (Br) based flame retardants meet JS709B low halogen requirements of <=1000ppm threshold. Antimony trioxide based flame retardants must also meet the <=1000ppm threshold requirement.

(3) MSL, Peak Temp. - The Moisture Sensitivity Level rating according to the JEDEC industry standard classifications, and peak solder temperature.

(4) There may be additional marking, which relates to the logo, the lot trace code information, or the environmental category on the device.

(5) Multiple Device Markings will be inside parentheses. Only one Device Marking contained in parentheses and separated by a "-" will appear on a device. If a line is indented then it is a continuation of the previous line and the two combined represent the entire Device Marking for that device.

(6) Lead finish/Ball material - Orderable Devices may have multiple material finish options. Finish options are separated by a vertical ruled line. Lead finish/Ball material values may wrap to two lines if the finish value exceeds the maximum column width.

Important Information and Disclaimer:The information provided on this page represents TI's knowledge and belief as of the date that it is provided. TI bases its knowledge and belief on information provided by third parties, and makes no representation or warranty as to the accuracy of such information. Efforts are underway to better integrate information from third parties. TI has taken and continues to take reasonable steps to provide representative and accurate information but may not have conducted destructive testing or chemical analysis on incoming materials and chemicals. TI and TI suppliers consider certain information to be proprietary, and thus CAS numbers and other limited information may not be available for release.

In no event shall TI's liability arising out of such information exceed the total purchase price of the TI part(s) at issue in this document sold by TI to Customer on an annual basis.

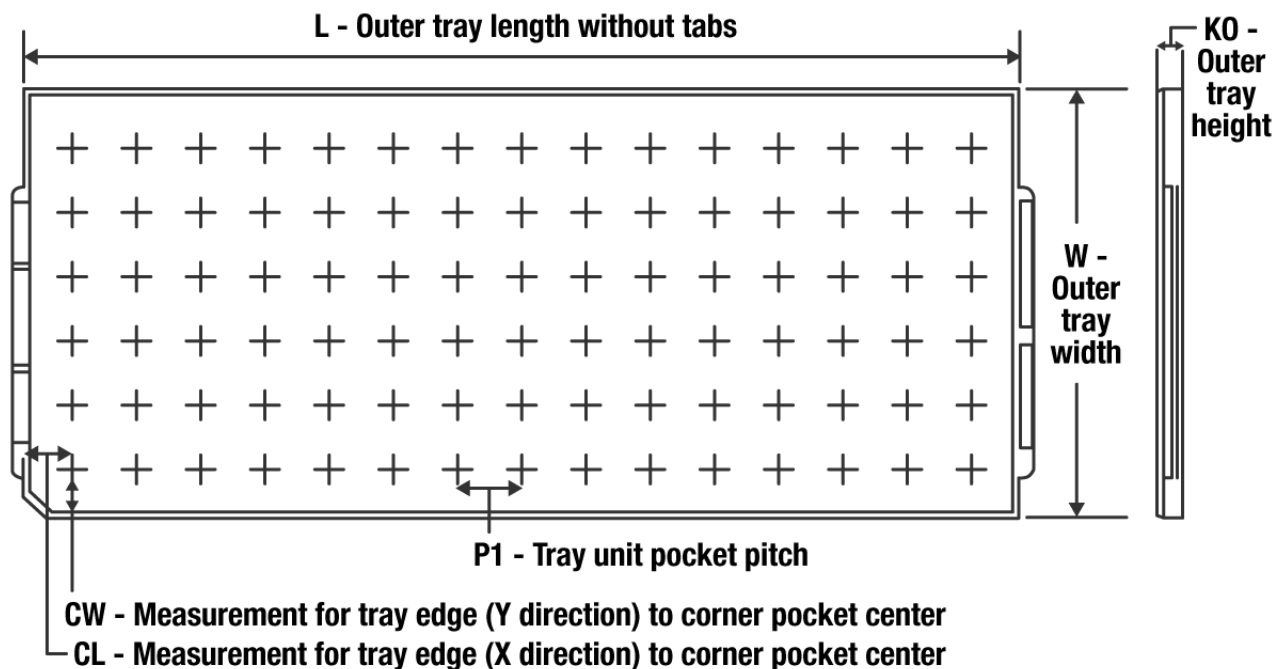
TRAY

Chamfer on Tray corner indicates Pin 1 orientation of packed units.

*All dimensions are nominal

Device	Package Name	Package Type	Pins	SPQ	Unit array matrix	Max temperature (°C)	L (mm)	W (mm)	K0 (µm)	P1 (mm)	CL (mm)	CW (mm)
TFP101APZP	PZP	HTQFP	100	90	6 X 15	150	315	135.9	7620	20.3	15.4	15.45

GENERIC PACKAGE VIEW

PZP 100

PowerPAD™ TQFP - 1.2 mm max height

14 x 14 mm Pkg Body, 0.5 mm pitch
16 x 16 mm Pkg Area

PLASTIC QUAD FLATPACK

This image is a representation of the package family, actual package may vary.
Refer to the product data sheet for package details.

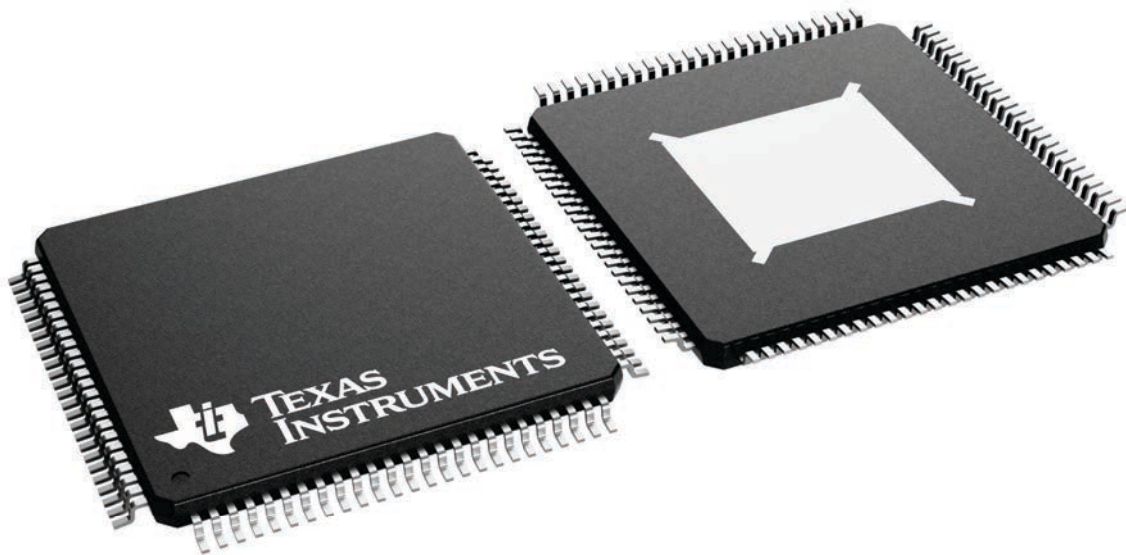

4224739/B

MECHANICAL DATA

PZP (S-PQFP-G100)

PowerPAD™ PLASTIC QUAD FLATPACK

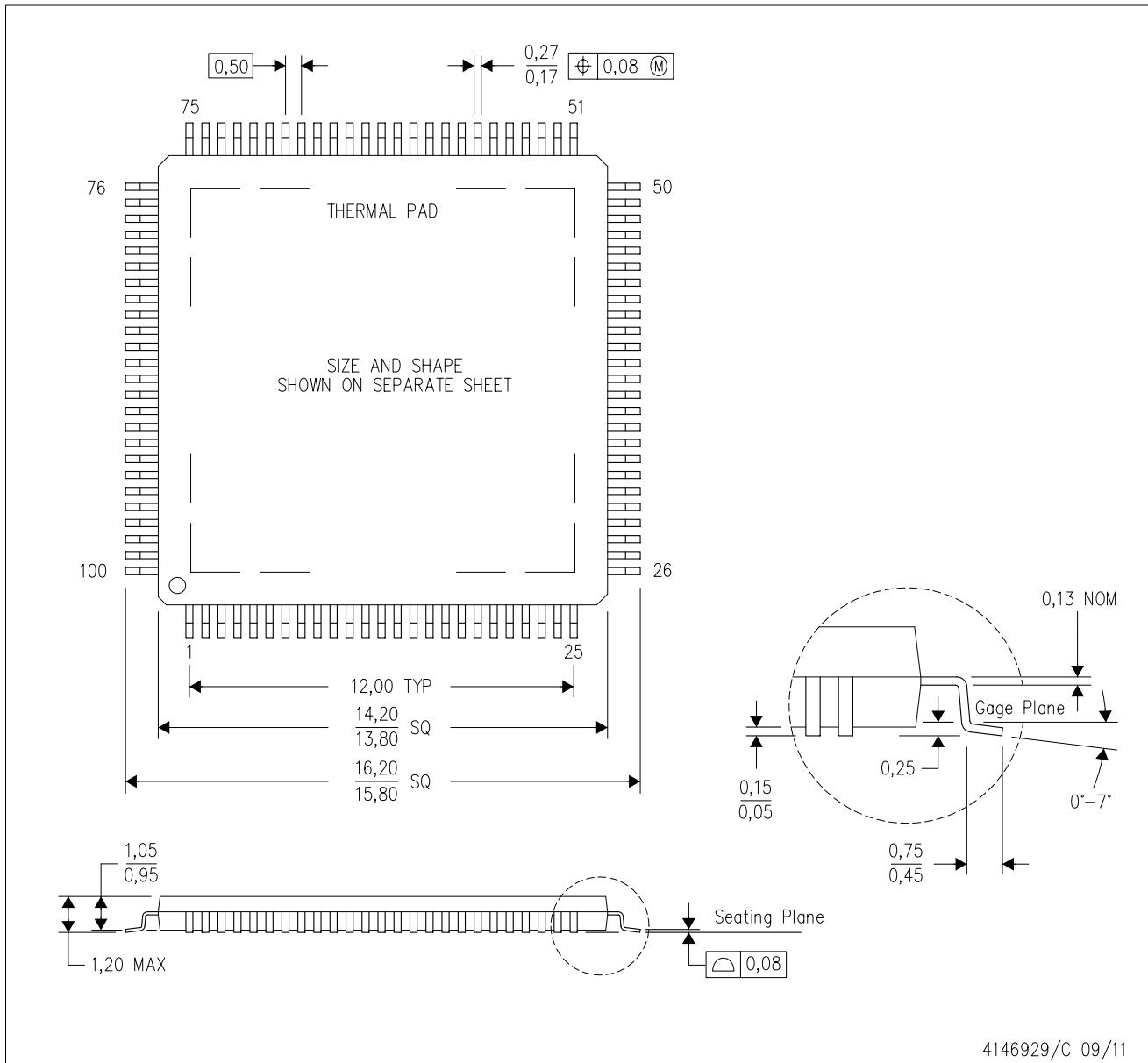

- NOTES:
- A. All linear dimensions are in millimeters.
 - B. This drawing is subject to change without notice.
 - C. Body dimensions do not include mold flash or protrusion
 - D. This package is designed to be soldered to a thermal pad on the board. Refer to Technical Brief, PowerPad Thermally Enhanced Package, Texas Instruments Literature No. SLMA002 for information regarding recommended board layout. This document is available at www.ti.com <<http://www.ti.com>>.
 - E. See the additional figure in the Product Data Sheet for details regarding the exposed thermal pad features and dimensions.
 - F. Falls within JEDEC MS-026

PowerPAD is a trademark of Texas Instruments.

THERMAL PAD MECHANICAL DATA

PZP (S-PQFP-G100)

PowerPAD™ PLASTIC QUAD FLATPACK

THERMAL INFORMATION

This PowerPAD™ package incorporates an exposed thermal pad that is designed to be attached to a printed circuit board (PCB). The thermal pad must be soldered directly to the PCB. After soldering, the PCB can be used as a heatsink. In addition, through the use of thermal vias, the thermal pad can be attached directly to the appropriate copper plane shown in the electrical schematic for the device, or alternatively, can be attached to a special heatsink structure designed into the PCB. This design optimizes the heat transfer from the integrated circuit (IC).

For additional information on the PowerPAD package and how to take advantage of its heat dissipating abilities, refer to Technical Brief, PowerPAD Thermally Enhanced Package, Texas Instruments Literature No. SLMA002 and Application Brief, PowerPAD Made Easy, Texas Instruments Literature No. SLMA004. Both documents are available at www.ti.com.

The exposed thermal pad dimensions for this package are shown in the following illustration.

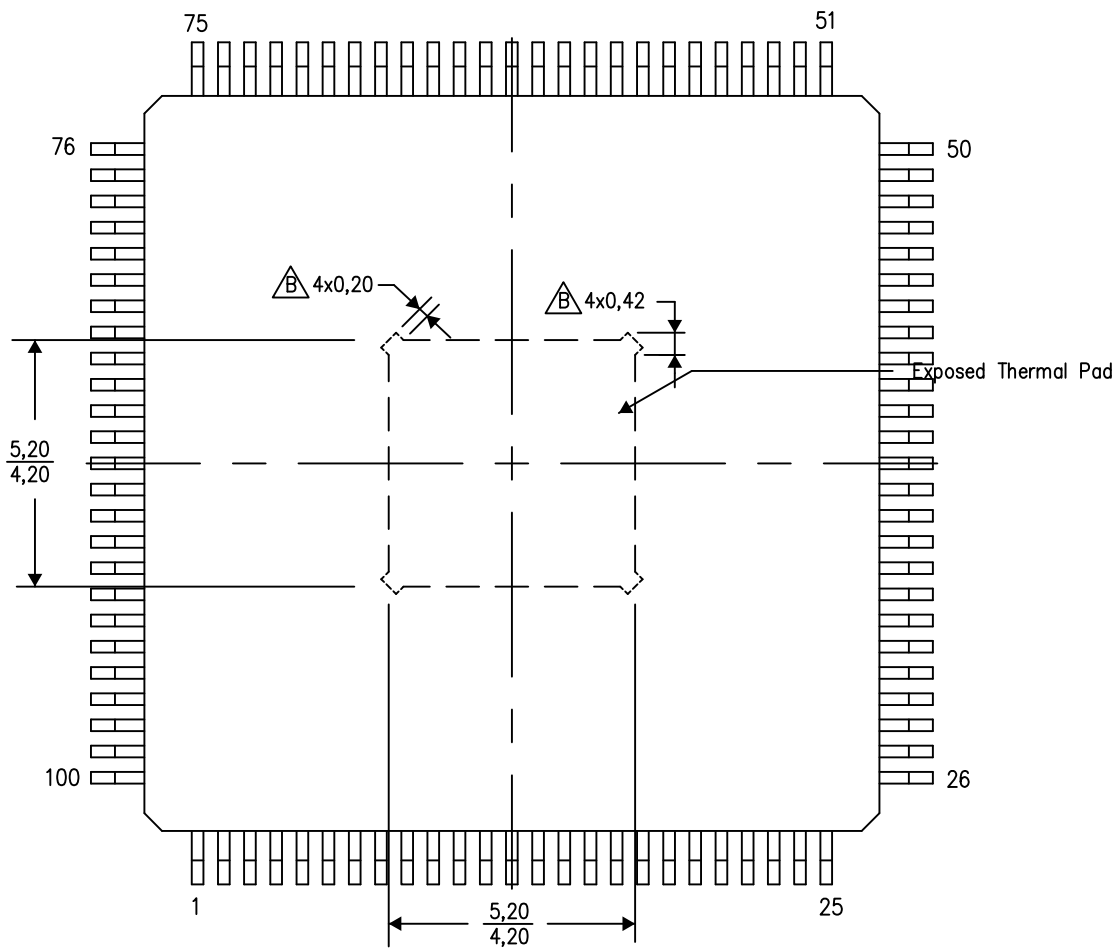

4206333-2/L 05/14

NOTE: A. All linear dimensions are in millimeters

 Tie strap features may not be present.

PowerPAD is a trademark of Texas Instruments

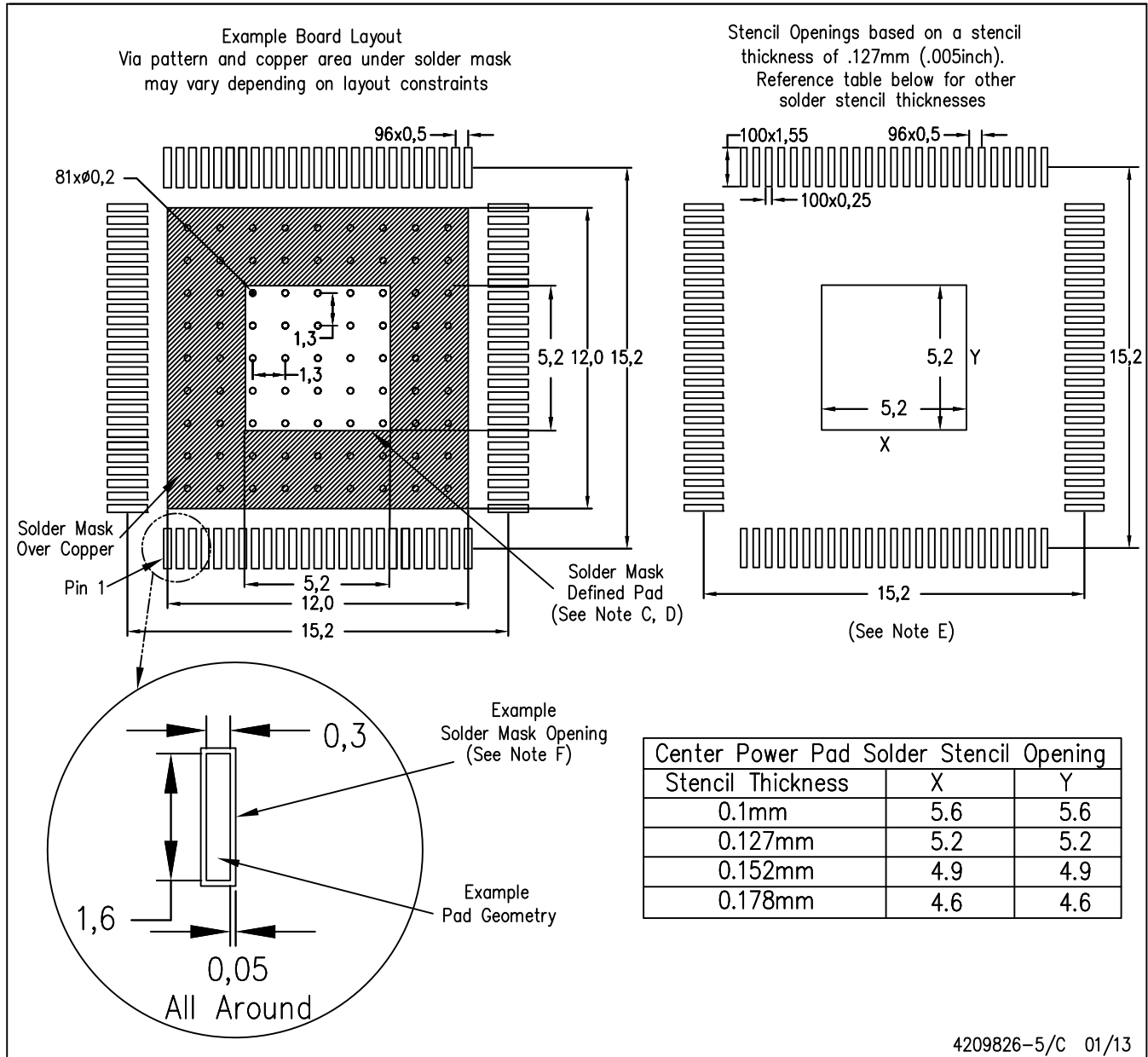

- NOTES:
- A. All linear dimensions are in millimeters.
 - B. This drawing is subject to change without notice.
 - C. Customers should place a note on the circuit board fabrication drawing not to alter the center solder mask defined pad.
 - D. This package is designed to be soldered to a thermal pad on the board. Refer to Technical Brief, PowerPAD Thermally Enhanced Package, Texas Instruments Literature No. SLMA002, SLMA004, and also the Product Data Sheets for specific thermal information, via requirements, and recommended board layout. These documents are available at www.ti.com <<http://www.ti.com>>. Publication IPC-7351 is recommended for alternate designs.
 - E. Laser cutting apertures with trapezoidal walls and also rounding corners will offer better paste release. Customers should contact their board assembly site for stencil design recommendations. Example stencil design based on a 50% volumetric metal load solder paste. Refer to IPC-7525 for other stencil recommendations.
 - F. Customers should contact their board fabrication site for solder mask tolerances between and around signal pads.

PowerPAD is a trademark of Texas Instruments.

IMPORTANT NOTICE AND DISCLAIMER

TI PROVIDES TECHNICAL AND RELIABILITY DATA (INCLUDING DATA SHEETS), DESIGN RESOURCES (INCLUDING REFERENCE DESIGNS), APPLICATION OR OTHER DESIGN ADVICE, WEB TOOLS, SAFETY INFORMATION, AND OTHER RESOURCES "AS IS" AND WITH ALL FAULTS, AND DISCLAIMS ALL WARRANTIES, EXPRESS AND IMPLIED, INCLUDING WITHOUT LIMITATION ANY IMPLIED WARRANTIES OF MERCHANTABILITY, FITNESS FOR A PARTICULAR PURPOSE OR NON-INFRINGEMENT OF THIRD PARTY INTELLECTUAL PROPERTY RIGHTS.

These resources are intended for skilled developers designing with TI products. You are solely responsible for (1) selecting the appropriate TI products for your application, (2) designing, validating and testing your application, and (3) ensuring your application meets applicable standards, and any other safety, security, regulatory or other requirements.

These resources are subject to change without notice. TI grants you permission to use these resources only for development of an application that uses the TI products described in the resource. Other reproduction and display of these resources is prohibited. No license is granted to any other TI intellectual property right or to any third party intellectual property right. TI disclaims responsibility for, and you will fully indemnify TI and its representatives against, any claims, damages, costs, losses, and liabilities arising out of your use of these resources.

TI's products are provided subject to [TI's Terms of Sale](#) or other applicable terms available either on [ti.com](https://www.ti.com) or provided in conjunction with such TI products. TI's provision of these resources does not expand or otherwise alter TI's applicable warranties or warranty disclaimers for TI products.

TI objects to and rejects any additional or different terms you may have proposed.

Mailing Address: Texas Instruments, Post Office Box 655303, Dallas, Texas 75265
Copyright © 2023, Texas Instruments Incorporated

Looking for pricing, stock, or lifecycle information?

Click below to explore more details on WIN SOURCE:

 [View TFP101PZP on WIN SOURCE](#)

 [Texas Instruments](#) Information

Optimize Your Supply Chain with WIN SOURCE Solutions

-  Global Sourcing Solution
-  Obsolete Management
-  Cost Control Management
-  Shortage Management
-  Alternative Solution
-  Excess Inventory Management