



**THE DATASHEET OF**  
**85354AK-01LFT**





**GENERAL DESCRIPTION**

The ICS85354-01 is a 2:1/1:2 Multiplexer and a member of the HiPerClockS™ family of high performance clock solutions from IDT. The 2:1 Multiplexer allows one of 2 inputs to be selected onto one output pin and the 1:2 MUX switches one input to one of two outputs. This device may be useful for multiplexing multi-rate Ethernet Phys which have 100Mbit and 1000Mbit transmit/receive pairs onto an optical SFP module which has a single transmit/receive pair. A 3<sup>rd</sup> mode allows loop back testing and allows the output of a phy transmit pair to be routed to the phy input pair. For examples, please refer to the Application Block diagrams on pages 2-3 of the data sheet.

The ICS85354-01 is optimized for applications requiring very high performance and has a maximum operating frequency in 2.5GHz. The device is packaged in a small, 3mm x 3mm VFQFN package, making it ideal for use on space-constrained boards.

**FEATURES**

- Dual 2:1/1:2 MUX
- Three differential LVPECL outputs
- Three differential LVPECL clock inputs
- CLKx pair can accept the following differential input levels: LVPECL, LVDS, CML
- Loopback test mode available
- Maximum output frequency: 2.5GHz
- Part-to-part skew: 85ps (typical)
- Additive jitter, RMS: 0.05ps (typical)
- Propagation delay: 440ps (typical)
- LVPECL mode operating voltage supply range:  $V_{CC} = 2.375V$  to  $3.465V$ ,  $V_{EE} = 0V$
- ECL mode operating voltage supply range:  $V_{CC} = 0V$ ,  $V_{EE} = -3.465V$  to  $-2.375V$
- -40°C to 85°C ambient operating temperature
- Available in both standard (RoHS5) and lead-free (RoHS 6) packages

**BLOCK DIAGRAM**

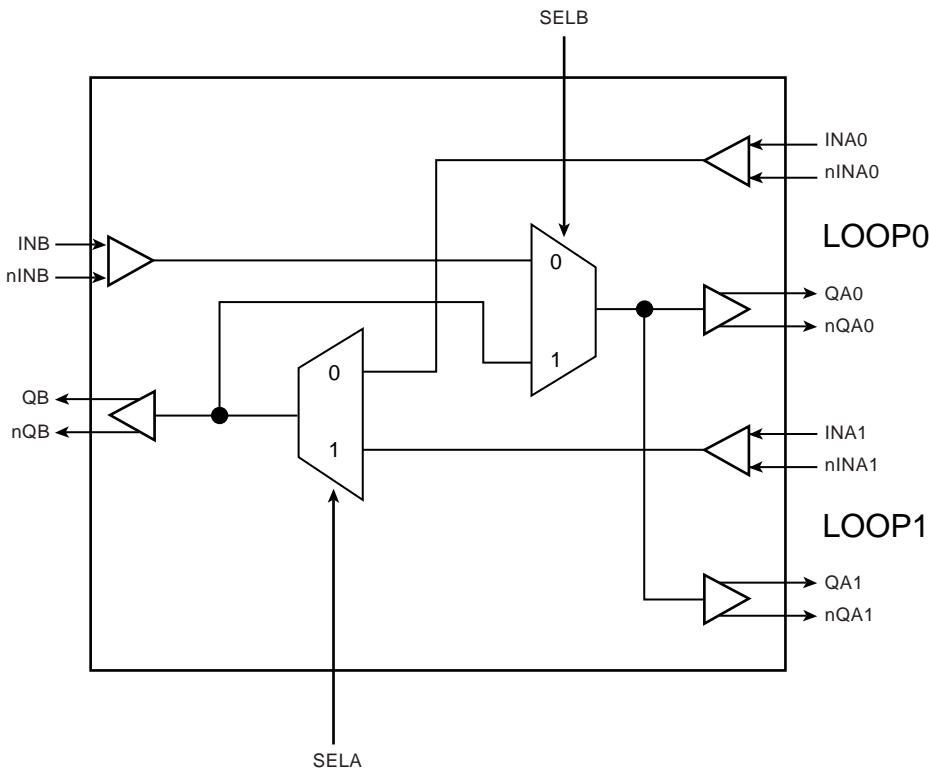

**PIN ASSIGNMENT**

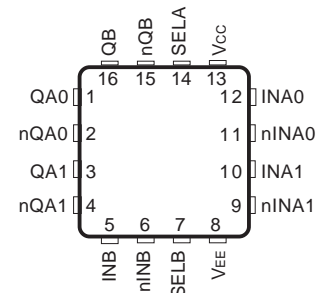

**ICS85354-01**

**16-Lead VFQFN**

3mm x 3mm x 0.925 package body

**K Package**

Top View

The Preliminary Information presented herein represents a product in pre-production. The noted characteristics are based on initial product characterization and/or qualification. Integrated Device Technology, Incorporated (IDT) reserves the right to change any circuitry or specifications without notice.



HOST BUS ADAPTER BOARDS FOR ROUTING BETWEEN INTERNAL AND EXTERNAL CONNECTORS

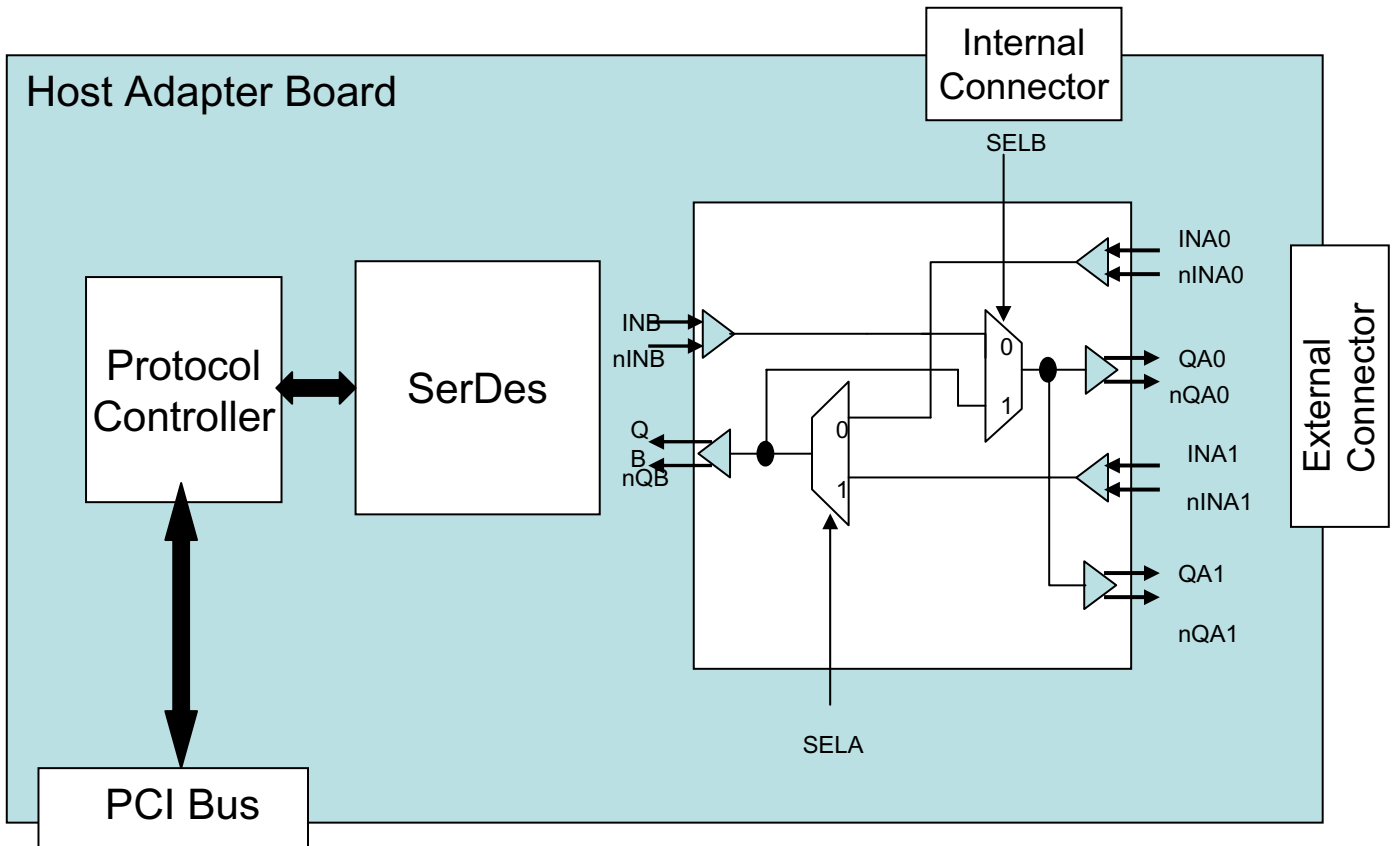



HOT-SWAPPABLE LINKS TO REDUNDANT SWITCH FABRIC CARDS

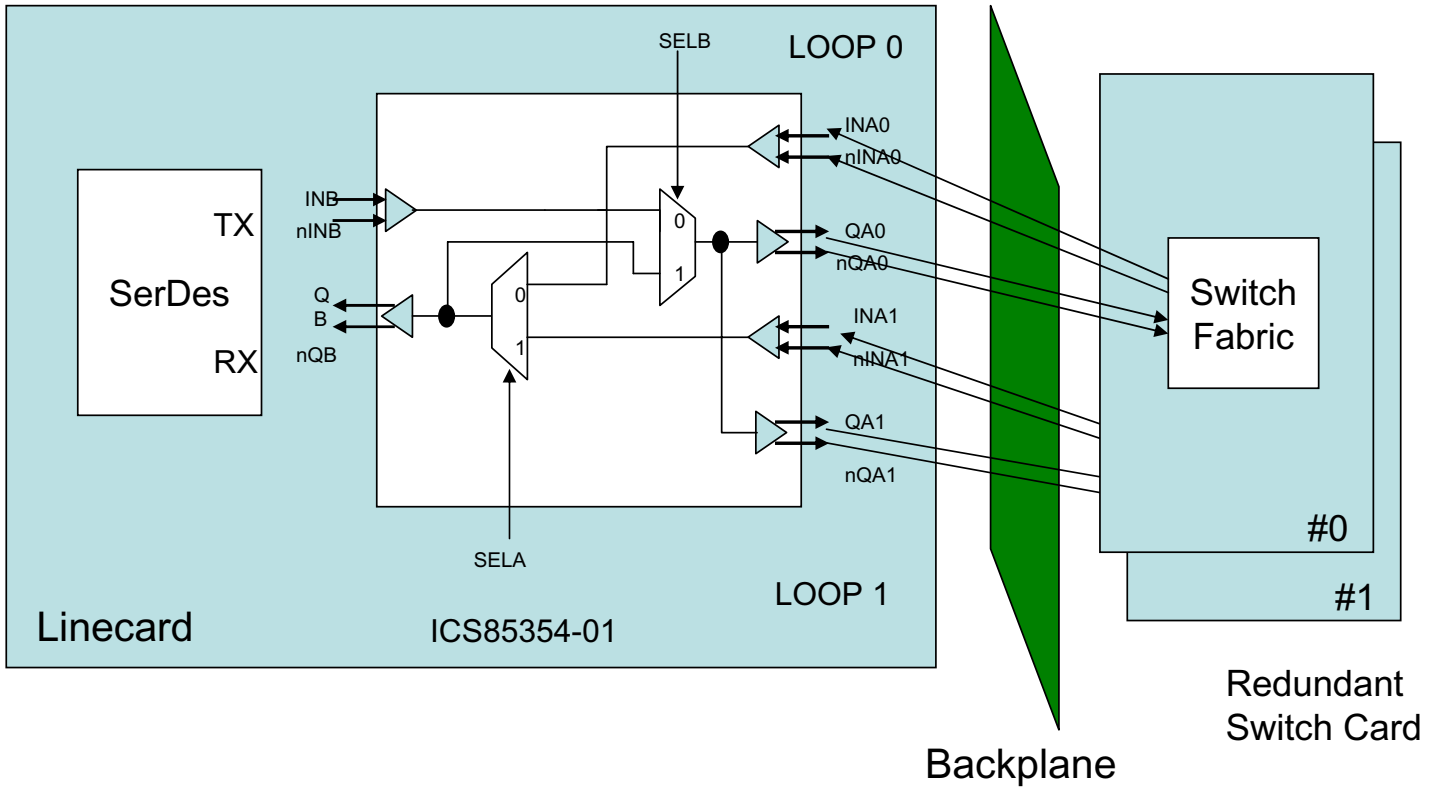



**TABLE 1. PIN DESCRIPTIONS**

Number	Name	Type		Description
1, 2	QA0, nQA0	Output		Differential output pair. LVPECL/ECL interface levels.
3, 4	QA1, nQA1	Output		Differential output pair. LVPECL/ECL interface levels.
5	INB	Input	Pulldown	Non-inverting LVPECL/ECL differential clock input.
6	nINB	Input	Pullup/ Pulldown	Inverting differential LVPECL clock input. $V_{CC}/2$ default when left floating.
7	SELB	Input	Pulldown	Clock select pin for QBx outputs. When HIGH, selects QB1, nQB1 outputs. When LOW, selects QB0, nQB0 outputs. LVCMOS/LVTTL interface levels.
8	$V_{EE}$	Power		Negative supply pin.
9	nINA1	Input	Pullup/ Pulldown	Inverting differential LVPECL clock input. $V_{CC}/2$ default when left floating.
10	INA1	Input	Pulldown	Non-inverting LVPECL differential clock input.
11	nINA0	Input	Pullup/ Pulldown	Inverting differential LVPECL clock input. $V_{CC}/2$ default when left floating.
12	INA0	Input	Pulldown	Non-inverting LVPECL differential clock input.
13	$V_{CC}$	Power		Positive supply pin.
14	SELA	Input	Pulldown	Clock select pin for QA outputs. When HIGH, selects QA output. When LOW, selects nQA output. LVCMOS/LVTTL interface levels.
15, 16	nQB, QB	Output		Differential output pair. LVPECL/ECL interface levels.

NOTE: *Pulldown* and *Pullup* refer to internal input resistors. See Table 2, Pin Characteristics, for typical values.

**TABLE 2. PIN CHARACTERISTICS**

Symbol	Parameter	Test Conditions	Minimum	Typical	Maximum	Units
$R_{PULLDOWN}$	Input Pulldown Resistor			37.5		k $\Omega$
$R_{VCC/2}$	Pullup/Pulldown Resistors			37.5		k $\Omega$

**TABLE 3. INPUT CONTROL FUNCTION TABLE**

Control Inputs		Mode
SELA	SELB	
0	0	LOOP0 selected
0	1	LOOP1 selected
1	0	Loopback mode: LOOP0
1	1	Loopback mode: LOOP1



#### ABSOLUTE MAXIMUM RATINGS

Supply Voltage, $V_{CC}$	4.6V (LVPECL mode, $V_{EE} = 0$ )
Negative Supply Voltage, $V_{EE}$	-4.6V (ECL mode, $V_{CC} = 0$ )
Inputs, $V_I$ (LVPECL mode)	-0.5V to $V_{CC} + 0.5V$
Inputs, $V_I$ (ECL mode)	0.5V to $V_{EE} - 0.5V$
Outputs, $I_O$	
Continuous Current	50mA
Surge Current	100mA
Operating Temperature Range, $T_A$	-40°C to +85°C
Storage Temperature, $T_{STG}$	-65°C to 150°C
Package Thermal Impedance, $\theta_{JA}$ (Junction-to-Ambient)	51.5°C/W (0 lfpm)

**NOTE:** Stresses beyond those listed under Absolute Maximum Ratings may cause permanent damage to the device. These ratings are stress specifications only. Functional operation of product at these conditions or any conditions beyond those listed in the *DC Characteristics* or *AC Characteristics* is not implied. Exposure to absolute maximum rating conditions for extended periods may affect product reliability.

**TABLE 4A. POWER SUPPLY DC CHARACTERISTICS,  $V_{CC} = 2.375V$  TO  $3.465V$ ,  $V_{EE} = 0V$  OR  $V_{CC} = 0V$ ,  $V_{EE} = -3.465V$  TO  $-2.375V$**

Symbol	Parameter	Test Conditions	Minimum	Typical	Maximum	Units
$V_{CC}$	Positive Supply Voltage		3.135	3.3	3.465	V
			2.375	2.5	2.625	V
$I_{EE}$	Power Supply Current			40		mA

**TABLE 4B. LVC MOS / LV TTL DC CHARACTERISTICS,  $V_{CC} = 2.375V$  TO  $3.465V$**

Symbol	Parameter	Test Conditions	Minimum	Typical	Maximum	Units
$V_{IH}$	Input High Voltage	$V_{CC} = 3.3V$	2		$V_{CC} + 0.3$	V
		$V_{CC} = 2.625V$	1.7		$V_{CC} + 0.3$	V
$V_{IL}$	Input Low Voltage	$V_{CC} = 3.3V$	0		0.8	V
		$V_{CC} = 2.625V$	0		0.7	V
$I_{IH}$	Input High Current	SELA, SELB $V_{CC} = V_{IN} = 3.465V$ , $V_{CC} = V_{IN} = 2.625V$			150	$\mu A$
$I_{IL}$	Input Low Current	SELA, SELB $V_{CC} = 3.465$ or $2.625V$ , $V_{IN} = 0V$	-150			$\mu A$



**TABLE 4C. LVPECL DC CHARACTERISTICS,  $V_{CC} = 3.3V$ ,  $V_{EE} = 0V$**

Symbol	Parameter	-40°C			25°C			85°C			Units
		Min	Typ	Max	Min	Typ	Max	Min	Typ	Max	
$V_{OH}$	Output High Voltage; NOTE 1	$V_{CC}-1.125$	$V_{CC}-1.025$	$V_{CC}-0.92$	$V_{CC}-1.075$	$V_{CC}-1.005$	$V_{CC}-0.93$	$V_{CC}-1.005$	$V_{CC}-0.97$	$V_{CC}-0.935$	V
$V_{OL}$	Output Low Voltage; NOTE 1	$V_{CC}-1.895$	$V_{CC}-1.755$	$V_{CC}-1.62$	$V_{CC}-1.875$	$V_{CC}-1.78$	$V_{CC}-1.685$	$V_{CC}-1.86$	$V_{CC}-1.765$	$V_{CC}-1.67$	V
$V_{PP}$	Peak-to-Peak Input Voltage	150	800	1200	150	800	1200	150	800	1200	mV
$V_{CMR}$	Input High Voltage Common Mode Range; NOTE 2, 3	1.2		$V_{CC}$	1.2		$V_{CC}$	1.2		$V_{CC}$	V
$I_{IH}$	Input High Current			150			150			150	$\mu A$
$I_{IL}$	Input Low Current	INAx, INB	-10		-10			-10			$\mu A$
		nINAx, nINB	-150		-150			-150			$\mu A$

Input and output parameters vary 1:1 with  $V_{CC}$ .  $V_{CC}$  can vary +0.165V to -0.925V.

NOTE 1: Outputs terminated with  $50\Omega$  to  $V_{CC} - 2V$ .

NOTE 2: Common mode voltage is defined as  $V_{IH}$ .

NOTE 3: For single-ended applications, the maximum input voltage for INAx, nINAx and INB, nINB is  $V_{CC} + 0.3V$ .

**TABLE 4D. ECL DC CHARACTERISTICS,  $V_{EE} = -3.465V$  TO  $-2.375V$ ,  $V_{CC} = 0V$**

Symbol	Parameter	-40°C			25°C			85°C			Units
		Min	Typ	Max	Min	Typ	Max	Min	Typ	Max	
$V_{OH}$	Output High Voltage; NOTE 1	-1.125	-1.025	-0.92	-1.075	-1.005	-0.93	-1.005	-0.97	-0.935	V
$V_{OL}$	Output Low Voltage; NOTE 1	-1.895	-1.755	-1.62	-1.875	-1.78	-1.685	-1.86	-1.765	-1.67	V
$V_{PP}$	Peak-to-Peak Input Voltage	150	800	1200	150	800	1200	150	800	1200	mV
$V_{CMR}$	Input High Voltage Common Mode Range; NOTE 2, 3	$V_{EE}+1.2V$		$V_{CC}$	$V_{EE}+1.2V$		$V_{CC}$	$V_{EE}+1.2V$		$V_{CC}$	V
$I_{IH}$	Input High Current			150			150			150	$\mu A$
$I_{IL}$	Input Low Current	INAx, INB	-10		-10			-10			$\mu A$
		nINAx, nINB	-150		-150			-150			$\mu A$

Input and output parameters vary 1:1 with  $V_{CC}$ .

NOTE 1: Outputs terminated with  $50\Omega$  to  $V_{CC} - 2V$ .

NOTE 2: Common mode voltage is defined as  $V_{IH}$ .

NOTE 3: For single-ended applications, the maximum input voltage for INAx, nINAx and INB, nINB is  $V_{CC} + 0.3V$ .

**TABLE 5. AC CHARACTERISTICS,  $V_{CC} = 2.375V$  TO  $3.465V$ ,  $V_{EE} = 0V$  OR  $V_{CC} = 0V$ ,  $V_{EE} = -3.465V$  TO  $-2.375V$** 

Symbol	Parameter	Conditions	Minimum	Typical	Maximum	Units
$f_{MAX}$	Output Frequency				2.5	GHz
$t_{PD}$	Propagation Delay; NOTE 1			440		ps
$t_{sk(pp)}$	Part-to-Part Skew; NOTE 3, 4			85		ps
$f_{jit}$	Buffer Additive Phase Jitter, RMS; refer to Additive Phase Jitter section	622.08MHz (12kHz - 20MHz)		0.05		ps
	MUX Isolation			55		dB
$t_R/t_F$	Output Rise/Fall Time	20% to 80%		170		ps

All parameters are measured  $\leq 1.3GHz$  unless otherwise noted.

NOTE 1: Measured from the differential input crossing point to the differential output crossing point.

NOTE 2: Defined as skew between outputs at the same supply voltage and with equal load conditions.

Measured at the output differential cross points.

NOTE 3: Defined as skew between outputs on different devices operating at the same supply voltages and with equal load conditions. Using the same type of inputs on each device, the outputs are measured at the differential cross points.

NOTE 4: This parameter is defined in accordance with JEDEC Standard 65.



ADDITIVE PHASE JITTER

The spectral purity in a band at a specific offset from the fundamental compared to the power of the fundamental is called the **dBc Phase Noise**. This value is normally expressed using a Phase noise plot and is most often the specified plot in many applications. Phase noise is defined as the ratio of the noise power present in a 1Hz band at a specified offset from the fundamental frequency to the power value of the fundamental. This ratio is expressed in decibels (dBm) or a

ratio of the power in the 1Hz band to the power in the fundamental. When the required offset is specified, the phase noise is called a **dBc** value, which simply means dBm at a specified offset from the fundamental. By investigating jitter in the frequency domain, we get a better understanding of its effects on the desired application over the entire time record of the signal. It is mathematically possible to calculate an expected bit error rate given a phase noise plot.

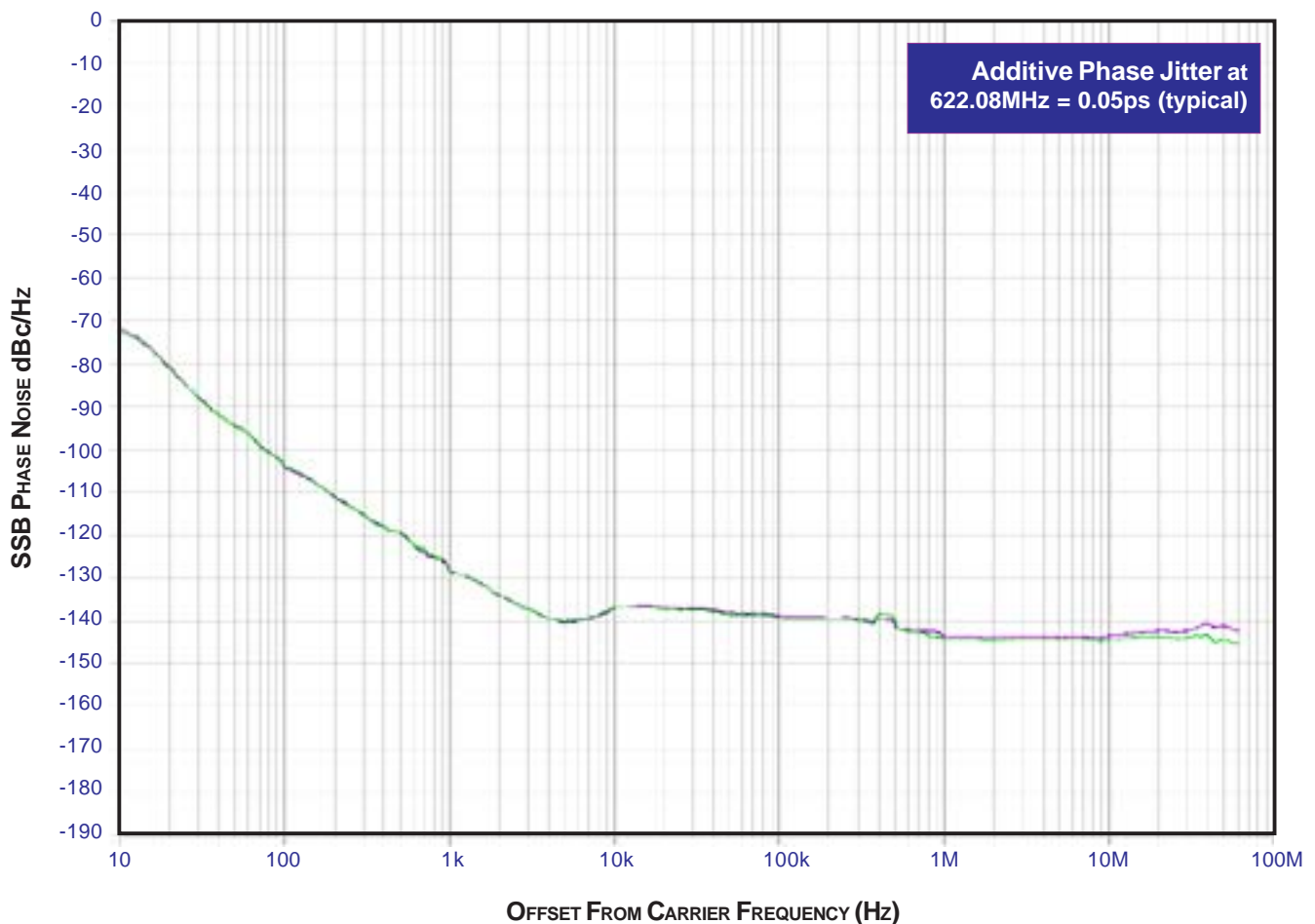

As with most timing specifications, phase noise measurements have issues. The primary issue relates to the limitations of the equipment. Often the noise floor of the equipment is higher than the noise floor of the device. This is illustrated

above. The device meets the noise floor of what is shown, but can actually be lower. The phase noise is dependant on the input source and measurement equipment.



PARAMETER MEASUREMENT INFORMATION

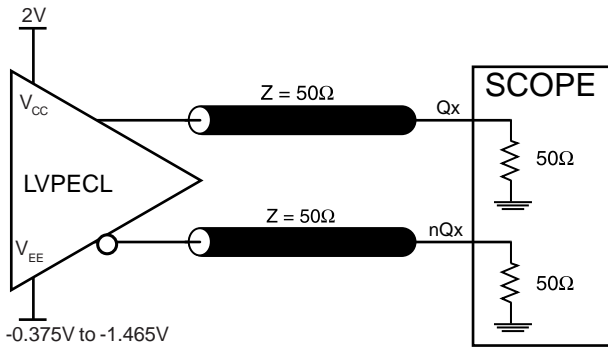

OUTPUT LOAD AC TEST CIRCUIT

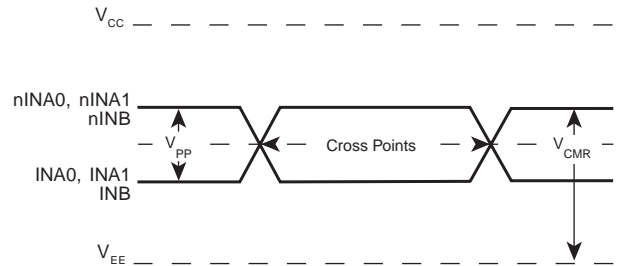

DIFFERENTIAL INPUT LEVEL

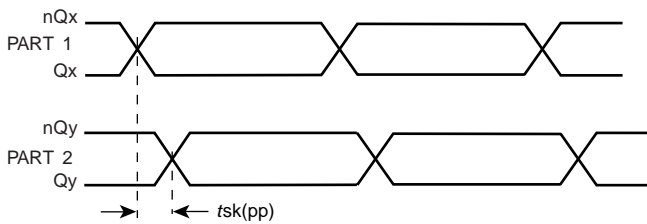

PART-TO-PART SKEW

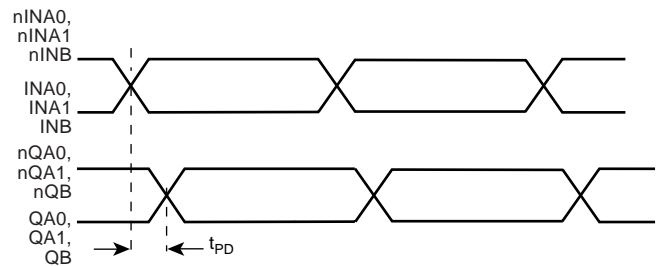

PROPAGATION DELAY

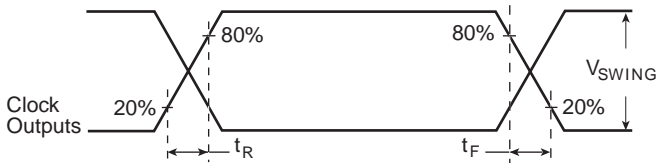

OUTPUT RISE/FALL TIME

**APPLICATION INFORMATION**

**WIRING THE DIFFERENTIAL INPUT TO ACCEPT SINGLE ENDED LEVELS**

Figure 1 shows how the differential input can be wired to accept single ended levels. The reference voltage  $V_{REF} = V_{CC}/2$  is generated by the bias resistors R1, R2 and C1. This bias circuit should be located as close as possible to the input pin. The ratio

of R1 and R2 might need to be adjusted to position the  $V_{REF}$  in the center of the input voltage swing. For example, if the input clock swing is only 2.5V and  $V_{CC} = 3.3V$ ,  $V_{REF}$  should be 1.25V and  $R2/R1 = 0.609$ .

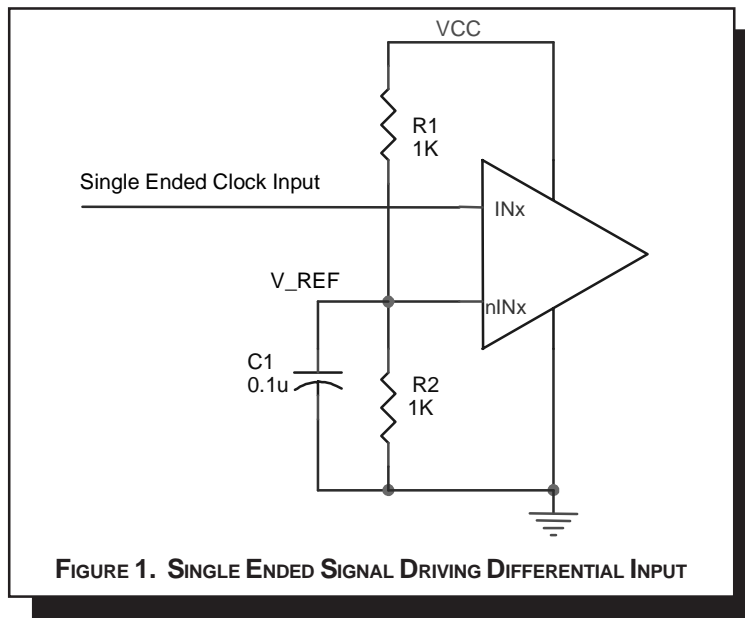

**RECOMMENDATIONS FOR UNUSED INPUT AND OUTPUT PINS**

**INPUTS:**

**In/nIn INPUT:**

For applications not requiring the use of the differential input, both IN and nIN can be left floating. Though not required, but for additional protection, a 1kΩ resistor can be tied from IN to ground.

**LVC MOS CONTROL PINS:**

All control pins have internal pull-ups or pull-downs; additional resistance is not required but can be added for additional protection. A 1kΩ resistor can be used.

**OUTPUTS:**

**LVPECL OUTPUT**

All unused LVPECL outputs can be left floating. We recommend that there is no trace attached. Both sides of the differential output pair should either be left floating or terminated.

**LVPECL(DIFFERENTIAL) CLOCK INPUT INTERFACE**

The IN/nIN accepts LVPECL, CML, SSTL and other differential signals. Both  $V_{SWING}$  and  $V_{OH}$  must meet the  $V_{PP}$  and  $V_{CMR}$  input requirements. Figures 2A to 2F show interface examples for the HiPerClockS IN/nIN input driven by the most common driver types. The input interfaces suggested here

are examples only. If the driver is from another vendor, use their termination recommendation. Please consult with the vendor of the driver component to confirm the driver termination requirements.

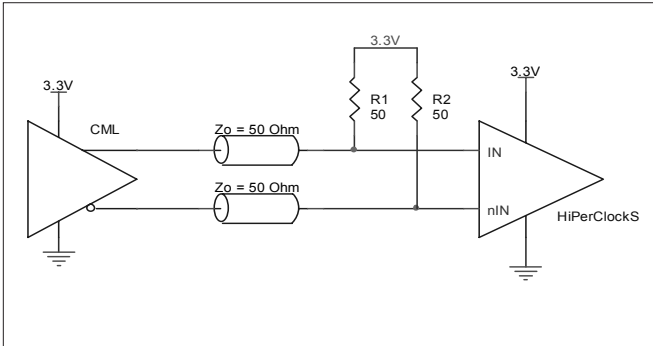

**FIGURE 2A. HiPerClockS IN/nIN INPUT DRIVEN BY AN OPEN COLLECTOR CML DRIVER**

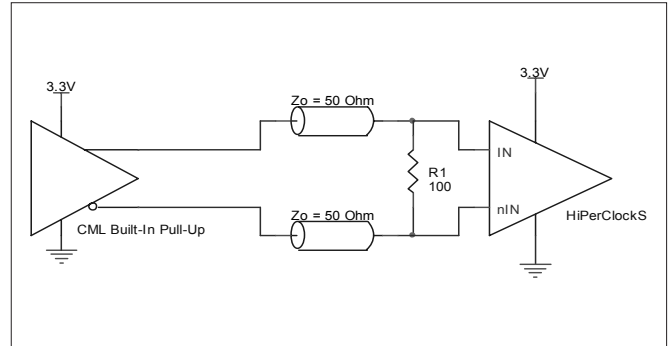

**FIGURE 2B. HiPerClockS IN/nIN INPUT DRIVEN BY A BUILT-IN PULLUP CML DRIVER**

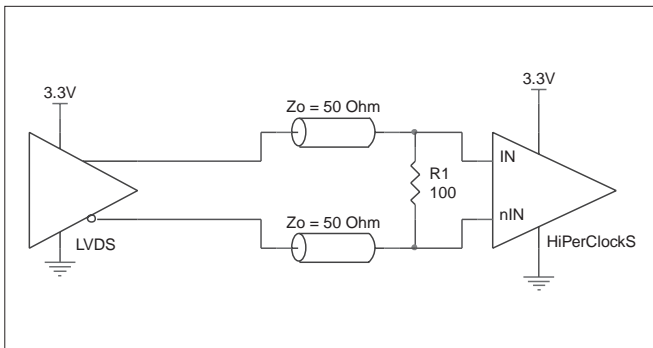

**FIGURE 2C. HiPerClockS IN/nIN INPUT DRIVEN BY A 3.3V LVPECL DRIVER**

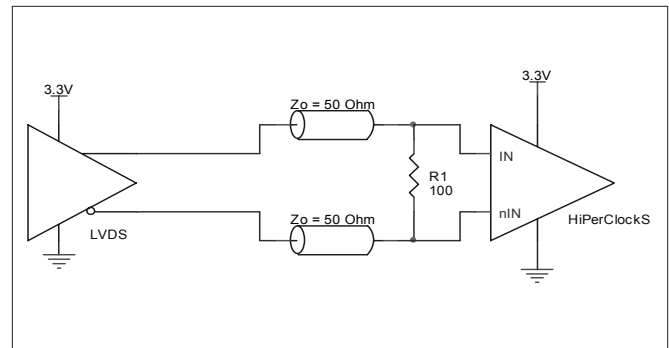

**FIGURE 2D. HiPerClockS IN/nIN INPUT DRIVEN BY A 3.3V LVDS DRIVER**

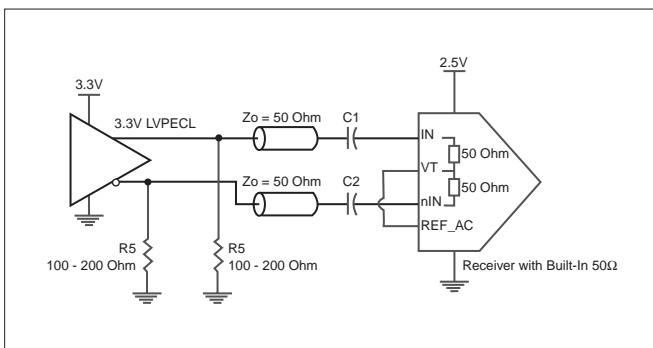

**FIGURE 2E. HiPerClockS IN/nIN INPUT WITH BUILT-IN 50Ω DRIVEN BY A 3.3V LVPECL DRIVER**

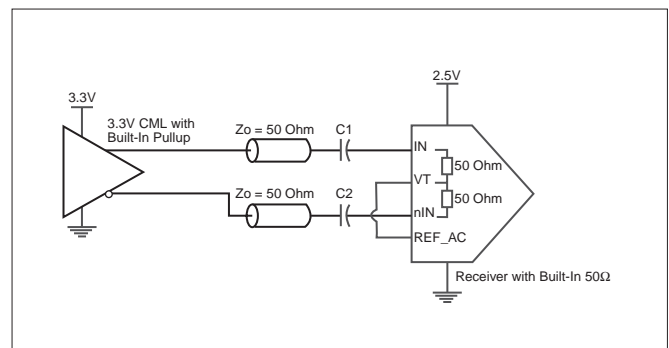

**FIGURE 2F. HiPerClockS IN/nIN INPUT WITH BUILT-IN 50Ω DRIVEN BY A 3.3V CML DRIVER WITH BUILT-IN PULLUP**

**TERMINATION FOR 3.3V LVPECL OUTPUTS**

The clock layout topology shown below is a typical termination for LVPECL outputs. The two different layouts mentioned are recommended only as guidelines.

FOUT and nFOUT are low impedance follower outputs that generate ECL/LVPECL compatible outputs. Therefore, terminating resistors (DC current path to ground) or current sources must be used for functionality. These outputs are designed to drive 50Ω transmission lines. Matched imped-

ance techniques should be used to maximize operating frequency and minimize signal distortion. *Figures 3A and 3B* show two different layouts which are recommended only as guidelines. Other suitable clock layouts may exist and it would be recommended that the board designers simulate to guarantee compatibility across all printed circuit and clock component process variations.

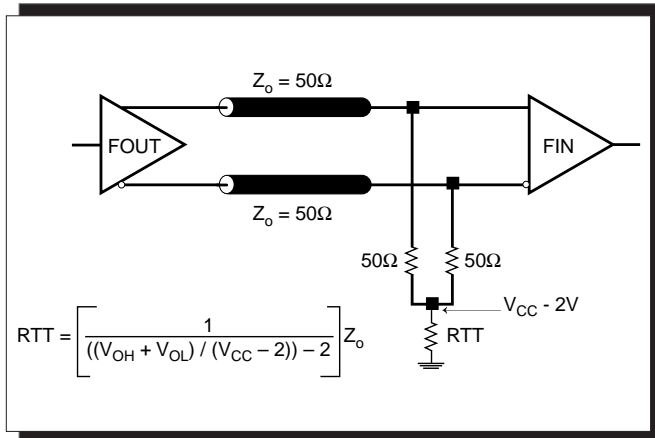

FIGURE 3A. LVPECL OUTPUT TERMINATION

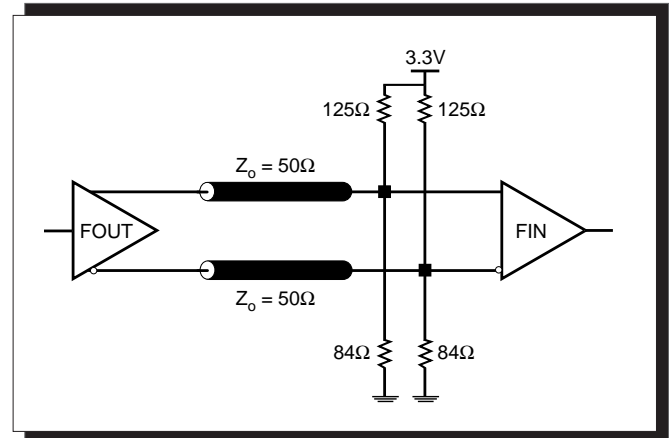

FIGURE 3B. LVPECL OUTPUT TERMINATION



**TERMINATION FOR 2.5V LVPECL OUTPUT**

Figure 4A and Figure 4B show examples of termination for 2.5V LVPECL driver. These terminations are equivalent to terminating 50Ω to  $V_{CC} - 2V$ . For  $V_{CC} = 2.5V$ , the  $V_{CC} - 2V$  is very

close to ground level. The R3 in Figure 4B can be eliminated and the termination is shown in Figure 4C.

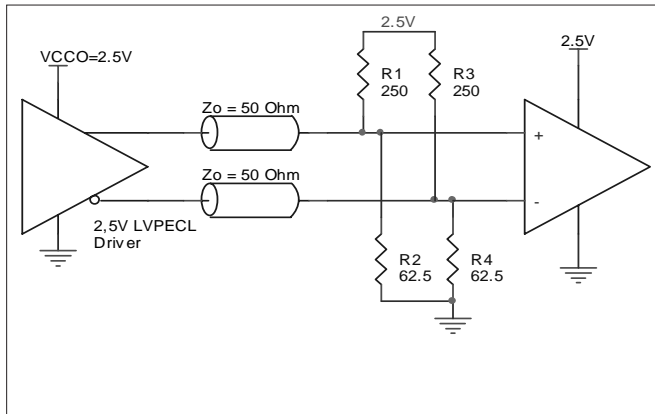

FIGURE 4A. 2.5V LVPECL DRIVER TERMINATION EXAMPLE

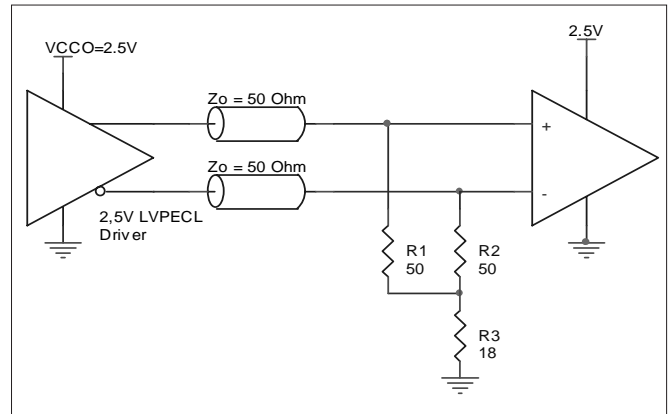

FIGURE 4B. 2.5V LVPECL DRIVER TERMINATION EXAMPLE

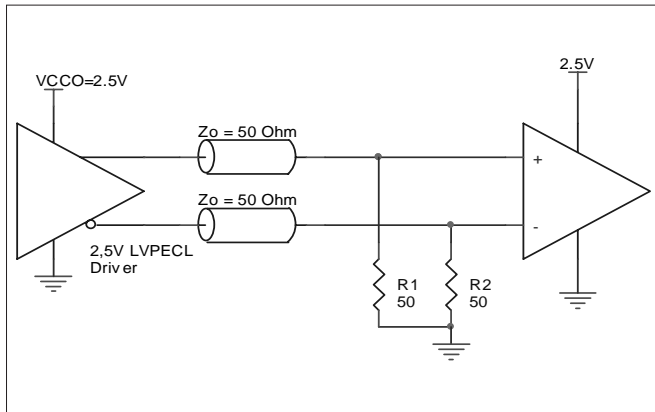

FIGURE 4C. 2.5V LVPECL TERMINATION EXAMPLE



## POWER CONSIDERATIONS

This section provides information on power dissipation and junction temperature for the ICS85354-01. Equations and example calculations are also provided.

### 1. Power Dissipation.

The total power dissipation for the ICS85354-01 is the sum of the core power plus the power dissipated in the load(s). The following is the power dissipation for  $V_{CC} = 3.465V$ , which gives worst case results.

**NOTE:** Please refer to Section 3 for details on calculating power dissipated in the load.

- Power (core)<sub>MAX</sub> =  $V_{CC\_MAX} * I_{EE\_MAX} = 3.465V * 40mA = 138.6mW$
- Power (outputs)<sub>MAX</sub> = **30.92mW/Loaded Output pair**  
If all outputs are loaded, the total power is  $3 * 30.92mW = 92.76mW$

**Total Power**<sub>MAX</sub> (3.465, with all outputs switching) =  $138.6mW + 92.76mW = 231.4mW$

### 2. Junction Temperature.

Junction temperature,  $T_j$ , is the temperature at the junction of the bond wire and bond pad and directly affects the reliability of the device. The maximum recommended junction temperature for HiPerClockS™ devices is 125°C.

The equation for  $T_j$  is as follows:  $T_j = \theta_{JA} * Pd\_total + T_A$

$T_j$  = Junction Temperature

$\theta_{JA}$  = Junction-to-Ambient Thermal Resistance

$Pd\_total$  = Total Device Power Dissipation (example calculation is in section 1 above)

$T_A$  = Ambient Temperature

In order to calculate junction temperature, the appropriate junction-to-ambient thermal resistance  $\theta_{JA}$  must be used. Assuming 0 air flow and a multi-layer board, the appropriate value is 51.5°C/W per Table 6 below.

Therefore,  $T_j$  for an ambient temperature of 85°C with all outputs switching is:

$85^\circ C + 0.231W * 51.5^\circ C/W = 96.9^\circ C$ . This is well below the limit of 125°C.

This calculation is only an example.  $T_j$  will obviously vary depending on the number of loaded outputs, supply voltage, air flow, and the type of board (single layer or multi-layer).

**TABLE 6. THERMAL RESISTANCE  $\theta_{JA}$  FOR 16-PIN VFQFN, FORCED CONVECTION**

$\theta_{JA}$ vs. 0 Air Flow (Linear Feet per Minute)	
0	
Multi-Layer PCB, JEDEC Standard Test Boards	51.5°C/W

3. Calculations and Equations.

The purpose of this section is to derive the power dissipated into the load.

LVPECL output driver circuit and termination are shown in *Figure 5*.

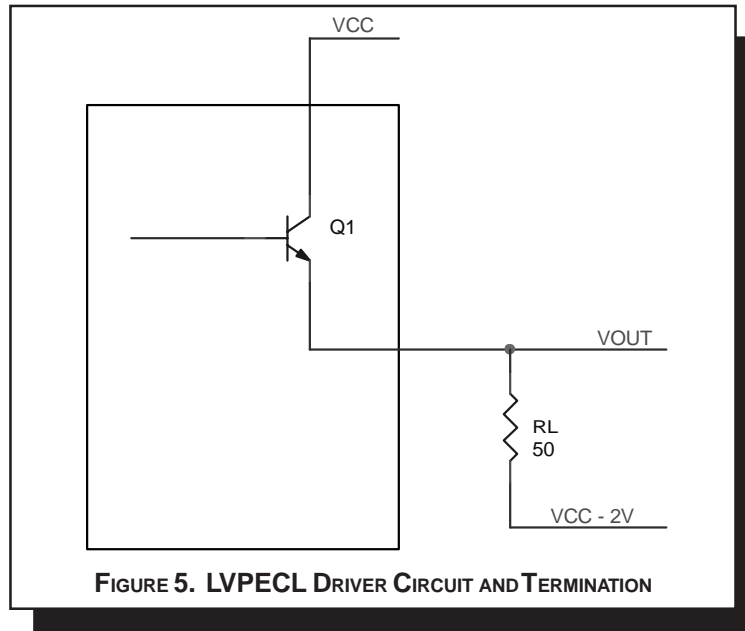

To calculate worst case power dissipation into the load, use the following equations which assume a 50Ω load, and a termination voltage of  $V_{CC} - 2V$ .

- For logic high,  $V_{OUT} = V_{OH\_MAX} = V_{CC\_MAX} - 0.935V$   
 $(V_{CC\_MAX} - V_{OH\_MAX}) = 0.935$
- For logic low,  $V_{OUT} = V_{OL\_MAX} = V_{CC\_MAX} - 1.67V$   
 $(V_{CC\_MAX} - V_{OL\_MAX}) = 1.67V$

$Pd\_H$  is power dissipation when the output drives high.  
 $Pd\_L$  is the power dissipation when the output drives low.

$$Pd\_H = [(V_{OH\_MAX} - (V_{DD\_MAX} - 2V))/R_L] * (V_{CC\_MAX} - V_{OH\_MAX}) = [(2V - (V_{CC\_MAX} - V_{OH\_MAX}))/R_L] * (V_{CC\_MAX} - V_{OH\_MAX}) = [(2V - 0.935V)/50\Omega] * 0.935V = 19.92mW$$

$$Pd\_L = [(V_{OL\_MAX} - (V_{CC\_MAX} - 2V))/R_L] * (V_{CC\_MAX} - V_{OL\_MAX}) = [(2V - (V_{CC\_MAX} - V_{OL\_MAX}))/R_L] * (V_{CC\_MAX} - V_{OL\_MAX}) = [(2V - 1.67V)/50\Omega] * 1.67V = 11.02mW$$

Total Power Dissipation per output pair =  $Pd\_H + Pd\_L = 30.92mW$



**RELIABILITY INFORMATION**

TABLE 7.  $\theta_{JA}$  vs. AIR FLOW TABLE FOR 16 LEAD VFQFN

$\theta_{JA}$ at 0 Air Flow (Linear Feet per Minute)	
Multi-Layer PCB, JEDEC Standard Test Boards	0 51.5°C/W

**TRANSISTOR COUNT**

The transistor count for ICS85354-01 is: 210



**PRELIMINARY**

**ICS85354-01**

DUAL 2:1/1:2

DIFFERENTIAL-TO-LVPECL/ECL MULTIPLEXER

PACKAGE OUTLINE - K SUFFIX FOR 16 LEAD VFQFN

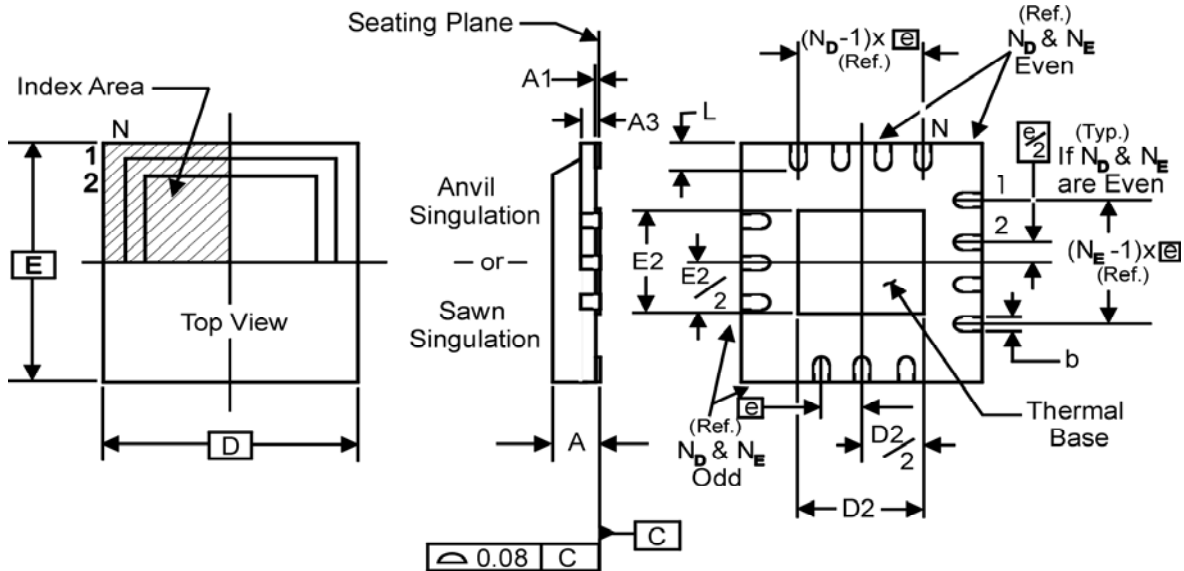

TABLE 8. PACKAGE DIMENSIONS

JEDEC VARIATION ALL DIMENSIONS IN MILLIMETERS		
SYMBOL	MINIMUM	MAXIMUM
N	16	
A	0.80	1.0
A1	0	0.05
A3	0.25 Reference	
b	0.18	0.30
e	0.50 BASIC	
N <sub>D</sub>	4	
N <sub>E</sub>	4	
D	3.0	
D2	0.25	1.25
E	3.0	
E2	0.25	1.25
L	0.30	0.50

Reference Document: JEDEC Publication 95, MO-220



**TABLE 9. ORDERING INFORMATION**

Part/Order Number	Marking	Package	Shipping Packaging	Temperature
ICS85354AK-01	4A01	16 Lead VFQFN	Tube	-40°C to 85°C
ICS85354AK-01T	4A01	16 Lead VFQFN	2500 Tape & Reel	-40°C to 85°C
ICS85354AK-01LF	A01L	16 Lead "Lead-Free" VFQFN	Tube	-40°C to 85°C
ICS85354AK-01LFT	A01L	16 Lead "Lead-Free" VFQFN	2500 Tape & Reel	-40°C to 85°C

NOTE: Parts that are ordered with an "LF" suffix to the part number are the Pb-free configuration and are RoHS compliant.

While the information presented herein has been checked for both accuracy and reliability, Integrated Device Technology, Incorporated (IDT) assumes no responsibility for either its use or for infringement of any patents or other rights of third parties, which would result from its use. No other circuits, patents, or licenses are implied. This product is intended for use in normal commercial applications. Any other applications such as those requiring extended temperature ranges, high reliability or other extraordinary environmental requirements are not recommended without additional processing by IDT. IDT reserves the right to change any circuitry or specifications without notice. IDT does not authorize or warrant any IDT product for use in life support devices or critical medical instruments.

## Looking for pricing, stock, or lifecycle information?

Click below to explore more details on WIN SOURCE:

-  [View 85354AK-01LFT on WIN SOURCE](#)
-  [IDT, Integrated Device Technology Inc Information](#)

## Optimize Your Supply Chain with WIN SOURCE Solutions

-  Global Sourcing Solution
-  Obsolete Management
-  Cost Control Management
-  Shortage Management
-  Alternative Solution
-  Excess Inventory Management