



# THE DATASHEET OF TEA2025B



## STEREO AUDIO AMPLIFIER

### 1 FEATURES

- DUAL OR BRIDGE CONNECTION MODES
- FEW EXTERNAL COMPONENTS
- SUPPLY VOLTAGE DOWN TO 3V
- HIGH CHANNEL SEPARATION
- VERY LOW SWITCH ON/OFF NOISE
- MAX GAIN OF 45dB WITH ADJUST EXTERNAL RESISTOR
- SOFT CLIPPING
- THERMAL PROTECTION
- $3V < V_{CC} < 15V$
- $P = 2 \cdot 1W, V_{CC} = 6V, R_L = 4\Omega$
- $P = 2 \cdot 2.3W, V_{CC} = 9V, R_L = 4\Omega$
- $P = 2 \cdot 0.1W, V_{CC} = 3V, R_L = 4\Omega$

Figure 1. Package



Table 1. Order Codes

Part Number	Package
TEA2025B	PowerDIP 12+2+2
TEA2025D	SO20 12+4+4
TEA2025D013TR	SO16 in Tape & Reel

### 2 DESCRIPTION

The TEA2025B/D is a monolithic integrated circuit in 12+2+2 Powerdip and 12+4+4 SO, intended for use as dual or bridge power audio amplifier portable radio cassette players.

Figure 2. Block Diagram

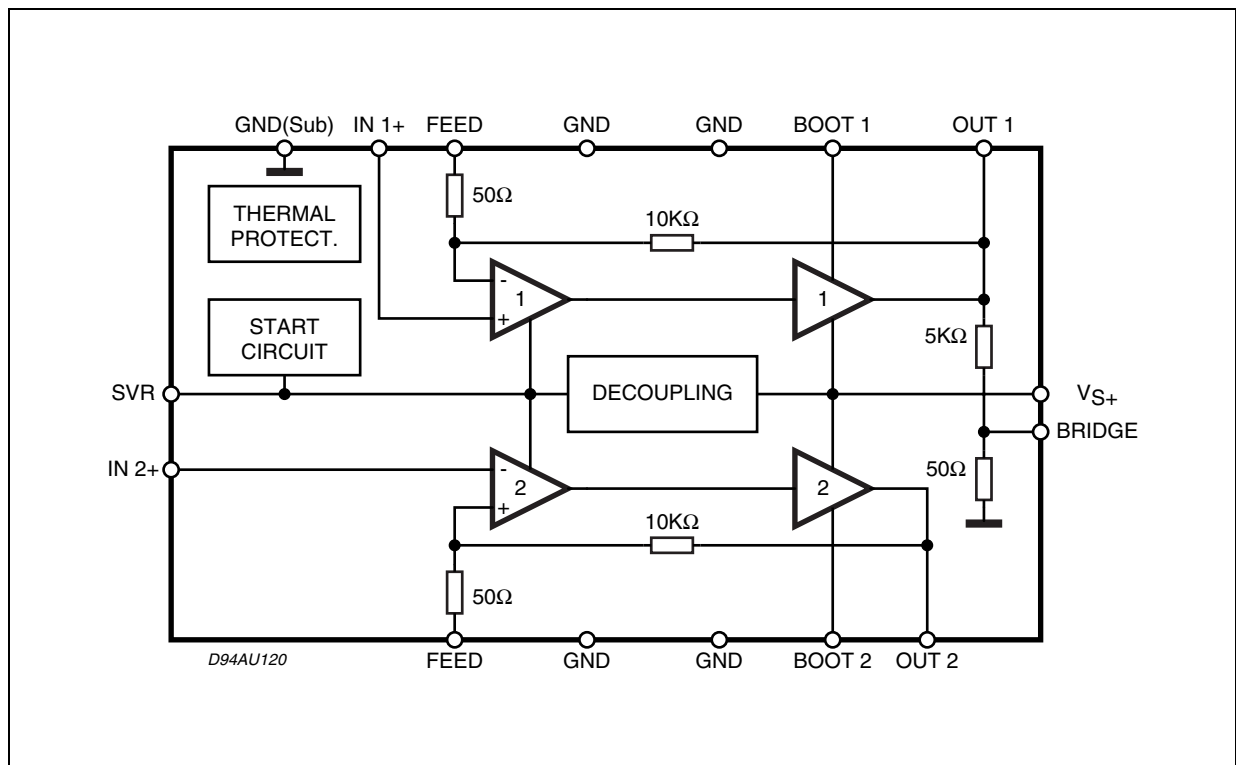

**Table 2. Absolute Maximum Ratings**

Symbol	Parameter	Value	Unit
V <sub>S</sub>	Supply Voltage	15	V
I <sub>O</sub>	Output Peak Current	1.5	A
T <sub>J</sub>	Junction Temperature	150	°C
T <sub>stg</sub>	Storage Temperature	150	°C

**Figure 3. PIN CONNECTION POWERDIP12+2+2**

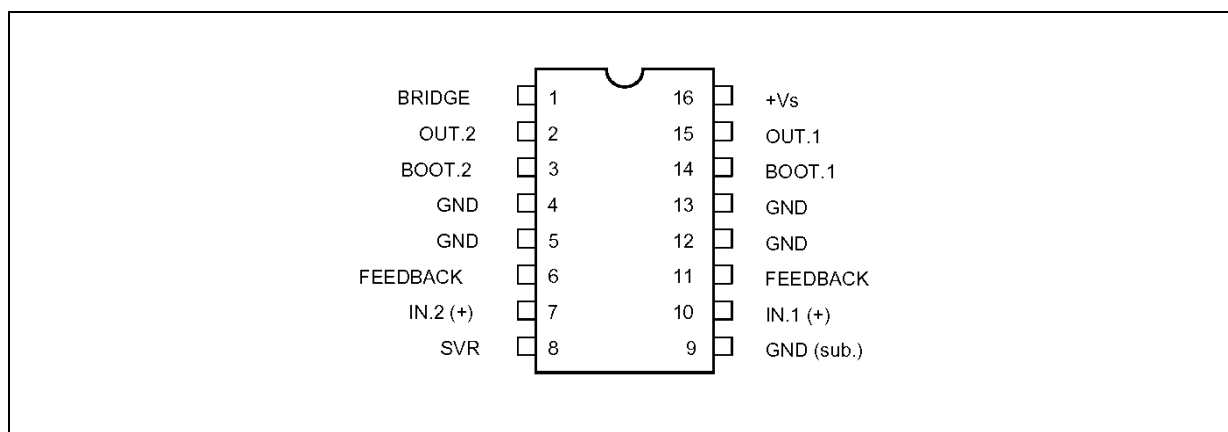

**Figure 4. PIN CONNECTION SO12+4+4**

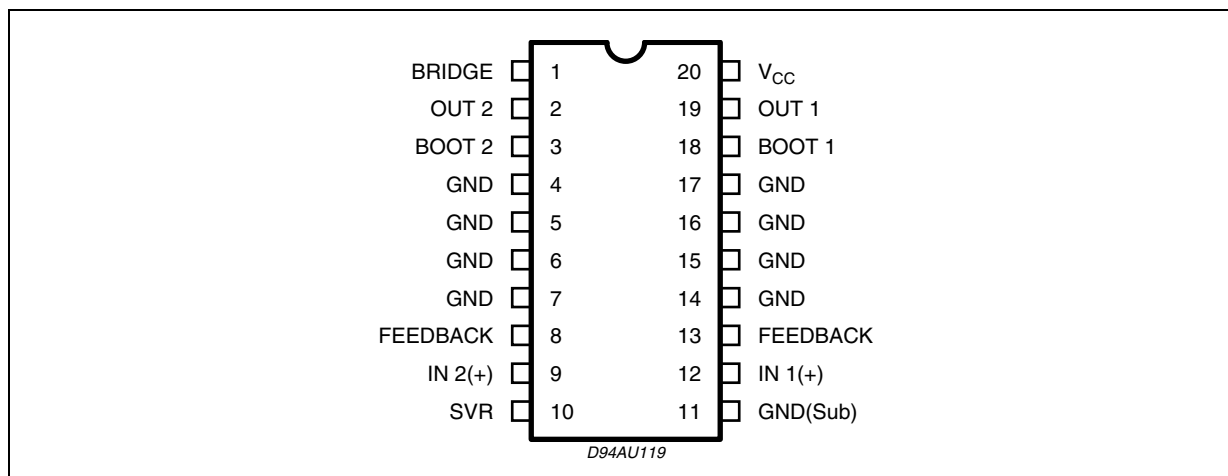

**Table 3. Thermal Data**

Symbol	Description		SO 12+4+4 <sup>(1)</sup>	PDIP 12+2+2 <sup>(2)</sup>	Unit
R <sub>th j-case</sub>	Thermal Resistance Junction-case	Max	15	15	°C/W
R <sub>th j-amb</sub>	Thermal Resistance Junction-ambient	Max	65	60	°C/W

Note: 1. The R<sub>th j-amb</sub> is measured with 4sq cm copper area heatsink  
 2. The R<sub>th j-amb</sub> is measured on devices bonded on a 10 x 5 x 0.15cm glass-epoxy substrate with a 35µm thick copper surface of 5 cm<sup>2</sup>

**Table 4. Electrical Characteristics** ( $T_{amb} = 25^{\circ}\text{C}$ ,  $V_{CC} = 9\text{V}$ , Stereo unless otherwise specified)

Symbol	Parameter	Test Conditions	Min.	Typ.	Max.	Unit	
$V_S$	Supply Voltage		3		12	V	
$I_Q$	Quiescent Current			35	50	mA	
$V_O$	Quiescent Output Voltage			4.5		V	
$A_V$	Voltage Gain	Stereo	43	45	47	dB	
		Bridge	49	51	53	dB	
$\Delta A_V$	Voltage Gain Difference				$\pm 1$	dB	
$R_i$	Input Impedance			30		K $\Omega$	
$P_O$	Output Power (d = 10%)	Stereo 8 (per channel)	9V 4 $\Omega$	1.7	2.3		W
			9V 8 $\Omega$		1.3		W
			6V 4 $\Omega$	0.7	1		W
			6V 8 $\Omega$		0.6		W
			6V 16 $\Omega$		0.25		W
			6V 32 $\Omega$		0.13		W
			3V 4 $\Omega$		0.1		W
		Bridge	3V 32 $\Omega$		0.02		W
			12V 8 $\Omega$		2.4		W
			9V 8 $\Omega$		4.7		W
			6V 4 $\Omega$		2.8		W
			6V 8 $\Omega$		1.5		W
			3V 16 $\Omega$		0.18		W
			3V 32 $\Omega$		0.06		W
d	Distortion	$V_S = 9\text{V}$ ; $R_L = 4\Omega$		0.3 0.5	1.5	%	
SVR	Supply Voltage Rejection	$f = 100\text{Hz}$ , $V_R = 0.5\text{V}$ , $R_g = 0$	40	46		dB	
$E_{N(IN)}$	Input Noise Voltage	$R_G = 0$		1.5	3	mV	
		$R_G = 10\text{K}\Omega$		3	6	mV	
CT	Cross-Talk	$f = 1\text{KHz}$ , $R_g = 10\text{K}\Omega$	40	52		dB	

**Table 5.**

Term. N° (PDIP)	1	2	3	4	5	6	7	8	9	10	11	12	13	14	15	16
DC VOLT (V)	0.04	4.5	8.9	0	0	0.6	0.04	8.5	0	0.04	0.6	0	0	8.9	4.5	9

Figure 5. Bridge Application (Powerdip)

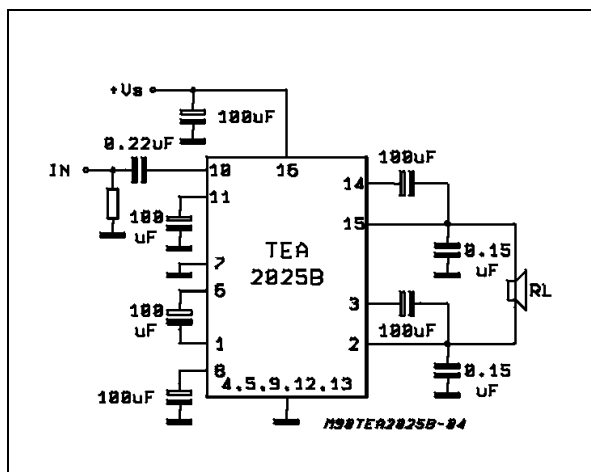

Figure 8. Output Voltage vs. Supply Voltage

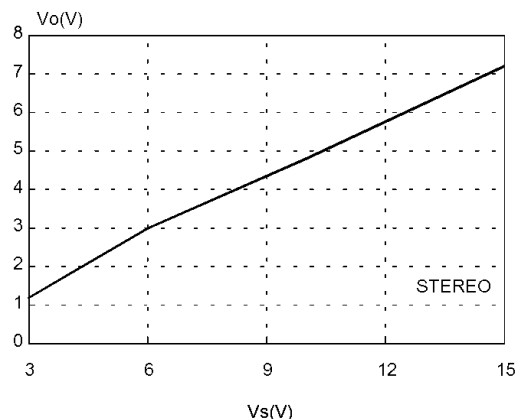

Figure 6. Stereo Application (Powerdip)

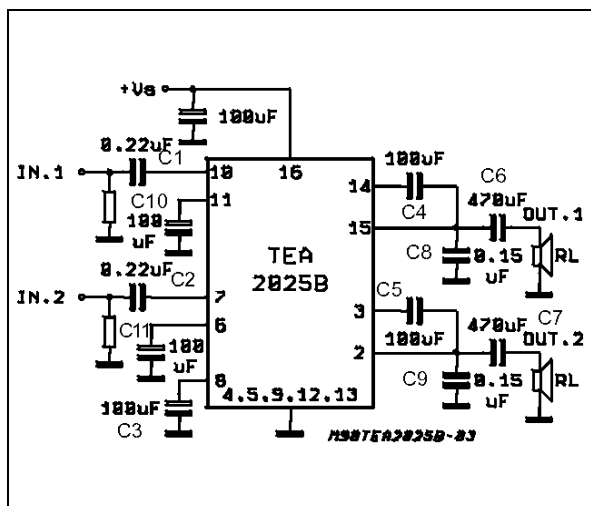

Figure 9. Output Power vs. Supply Voltage (THD = 10%, f = 1KHz)

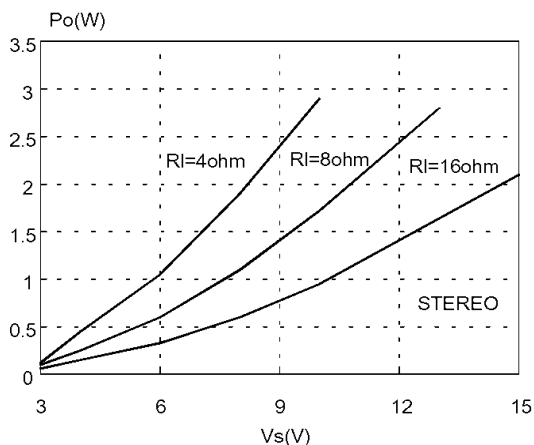

Figure 7. Supply Current vs. Supply Voltage (RL = 4Ω)

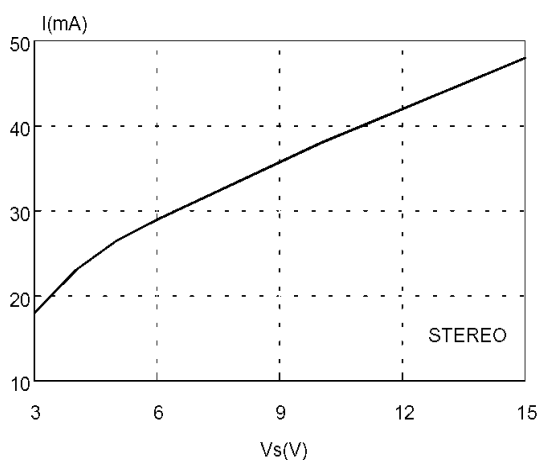
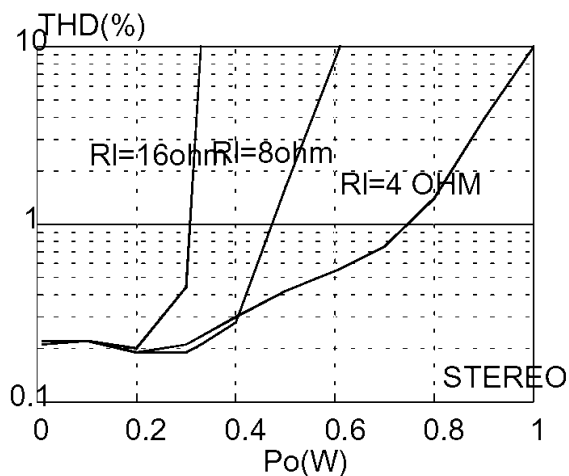

Figure 10. THD versus Output Power (f = 1KHz, VS = 6V)



### 3 APPLICATION INFORMATION

#### 3.1 Input Capacitor

Input capacitor is PNP type allowing source to be referenced to ground.

In this way no input coupling capacitor is required. However, a series capacitor (0.22  $\mu$ F) to the input side can be useful in case of noise due to variable resistor contact.

#### 3.2 Bootstrap

The bootstrap connection allows to increase the output swing.

The suggested value for the bootstrap capacitors (100 $\mu$ F) avoids a reduction of the output signal also at low frequencies and low supply voltages.

#### 3.3 Voltage Gain Adjust

##### 3.3.1 STEREO MODE

The voltage gain is determined by on-chip resistors R1 and R2 together with the external RfC1 series connected between pin 6 (11) and ground. The frequency response is given approximated

$$\frac{V_{OUT}}{V_{IN}} = \frac{R1}{Rf + R2 + \frac{1}{JWC1}}$$

With Rf=0, C1=100  $\mu$ F, the gain results 46 dB with pole at f=32 Hz.

THE purpose of Rf is to reduce the gain. It is recommended to not reduce it under 36 dB.

##### 3.3.2 BRIDGE MODE

Figure 11.

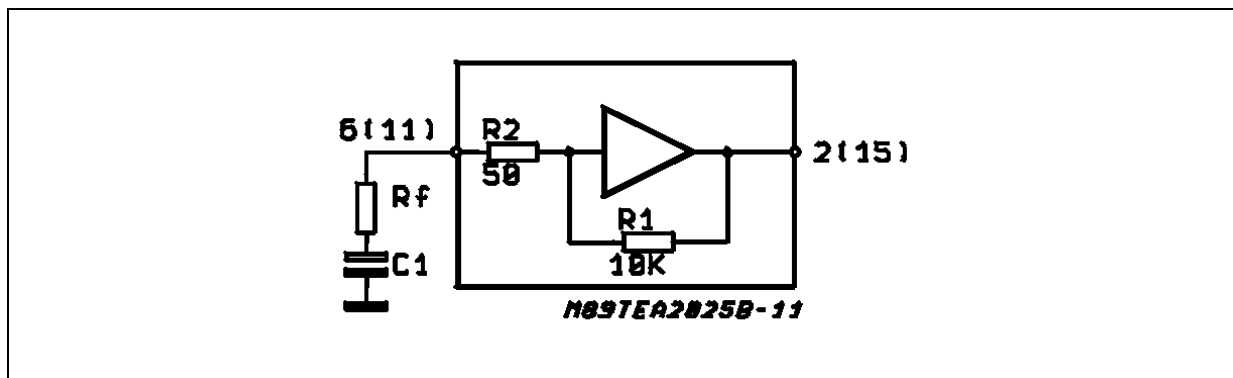

The bridge configuration is realized very easily thanks to an internal voltage divider which provides (at pin 1) the CH 1 output signal after reduction.

It is enough to connect pin 6 (inverting input of CH 2) with a capacitor to pin 1 and to connect to ground the pin 7. The total gain of the bridge is given by:

$$\frac{V_{OUT}}{V_{IN}} = \frac{R1}{Rf + R2 + \frac{1}{JWC1}} \left( 1 + \frac{R3}{R4} \frac{R1}{R2 + R4 + \frac{1}{JWC1}} \right)$$

and with the suggested values (C1 = C2 = 100  $\mu$ F, Rf= 0) means: Gv = 52 dB with first pole at f = 32 Hz

Figure 12.

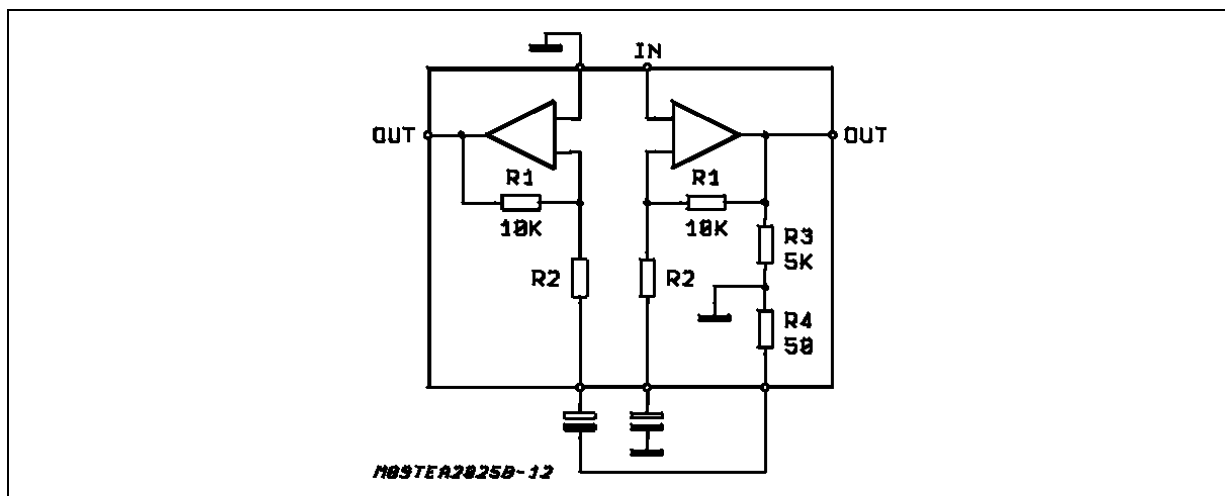

### 3.4 Output Capacitors.

The low cut off frequency due to output capacitor depending on the load is given by:  $F_L = \frac{1}{2\pi C_{OUT} \cdot R_L}$  with  $C_{OUT}$  470mF and  $R_L = 4$  ohm it means  $F_L = 80$  Hz.

### 3.5 Pop Noise

Most amplifiers similar to TEA 2025B need external resistors between DC outputs and ground in order to optimize the pop on/off performance and crossover distortion.

Figure 13.

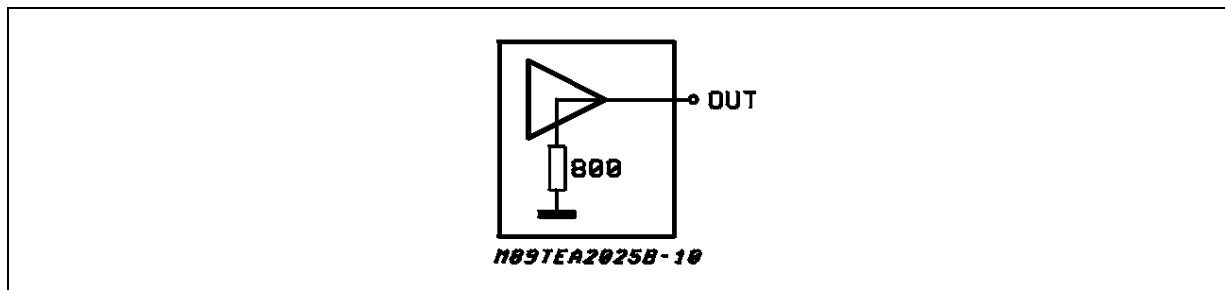

The TEA 2025B solution allows to save components because of such resistors (800 ohm) are included into the chip.

### 3.6 Stability

A good layout is recommended in order to avoid oscillations.

Generally the designer must pay attention on the following points:

- Short wires of components and short connections.
  - No ground loops.
  - Bypass of supply voltage with capacitors as nearest as possible to the supply I.C.pin. The low value (poliester) capacitors must have good temperature and frequency characteristics.
  - No sockets.
- the heatsink can have a smaller factor of safety compared with that of a conventional circuit. There is no device damage in the case of excessive junction temperature: all that happens is that PO (and

therefore  $P_{tot}$ ) and  $I_d$  are reduced.

#### 4 APPLICATION SUGGESTION

The recommended values of the components are those shown on stereo application circuit of Fig. 6 different values can be used, the following table can help the designer.

Table 6.

COMPONENT	RECOMMENDED VALUE	PURPOSE	LARGER THAN	SMALLER THAN
C1,C2	0.22 $\mu$ F	INPUT DC DECOUPLING IN CASE OF SLIDER CONTACT NOISE OF VARIABLE RESISTOR		
C3	100 $\mu$ F	RIPPLE REJECTON		DEGRADATION OF SVR, INCREASE OF AT LOW FREQUENCY AND LOW VOLTAGE
C4,C5	100 $\mu$ F	BOOTSTRAP		
C6,C7	470 $\mu$ F	OUTPUT DC DECOUPLING		INCREASE OF LOW FREQUENCY CUTOFF
C8,C9	0.15 $\mu$ F	FREQUENCY STABILITY		DANGEROF OSCILLATIONS
C10, C11	100 $\mu$ F	INVERTING INPUT DC DECOUPLING		INCREASE OFLOW FREQUENCYCUTOFF

#### 5 PACKAGE MECHANICAL DATA

In order to meet environmental requirements, ST offers these devices in different grades of ECOPACK<sup>®</sup> packages, depending on their level of environmental compliance. ECOPACK<sup>®</sup> specifications, grade definitions and product status are available at: [www.st.com](http://www.st.com). ECOPACK<sup>®</sup> is an ST trademark.

Figure 14. SO20 Mechanical Data & Package Dimensions

DIM.	mm			inch		
	MIN.	TYP.	MAX.	MIN.	TYP.	MAX.
A	2.35		2.65	0.093		0.104
A1	0.10		0.30	0.004		0.012
B	0.33		0.51	0.013		0.200
C	0.23		0.32	0.009		0.013
D (1)	12.60		13.00	0.496		0.512
E	7.40		7.60	0.291		0.299
e		1.27			0.050	
H	10.0		10.65	0.394		0.419
h	0.25		0.75	0.010		0.030
L	0.40		1.27	0.016		0.050
k	0° (min.), 8° (max.)					
ddd			0.10			0.004

(1) "D" dimension does not include mold flash, protusions or gate burrs. Mold flash, protusions or gate burrs shall not exceed 0.15mm per side.

**OUTLINE AND MECHANICAL DATA**

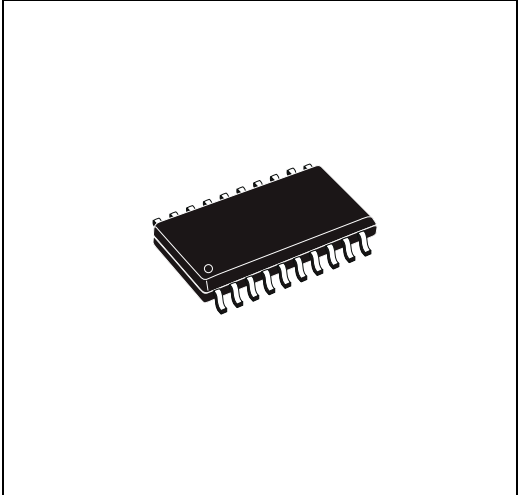

**SO20**

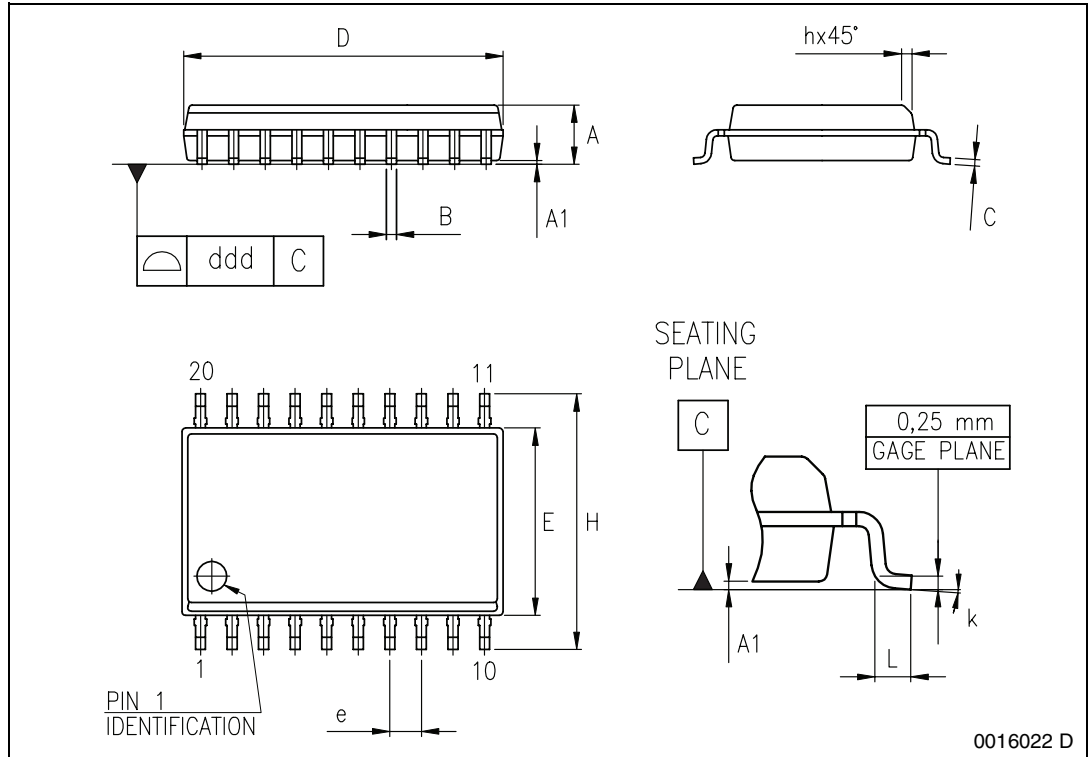
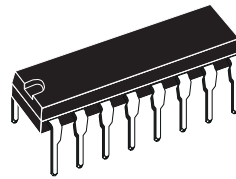

Figure 15. DIP16 Mechanical Data &amp; Package Dimensions

DIM.	mm			inch		
	MIN.	TYP.	MAX.	MIN.	TYP.	MAX.
a1	0.51			0.020		
B	0.77		1.65	0.030		0.065
b		0.5			0.020	
b1		0.25			0.010	
D			20			0.787
E		8.5			0.335	
e		2.54			0.100	
e3		17.78			0.700	
F			7.1			0.280
I			5.1			0.201
L		3.3			0.130	
Z			1.27			0.050

### OUTLINE AND MECHANICAL DATA



**DIP16**

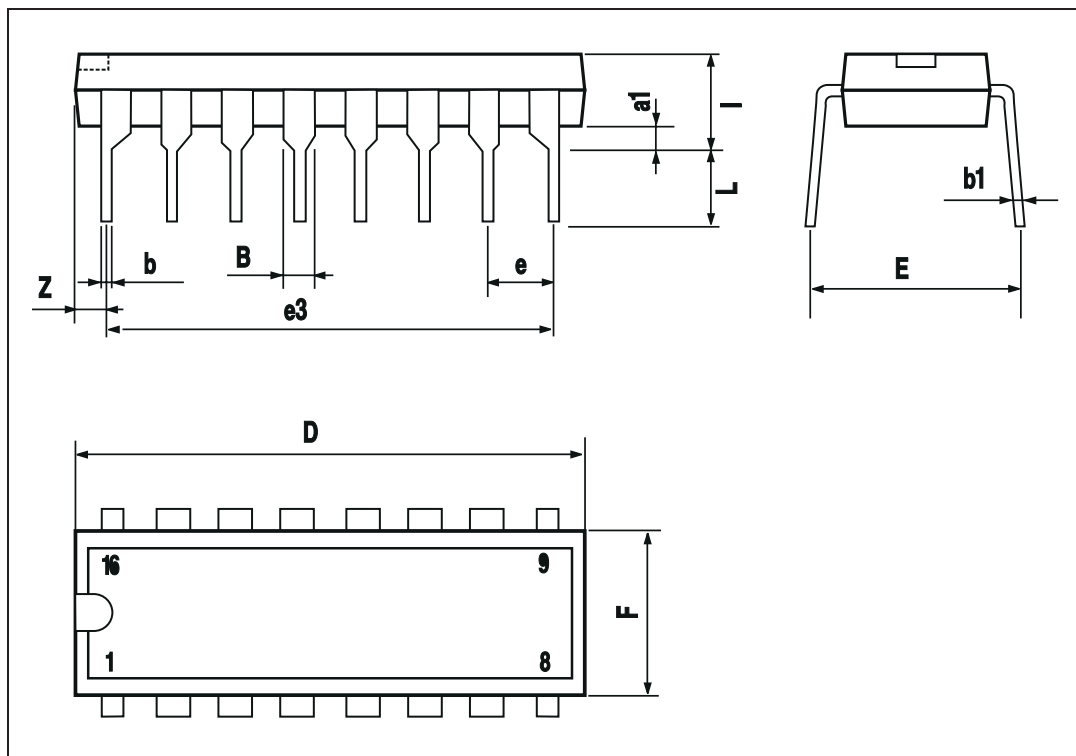

## 6 REVISION HISTORY

**Table 7. Revision History**

<b>Date</b>	<b>Revision</b>	<b>Description of Changes</b>
September 2003	2	Updates not recorded
30-Apr-2010	3	Updated title and added environmental compliance statement for package

**Please Read Carefully:**

Information in this document is provided solely in connection with ST products. STMicroelectronics NV and its subsidiaries ("ST") reserve the right to make changes, corrections, modifications or improvements, to this document, and the products and services described herein at any time, without notice.

All ST products are sold pursuant to ST's terms and conditions of sale.

Purchasers are solely responsible for the choice, selection and use of the ST products and services described herein, and ST assumes no liability whatsoever relating to the choice, selection or use of the ST products and services described herein.

No license, express or implied, by estoppel or otherwise, to any intellectual property rights is granted under this document. If any part of this document refers to any third party products or services it shall not be deemed a license grant by ST for the use of such third party products or services, or any intellectual property contained therein or considered as a warranty covering the use in any manner whatsoever of such third party products or services or any intellectual property contained therein.

**UNLESS OTHERWISE SET FORTH IN ST'S TERMS AND CONDITIONS OF SALE ST DISCLAIMS ANY EXPRESS OR IMPLIED WARRANTY WITH RESPECT TO THE USE AND/OR SALE OF ST PRODUCTS INCLUDING WITHOUT LIMITATION IMPLIED WARRANTIES OF MERCHANTABILITY, FITNESS FOR A PARTICULAR PURPOSE (AND THEIR EQUIVALENTS UNDER THE LAWS OF ANY JURISDICTION), OR INFRINGEMENT OF ANY PATENT, COPYRIGHT OR OTHER INTELLECTUAL PROPERTY RIGHT.**

**UNLESS EXPRESSLY APPROVED IN WRITING BY AN AUTHORIZED ST REPRESENTATIVE, ST PRODUCTS ARE NOT RECOMMENDED, AUTHORIZED OR WARRANTED FOR USE IN MILITARY, AIR CRAFT, SPACE, LIFE SAVING, OR LIFE SUSTAINING APPLICATIONS, NOR IN PRODUCTS OR SYSTEMS WHERE FAILURE OR MALFUNCTION MAY RESULT IN PERSONAL INJURY, DEATH, OR SEVERE PROPERTY OR ENVIRONMENTAL DAMAGE. ST PRODUCTS WHICH ARE NOT SPECIFIED AS "AUTOMOTIVE GRADE" MAY ONLY BE USED IN AUTOMOTIVE APPLICATIONS AT USER'S OWN RISK.**

Resale of ST products with provisions different from the statements and/or technical features set forth in this document shall immediately void any warranty granted by ST for the ST product or service described herein and shall not create or extend in any manner whatsoever, any liability of ST.

ST and the ST logo are trademarks or registered trademarks of ST in various countries.

Information in this document supersedes and replaces all information previously supplied.

The ST logo is a registered trademark of STMicroelectronics. All other names are the property of their respective owners.

© 2010 STMicroelectronics - All rights reserved

STMicroelectronics group of companies

Australia - Belgium - Brazil - Canada - China - Czech Republic - Finland - France - Germany - Hong Kong - India - Israel - Italy - Japan - Malaysia - Malta - Morocco - Philippines - Singapore - Spain - Sweden - Switzerland - United Kingdom - United States of America

[www.st.com](http://www.st.com)

## Looking for pricing, stock, or lifecycle information?

Click below to explore more details on WIN SOURCE:

- ⊖ [View TEA2025B](#) on WIN SOURCE
- ⊖ [STMicroelectronics](#) Information

## Optimize Your Supply Chain with WIN SOURCE Solutions

- ✓ Global Sourcing Solution
- ✓ Obsolete Management
- ✓ Cost Control Management
- ✓ Shortage Management
- ✓ Alternative Solution
- ✓ Excess Inventory Management