



THE DATASHEET OF
8302AMLF



GENERAL DESCRIPTION

The 8302 is a low skew, 1-to-2 LVCMOS/LVTTTL Fanout Buffer. The 8302 has a single ended clock input. The single ended clock input accepts LVCMOS or LVTTTL input levels. The 8302 features a pair of LVCMOS/LVTTTL outputs. The 8302 is characterized at full 3.3V for input V_{DD} , and mixed 3.3V and 2.5V for output operating supply modes (V_{DDO}). Guaranteed output and part-to-part skew characteristics make the 8302 ideal for clock distribution applications demanding well defined performance and repeatability.

FEATURES

- 2 LVCMOS / LVTTTL outputs
- LVCMOS / LVTTTL clock input accepts LVCMOS or LVTTTL input levels
- Maximum output frequency: 200MHz
- Output skew: 25ps (typical)
- Part-to-part skew: 250ps (typical)
- Small 8 lead SOIC package saves board space
- Full 3.3V or 3.3V core, 2.5V supply modes
- 0°C to 70°C ambient operating temperature
- Lead-Free package fully RoHS compliant

BLOCK DIAGRAM

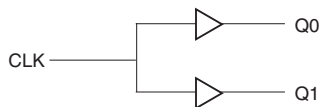

PIN ASSIGNMENT

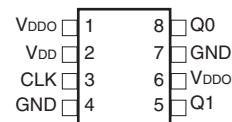

8302
8-Lead SOIC
 3.8mm x 4.8mm, x 1.47mm package body
M Package
 Top View

TABLE 1. PIN DESCRIPTIONS

Number	Name	Type		Description
1, 6	V _{DDO}	Power		Output supply pins.
2	V _{DD}	Power		Core supply pin.
3	CLK	Input	Pulldown	LVC MOS / LVTTTL clock input.
4,7	GND	Power		Power supply ground.
5	Q1	Output		Single clock output. LVC MOS / LVTTTL interface levels.
8	Q0	Output		Single clock output. LVC MOS / LVTTTL interface levels.

NOTE: *Pullup* and *Pulldown* refer to internal input resistors. See Table 2, Pin Characteristics, for typical values.

TABLE 2. PIN CHARACTERISTICS

Symbol	Parameter	Test Conditions	Minimum	Typical	Maximum	Units
C _{IN}	Input Capacitance			4		pF
C _{PD}	Power Dissipation Capacitance (per output)	V _{DD} , V _{DDO} = 3.465V		22		pF
		V _{DD} = 3.465V, V _{DDO} = 2.625V		16		pF
R _{PULLDOWN}	Input Pulldown Resistor			51		kΩ
R _{OUT}	Output Impedance		5	7	12	Ω

ABSOLUTE MAXIMUM RATINGS

Supply Voltage, V_{DD}	4.6V
Inputs, V_I	-0.5V to $V_{DD} + 0.5V$
Outputs, V_O	-0.5V to $V_{DDO} + 0.5V$
Package Thermal Impedance, θ_{JA}	112.7°C/W (0 lfpm)
Storage Temperature, T_{STG}	-65°C to 150°C

NOTE: Stresses beyond those listed under Absolute Maximum Ratings may cause permanent damage to the device. These ratings are stress specifications only. Functional operation of product at these conditions or any conditions beyond those listed in the *DC Characteristics* or *AC Characteristics* is not implied. Exposure to absolute maximum rating conditions for extended periods may affect product reliability.

TABLE 3A. POWER SUPPLY DC CHARACTERISTICS, $V_{DD} = V_{DDO} = 3.3V \pm 5\%$, $T_A = 0^\circ\text{C}$ TO 70°C

Symbol	Parameter	Test Conditions	Minimum	Typical	Maximum	Units
V_{DD}	Core Supply Voltage		3.135	3.3	3.465	V
V_{DDO}	Output Power Supply Voltage		3.135	3.3	3.465	V
I_{DD}	Power Supply Current				13	mA
I_{DDO}	Output Supply Current				4	mA

TABLE 3B. LVCMOS / LVTTTL DC CHARACTERISTICS, $V_{DD} = V_{DDO} = 3.3V \pm 5\%$, $T_A = 0^\circ\text{C}$ TO 70°C

Symbol	Parameter	Test Conditions	Minimum	Typical	Maximum	Units
V_{IH}	Input High Voltage		2		$V_{DD} + 0.3$	V
V_{IL}	Input Low Voltage		-0.3		0.8	V
I_{IH}	Input High Current	CLK $V_{DD} = V_{IN} = 3.465V$			150	μA
I_{IL}	Input Low Current	CLK $V_{DD} = 3.465V, V_{IN} = 0V$	-5			μA
V_{OH}	Output High Voltage	50Ω to $V_{DDO}/2$	2.6			V
		$I_{OH} = -100\mu\text{A}$	2.9			V
V_{OL}	Output Low Voltage	50Ω to $V_{DDO}/2$			0.5	V
		$I_{OL} = 100\mu\text{A}$			0.2	V

TABLE 4A. AC CHARACTERISTICS, $V_{DD} = V_{DDO} = 3.3V \pm 5\%$, $T_A = 0^\circ\text{C}$ TO 70°C

Symbol	Parameter	Test Conditions	Minimum	Typical	Maximum	Units
f_{MAX}	Output Frequency				200	MHz
t_{pLH}	Propagation Delay, Low-to-High; NOTE 1	$f \leq 200\text{MHz}$	1.9	2.35	2.8	ns
$t_{sk(o)}$	Output Skew; NOTE 2, 4			25	85	ps
$t_{sk(pp)}$	Part-to-Part Skew; NOTE 3, 4			250	800	ps
t_R	Output Rise Time	20% to 80%	300		800	ps
t_F	Output Fall Time	20% to 80%	300		800	ps
odc	Output Duty Cycle	$f \leq 133\text{MHz}$	45		55	%
		$133\text{MHz} < f \leq 200\text{MHz}$	40		60	%

Parameters measured at f_{MAX} unless otherwise noted.

NOTE 1: Measured from $V_{DD}/2$ of the input to $V_{DDO}/2$ of the output.

NOTE 2: Defined as skew between outputs at the same supply voltage and with equal load conditions. Measured at $V_{DDO}/2$.

NOTE 3: Defined as skew between outputs on different devices operating at the same supply voltages and with equal load conditions. Using the same type of inputs on each device, the outputs are measured at $V_{DDO}/2$.

NOTE 4: This parameter is defined in accordance with JEDEC Standard 65.

TABLE 3C. POWER SUPPLY DC CHARACTERISTICS, $V_{DD} = 3.3V \pm 5\%$, $V_{DDO} = 2.5V \pm 5\%$, $T_A = 0^\circ C$ TO $70^\circ C$

Symbol	Parameter	Test Conditions	Minimum	Typical	Maximum	Units
V_{DD}	Core Supply Voltage		3.135	3.3	3.465	V
V_{DDO}	Output Supply Voltage		2.375	2.5	2.625	V
I_{DD}	Power Supply Current				13	mA
I_{DDO}	Output Supply Current				4	mA

TABLE 3D. LVCMOS / LVTTTL DC CHARACTERISTICS, $V_{DD} = 3.3V \pm 5\%$, $V_{DDO} = 2.5V \pm 5\%$, $T_A = 0^\circ C$ TO $70^\circ C$

Symbol	Parameter	Test Conditions	Minimum	Typical	Maximum	Units
V_{IH}	Input High Voltage		2		$V_{DD} + 0.3$	V
V_{IL}	Input Low Voltage		-0.3		0.8	V
I_{IH}	Input High Current	CLK $V_{DD} = V_{IN} = 3.465V$			150	μA
I_{IL}	Input Low Current	CLK $V_{DD} = 3.465V, V_{IN} = 0V$	-5			μA
V_{OH}	Output High Voltage	50Ω to $V_{DDO}/2$	1.8			V
		$I_{OH} = -100\mu A$	2.2			V
V_{OL}	Output Low Voltage	50Ω to $V_{DDO}/2$			0.5	V
		$I_{OL} = 100\mu A$			0.2	V

TABLE 4B. AC CHARACTERISTICS, $V_{DD} = 3.3V \pm 5\%$, $V_{DDO} = 2.5V \pm 5\%$, $T_A = 0^\circ C$ TO $70^\circ C$

Symbol	Parameter	Test Conditions	Minimum	Typical	Maximum	Units
f_{MAX}	Output Frequency				200	MHz
t_{pLH}	Propagation Delay, Low-to-High; NOTE 1	$f \leq 200MHz$	2.3		3.3	ns
$tsk(o)$	Output Skew; NOTE 2, 4				85	ps
$tsk(pp)$	Part-to-Part Skew; NOTE 3, 4			250	800	ps
t_R	Output Rise Time	20% to 80%	250		650	ps
t_F	Output Fall Time	20% to 80%	250		650	ps
odc	Output Duty Cycle	$f \leq 133MHz$	45		55	%
		$133MHz < f \leq 200MHz$	40		60	%

Parameters measured at f_{MAX} unless otherwise noted.

NOTE 1: Measured from $V_{DD}/2$ of the input to $V_{DDO}/2$ of the output.

NOTE 2: Defined as skew between outputs at the same supply voltage and with equal load conditions.

Measured at $V_{DDO}/2$.

NOTE 3: Defined as skew between outputs on different devices operating at the same supply voltages and with equal load conditions. Using the same type of inputs on each device, the outputs are measured at $V_{DDO}/2$.

NOTE 4: This parameter is defined in accordance with JEDEC Standard 65.

PARAMETER MEASUREMENT INFORMATION

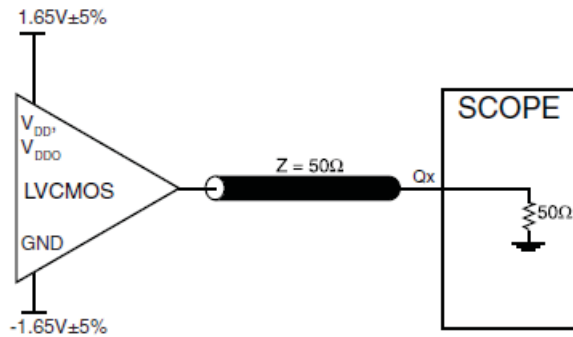
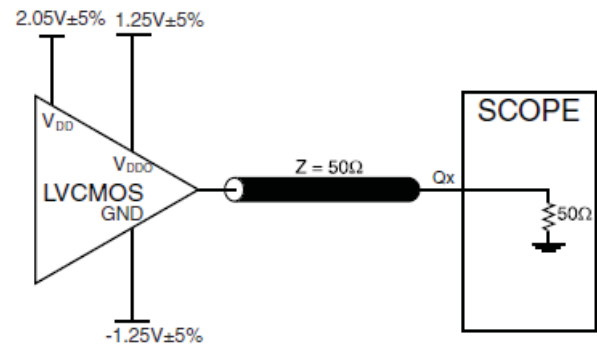
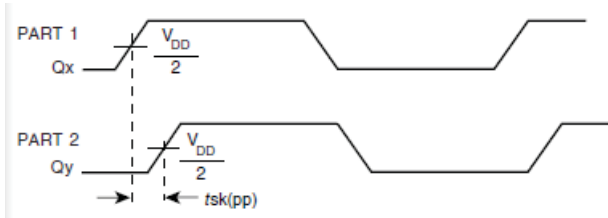
3.3V OUTPUT LOAD AC TEST CIRCUIT

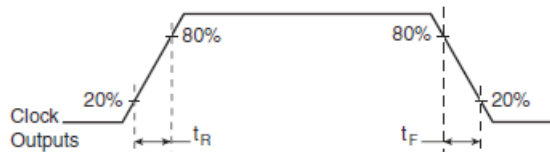
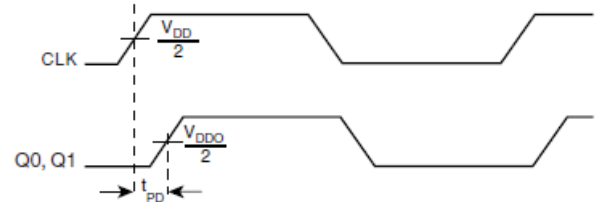
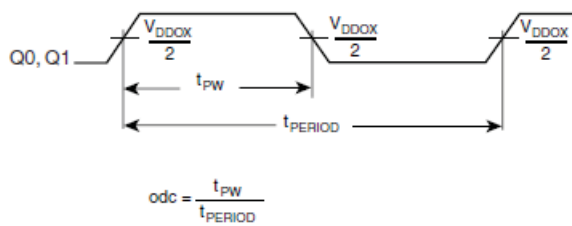
3.3V/2.5V OUTPUT LOAD AC TEST CIRCUIT

PART-TO-PART SKEW

OUTPUT SKEW

OUTPUT RISE/FALL TIME

PROPAGATION DELAY

OUTPUT PULSE WIDTH/PERIOD

RELIABILITY INFORMATION

TABLE 5. θ_{JA} VS. AIR FLOW TABLE FOR 8 LEAD SOIC

θ_{JA} by Velocity (Linear Feet per Minute)			
	0	200	500
Single-Layer PCB, JEDEC Standard Test Boards	153.3°C/W	128.5°C/W	115.5°C/W
Multi-Layer PCB, JEDEC Standard Test Boards	112.7°C/W	103.3°C/W	97.1°C/W

NOTE: Most modern PCB designs use multi-layered boards. The data in the second row pertains to most designs.

TRANSISTOR COUNT

The transistor count for 8302 is: 322

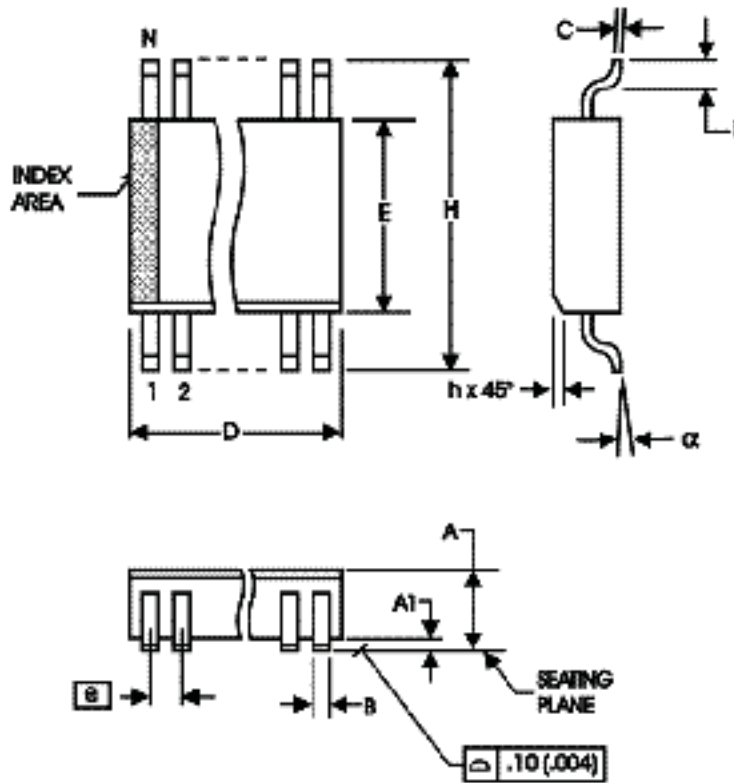
PACKAGE OUTLINE - SUFFIX M FOR 8 LEAD SOIC

TABLE 6. PACKAGE DIMENSIONS

SYMBOL	Millimeters	
	MINIMUM	MAXIMUM
N	8	
A	1.35	1.75
A1	0.10	0.25
B	0.33	0.51
C	0.19	0.25
D	4.80	5.00
E	3.80	4.00
e	1.27 BASIC	
H	5.80	6.20
h	0.25	0.50
L	0.40	1.27
α	0°	8°

Reference Document: JEDEC Publication 95, MS-012

TABLE 7. ORDERING INFORMATION

Part/Order Number	Marking	Package	Shipping Packaging	Temperature
8302AMLF	8302AMLF	8 lead "Lead Free" SOIC	tube	0°C to 70°C
8302AMLFT	8302AMLF	8 lead "Lead Free" SOIC	tape & reel	0°C to 70°C

REVISION HISTORY SHEET				
Rev	Table	Page	Description of Change	Date
B	T1	2	Pin Description table, revised V_{DD} description.	2/4/03
	T2	2	Pin Characteristics table, deleted R_{PULLUP} row.	
	T3A & T3C	3, 4	Power Supply table, changed V_{DD} parameter to correspond with description.	
	T4A & T4B	3, 4	AC Characteristics tables - added note "Parameters measured at f_{MAX} unless otherwise noted." $t_{p_{LH}}$ Test Conditions, added $f \leq 200\text{MHz}$.	
C	T2	2	Pin Characteristics table - changed C_{IN} 4pF max. to 4pF typical. Added 5 Ω min. and 12 Ω max. to R_{OUT} row.	6/15/04
	T7	8	Ordering Information table - added "Lead-Free" part number.	
D	T3B & T3D	3, 4	LVC MOS DC Characteristics Table - changed V_{IL} max. from 1.3V to 0.8V.	5/17/05
	T7	8	Ordering Information Table - added Lead-Free note.	
D	T7	8	Updated datasheet's header/footer with IDT from ICS.	7/30/10
		10	Removed ICS prefix from Part/Order Number column. Added Contact Page.	
D	T7	8	Ordering Information - removed leaded devices. Updated data sheet format.	11/19/15
D			Updated header and footer.	3/4/16



Corporate Headquarters
6024 Silver Creek Valley Road
San Jose, CA 95138 USA
www.IDT.com

Sales
1-800-345-7015 or 408-284-8200
Fax: 408-284-2775
www.IDT.com/go/sales

Tech Support
www.idt.com/go/support

DISCLAIMER Integrated Device Technology, Inc. (IDT) reserves the right to modify the products and/or specifications described herein at any time, without notice, at IDT's sole discretion. Performance specifications and operating parameters of the described products are determined in an independent state and are not guaranteed to perform the same way when installed in customer products. The information contained herein is provided without representation or warranty of any kind, whether express or implied, including, but not limited to, the suitability of IDT's products for any particular purpose, an implied warranty of merchantability, or non-infringement of the intellectual property rights of others. This document is presented only as a guide and does not convey any license under intellectual property rights of IDT or any third parties.

IDT's products are not intended for use in applications involving extreme environmental conditions or in life support systems or similar devices where the failure or malfunction of an IDT product can be reasonably expected to significantly affect the health or safety of users. Anyone using an IDT product in such a manner does so at their own risk, absent an express, written agreement by IDT.

Integrated Device Technology, IDT and the IDT logo are trademarks or registered trademarks of IDT and its subsidiaries in the United States and other countries. Other trademarks used herein are the property of IDT or their respective third party owners.

For datasheet type definitions and a glossary of common terms, visit www.idt.com/go/glossary.

Copyright ©2016 Integrated Device Technology, Inc. All rights reserved.

Looking for pricing, stock, or lifecycle information?

Click below to explore more details on WIN SOURCE:

- ⊖ [View 8302AMLF on WIN SOURCE](#)
- ⊖ [IDT, Integrated Device Technology Inc Information](#)

Optimize Your Supply Chain with WIN SOURCE Solutions

- ✓ Global Sourcing Solution
- ✓ Obsolete Management
- ✓ Cost Control Management
- ✓ Shortage Management
- ✓ Alternative Solution
- ✓ Excess Inventory Management