



THE DATASHEET OF TDA8145





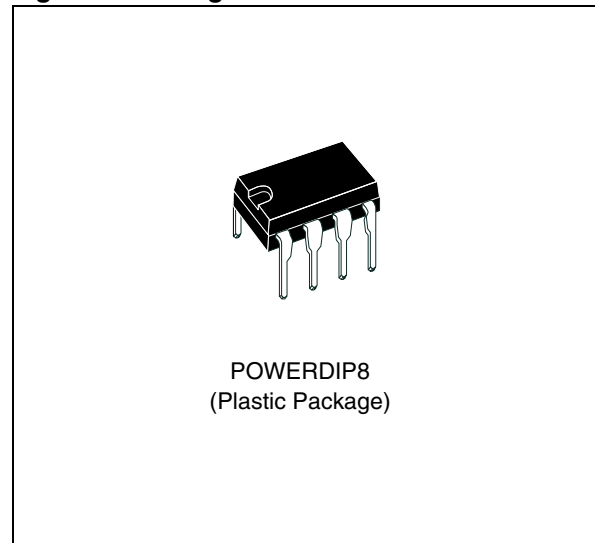
TDA8145

TV EAST/WEST CORRECTION CIRCUIT FOR SQUARE TUBES

FEATURES SUMMARY

- LOW DISSIPATION
- SQUARE GENERATOR FOR PARABOLIC CURRENT SPECIALLY DESIGNED FOR SQUARE C.R.T. CORRECTION
- EXTERNAL KEYSTONE ADJUSTMENT (symmetry of the parabola)
- INPUT FOR DYNAMIC FIELD CORRECTION (beam current change)
- STATIC PICTURE WIDTH ADJUSTMENT
- PULSE-WIDTH MODULATOR
- FINAL STAGE D-CLASS WITH ENERGY REDELIVERY
- PARASITIC PARABOLA SUPPRESSION, DURING FLYBACK TIME OF THE VERTICAL SAWTOOTH

Figure 1. Package



DESCRIPTION

The TDA8145 is a monolithic integrated circuit in a 8 pin minidip plastic package designed for use in the square C.R.T. east-west pin-cushion correction by driving a diode modulator in TV and monitor applications.

Figure 2. Pin Connections (top view)

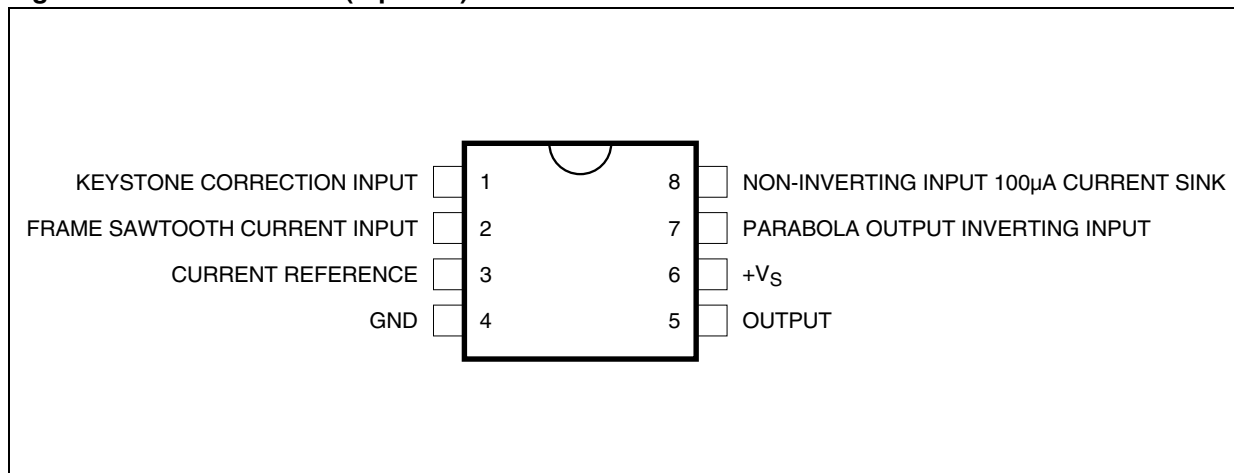


Figure 3. Schematic Diagram

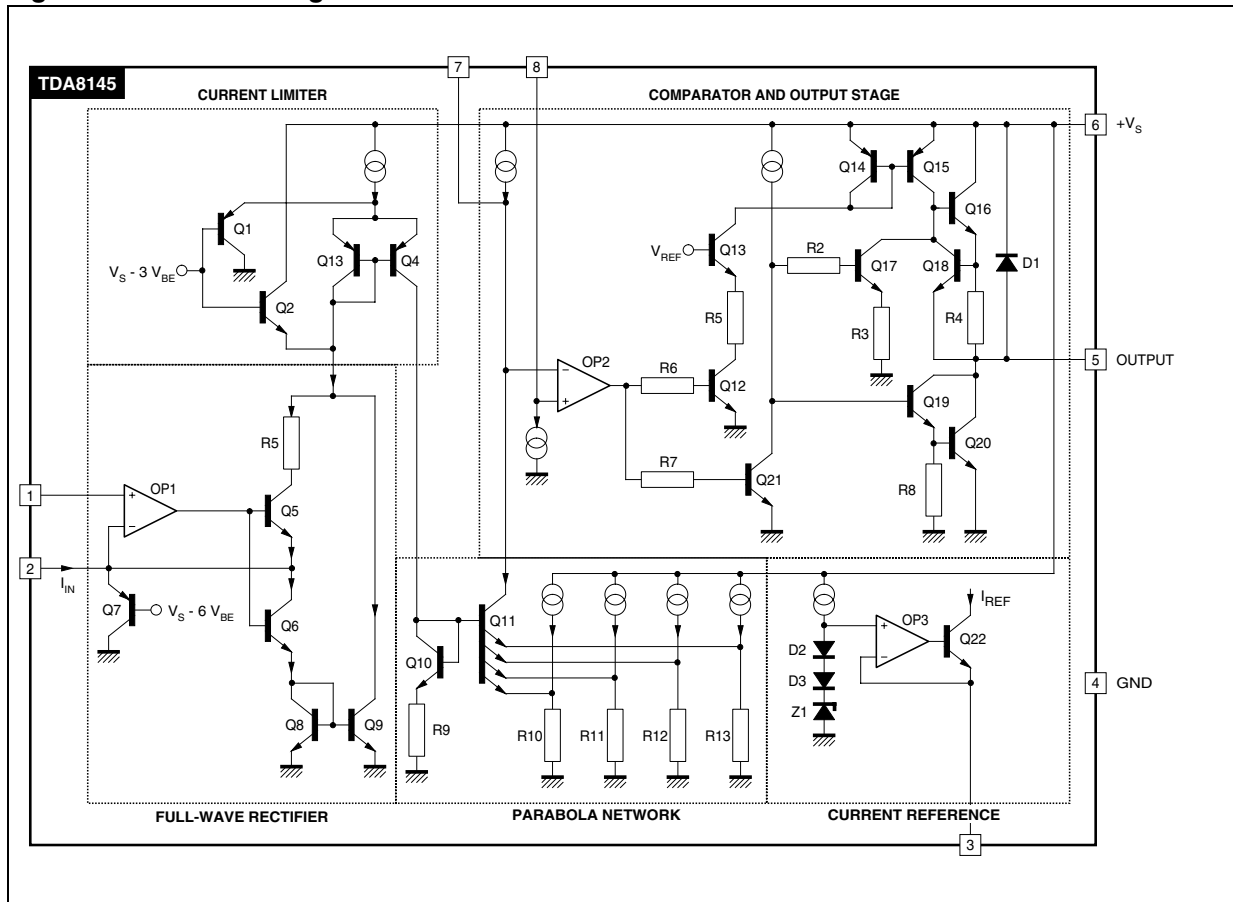


Table 1. Absolute Maximum Ratings

Symbol	Parameter	Value	Unit
V_S	Supply Voltage	35	V
I_S	Supply Current	500	mA
P_{TOT}	Power Dissipation at $T_{amb} = 50^\circ\text{C}$	500	mW
T_{STG}, T_j	Storage and Junction Temperature	- 25 to 150	$^\circ\text{C}$

Table 2. Thermal Data

Symbol	Parameter	Value	Unit
$R_{th(j-c)}$	Thermal Resistance Junction-ambient Max	100	$^\circ\text{C/W}$
$R_{th(j-a)}$	Thermal Resistance Junction-pin 4 Max.	70	$^\circ\text{C/W}$

Table 3. ELECTRICAL CHARACTERISTICS

($T_{amb} = 25^{\circ}\text{C}$, $V_S = 26\text{V}$, $V_{fr} = 0$, S1 and S2 in "a" position, refer to the test circuit unless otherwise specified)

Symbol	Parameter	Test Conditions	Min.	Typ.	Max.	Unit
V_S	Supply Voltage		17	24	30	V
I_S	Supply Current			4.5	7	mA
V_{REF}	Internal Reference Voltage		7.6	8.0	8.8	V
$-I_{REF}$	Internal Reference Current	$V_{ref}/R3$		0.73		mA
$V_{7(A)}^{(*)}$	Pin 7 Output Voltage	$I_{fr} = 0 \mu\text{A}$	15.3	16.0	16.7	V
$V_{7(B)}^{(*)}$	Pin 7 Output Voltage	$I_{fr} = 30 \mu\text{A}$		15		V
K_1	Parabola Coefficient (see Figure 5)	$K_1 = \frac{V_{7A} - V_{7B}}{V_{7A} - V_{7C}}$		0.26		
K_2	Parabola Coefficient (see Figure 5)	$K_2 = \frac{V_{7A} - V_{7C}}{V_{7A} - V_{7D}}$		0.70		
$\Delta V_7^{(*)}$		$\Delta V_7 = V_{7E} - V_{7F}$	-40		40	mV
I_8	Current Source	S1 \rightarrow b		100		μA
V_{SATL}	Saturation Voltage	$I_o = 400 \text{ mA}$ Sink S2 \rightarrow b		1	2	V
V_{SATH}	Saturation Voltage	$I_o = 100 \text{ mA}$ Source S2 \rightarrow c S1 \rightarrow b		0.8	1.5	V
V_F	Forward Voltage	$I_o = 400 \text{ mA}$ S2 \rightarrow d S1 \rightarrow b		1.2	1.7	V
I_{FR}	Frame Sawtooth Current	$V_{fr} = 6.6 V_{PP}$		66		μA

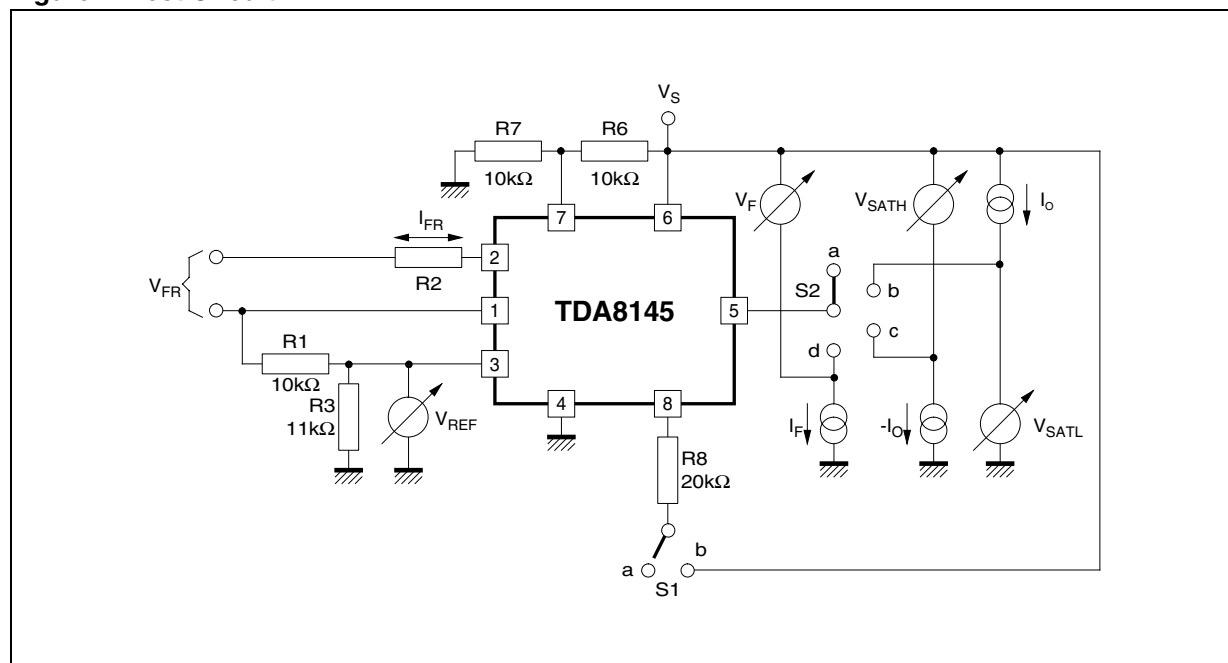
Figure 4. Test Circuit

Figure 5. Parabola Characteristics

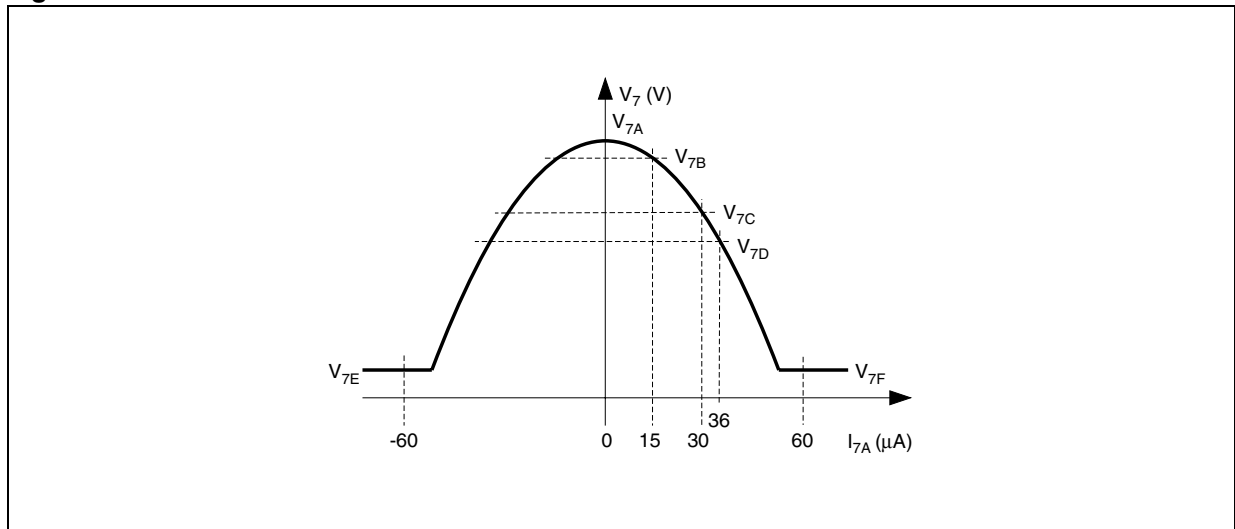
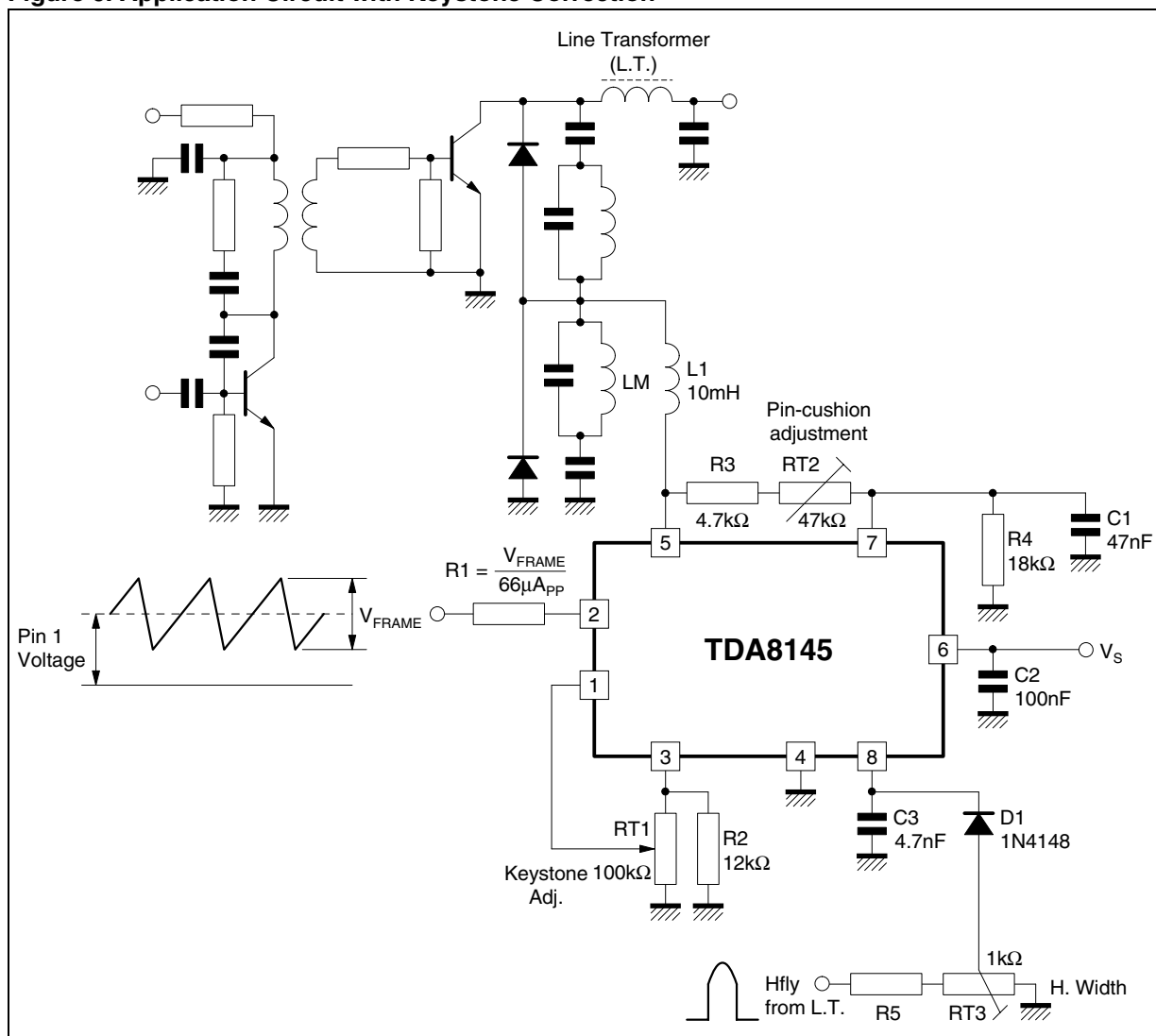


Figure 6. Application Circuit with Keystone Correction



CIRCUIT OPERATION

(see the schematic diagram)

A differential amplifier OP1 is driven by a vertical frequency sawtooth current of $\pm 33\mu A$ which is produced via an external resistor from the sawtooth voltage. The non-inverting input of this amplifier is connected with a reference voltage corresponding to the DC level of the sawtooth voltage. This DC voltage should be adjustable for the keystone correction. The rectified output current of this amplifier drives the parabola network which provides a parabolic output current.

This output current produces the corresponding voltage due to the voltage drop across the external resistor at pin 7.

If the input is overmodulated ($> 40\mu A$) the internal current is limited to $40\mu A$. This limitation can be used for suppressing the parasitic parabolic current generated during the flyback time of the frame sawtooth.

A comparator OP2 is driven by the parabolic current. The second input of the comparator is connected with a horizontal frequency sawtooth voltage the DC level of which can be changed by the external circuitry for the adjustment of the picture width.

The horizontal frequency pulse-width modulated output signal drives the final stage. It consists of a class D push-pull output amplifier that drives, via an external inductor, the diode modulator.

TDA8145

PART NUMBERING

Table 4. Order Codes

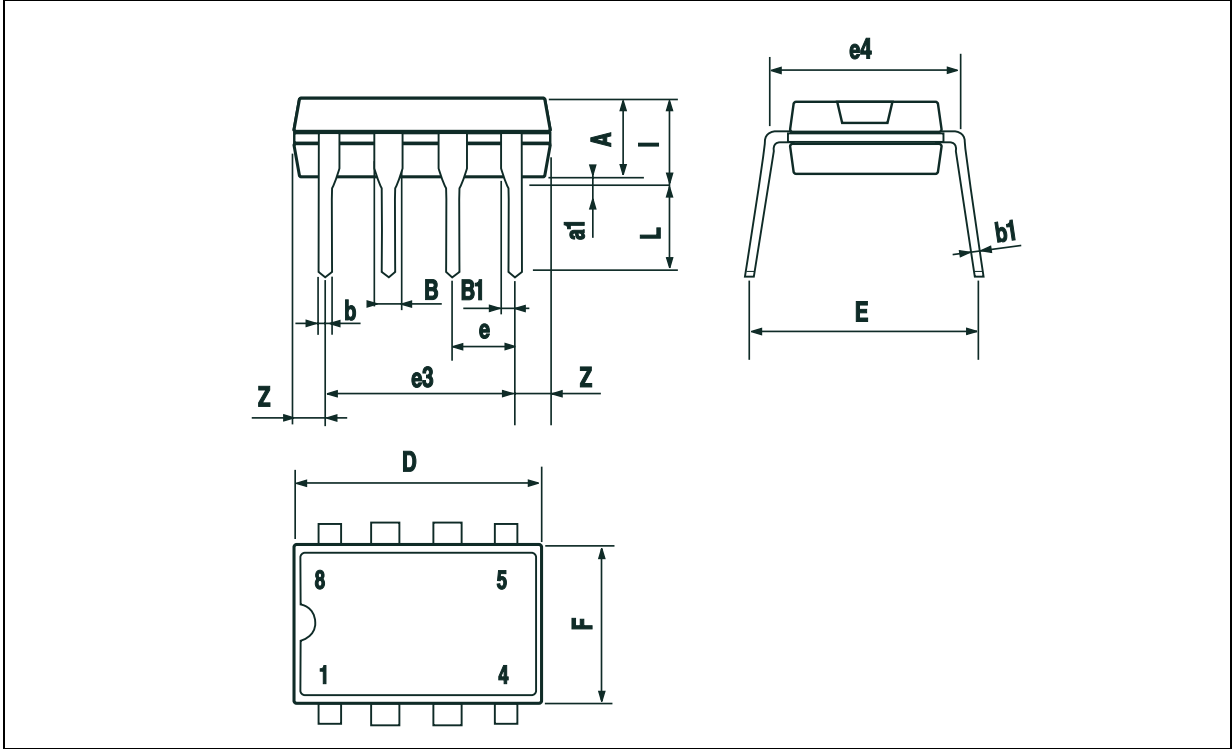
Part Number	Package	Temperature Range
TDA8145	POWERDIP8	0 to 70 °C

PACKAGE MECHANICAL

Table 5. POWERDIP8 - Mechanical Data

Symbol	millimeters			inches		
	Min	Typ	Max	Min	Typ	Max
A		3.3			0.130	
a1	0.7			0.020		
B	1.39		1.65	0.055		0.065
B1	0.91		1.04	0.036		0.041
b		0.5			0.020	
b1	0.38		0.5	0.015		0.020
D			9.8			0.386
E		8.8			0.346	
e		2.54			0.100	
e3		7.62			0.300	
e4		7.62			0.300	
F			7.1			0.280
l			4.8			0.189
L		3.3			0.130	
Z	0.44		1.6	0.017		0.063

Figure 7. POWERDIP8 - Package Dimensions



Note: Drawing is not to scale

REVISION HISTORY

Table 6. Revision History

Date	Revision	Description of Changes
October -1998	1	First Issue
14-May-2004	2	Stylesheet update. No content change.

Information furnished is believed to be accurate and reliable. However, STMicroelectronics assumes no responsibility for the consequences of use of such information nor for any infringement of patents or other rights of third parties which may result from its use. No license is granted by implication or otherwise under any patent or patent rights of STMicroelectronics. Specifications mentioned in this publication are subject to change without notice. This publication supersedes and replaces all information previously supplied. STMicroelectronics products are not authorized for use as critical components in life support devices or systems without express written approval of STMicroelectronics.

The ST logo is a registered trademark of STMicroelectronics.
All other names are the property of their respective owners

© 2004 STMicroelectronics - All rights reserved



STMicroelectronics GROUP OF COMPANIES

Australia - Belgium - Brazil - Canada - China - Czech Republic - Finland - France - Germany - Hong Kong - India - Israel - Italy - Japan -
Malaysia - Malta - Morocco - Singapore - Spain - Sweden - Switzerland - United Kingdom - United States

www.st.com

Looking for pricing, stock, or lifecycle information?

Click below to explore more details on WIN SOURCE:

-  [View TDA8145](#) on WIN SOURCE
-  [STMicroelectronics](#) Information

Optimize Your Supply Chain with WIN SOURCE Solutions

-  Global Sourcing Solution
-  Obsolete Management
-  Cost Control Management
-  Shortage Management
-  Alternative Solution
-  Excess Inventory Management