



THE DATASHEET OF TDA7264



25 +25W STEREO AMPLIFIER WITH MUTE & ST-BY

- WIDE SUPPLY VOLTAGE RANGE (UP TO $\pm 25V$ ABS MAX.)
- SPLIT SUPPLY
- HIGH OUTPUT POWER
25 + 25W @ THD = 10%, $R_L = 8\Omega$, $V_S = \pm 20V$
- NO POP AT TURN-ON/OFF
- MUTE (POP FREE)
- MUTE (POP FREE)
- STAND-BY FEATURE (LOW I_q)
- SHORT CIRCUIT PROTECTION
- THERMAL OVERLOAD PROTECTION

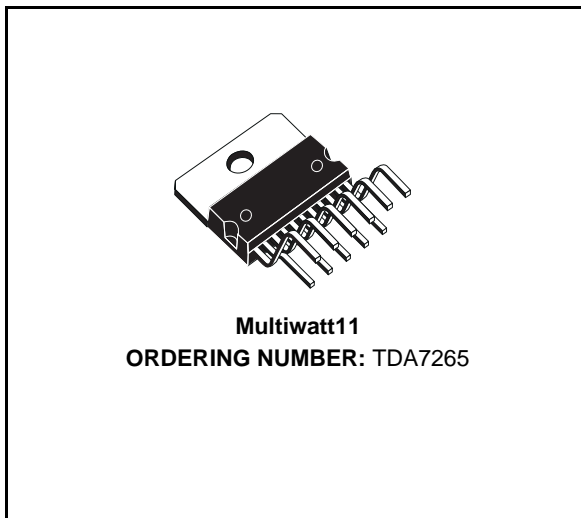

DESCRIPTION

The TDA7265 is class AB dual Audio power amplifier assembled in the Multiwatt package, specially designed for high quality sound application as Hi-Fi music centers and stereo TV sets.

Figure 1: Typical Application Circuit in Split Supply

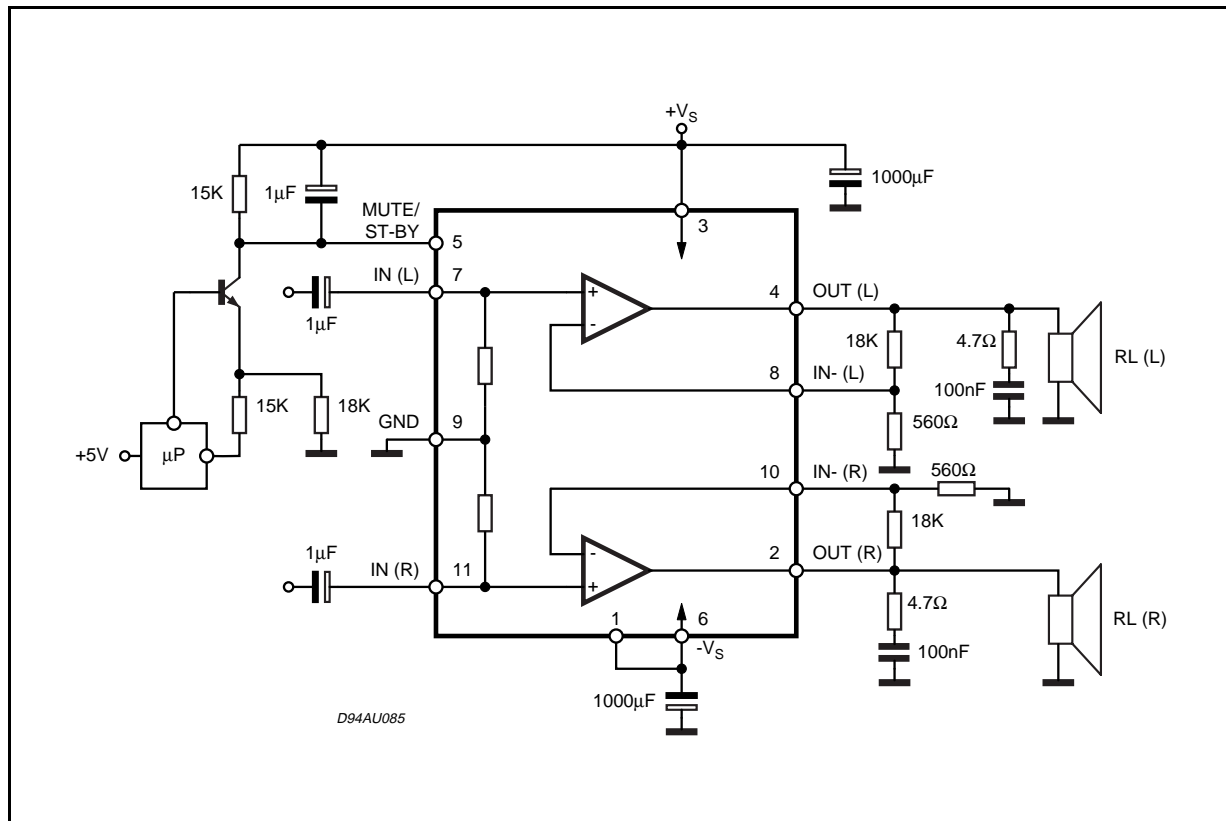

ABSOLUTE MAXIMUM RATINGS

Symbol	Parameter	Value	Unit
V_S	DC Supply Voltage	± 25	V
I_O	Output Peak Current (internally limited)	4.5	A
P_{tot}	Power Dissipation $T_{case} = 70^\circ\text{C}$	30	W
T_{op}	Operating Temperature	-20 to 85	$^\circ\text{C}$
T_{stg}, T_j	Storage and Junction Temperature	-40 to +150	$^\circ\text{C}$

PIN CONNECTION (Top view)

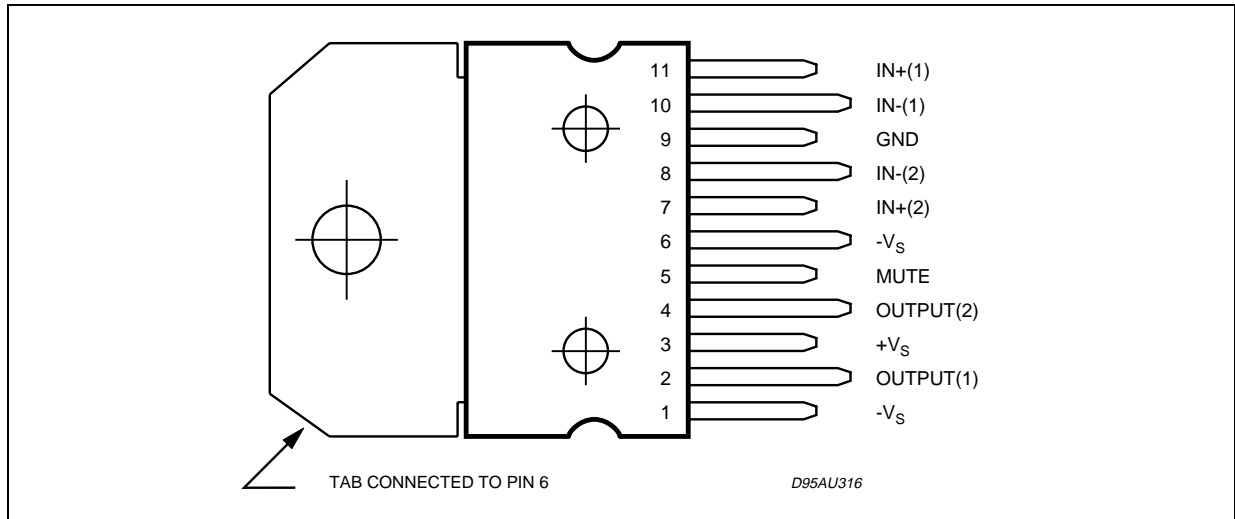

THERMAL DATA

Symbol	Description	Value	Unit
$R_{th\ j-case}$	Thermal Resistance Junction-case	Max 2	$^\circ\text{C/W}$

Fig 2: Typical Application Circuit in Single Supply

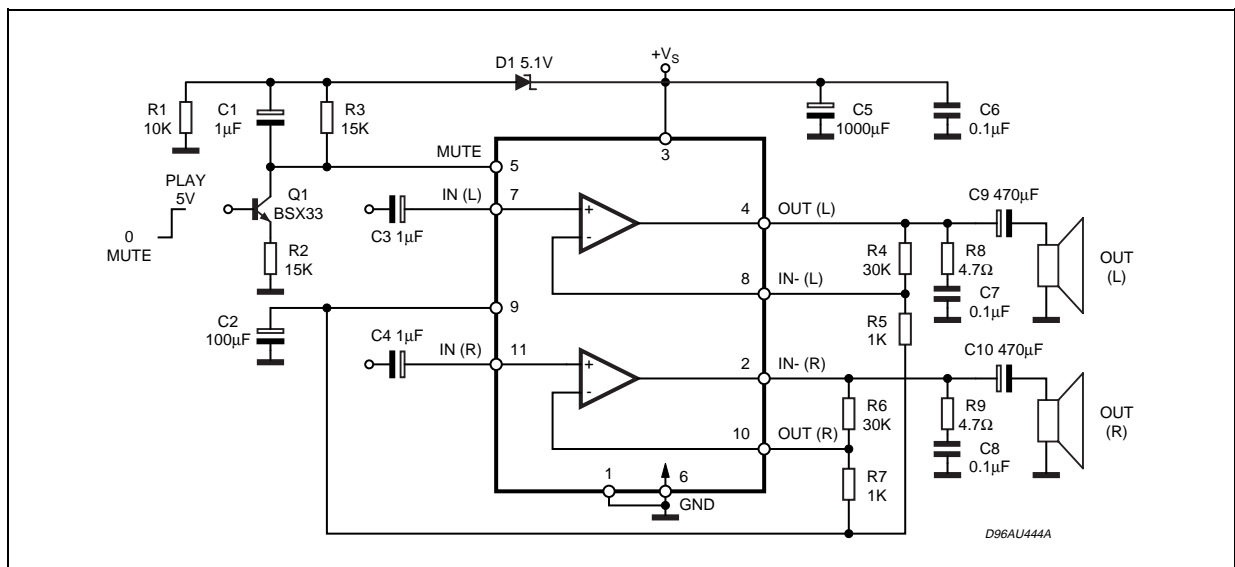

ELECTRICAL CHARACTERISTICS (Refer to the test circuit, $V_S = \pm 20V$; $R_L = 8\Omega$; $R_S = 50\Omega$; $G_V = 30dB$; $f = 1KHz$; $T_{amb} = 25^\circ C$, unless otherwise specified.)

Symbol	Parameter	Test Condition	Min.	Typ.	Max.	Unit
V_S	Supply Range		± 5		± 25	V
I_q	Total Quiescent Current			80	130	mA
V_{OS}	Input Offset Voltage		-20		+20	mV
I_b	Non Inverting Input Bias Current			500		nA
P_O	Music Output Power (*)	THD = 10%; $R_L = 8\Omega$; $V_S = \pm 22.5V$		32		W
P_O	Output Power	THD = 10% $R_L = 8\Omega$; $V_S \pm 16V$; $R_L = 4\Omega$	20	25 25		W W
		THD = 1% $R_L = 8\Omega$; $V_S \pm 16V$; $R_L = 4\Omega$		20 20		W W
THD	Total Harmonic Distortion	$R_L = 8\Omega$; $P_O = 1W$; $f = 1KHz$		0.01		%
		$R_L = 8\Omega$; $P_O = 0.1$ to $15W$; $f = 100Hz$ to $15KHz$			0.7	%
		$R_L = 4\Omega$; $P_O = 1W$; $f = 1KHz$		0.02		%
		$R_L = 4\Omega$; $V_S \pm 16V$; $P_O = 0.1$ to $12W$; $f = 100Hz$ to $15KHz$			1	%
C_T	Cross Talk	$f = 1KHz$		70		dB
		$f = 10KHz$		60		dB
SR	Slew Rate			10		V/ μs
G_{OL}	Open Loop Voltage Gain			80		dB
e_N	Total Input Noise	A Curve $f = 20Hz$ to $22KHz$		3		μV
				4	8	μV
R_i	Input Resistance		15	20		K Ω
SVR	Supply Voltage Rejection (each channel)	$f_r = 100Hz$ $V_r = 0.5V$		60		dB
T_j	Thermal Shut-down Junction Temperature			145		$^\circ C$
MUTE FUNCTION [ref: +Vs]						
V_{T_MUTE}	Mute / Play Threshold		-7	-6	-5	V
A_M	Mute Attenuation		60	70		dB
STAND-BY FUNCTION [ref: +Vs]						
V_{T_ST-BY}	Stand-by / Mute Threshold		-3.5	-2.5	-1.5	V
A_{ST-BY}	Stand-by Attenuation			110		dB
I_{q_ST-BY}	Quiescent Current @ Stand-by			3		mA

Note :

(*) FULL POWER up to. $V_S = \pm 22.5V$ with $R_L = 8\Omega$ and $V_S = \pm 16V$ with $R_L = 4\Omega$

MUSIC POWER is the maximal power which the amplifier is capable of producing across the rated load resistance (regardless of non linearity) 1 sec after the application of a sinusoidal input signal of frequency 1KHz.

Figure 3: Quiescent Current vs. Supply Voltage

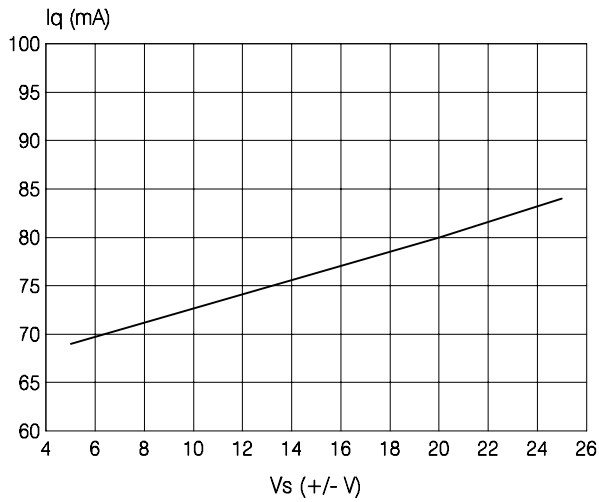

Figure 4: Frequency Response

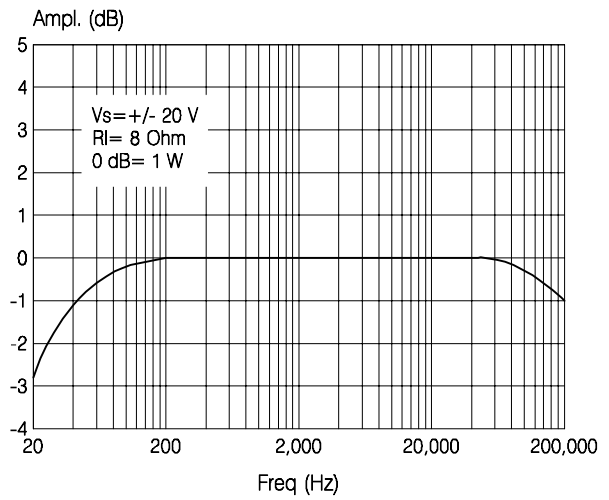

Figure 5: Output Power vs. Supply Voltage

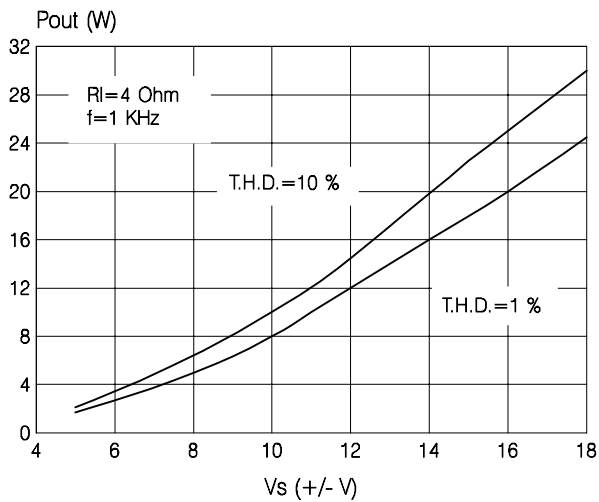

Figure 6: T.H.D. vs. Output Power

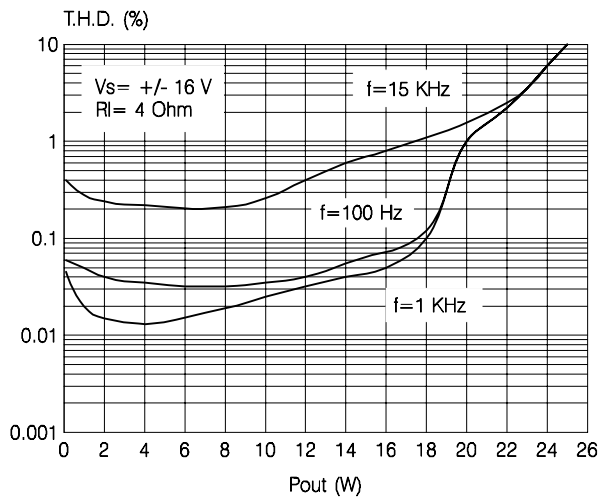

Figure 7: Output Power vs. Supply Voltage

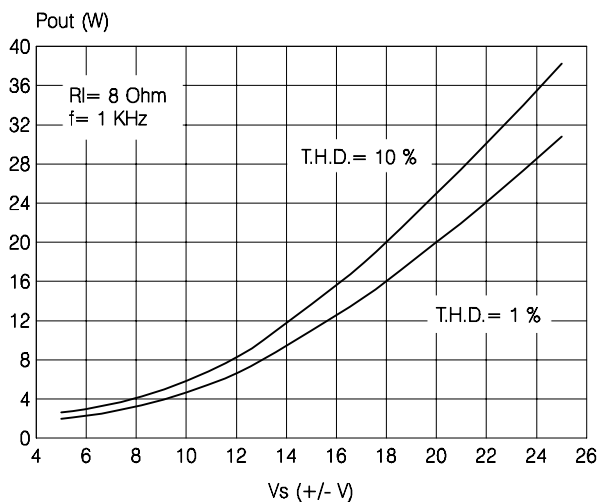

Figure 8: T.H.D. vs. Output Power

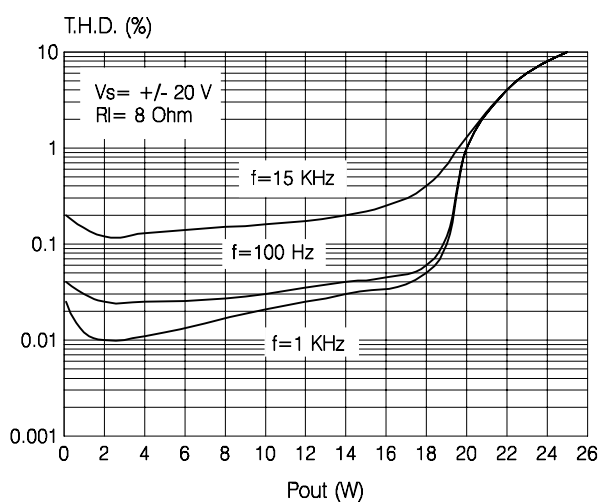

Figure 9: Quiescent Current vs. Pin # 5 Voltage

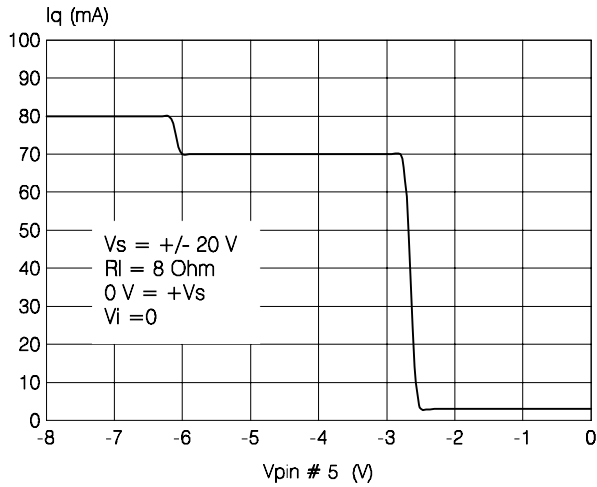

Figure 10: Attenuation vs. Pin # 5 Voltage

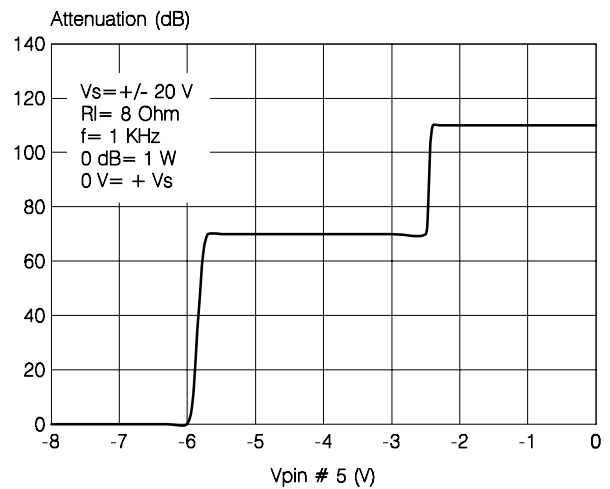

Figure 11: SVR vs. Frequency

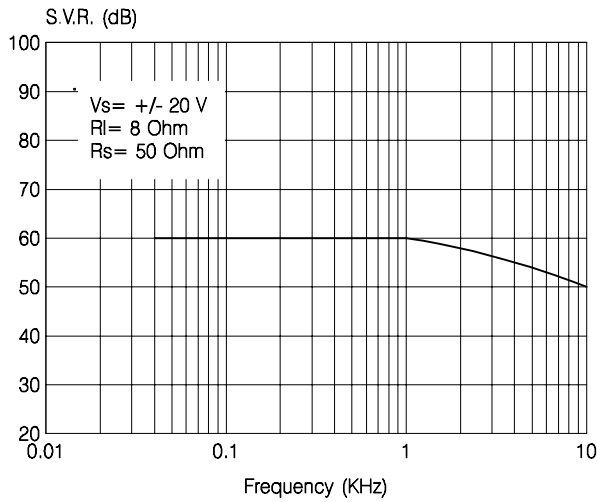

Figure 12: Crosstalk vs. Frequency

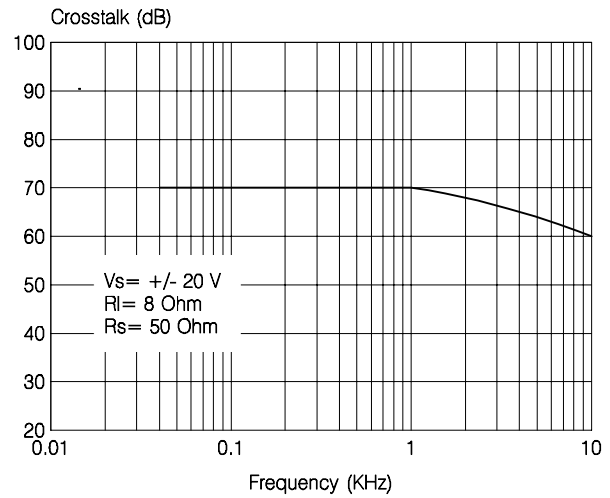

Figure 13: Power Dissipation vs. Output Power

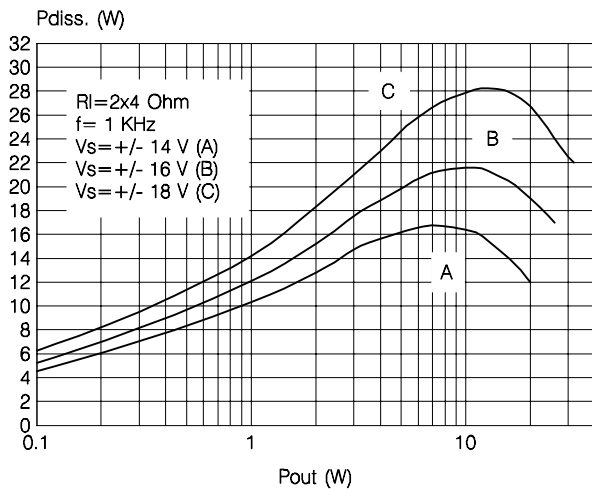
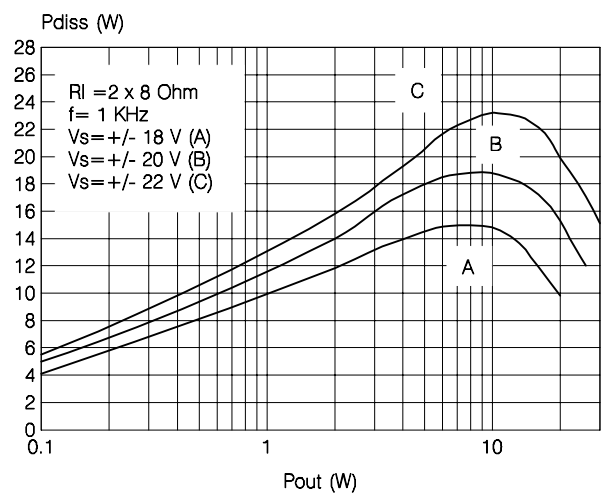

Figure 14: Power Dissipation vs. Output Power



MUTE STAND-BY FUNCTION

The pin 5 (MUTE/STAND-BY) controls the amplifier status by two different thresholds, referred to +Vs.

- When V_{pin5} higher than $+Vs - 2.5V$ the amplifier is in Stand-by mode and the final stage generators are off

- when V_{pin5} is between $+Vs - 2.5V$ and $+Vs - 6V$ the final stage current generators are switched on and the amplifier is in mute mode
- when V_{pin5} is lower than $+Vs - 6V$ the amplifier is play mode.

Figure 15

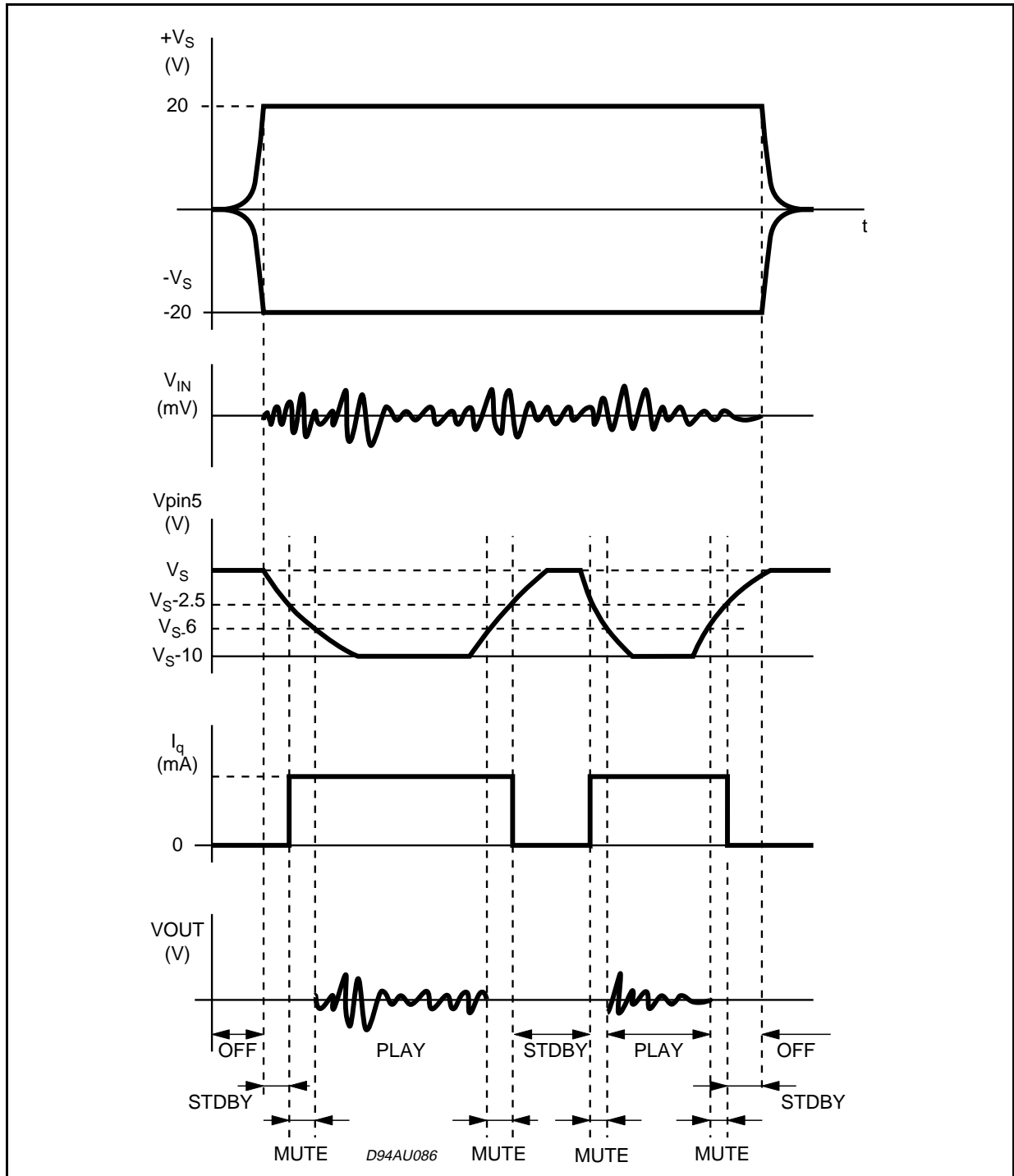

Figure 16: Test and Application Circuit (Stereo Configuration)

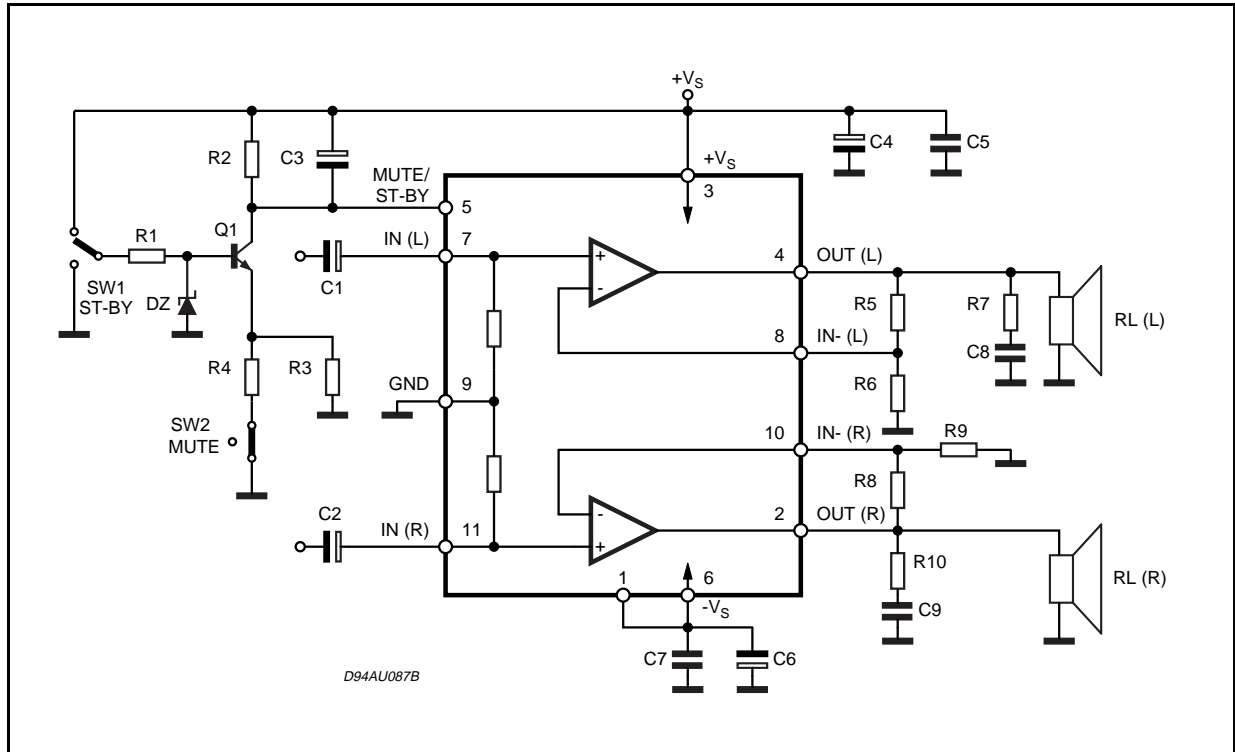
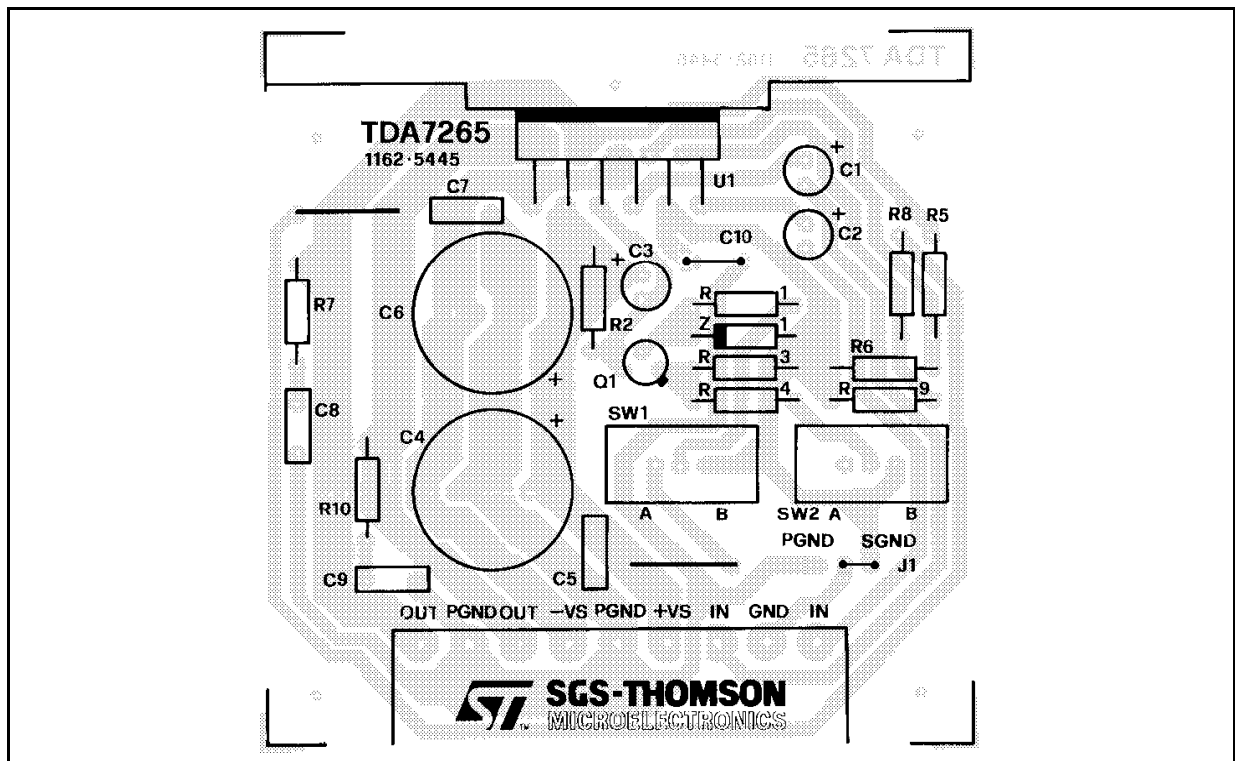

Figure 17: PC Board and Components Layout of the figure 15 (1:1 scale)



APPLICATIONS SUGGESTION

(Demo Board Schematic)

The recommended values of the external compo-

nents are those shown are the demo board schematic different values can be used: the following table can help the designer.

COMPONENTS	RECOMMENDED VALUE	PURPOSE	LARGER THAN RECOMMENDED VALUE	SMALLER THAN RECOMMENDED VALUE
R1	10KΩ	Mute Circuit	Increase of Dz Biasing Current	
R2	15KΩ	Mute Circuit	V _{pin # 5} Shifted Downward	V _{pin # 5} Shifted Upward
R3	18KΩ	Mute Circuit	V _{pin # 5} Shifted Upward	V _{pin # 5} Shifted Downward
R4	15KΩ	Mute Circuit	V _{pin # 5} Shifted Upward	V _{pin # 5} Shifted Downward
R5, R8	18KΩ	Closed Loop Gain Setting (*)	Increase of Gain	
R6, R9	560Ω		Decrease of Gain	
R7, R10	4.7Ω	Frequency Stability	Danger of Oscillations	Danger of Oscillations
C1, C2	1μF	Input DC Decoupling		Higher Low Frequency Cutoff
C3	1μF	St-By/Mute Time Constant	Larger On/Off Time	Smaller On/Off Time
C4, C6	1000μF	Supply Voltage Bypass		Danger of Oscillations
C5, C7	0.1μF	Supply Voltage Bypass		Danger of Oscillations
C8, C9	0.1μF	Frequency Stability		
Dz	5.1V	Mute Circuit		
Q1	BC107	Mute Circuit		

(*) Closed loop gain has to be => 25dB

MUTE, STAND-BY TRUTH TABLE

SW1	SW2	
B	A	STAND-BY
B	B	STAND-BY
A	A	MUTE
A	B	PLAY

BRIDGE APPLICATION

Another application suggestion concerns the BRIDGE configuration, where the two power amplifiers are connected as shown by the schematic diagram of figure. 18.

This application shows, however, some operative limits due to dissipation and current capability of the output stage. For this reason, we recommend to use the TDA7265 in bridge with the supply voltage equal/lower than $\pm 16V$ when the load is 8Ω ; with higher loads (i.e. 16Ω), the amplifier can work correctly in the whole supply voltage range.

The detected characteristics of T.H.D. vs P_{out} and Frequency Response are shown in fig.19 and fig.20.

With $R_L=8\Omega$, $V_s=\pm 16V$ the maximum output power obtainable is 50W at T.D.H.=10%.

The quiescent current remains unchanged with respect to the stereo configuration ($\sim 80mA$ as typical at $V_s=\pm 16V$).

The last point to take into consideration concerns the short-circuit protection. As for the stereo application, the TDA7265 is fully protected against any kind of short-circuit (between Out/Gnd, Out/+Vs and Out/-Vs).

Figure 18: Bridge Application Circuit

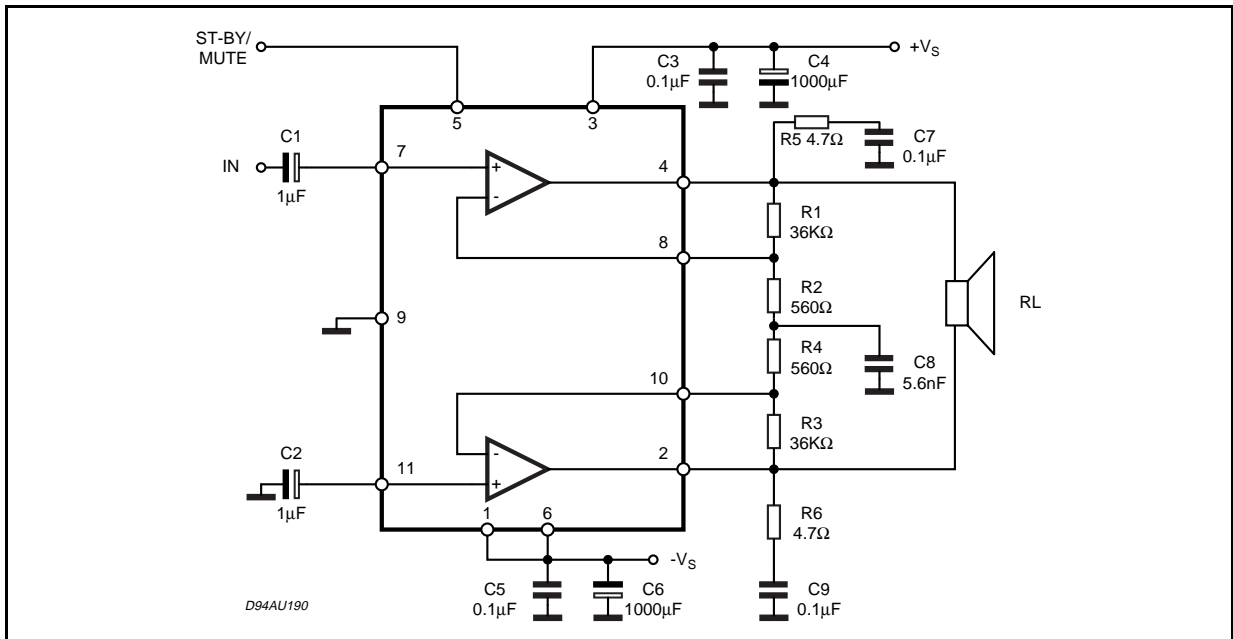

Figure 19: Distortion vs. Output Power

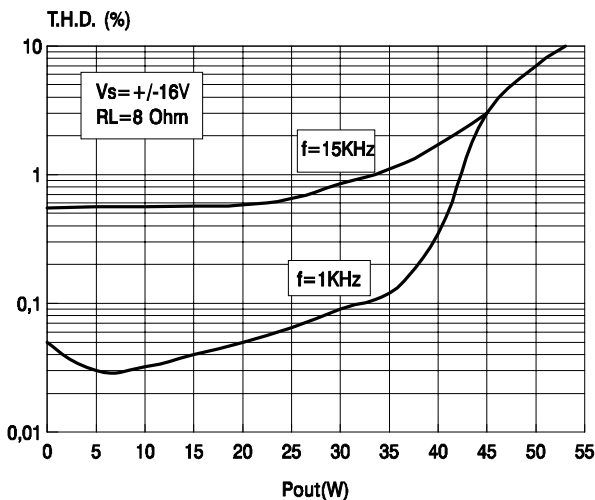
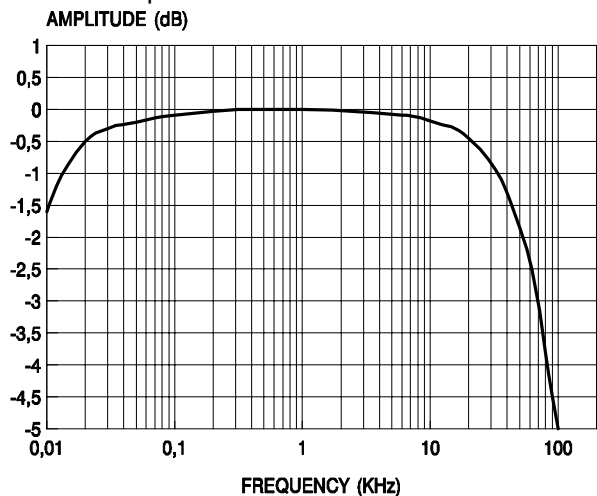
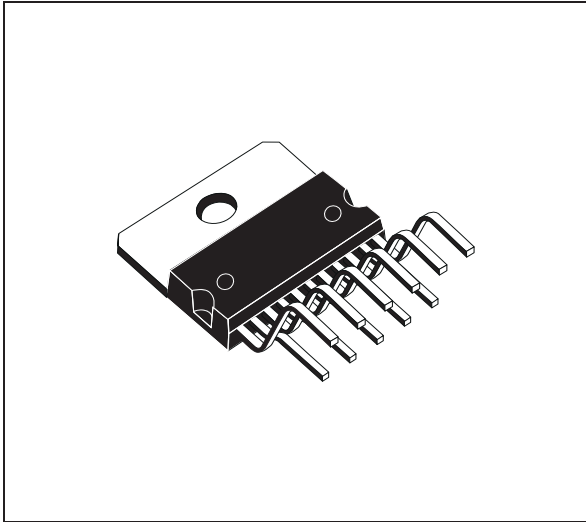

Figure 20: Frequency Response of the Bridge Applications



DIM.	mm			inch		
	MIN.	TYP.	MAX.	MIN.	TYP.	MAX.
A			5			0.197
B			2.65			0.104
C			1.6			0.063
D		1			0.039	
E	0.49		0.55	0.019		0.022
F	0.88		0.95	0.035		0.037
G	1.45	1.7	1.95	0.057	0.067	0.077
G1	16.75	17	17.25	0.659	0.669	0.679
H1	19.6			0.772		
H2			20.2			0.795
L	21.9	22.2	22.5	0.862	0.874	0.886
L1	21.7	22.1	22.5	0.854	0.87	0.886
L2	17.4		18.1	0.685		0.713
L3	17.25	17.5	17.75	0.679	0.689	0.699
L4	10.3	10.7	10.9	0.406	0.421	0.429
L7	2.65		2.9	0.104		0.114
M	4.25	4.55	4.85	0.167	0.179	0.191
M1	4.73	5.08	5.43	0.186	0.200	0.214
S	1.9		2.6	0.075		0.102
S1	1.9		2.6	0.075		0.102
Dia1	3.65		3.85	0.144		0.152

OUTLINE AND MECHANICAL DATA



Multiwatt11 V

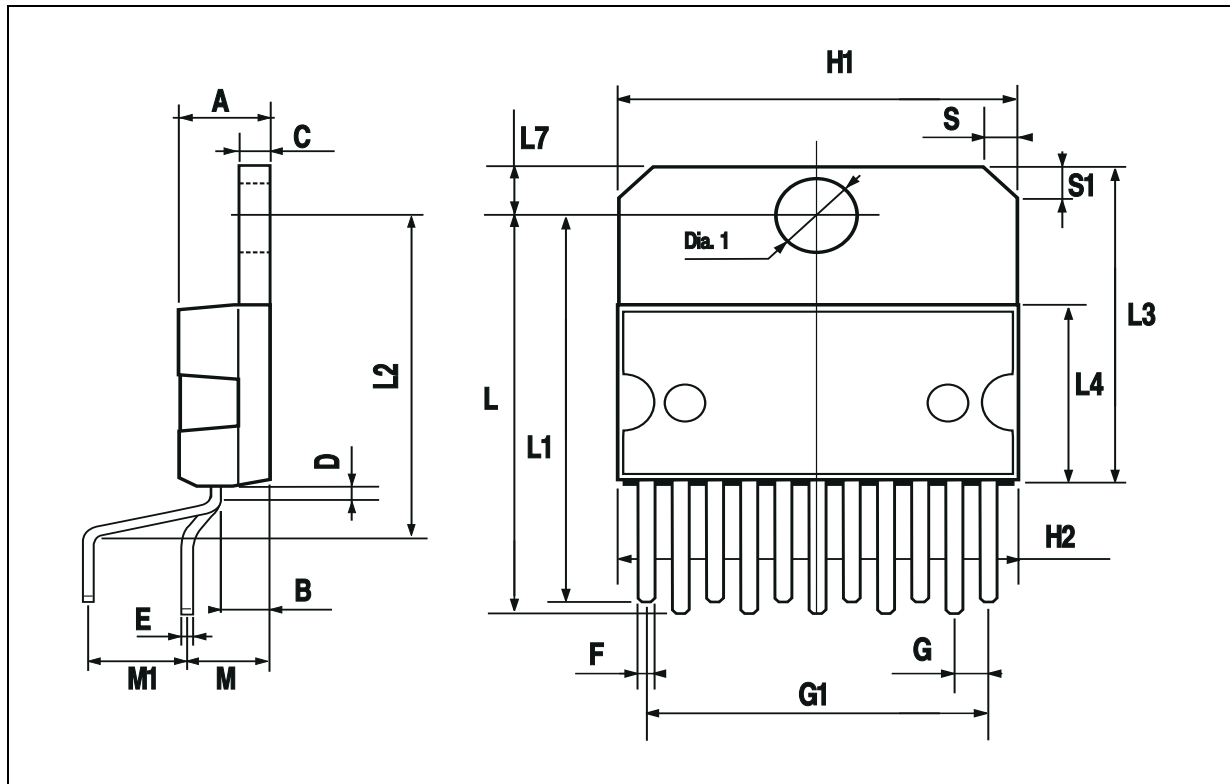

Information furnished is believed to be accurate and reliable. However, STMicroelectronics assumes no responsibility for the consequences of use of such information nor for any infringement of patents or other rights of third parties which may result from its use. No license is granted by implication or otherwise under any patent or patent rights of STMicroelectronics. Specification mentioned in this publication are subject to change without notice. This publication supersedes and replaces all information previously supplied. STMicroelectronics products are not authorized for use as critical components in life support devices or systems without express written approval of STMicroelectronics.

The ST logo is a registered trademark of STMicroelectronics
©2002 STMicroelectronics – Printed in Italy – All Rights Reserved

STMicroelectronics GROUP OF COMPANIES
Australia - Brazil - Canada - China - Finland - France - Germany - Hong Kong - India - Israel - Italy - Japan - Malaysia - Malta - Morocco
Singapore - Spain - Sweden - Switzerland - United Kingdom - United States.
<http://www.st.com>



Looking for pricing, stock, or lifecycle information?

Click below to explore more details on WIN SOURCE:

- ⊖ [View TDA7264](#) on WIN SOURCE
- ⊖ [STMicroelectronics](#) Information

Optimize Your Supply Chain with WIN SOURCE Solutions

- ✓ Global Sourcing Solution
- ✓ Obsolete Management
- ✓ Cost Control Management
- ✓ Shortage Management
- ✓ Alternative Solution
- ✓ Excess Inventory Management