

---

# ST-NXP Wireless

## IMPORTANT NOTICE

Dear customer,

As from August 2<sup>nd</sup> 2008, the wireless operations of NXP have moved to a new company, ST-NXP Wireless.

As a result, the following changes are applicable to the attached document.

- **Company name - Philips Semiconductors** is replaced with **ST-NXP Wireless**.
- **Copyright** - the copyright notice at the bottom of each page “© Koninklijke Philips Electronics N.V. 200x. All rights reserved”, shall now read: “© ST-NXP Wireless 200x - All rights reserved”.
- **Web site** - <http://www.semiconductors.philips.com> is replaced with <http://www.stnwireless.com>
- **Contact information** - the list of sales offices previously obtained by sending an email to [sales.addresses@www.semiconductors.philips.com](mailto:sales.addresses@www.semiconductors.philips.com), is now found at <http://www.stnwireless.com> under Contacts.

If you have any questions related to the document, please contact our nearest sales office. Thank you for your cooperation and understanding.

ST-NXP Wireless

# DATA SHEET

## **TDA7021T** FM radio circuit for MTS

Product specification  
File under Integrated Circuits, IC01

May 1992

## FM radio circuit for MTS

## TDA7021T

### GENERAL DESCRIPTION

The TDA7021T integrated radio receiver circuit is for portable radios, stereo as well as mono, where a minimum of periphery is important in terms of small dimensions and low cost. It is fully compatible for applications using the low-voltage micro tuning system (MTS). The IC has a frequency locked loop (FLL) system with an intermediate frequency of 76 kHz. The selectivity is obtained by active RC filters. The only function to be tuned is the resonant frequency of the oscillator. Interstation noise as well as noise from receiving weak signals is reduced by a correlation mute system.

Special precautions have been taken to meet local oscillator radiation requirements. Because of the low intermediate frequency, low pass filtering of the MUX signal is required to avoid noise when receiving stereo. 50 kHz roll-off compensation, needed because of the low pass characteristic of the FLL, is performed by the integrated LF amplifier. For mono application this amplifier can be used to directly drive an earphone. The field-strength detector enables field-strength dependent channel separation control.

### Features

- RF input stage
- Mixer
- Local oscillator
- IF amplifier/limiter
- Frequency detector
- Mute circuit
- MTS compatible
- Loop amplifier
- Internal reference circuit
- LF amplifier for
  - mono earphone amplifier or
  - MUX filter
- Field-strength dependent channel separation control facility

### QUICK REFERENCE DATA

PARAMETER	CONDITIONS	SYMBOL	MIN.	TYP.	MAX.	UNIT
Supply voltage (pin 4)		$V_P = V_{4-3}$	1,8	–	6,0	V
Supply current	$V_P = 3\text{ V}$	$I_4$	–	6,3	–	mA
RF input frequency		$f_{rf}$	1,5	–	110	MHz
Sensitivity (e.m.f.) for –3 dB limiting	source impedance = 75 $\Omega$ ; mute disabled	EMF	–	4	–	$\mu\text{V}$
Signal handling (e.m.f.)	source impedance = 75 $\Omega$	EMF	–	200	–	mV
AF output voltage		$V_o$	–	90	–	mV

### PACKAGE OUTLINE

16-lead mini-pack; plastic (SO 16; SOT109A); SOT109-1; 1996 July 24.

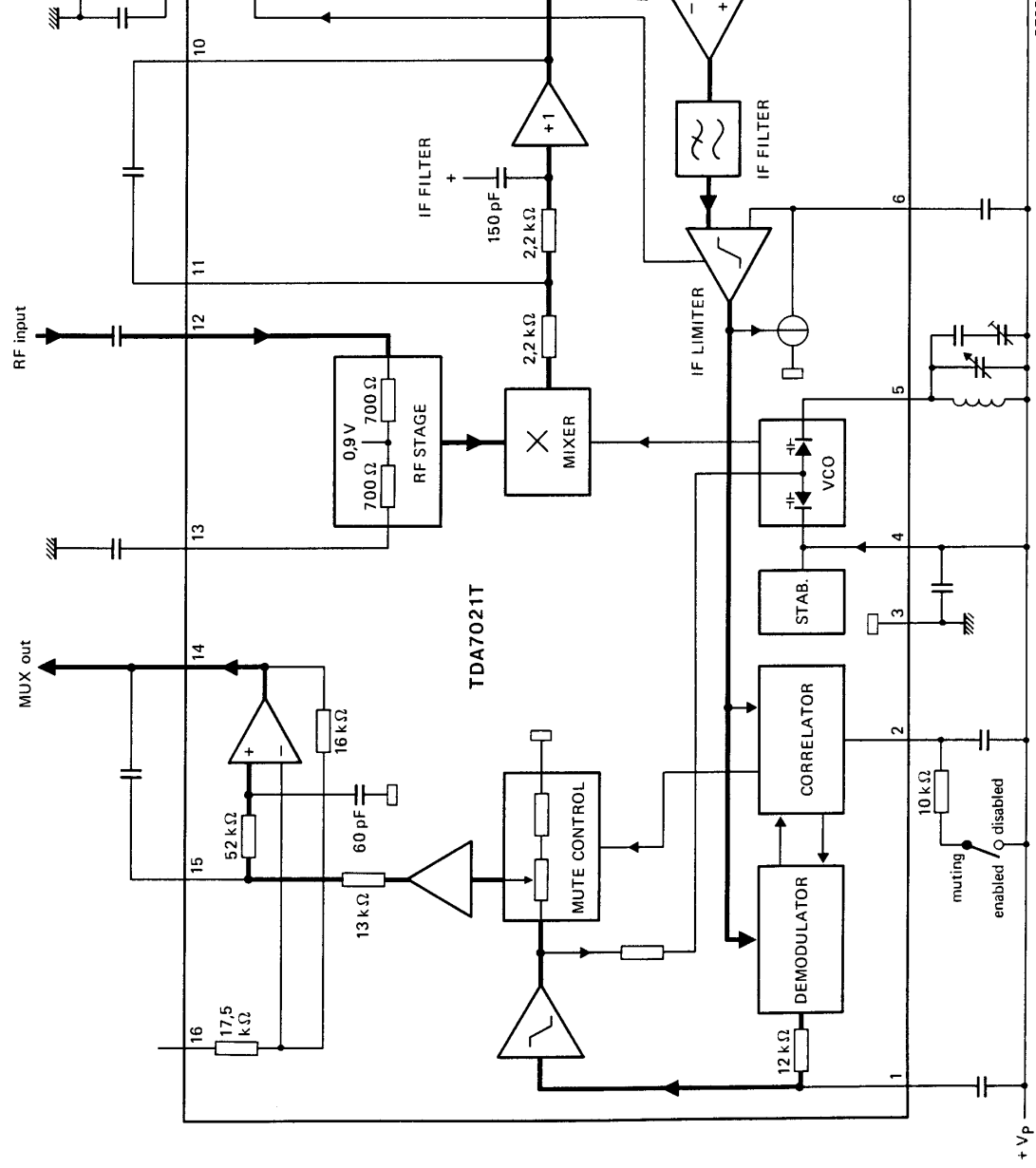

Fig.1 Block diagram.

+ Vp

7297

FM radio circuit for MTS

TDA7021T

**RATINGS**

Limiting values in accordance with the Absolute Maximum System (IEC 134)

PARAMETER	CONDITIONS	SYMBOL	MIN.	MAX.	UNIT
Supply voltage (pin 4)		$V_P = V_{4-3}$	-	7,0	V
Oscillator voltage		$V_{5-4}$	$V_P - 0,5$	$V_P + 0,5$	V
Storage temperature range		$T_{stg}$	-55	+150	°C
Operating ambient temperature range		$T_{amb}$	-10	+70	°C

**THERMAL RESISTANCE**

From junction to ambient

$R_{th\ j-a} = 300 \text{ K/W}$

**DC CHARACTERISTICS**

$V_P = 3 \text{ V}$ ,  $T_{amb} = 25 \text{ °C}$ , measured in circuit of Fig.4, unless otherwise specified

PARAMETER	CONDITIONS	SYMBOL	MIN.	TYP.	MAX.	UNIT
Supply voltage (pin 4)		$V_P = V_{4-3}$	1,8	3,0	6,0	V
Supply current	$V_P = 3 \text{ V}$	$I_4$	-	6,3	-	mA
Oscillator current		$I_5$	-	250	-	µA
Voltage at pin 13		$V_{13-3}$	-	0,9	-	V
Output voltage (pin 14)		$V_{14-3}$	-	1,3	-	V

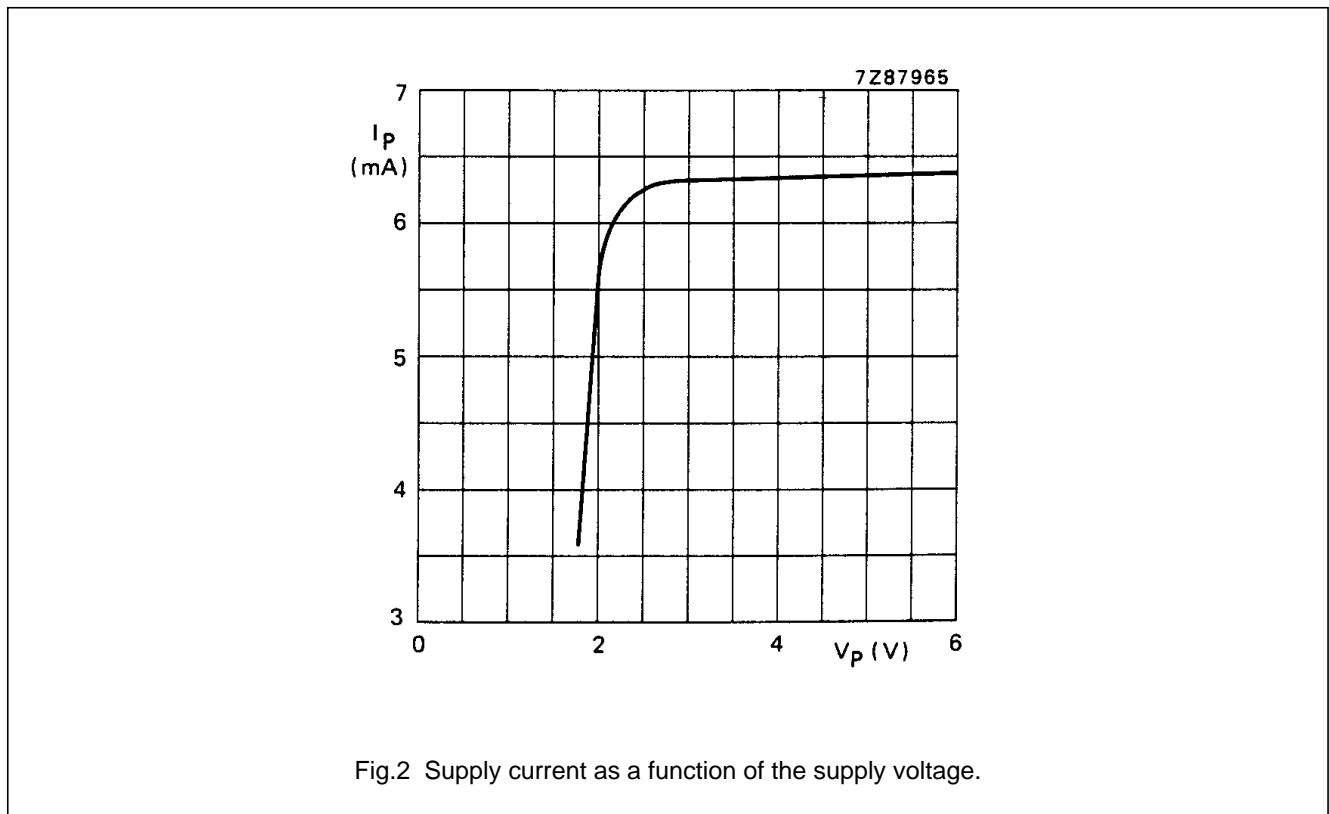

Fig.2 Supply current as a function of the supply voltage.

## FM radio circuit for MTS

## TDA7021T

**AC CHARACTERISTICS (MONO OPERATION)**

$V_P = 3\text{ V}$ ;  $T_{\text{amb}} = 25\text{ °C}$ ; measured in Fig.5;  $f_{\text{rf}} = 96\text{ MHz}$  modulated with  $\Delta f = \pm 22,5\text{ kHz}$ ;  $f_m = 1\text{ kHz}$ ;  $\text{EMF} = 0,3\text{ mV}$  (e.m.f. at a source impedance of  $75\ \Omega$ ); r.m.s. noise voltage measured unweighted ( $f = 300\text{ Hz}$  to  $20\text{ kHz}$ ); unless otherwise specified

PARAMETER	CONDITIONS	SYMBOL	MIN.	TYP.	MAX.	UNIT
Sensitivity (e.m.f.)	see Fig.3					
for $-3\text{ dB}$ limiting	muting disabled	EMF	–	4,0	–	$\mu\text{V}$
for $-3\text{ dB}$ muting		EMF	–	5,0	–	$\mu\text{V}$
for $(\text{S}+\text{N})/\text{N} = 26\text{ dB}$		EMF	–	7,0	–	$\mu\text{V}$
Signal handling (e.m.f.)	THD < 10%; $\Delta f = \pm 75\text{ kHz}$	EMF	–	200	–	mV
Signal-to-noise ratio		$(\text{S}+\text{N})/\text{N}$	–	60	–	dB
Total harmonic distortion	$\Delta f = \pm 22,5\text{ kHz}$	THD	–	0,7	–	%
	$\Delta f = \pm 75\text{ kHz}$	THD	–	2,3	–	%
AM suppression of output voltage	ratio of AM signal ( $f_m = 1\text{ kHz}$ ; $m = 80\%$ ) to FM signal ( $f_m = 1\text{ kHz}$ ; $\Delta f = 75\text{ kHz}$ )	AMS	–	50	–	dB
Ripple rejection	$\Delta V_P = 100\text{ mV}$ ; $f = 1\text{ kHz}$	RR	–	30	–	dB
Oscillator voltage (r.m.s. value)		$V_{5-4(\text{rms})}$	–	250	–	mV
Variation of oscillator frequency with temperature	$V_P = 1\text{ V}$	$\frac{\Delta f_{\text{osc}}}{\Delta T_{\text{amb}}}$	–	5	–	kHz/°C
Selectivity	see Fig.9; no modulation					
		$S_{+300}$	–	46	–	dB
		$S_{-300}$	–	30	–	dB
AFC range		$\pm \Delta f_{\text{rf}}$	–	160	–	kHz
Mute range		$\pm \Delta f_{\text{rf}}$	–	120	–	kHz
Audio bandwidth	$\Delta V_o = 3\text{ dB}$ ; measured with $50\ \mu\text{s}$ pre-emphasis	B	–	10	–	kHz
AF output voltage (r.m.s. value)	$R_L$ (pin 14) = $100\ \Omega$	$V_{o(\text{rms})}$	–	90	–	mV
AF output current max. d.c. load		$I_{o(\text{dc})}$	–100	–	+100	$\mu\text{A}$
AF output current max. a.c. load (peak value)	THD = 10%	$I_{o(\text{ac})}$	–	3	–	mA

FM radio circuit for MTS

TDA7021T

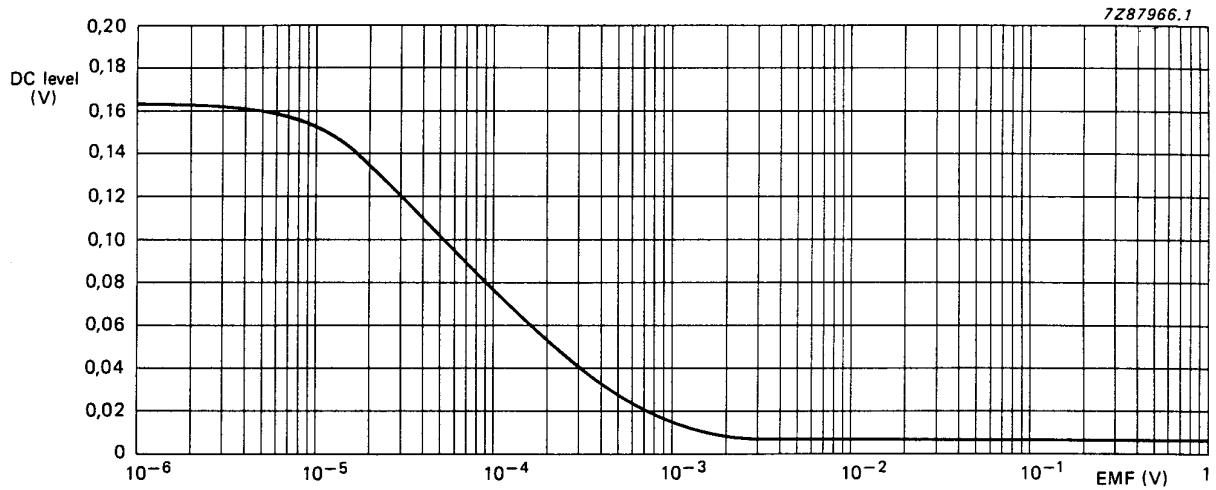

Fig.3 Field strength voltage ( $V_{9.3}$ ) at  $R_{source} = 1 \text{ k}\Omega$ ;  $f = 96,75 \text{ MHz}$ ;  $V_p = 3 \text{ V}$ .

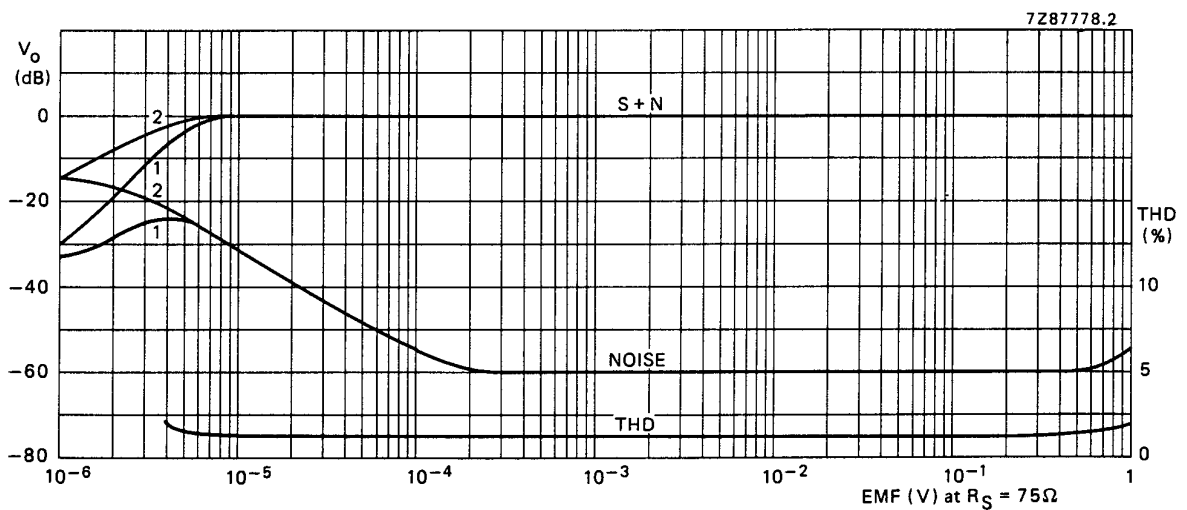
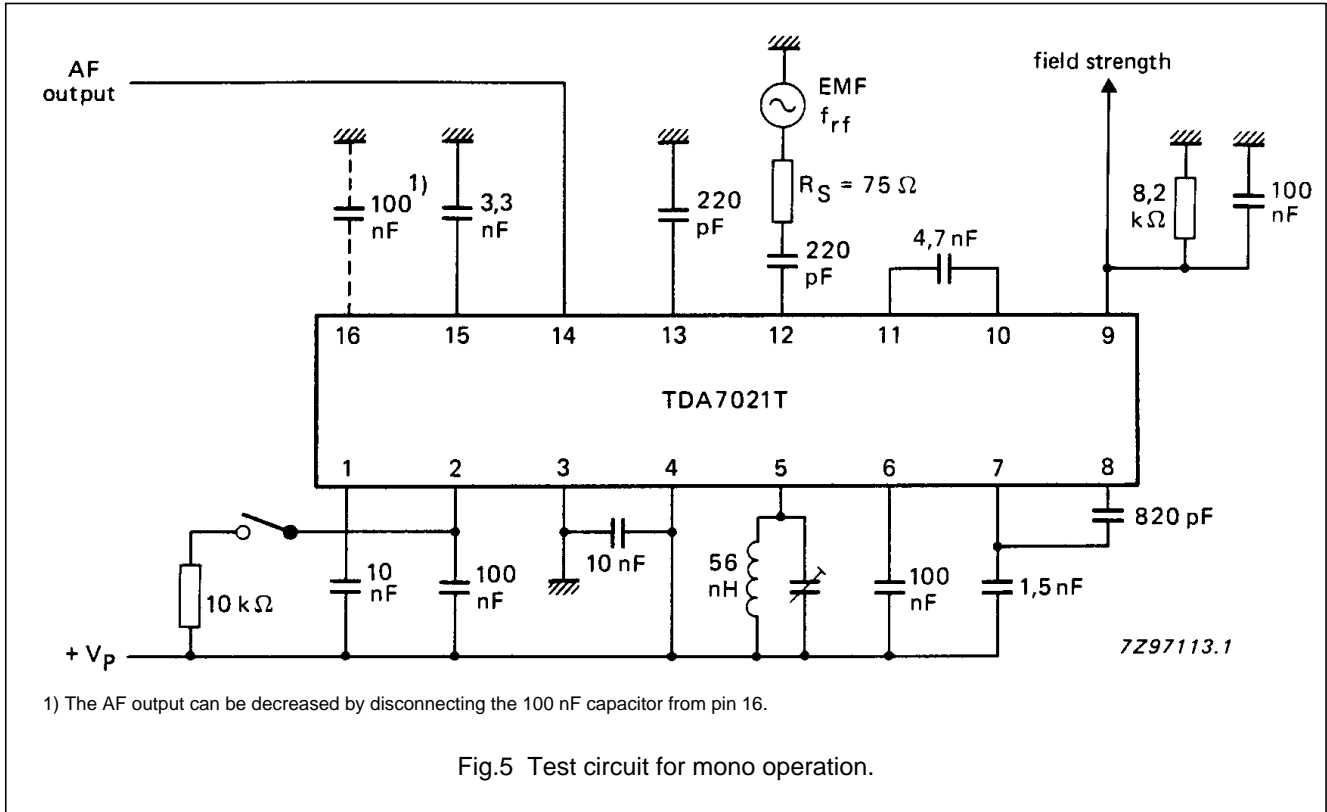

Fig.4 Mono operation: AF output voltage ( $V_o$ ) and total harmonic distortion (THD) as functions of input e.m.f. (EMF);  $R_{source} = 75 \Omega$ ;  $f_{rf} = 96 \text{ MHz}$ ;  $0 \text{ dB} = 90 \text{ mV}$ . For S+N and noise curves (1) is with muting enabled and (2) is with muting disabled; signal  $\Delta f = \pm 22,5 \text{ kHz}$  and  $f_m = 1 \text{ kHz}$ . For THD curve,  $\Delta f = \pm 75 \text{ kHz}$  and  $f_m = 1 \text{ kHz}$ .

FM radio circuit for MTS

TDA7021T



AC CHARACTERISTICS (STEREO OPERATION)

$V_p = 3\text{ V}$ ;  $T_{amb} = 25\text{ }^\circ\text{C}$ ; measured in Fig.8;  $f_{rf} = 96\text{ MHz}$  modulated with pilot  $\Delta f = \pm 6,75\text{ kHz}$  and AF signal  $\Delta f = \pm 22,5\text{ kHz}$ ;  $f_m = 1\text{ kHz}$ ; EMF = 1 mV (e.m.f. at a source impedance of 75  $\Omega$ ); r.m.s. noise voltage measured unweighted ( $f = 300\text{ Hz}$  to 20 kHz); unless otherwise specified

PARAMETER	CONDITIONS	SYMBOL	MIN.	TYP.	MAX.	UNIT
Sensitivity (e.m.f.) for $(S+N)/N = 26\text{ dB}$	see Fig.8; pilot off	EMF	—	11	—	$\mu\text{V}$
Selectivity	see Fig.9; no modulation	$S_{+300}$	—	40	—	dB
		$S_{-300}$	—	22	—	dB
Signal-to-noise ratio		$(S+N)/N$	—	50	—	dB
Channel separation	$V_i = \text{L-signal}$ ; $f_m = 1\text{ kHz}$ ; pilot on: at $f_{rf} = 97\text{ MHz}$	$\alpha$	—	26	—	dB
	at $f_{rf} = 87,5\text{ MHz}$ and 108 MHz	$\alpha$	—	14	—	dB

FM radio circuit for MTS

TDA7021T

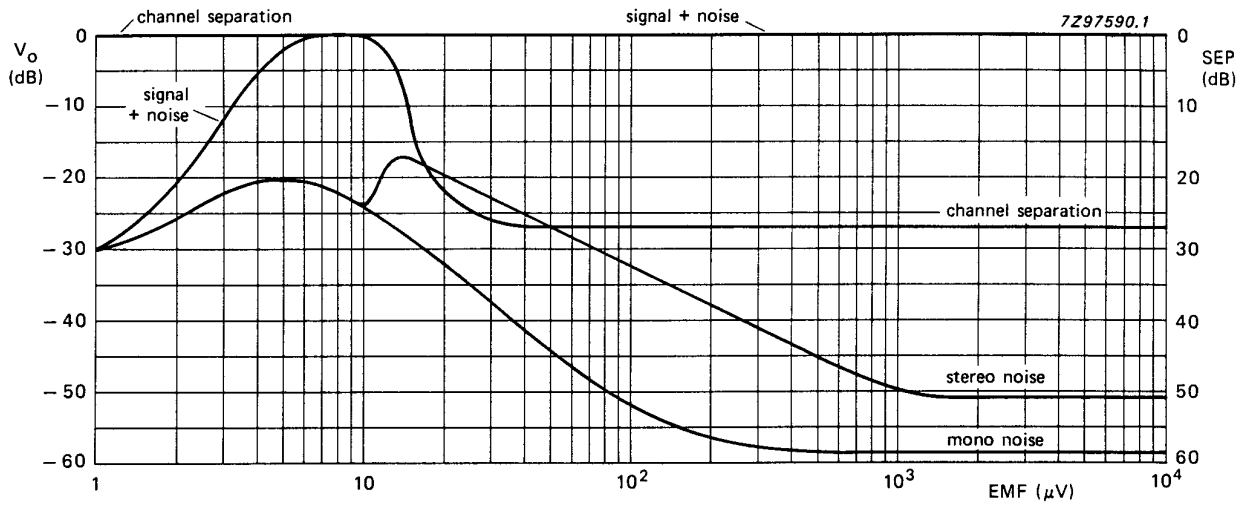

Fig.6 Stereo operation: signal/noise and channel separation of TDA7021T when used in the circuit of Fig.8.

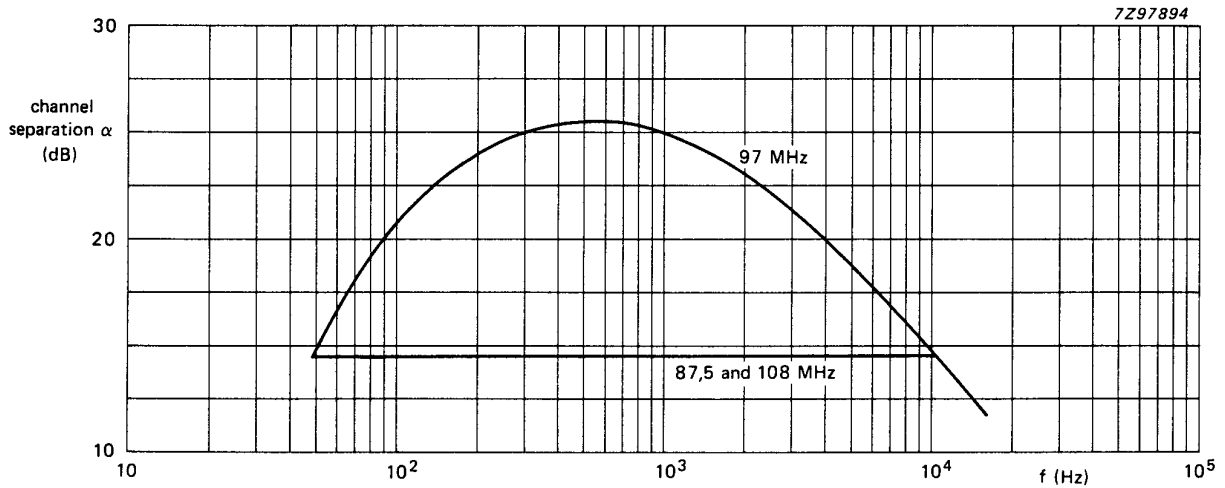

Fig.7 Stereo operation: channel separation as a function of audio frequency in the circuit of Fig.8.

FM radio circuit for MTS

TDA7021T

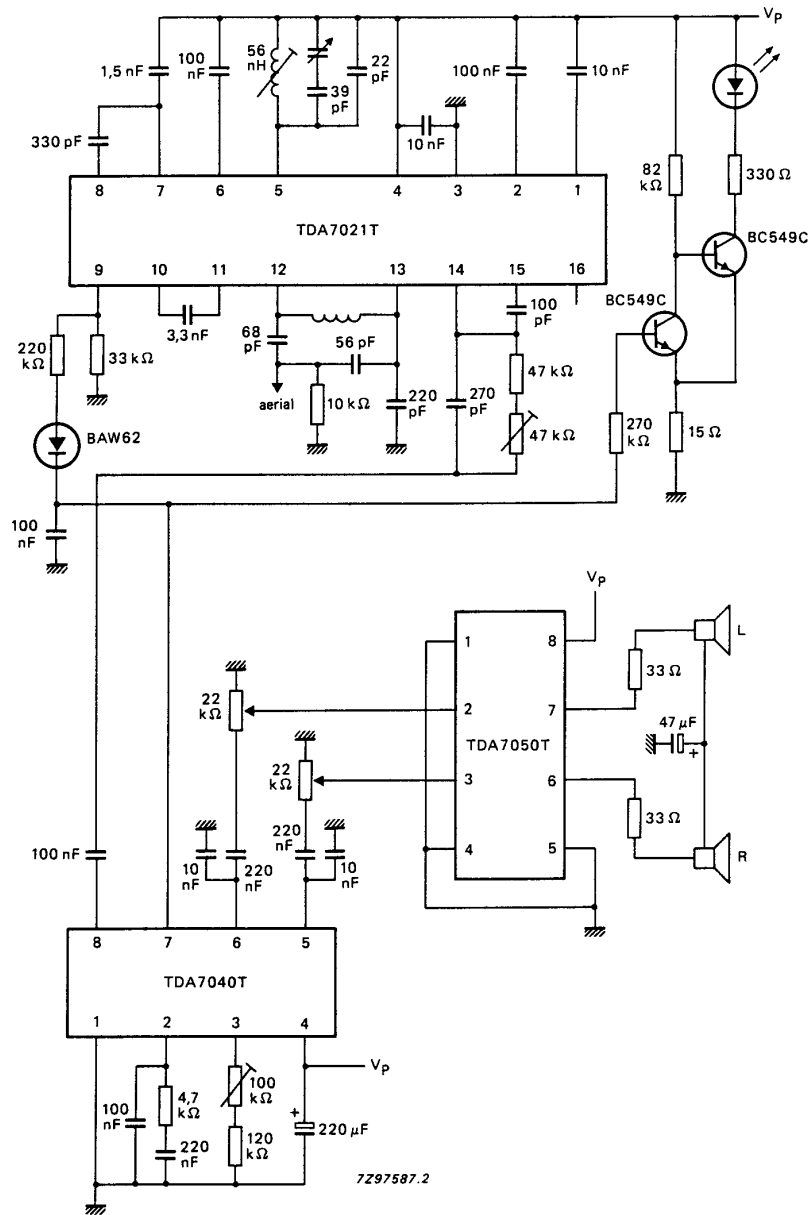

Fig.8 Stereo application in combination with a low voltage PLL stereo decoder (TDA7040T) and a low voltage mono/stereo power amplifier (TDA7050T).

FM radio circuit for MTS

TDA7021T

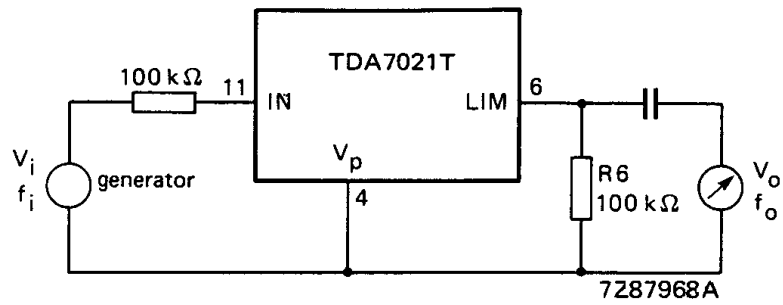

Fig.9 Test set-up;  $V_i = 30 \text{ mV}$ ;  $f_i = 76 \text{ kHz}$ ; selective voltmeter at output has  $R_i \geq 1 \text{ M}\Omega$  and  $C_i \leq 8 \text{ pF}$ ;  $f_o = f_i$ .

**Note to Fig. 9**

This test set-up is to incorporate the circuit of Fig.5 for mono operation or the circuit of Fig.8 for stereo operation. For either circuit, replace the 100 nF capacitor at pin 6 with R6 (100 kΩ) as shown above.

**Selectivity**

$$S_{+300} = 20 \log \frac{V_o | (300 \text{ kHz} - f_i)}{V_o | f_i}$$

$$S_{-300} = 20 \log \frac{V_o | (300 \text{ kHz} + f_i)}{V_o | f_i}$$

FM radio circuit for MTS

TDA7021T

PACKAGE OUTLINE

SO16: plastic small outline package; 16 leads; body width 3.9 mm

SOT109-1

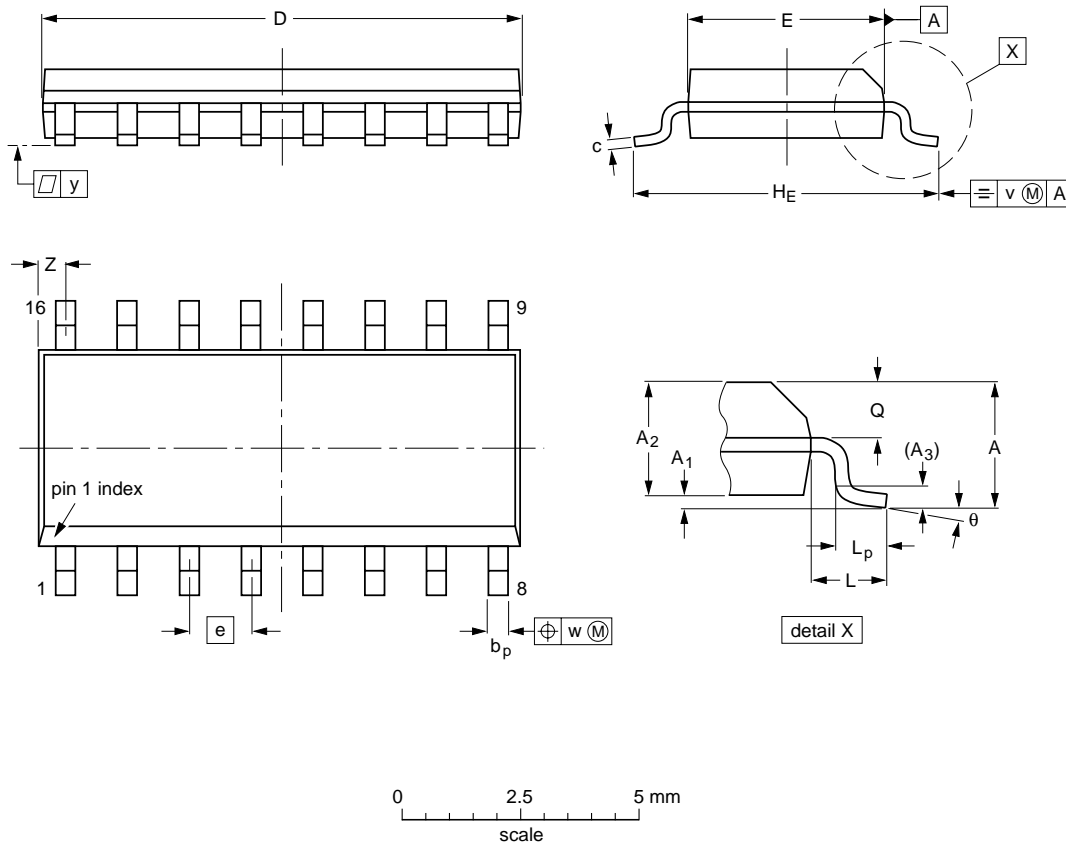

DIMENSIONS (inch dimensions are derived from the original mm dimensions)

UNIT	A max.	A <sub>1</sub>	A <sub>2</sub>	A <sub>3</sub>	b <sub>p</sub>	c	D <sup>(1)</sup>	E <sup>(1)</sup>	e	H <sub>E</sub>	L	L <sub>p</sub>	Q	v	w	y	Z <sup>(1)</sup>	θ
mm	1.75	0.25 0.10	1.45 1.25	0.25	0.49 0.36	0.25 0.19	10.0 9.8	4.0 3.8	1.27	6.2 5.8	1.05	1.0 0.4	0.7 0.6	0.25	0.25	0.1	0.7 0.3	8° 0°
inches	0.069	0.010 0.004	0.057 0.049	0.01	0.019 0.014	0.0100 0.0075	0.39 0.38	0.16 0.15	0.050	0.244 0.228	0.041	0.039 0.016	0.028 0.020	0.01	0.01	0.004	0.028 0.012	

Note

1. Plastic or metal protrusions of 0.15 mm maximum per side are not included.

OUTLINE VERSION	REFERENCES				EUROPEAN PROJECTION	ISSUE DATE
	IEC	JEDEC	EIAJ			
SOT109-1	076E07S	MS-012AC				95-01-23 97-05-22

---

## FM radio circuit for MTS

## TDA7021T

---

### SOLDERING

#### Introduction

There is no soldering method that is ideal for all IC packages. Wave soldering is often preferred when through-hole and surface mounted components are mixed on one printed-circuit board. However, wave soldering is not always suitable for surface mounted ICs, or for printed-circuits with high population densities. In these situations reflow soldering is often used.

This text gives a very brief insight to a complex technology. A more in-depth account of soldering ICs can be found in our *"IC Package Databook"* (order code 9398 652 90011).

#### Reflow soldering

Reflow soldering techniques are suitable for all SO packages.

Reflow soldering requires solder paste (a suspension of fine solder particles, flux and binding agent) to be applied to the printed-circuit board by screen printing, stencilling or pressure-syringe dispensing before package placement.

Several techniques exist for reflowing; for example, thermal conduction by heated belt. Dwell times vary between 50 and 300 seconds depending on heating method. Typical reflow temperatures range from 215 to 250 °C.

Preheating is necessary to dry the paste and evaporate the binding agent. Preheating duration: 45 minutes at 45 °C.

#### Wave soldering

Wave soldering techniques can be used for all SO packages if the following conditions are observed:

- A double-wave (a turbulent wave with high upward pressure followed by a smooth laminar wave) soldering technique should be used.
- The longitudinal axis of the package footprint must be parallel to the solder flow.
- The package footprint must incorporate solder thieves at the downstream end.

During placement and before soldering, the package must be fixed with a droplet of adhesive. The adhesive can be applied by screen printing, pin transfer or syringe dispensing. The package can be soldered after the adhesive is cured.

Maximum permissible solder temperature is 260 °C, and maximum duration of package immersion in solder is 10 seconds, if cooled to less than 150 °C within 6 seconds. Typical dwell time is 4 seconds at 250 °C.

A mildly-activated flux will eliminate the need for removal of corrosive residues in most applications.

#### Repairing soldered joints

Fix the component by first soldering two diagonally-opposite end leads. Use only a low voltage soldering iron (less than 24 V) applied to the flat part of the lead. Contact time must be limited to 10 seconds at up to 300 °C. When using a dedicated tool, all other leads can be soldered in one operation within 2 to 5 seconds between 270 and 320 °C.

## FM radio circuit for MTS

## TDA7021T

**DEFINITIONS**

<b>Data sheet status</b>	
Objective specification	This data sheet contains target or goal specifications for product development.
Preliminary specification	This data sheet contains preliminary data; supplementary data may be published later.
Product specification	This data sheet contains final product specifications.
<b>Limiting values</b>	
Limiting values given are in accordance with the Absolute Maximum Rating System (IEC 134). Stress above one or more of the limiting values may cause permanent damage to the device. These are stress ratings only and operation of the device at these or at any other conditions above those given in the Characteristics sections of the specification is not implied. Exposure to limiting values for extended periods may affect device reliability.	
<b>Application information</b>	
Where application information is given, it is advisory and does not form part of the specification.	

**LIFE SUPPORT APPLICATIONS**

These products are not designed for use in life support appliances, devices, or systems where malfunction of these products can reasonably be expected to result in personal injury. Philips customers using or selling these products for use in such applications do so at their own risk and agree to fully indemnify Philips for any damages resulting from such improper use or sale.

## Looking for pricing, stock, or lifecycle information?

Click below to explore more details on WIN SOURCE:

- ⊖ [View TDA7021T/V4 on WIN SOURCE](#)
- ⊖ [NXP / Nexperia Information](#)

## Optimize Your Supply Chain with WIN SOURCE Solutions

- ✓ Global Sourcing Solution
- ✓ Obsolete Management
- ✓ Cost Control Management
- ✓ Shortage Management
- ✓ Alternative Solution
- ✓ Excess Inventory Management