



# THE DATASHEET OF TDA3681ATH/N1S



# DATA SHEET

## **TDA3681A**

Multiple voltage regulator with  
switch and ignition buffer

Product specification

2003 Aug 29

## Multiple voltage regulator with switch and ignition buffer

## TDA3681A

### FEATURES

#### General

- Extremely low noise behaviour and good stability with very small output capacitors
- Second supply pin for regulators 3 and 4 to reduce power dissipation (e.g. via a DC-to-DC converter)
- Three  $V_P$ -state controlled regulators (regulators 1, 3 and 4) and a power switch
- Regulator 2, reset and ignition buffer operational during load dump and thermal shutdown
- Combined control pin for switching regulators 1 and 3
- Separate control pins for switching regulator 4 and the power switch
- Supply voltage range from  $-18\text{ V}$  to  $+50\text{ V}$
- Low quiescent current in standby mode (when regulators 1, 3 and 4 and power switch are switched off and ignition input is low)
- Hold output for low  $V_P$ , load dump and temperature protection
- Reset (push-pull output stage) for regulator 2 and hold output (open-collector output)
- Adjustable reset delay time
- High supply voltage ripple rejection
- Backup capacitor for regulator 2
- One independent ignition buffer (active HIGH).

#### Protections

- Reverse polarity safe (down to  $-18\text{ V}$  without high reverse current)
- Able to withstand voltages up to  $18\text{ V}$  at the outputs (supply line may be short-circuited)
- ESD protection on all pins
- Thermal protections
- Load dump protection

- Foldback current limit protection for regulators 1, 2, 3 and 4
- Delayed second current limit protection for the power switch (at short circuit)
- The regulator outputs and the power switch are DC short-circuit safe to ground and supply ( $V_P$ ).

### GENERAL DESCRIPTION

The TDA3681A is a multiple output voltage regulator with a power switch and an ignition buffer. It is intended for use in car radios with or without a microcontroller.

The TDA3681A contains the following:

- Four fixed voltage regulators with a foldback current protection (regulators 1, 2, 3 and 4). Regulator 2, which is intended to supply a microcontroller, also operates during load dump and thermal shutdown
- Regulators 3 and 4 have a second supply pin that can be connected to a lower supply voltage ( $> 6.5\text{ V}$ ) to reduce the power dissipation
- A power switch with protection, operated by a control input
- Reset and hold outputs that can be used to interface with the microcontroller; the reset signal can be used to call up the microcontroller
- Both supply pins can withstand load dump pulses and negative supply voltages
- Regulator 2, which is in regulation at a backup voltage above  $6.5\text{ V}$
- A provision for the use of a reserve supply capacitor that will hold enough energy for regulator 2 ( $5\text{ V}$  continuous) to allow a microcontroller to prepare for loss of voltage
- An ignition input Schmitt trigger with push-pull output stage.

### ORDERING INFORMATION

| TYPE NUMBER | PACKAGE |   |          |
|-------------|---------|---|----------|
|             | NAME    | DESCRIPTION   | VERSION  |
| TDA3681ATH  | HSOP20  | plastic, heatsink small outline package; 20 leads; low stand-off height | SOT418-3 |

# Multiple voltage regulator with switch and ignition buffer

TDA3681A

## QUICK REFERENCE DATA

| SYMBOL                    | PARAMETER                      | CONDITIONS  | MIN. | TYP. | MAX. | UNIT |
|---------------------------|--------------------------------|---|------|------|------|------|
| <b>Supplies</b>           |                                |   |      |      |      |      |
| V <sub>P1</sub>           | supply voltage 1<br>operating  |   | 9.5  | 14.4 | 18   | V    |
|                           | reverse polarity               | non-operating   | –    | –    | 18   | V    |
|                           | regulator 2 on                 |   | 4    | 14.4 | 50   | V    |
|                           | jump start                     | t ≤ 10 minutes  | –    | –    | 30   | V    |
|                           | load dump protection           | t ≤ 50 ms; t <sub>r</sub> ≥ 2.5 ms                          | –    | –    | 50   | V    |
| V <sub>P2</sub>           | supply voltage 2<br>operating  |   | 6.5  | 14.4 | 18   | V    |
|                           | reverse polarity               | non-operating   | –    | –    | 18   | V    |
|                           | regulator 2 on                 |   | 0    | –    | 50   | V    |
|                           | jump start                     | t ≤ 10 minutes  | –    | –    | 30   | V    |
|                           | load dump protection           | t ≤ 50 ms; t <sub>r</sub> ≥ 2.5 ms                          | –    | –    | 50   | V    |
| I <sub>q(tot)</sub>       | total quiescent supply current | standby mode  | –    | 110  | 150  | μA   |
| T <sub>j</sub>            | junction temperature           |   | –    | –    | 150  | °C   |
| <b>Voltage regulators</b> |                                |   |      |      |      |      |
| V <sub>o(REG1)</sub>      | output voltage of regulator 1  | 1 mA ≤ I <sub>REG1</sub> ≤ 600 mA; V <sub>P</sub> = 14.4 V  | 8.0  | 8.5  | 9.0  | V    |
| V <sub>o(REG2)</sub>      | output voltage of regulator 2  | 1 mA ≤ I <sub>REG2</sub> ≤ 300 mA; V <sub>P</sub> = 14.4 V  | 4.75 | 5.0  | 5.25 | V    |
| V <sub>o(REG3)</sub>      | output voltage of regulator 3  | 1 mA ≤ I <sub>REG3</sub> ≤ 1400 mA; V <sub>P</sub> = 14.4 V | 4.75 | 5.0  | 5.25 | V    |
| V <sub>o(REG4)</sub>      | output voltage of regulator 4  | 1 mA ≤ I <sub>REG4</sub> ≤ 1 A; V <sub>P</sub> = 14.4 V     | 3.14 | 3.3  | 3.46 | V    |
| <b>Power switch</b>       |                                |   |      |      |      |      |
| V <sub>drop(SW)</sub>     | drop-out voltage               | I <sub>SW</sub> = 1 A; V <sub>P1</sub> = 13.5 V             | –    | 0.45 | 0.65 | V    |
|                           |                                | I <sub>SW</sub> = 1.8 A; V <sub>P1</sub> = 13.5 V           | –    | 1.0  | 1.8  | V    |
| I <sub>M(SW)</sub>        | peak current                   |   | 3    | –    | –    | A    |

# Multiple voltage regulator with switch and ignition buffer

## TDA3681A

### BLOCK DIAGRAM

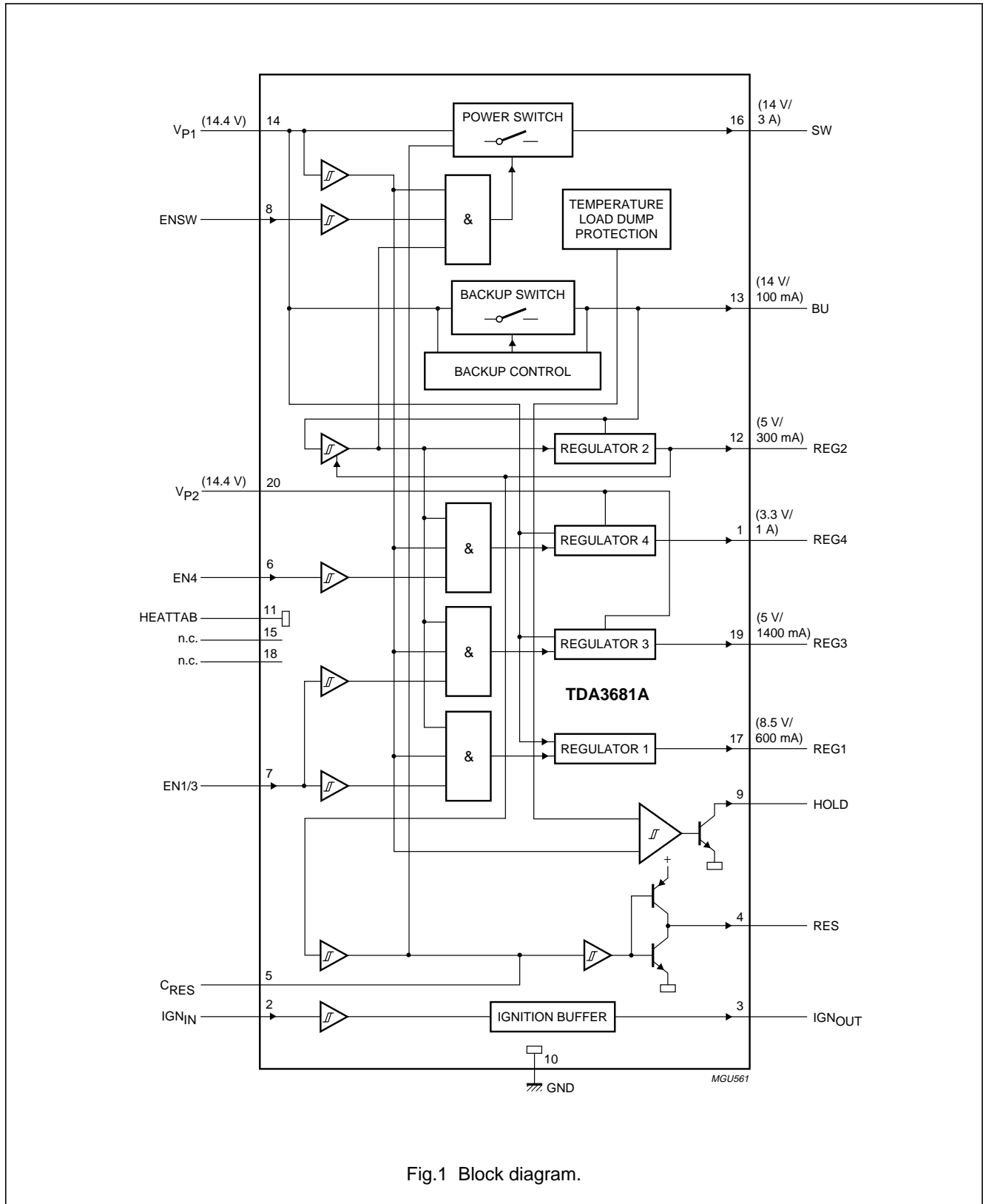

Fig.1 Block diagram.

# Multiple voltage regulator with switch and ignition buffer

TDA3681A

### PINNING

| SYMBOL             | PIN | DESCRIPTION                         |
|--------------------|-----|-------------------------------------|
| REG4               | 1   | regulator 4 output                  |
| IGN <sub>IN</sub>  | 2   | ignition input                      |
| IGN <sub>OUT</sub> | 3   | ignition output (active HIGH)       |
| RES                | 4   | reset output (active LOW)           |
| C <sub>RES</sub>   | 5   | reset delay capacitor               |
| EN4                | 6   | enable input for regulator 4        |
| EN1/3              | 7   | enable input for regulators 1 and 3 |
| ENSW               | 8   | enable input for power switch       |
| HOLD               | 9   | hold output (active LOW)            |
| GND                | 10  | ground                              |
| HEATTAB            | 11  | heat tab connection; note 1         |
| REG2               | 12  | regulator 2 output                  |
| BU                 | 13  | backup switch output                |
| V <sub>P1</sub>    | 14  | first supply voltage                |
| n.c.               | 15  | not connected                       |
| SW                 | 16  | power switch output                 |
| REG1               | 17  | regulator 1 output                  |
| n.c.               | 18  | not connected                       |
| REG3               | 19  | regulator 3 output                  |
| V <sub>P2</sub>    | 20  | second supply voltage               |

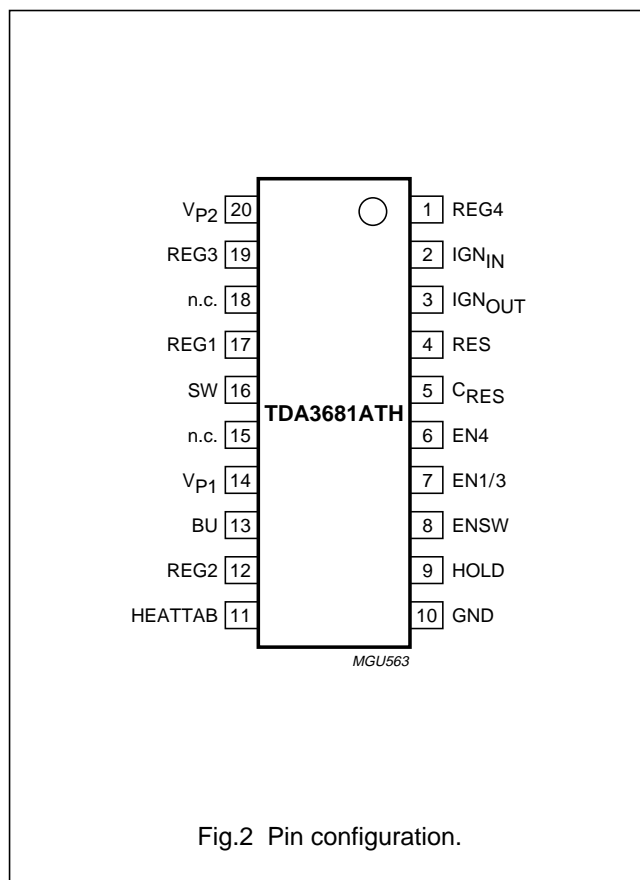

Fig.2 Pin configuration.

### Note

1. The pin is used for final test purposes. In the application it should be connected directly to ground.

# Multiple voltage regulator with switch and ignition buffer

## TDA3681A

### FUNCTIONAL DESCRIPTION

The TDA3681A is a multiple output voltage regulator with a power switch, intended for use in car radios with or without a microcontroller. Because of the low voltage operation of the car radio, low voltage drop regulators are used.

Regulator 2 is in regulation when the backup voltage exceeds 6.5 V for the first time. When regulator 2 is switched on and its output voltage is within its voltage range, the reset output is disabled to release the microcontroller. The reset delay time before release can be extended by an external capacitor ( $C_{CRES}$ ). This start-up feature is included to secure a smooth start-up of the microcontroller at first connection, without uncontrolled switching of regulator 2 during the start-up sequence.

The charge on the backup capacitor can be used to supply regulator 2 for a short period when the external supply voltage drops to 0 V (the time depends on the value of the backup capacitor).

The output stages of all switchable regulators have an extremely low noise behaviour and good stability, even for small values of the output capacitors.

When both regulator 2 and the supply voltages ( $V_{P1}$  and  $V_{P2} > 4.5$  V) are available, regulators 1 and 3 can be operated by means of one enable input.

Regulator 4 and the power switch have a separate enable input.

Pin HOLD is normally HIGH but is active LOW. Pin HOLD is connected to an open-collector NPN transistor and must have an external pull-up resistor to operate. The hold output is controlled by a low battery voltage ( $V_{P1}$ ) detection circuit which, when activated, pulls the hold output LOW (enabled).

The hold circuit is also controlled by the temperature and load dump protection. Activating the temperature or load dump protection causes a hold (LOW) during the time that the protection is activated.

The hold circuit is enabled at low battery voltages. This indicates that it is not possible to get regulator 1 into regulation when switching it on: regulator 1 has the highest output voltage (8.5 V) of all switchable regulators. Therefore, regulator 1 is the most critical regulator with respect to an out of regulation condition caused by a low battery voltage.

The hold function includes hysteresis to avoid oscillations when the battery voltage crosses the hold threshold levels for low  $V_P$  and load dump. The block diagram of the hold function is illustrated in Fig.3.

All output pins are fully protected. The regulators are protected against load dump (regulators 1, 3 and 4 switch off at supply voltages  $> 18$  V) and short-circuit (foldback current protection).

The power switch contains a current protection. However, this protection is delayed at short-circuit by the reset delay capacitor (it should be noted that this is the second function of the reset delay capacitor  $C_{CRES}$ ). During this time, the output current is limited to a peak value of at least 3 A (after a delay, the power switch can deliver 1.8 A continuous if  $V_P \leq 18$  V).

In a normal situation, the voltage on the reset delay capacitor is approximately 3.5 V (depending on the temperature). The power switch output is approximately  $V_P - 0.4$  V. At operating temperature, the power switch can deliver at least 3 A. At high temperature, the switch can deliver approximately 2 A.

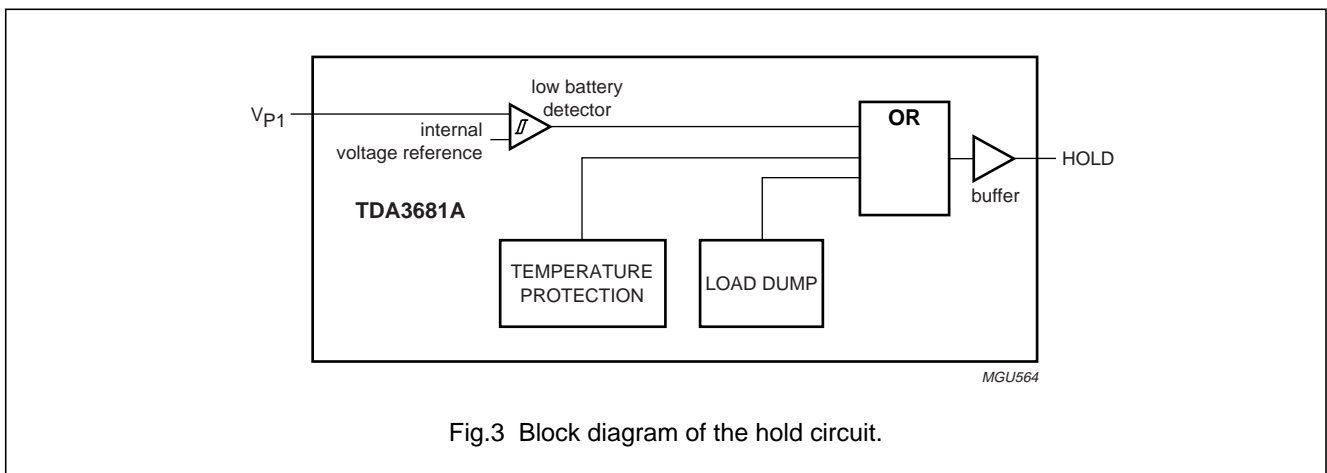

Fig.3 Block diagram of the hold circuit.

# Multiple voltage regulator with switch and ignition buffer

TDA3681A

During an overload condition or a short circuit ( $V_{SW} < V_P - 3.7 V$ ), the voltage on the reset delay capacitor rises 0.6 V above the voltage of regulator 2. This rise time depends on the capacitor connected to pin  $C_{CRES}$ . During this time, the power switch can deliver more than 3 A. When regulator 2 is out of regulation and generates a reset, the power switch can only deliver 2 A and will immediately go into foldback protection.

At supply voltages  $> 17 V$ , the power switch is clamped at 16 V maximum (to avoid externally connected circuits being damaged by an overvoltage) and the power switch will switch off at load dump.

Interfacing with the microcontroller (simple full or semi on/off logic applications) can be realized with an independent ignition Schmitt trigger and ignition output buffer (push-pull output).

The timing diagrams are illustrated in Figs 4 and 5.

The second supply voltage  $V_{P2}$  is used for the switchable regulators 3 and 4. This input can be connected to a lower supply voltage of  $\geq 6 V$  to reduce the power dissipation of the TDA3681A. A DC-to-DC converter could be used for this purpose.

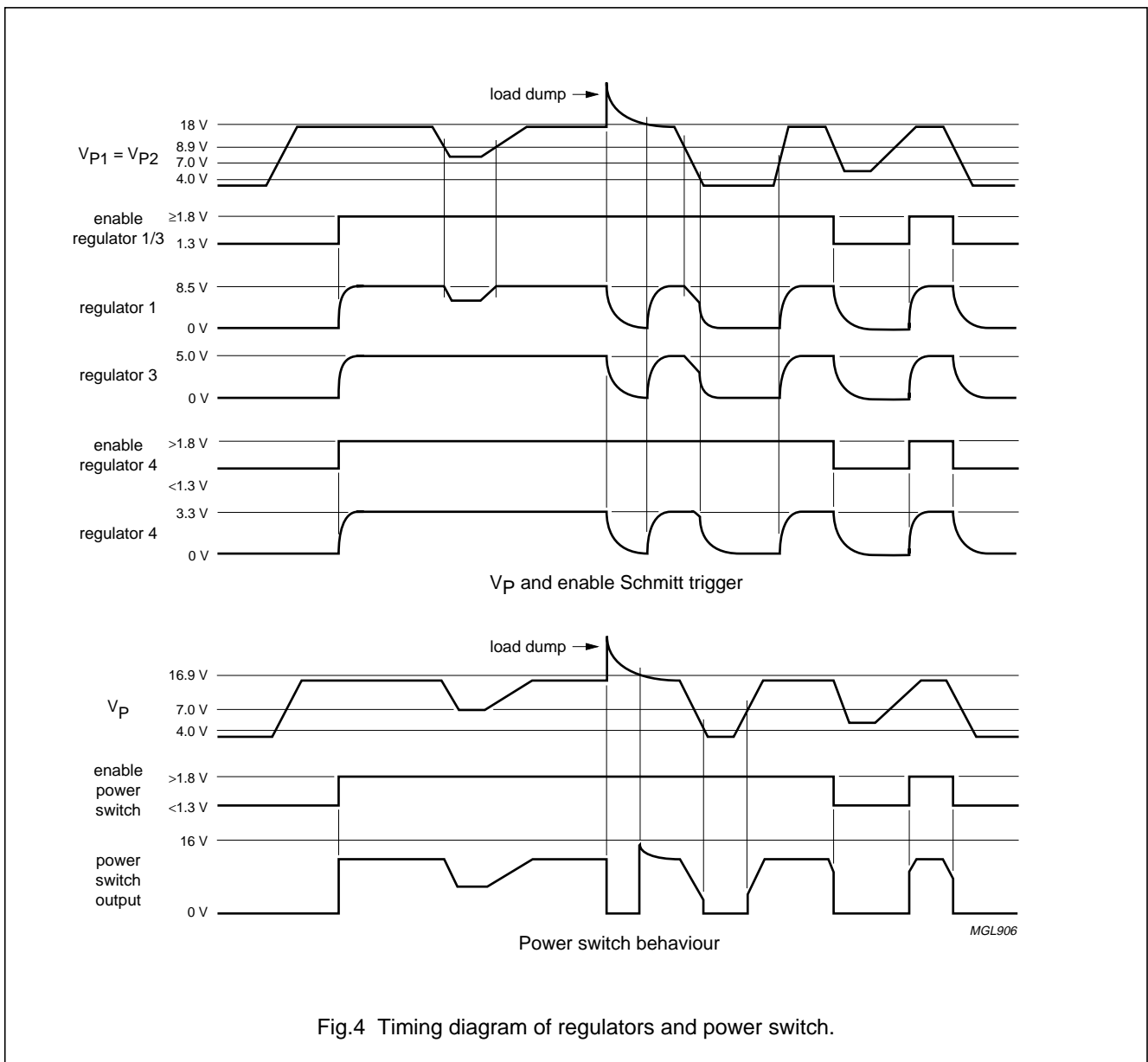
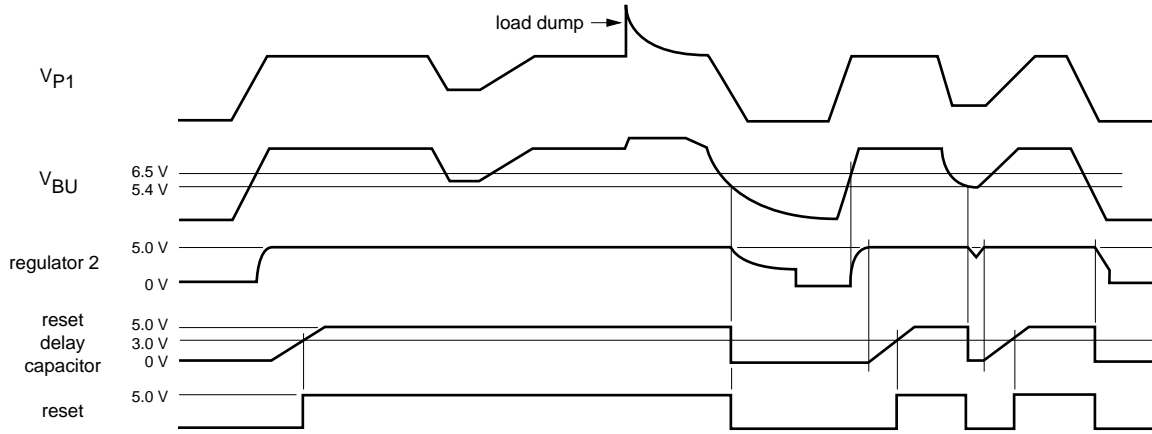

Fig.4 Timing diagram of regulators and power switch.

# Multiple voltage regulator with switch and ignition buffer

TDA3681A



Back-up Schmitt trigger and reset behaviour

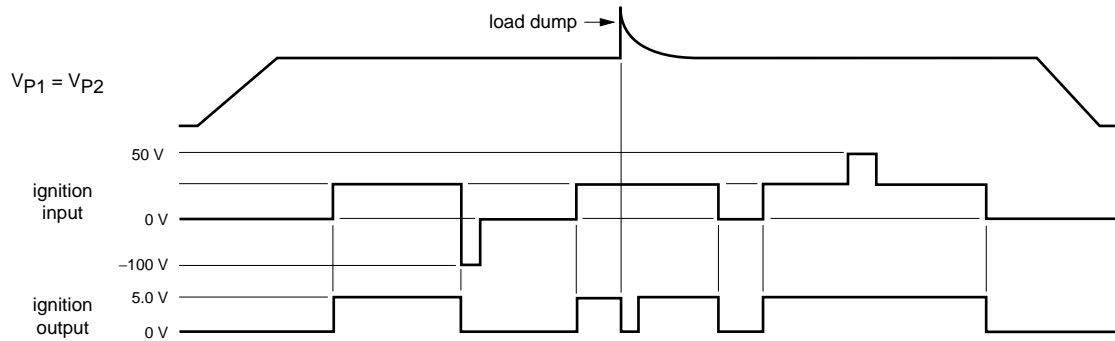

Enable Schmitt trigger ignition

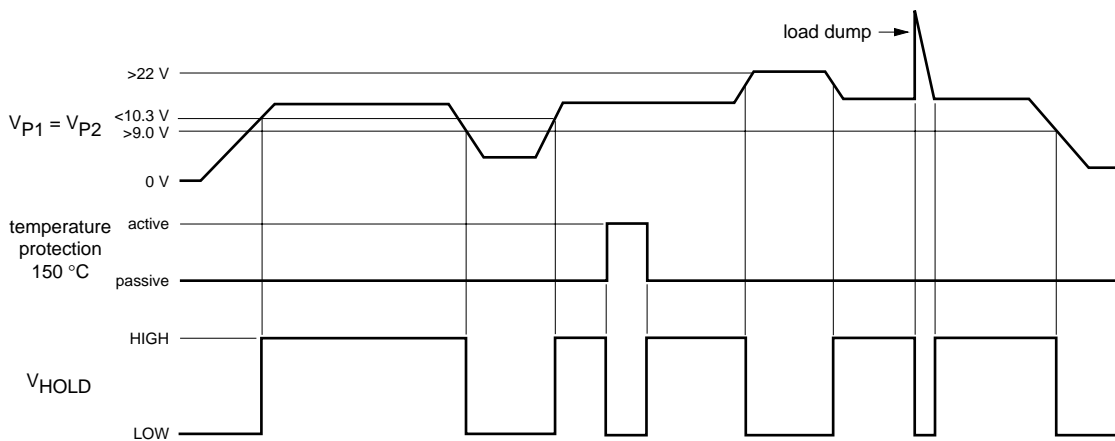

Hold behaviour

MGU565

Fig.5 Timing diagram of ignition Schmitt triggers and hold circuit.

# Multiple voltage regulator with switch and ignition buffer

TDA3681A

## LIMITING VALUES

In accordance with the Absolute Maximum Rating System (IEC 60134).

| SYMBOL           | PARAMETER                     | CONDITIONS                         | MIN. | MAX. | UNIT |
|------------------|-------------------------------|------------------------------------|------|------|------|
| V <sub>P1</sub>  | supply voltage 1<br>operating |                                    | –    | 18   | V    |
|                  | reverse polarity              | non-operating                      | –    | 18   | V    |
|                  | jump start                    | t ≤ 10 minutes                     | –    | 30   | V    |
|                  | load dump protection          | t ≤ 50 ms; t <sub>r</sub> ≥ 2.5 ms | –    | 50   | V    |
| V <sub>P2</sub>  | supply voltage 2<br>operating |                                    | –    | 18   | V    |
|                  | reverse polarity              | non-operating                      | –    | 18   | V    |
|                  | jump start                    | t ≤ 10 minutes                     | –    | 30   | V    |
|                  | load dump protection          | t ≤ 50 ms; t <sub>r</sub> ≥ 2.5 ms | –    | 50   | V    |
| P <sub>tot</sub> | total power dissipation       |                                    | –    | 62   | W    |
| T <sub>stg</sub> | storage temperature           | non-operating                      | –55  | +150 | °C   |
| T <sub>amb</sub> | ambient temperature           | operating                          | –40  | +85  | °C   |
| T <sub>j</sub>   | junction temperature          | operating                          | –40  | +150 | °C   |

## THERMAL CHARACTERISTICS

| SYMBOL               | PARAMETER                                   | CONDITIONS  | VALUE | UNIT |
|----------------------|---|-------------|-------|------|
| R <sub>th(j-c)</sub> | thermal resistance from junction to case    |             | 2     | K/W  |
| R <sub>th(j-a)</sub> | thermal resistance from junction to ambient | in free air | 50    | K/W  |

## QUALITY SPECIFICATION

In accordance with "General Quality Specification For Integrated Circuits (SNW-FQ-611)".

# Multiple voltage regulator with switch and ignition buffer

TDA3681A

## CHARACTERISTICS

$V_{P1} = V_{P2} = 14.4 \text{ V}$ ;  $T_{\text{amb}} = 25 \text{ °C}$ ; measured in test circuit of Fig.8; unless otherwise specified.

| SYMBOL  | PARAMETER                                      | CONDITIONS  | MIN. | TYP.                     | MAX.                     | UNIT          |
|---|--|---|------|--------------------------|--------------------------|---------------|
| <b>Supplies</b>   |  |   |      |                          |                          |               |
| $V_{P1}$  | supply voltage 1<br>operating                  |   | 9.5  | 14.4                     | 18                       | V             |
|   | reverse polarity                               | non-operating   | –    | –                        | 18                       | V             |
|   | regulator 2 on                                 | note 1  | 4    | 14.4                     | 50                       | V             |
|   | jump start                                     | $t \leq 10 \text{ minutes}$                                     | –    | –                        | 30                       | V             |
|   | load dump protection                           | $t \leq 50 \text{ ms}$ ; $t_r \geq 2.5 \text{ ms}$              | –    | –                        | 50                       | V             |
| $V_{P2}$  | supply voltage 2<br>operating                  |   | 6.5  | 14.4                     | 18                       | V             |
|   | reverse polarity                               | non-operating   | –    | –                        | 18                       | V             |
|   | regulator 2 on                                 |   | 0    | –                        | 50                       | V             |
|   | jump start                                     | $t \leq 10 \text{ minutes}$                                     | –    | –                        | 30                       | V             |
|   | load dump protection                           | $t \leq 50 \text{ ms}$ ; $t_r \geq 2.5 \text{ ms}$              | –    | –                        | 50                       | V             |
| $V_{\text{bat(loaddump)}}$  | battery overvoltage<br>shutdown                | $V_{P1}$ and/or $V_{P2}$  | 18   | 20                       | 22                       | V             |
| $I_{q(\text{tot})}$   | total quiescent supply<br>current              | $V_P = 12.4 \text{ V}$ ; note 2                                 | –    | 105                      | 145                      | $\mu\text{A}$ |
|   |  | $V_P = 14.4 \text{ V}$ ; note 2                                 | –    | 110                      | 150                      | $\mu\text{A}$ |
| <b>Schmitt trigger for power supply (regulators 1, 3 and 4)</b>               |  |   |      |                          |                          |               |
| $V_{\text{th}(r)}$  | rising threshold voltage                       | $V_{P1}$ rising   | 6.5  | 7.0                      | 7.5                      | V             |
| $V_{\text{th}(f)}$  | falling threshold voltage                      | $V_{P1}$ falling  | 4.0  | 4.5                      | 5.0                      | V             |
| $V_{\text{hys}}$  | hysteresis voltage                             |   | –    | 2.5                      | –                        | V             |
| <b>Schmitt trigger for enable input (regulators 1, 3, 4 and power switch)</b> |  |   |      |                          |                          |               |
| $V_{\text{th}(r)}$  | rising threshold voltage                       |   | 1.4  | 1.8                      | 2.4                      | V             |
| $V_{\text{th}(f)}$  | falling threshold voltage                      |   | 0.9  | 1.3                      | 1.9                      | V             |
| $V_{\text{hys}}$  | hysteresis voltage                             | $I_{\text{REG}} = I_{\text{SW}} = 1 \text{ mA}$                 | –    | 0.5                      | –                        | V             |
| $I_{\text{LI}}$   | input leakage current                          | $V_{\text{EN}} = 5 \text{ V}$                                   | 1    | 5                        | 20                       | $\mu\text{A}$ |
| <b>Reset trigger level of regulator 2</b>                                     |  |   |      |                          |                          |               |
| $V_{\text{th}(r)}$  | rising threshold voltage                       | $V_{P1}$ rising; $I_{\text{REG}1} = 50 \text{ mA}$ ;<br>note 3  | 4.43 | $V_{\text{REG}2} - 0.15$ | $V_{\text{REG}2} - 0.1$  | V             |
| $V_{\text{th}(f)}$  | falling threshold voltage                      | $V_{P1}$ falling; $I_{\text{REG}1} = 50 \text{ mA}$ ;<br>note 3 | 4.4  | $V_{\text{REG}2} - 0.25$ | $V_{\text{REG}2} - 0.13$ | V             |
| <b>Schmitt triggers for hold circuit output</b>                               |  |   |      |                          |                          |               |
| $V_{\text{th}(r)(\text{VP})}$   | rising threshold voltage<br>of supply voltage  |   | 9.1  | 9.7                      | 10.3                     | V             |
| $V_{\text{th}(f)(\text{VP})}$   | falling threshold voltage<br>of supply voltage |   | 9.0  | 9.4                      | 9.8                      | V             |
| $V_{\text{hys}(\text{VP})}$   | hysteresis voltage of<br>supply voltage        |   | –    | 0.3                      | –                        | V             |

Multiple voltage regulator with  
switch and ignition buffer

TDA3681A

| SYMBOL   | PARAMETER                               | CONDITIONS  | MIN. | TYP. | MAX. | UNIT          |
|--|---|---|------|------|------|---------------|
| <b>Reset and hold buffer</b>   |   |   |      |      |      |               |
| $I_{\text{sink(L)}}$   | LOW-level sink current                  | $V_{\text{RES}} \leq 0.8 \text{ V}; V_{\text{HOLD}} \leq 0.8 \text{ V}$                       | 2    | –    | –    | mA            |
| $I_{\text{LO}}$  | output leakage current                  | $V_{\text{HOLD}} = 5 \text{ V}$   | –    | 0.1  | 5    | $\mu\text{A}$ |
| $I_{\text{source(H)}}$   | HIGH-level source current               | $V_{\text{RES}} = 5 \text{ V}$  | 240  | 400  | 900  | $\mu\text{A}$ |
| $t_{\text{r}}$   | rise time                               | note 4  | –    | 7    | 50   | $\mu\text{s}$ |
| $t_{\text{f}}$   | fall time                               | note 4  | –    | 1    | 50   | $\mu\text{s}$ |
| <b>Reset delay</b>   |   |   |      |      |      |               |
| $I_{\text{ch}}$  | reset delay capacitor charge current    | $V_{\text{CRES}} = 0 \text{ V}$   | 2    | 4    | 8    | $\mu\text{A}$ |
| $I_{\text{dch}}$   | reset delay capacitor discharge current | $V_{\text{CRES}} = 3 \text{ V};$<br>$V_{\text{P1}} = V_{\text{P2}} = 4.3 \text{ V}$           | 1.0  | 1.6  | –    | mA            |
| $V_{\text{th(r)(RES)}}$  | rising voltage threshold reset signal   |   | 2.5  | 3.0  | 3.5  | V             |
| $V_{\text{th(f)(RES)}}$  | falling voltage threshold reset signal  |   | 1.0  | 1.2  | 1.4  | V             |
| $t_{\text{d(RES)}}$  | delay reset signal                      | $C_{\text{CRES}} = 47 \text{ nF};$ note 5   | 20   | 35   | 70   | ms            |
| $t_{\text{d(SW)}}$   | delay power switch foldback protection  | $C_{\text{CRES}} = 47 \text{ nF};$ note 6   | 8    | 17.6 | 40   | ms            |
| <b>Regulator 1 (<math>I_{\text{REG1}} = 5 \text{ mA}</math>; unless otherwise specified)</b> |   |   |      |      |      |               |
| $V_{\text{o(off)}}$  | output voltage off                      |   | –    | 1    | 400  | mV            |
| $V_{\text{o(REG1)}}$   | output voltage                          | $1 \text{ mA} \leq I_{\text{REG1}} \leq 600 \text{ mA}$                                       | 8.0  | 8.5  | 9.0  | V             |
|  |   | $9.5 \text{ V} \leq V_{\text{P1}} \leq 18 \text{ V}$  | 8.0  | 8.5  | 9.0  | V             |
| $\Delta V_{\text{line}}$   | line regulation                         | $9.5 \text{ V} \leq V_{\text{P1}} \leq 18 \text{ V}$  | –    | 2    | 75   | mV            |
| $\Delta V_{\text{load}}$   | load regulation                         | $1 \text{ mA} \leq I_{\text{REG1}} \leq 600 \text{ mA}$                                       | –    | 20   | 85   | mV            |
| $I_{\text{q}}$   | quiescent current                       | $I_{\text{REG1}} = 600 \text{ mA}$  | –    | 25   | 60   | mA            |
| SVRR   | supply voltage ripple rejection         | $f_{\text{i}} = 3 \text{ kHz}; V_{\text{i}} = 2 \text{ V (p-p)}$                              | 60   | 70   | –    | dB            |
| $V_{\text{drop(REG1)}}$  | drop-out voltage                        | $I_{\text{REG1}} = 550 \text{ mA};$<br>$V_{\text{P1}} = 8.55 \text{ V};$ note 7               | –    | 0.4  | 0.7  | V             |
| $I_{\text{m(REG1)}}$   | current limit                           | $V_{\text{REG1}} > 7 \text{ V};$ note 8   | 0.65 | 1.2  | –    | A             |
| $I_{\text{sc(REG1)}}$  | short-circuit current                   | $R_{\text{L}} \leq 0.5 \Omega;$ note 9  | 250  | 800  | –    | mA            |
| <b>Regulator 2 (<math>I_{\text{REG2}} = 5 \text{ mA}</math>; unless otherwise specified)</b> |   |   |      |      |      |               |
| $V_{\text{o(REG2)}}$   | output voltage                          | $0.5 \text{ mA} \leq I_{\text{REG2}} \leq 300 \text{ mA}$                                     | 4.75 | 5.0  | 5.25 | V             |
|  |   | $7 \text{ V} \leq V_{\text{P1}} \leq 18 \text{ V}$  | 4.75 | 5.0  | 5.25 | V             |
|  |   | $18 \text{ V} \leq V_{\text{P1}} \leq 50 \text{ V};$<br>$I_{\text{REG2}} \leq 150 \text{ mA}$ | 4.75 | 5.0  | 5.25 | V             |
| $\Delta V_{\text{line}}$   | line regulation                         | $6 \text{ V} \leq V_{\text{P1}} \leq 18 \text{ V}$  | –    | 2    | 50   | mV            |
|  |   | $6 \text{ V} \leq V_{\text{P1}} \leq 50 \text{ V}$  | –    | 15   | 75   | mV            |
| $\Delta V_{\text{load}}$   | load regulation                         | $1 \text{ mA} \leq I_{\text{REG2}} \leq 150 \text{ mA}$                                       | –    | 20   | 50   | mV            |
|  |   | $1 \text{ mA} \leq I_{\text{REG2}} \leq 300 \text{ mA}$                                       | –    | –    | 100  | mV            |

Multiple voltage regulator with  
switch and ignition buffer

TDA3681A

| SYMBOL  | PARAMETER                       | CONDITIONS   | MIN. | TYP. | MAX. | UNIT |
|---|---------------------------------|--|------|------|------|------|
| SVRR  | supply voltage ripple rejection | $f_i = 3 \text{ kHz}; V_i = 2 \text{ V (p-p)}$                                     | 50   | 55   | –    | dB   |
| $V_{\text{drop(REG2)}}$   | drop-out voltage                | $I_{\text{REG2}} = 100 \text{ mA}; V_{\text{P1}} = 4.75 \text{ V}; \text{note 7}$  | –    | 0.4  | 0.6  | V    |
|   |                                 | $I_{\text{REG2}} = 200 \text{ mA}; V_{\text{P1}} = 5.75 \text{ V}; \text{note 7}$  | –    | 0.8  | 1.2  | V    |
|   |                                 | $I_{\text{REG2}} = 100 \text{ mA}; V_{\text{BU}} = 4.75 \text{ V}; \text{note 10}$ | –    | 0.2  | 0.5  | V    |
|   |                                 | $I_{\text{REG2}} = 200 \text{ mA}; V_{\text{BU}} = 5.75 \text{ V}; \text{note 10}$ | –    | 0.8  | 1.0  | V    |
| $I_{\text{m(REG2)}}$  | current limit                   | $V_{\text{REG2}} > 4.5 \text{ V}; \text{note 8}$                                   | 0.32 | 0.37 | –    | A    |
| $I_{\text{sc(REG2)}}$   | short-circuit current           | $R_L \leq 0.5 \Omega; \text{note 9}$   | 95   | 120  | –    | mA   |
| <b>Regulator 3 (<math>I_{\text{REG3}} = 5 \text{ mA}; \text{unless otherwise specified}</math>)</b> |                                 |  |      |      |      |      |
| $V_{\text{o(off)}}$   | output voltage off              |  | –    | 1    | 400  | mV   |
| $V_{\text{o(REG3)}}$  | output voltage                  | $1 \text{ mA} \leq I_{\text{REG3}} \leq 1400 \text{ mA}$                           | 4.75 | 5.0  | 5.25 | V    |
|   |                                 | $7 \text{ V} \leq V_{\text{P1}} \text{ and/or } V_{\text{P2}} \leq 18 \text{ V}$   | 4.75 | 5.0  | 5.25 | V    |
| $\Delta V_{\text{line}}$  | line regulation                 | $7 \text{ V} \leq V_{\text{P1}} \text{ and/or } V_{\text{P2}} \leq 18 \text{ V}$   | –    | 2    | 50   | mV   |
| $\Delta V_{\text{load}}$  | load regulation                 | $1 \text{ mA} \leq I_{\text{REG3}} \leq 1400 \text{ mA}$                           | –    | 20   | 150  | mV   |
| $I_{\text{q}}$  | quiescent current               | $I_{\text{REG3}} = 1400 \text{ mA}$  | –    | 19   | 45   | mA   |
| SVRR  | supply voltage ripple rejection | $f_i = 3 \text{ kHz}; V_i = 2 \text{ V (p-p)}$                                     | 60   | 70   | –    | dB   |
| $V_{\text{drop(REG3)}}$   | drop-out voltage                | $I_{\text{REG3}} = 1400 \text{ mA}; V_{\text{P2}} = 6 \text{ V}; \text{note 7}$    | –    | 1    | 1.5  | V    |
| $I_{\text{m(REG3)}}$  | current limit                   | $V_{\text{REG3}} > 4.5 \text{ V}; \text{note 8}$                                   | 1.5  | 1.7  | –    | A    |
| $I_{\text{sc(REG3)}}$   | short-circuit current           | $R_L \leq 0.5 \Omega; \text{note 9}$   | 430  | 750  | –    | mA   |
| <b>Regulator 4 (<math>I_{\text{REG4}} = 5 \text{ mA}; \text{unless otherwise specified}</math>)</b> |                                 |  |      |      |      |      |
| $V_{\text{o(off)}}$   | output voltage off              |  | –    | 1    | 400  | mV   |
| $V_{\text{o(REG4)}}$  | output voltage                  | $1 \text{ mA} \leq I_{\text{REG4}} \leq 1 \text{ A}$                               | 3.14 | 3.3  | 3.46 | V    |
|   |                                 | $6.5 \text{ V} \leq V_{\text{P1}} \text{ and/or } V_{\text{P2}} \leq 18 \text{ V}$ | 3.14 | 3.3  | 3.46 | V    |
| $\Delta V_{\text{line}}$  | line regulation                 | $6.5 \text{ V} \leq V_{\text{P1}} \text{ and/or } V_{\text{P2}} \leq 18 \text{ V}$ | –    | 2    | 50   | mV   |
| $\Delta V_{\text{load}}$  | load regulation                 | $1 \text{ mA} \leq I_{\text{REG4}} \leq 1 \text{ A}$                               | –    | 20   | 50   | mV   |
| $I_{\text{q}}$  | quiescent current               | $I_{\text{REG4}} = 1 \text{ A}$  | –    | 15   | 40   | mA   |
| SVRR  | supply voltage ripple rejection | $f_i = 3 \text{ kHz}; V_i = 2 \text{ V (p-p)}$                                     | 60   | 70   | –    | dB   |
| $V_{\text{drop(REG4)}}$   | drop-out voltage                | $I_{\text{REG4}} = 1 \text{ A}; V_{\text{P2}} = 5 \text{ V}; \text{note 7}$        | –    | 1.7  | 2.4  | V    |
| $I_{\text{m(REG4)}}$  | current limit                   | $V_{\text{REG4}} > 3.0 \text{ V}; \text{note 8}$                                   | 1.1  | 1.5  | –    | A    |
| $I_{\text{sc(REG4)}}$   | short-circuit current           | $R_L \leq 0.5 \Omega; \text{note 9}$   | 470  | 750  | –    | mA   |

Multiple voltage regulator with  
switch and ignition buffer

TDA3681A

| SYMBOL  | PARAMETER                                   | CONDITIONS   | MIN.            | TYP.                | MAX. | UNIT          |
|---|---|--|-----------------|---------------------|------|---------------|
| <b>Power switch</b>                                 |   |  |                 |                     |      |               |
| $V_{\text{drop(SW)}}$                               | drop-out voltage                            | $I_{\text{SW}} = 1 \text{ A}; V_{\text{P1}} = 13.5 \text{ V};$<br>note 11            | –               | 0.45                | 0.65 | V             |
|   |   | $I_{\text{SW}} = 1.8 \text{ A}; V_{\text{P1}} = 13.5 \text{ V};$<br>note 11          | –               | 1.0                 | 1.8  | V             |
| $I_{\text{DC(SW)}}$                                 | continuous current                          | $V_{\text{P1}} = 16 \text{ V}; V_{\text{SW}} = 13.5 \text{ V}$                       | 1.8             | 2.0                 | –    | A             |
| $V_{\text{clamp(SW)}}$                              | clamping voltage                            | $V_{\text{P1}} \geq 17 \text{ V};$<br>$1 \text{ mA} < I_{\text{SW}} < 1.8 \text{ A}$ | 13.5            | 15.0                | 16.0 | V             |
| $I_{\text{M(SW)}}$                                  | peak current                                | $V_{\text{P1}} < 17 \text{ V};$<br>notes 6, 12 and 13                                | 3               | –                   | –    | A             |
| $V_{\text{fb(SW)}}$                                 | flyback voltage behaviour                   | $I_{\text{SW}} = -100 \text{ mA}$  | –               | $V_{\text{P1}} + 3$ | 22   | V             |
| $I_{\text{sc(SW)}}$                                 | short-circuit current                       | $V_{\text{SW}} < 1.2 \text{ V};$ note 13   | 0.5             | 1.7                 | –    | A             |
| <b>Backup switch</b>                                |   |  |                 |                     |      |               |
| $I_{\text{DC(BU)}}$                                 | continuous current                          | $V_{\text{BU}} > 5 \text{ V}$  | 0.3             | 0.35                | –    | A             |
| $V_{\text{clamp(BU)}}$                              | clamping voltage                            | $V_{\text{P1}} \geq 16.7 \text{ V}; I_{\text{REG2}} = 100 \text{ mA}$                | –               | –                   | 16   | V             |
| $I_{\text{r(BU)}}$                                  | reverse current                             | $V_{\text{P1}} = 0 \text{ V}; V_{\text{BU}} = 12.4 \text{ V}$                        | –               | –                   | 900  | $\mu\text{A}$ |
| <b>Schmitt trigger for enable of ignition input</b> |   |  |                 |                     |      |               |
| $V_{\text{th(r)(IGNIN)}}$                           | rising threshold voltage of ignition input  | $V_{\text{P1}} > 3.5 \text{ V}$  | 1.9             | 2.2                 | 2.5  | V             |
| $V_{\text{th(f)(IGNIN)}}$                           | falling threshold voltage of ignition input | $V_{\text{P1}} > 3.5 \text{ V}$  | 1.7             | 2.0                 | 2.3  | V             |
| $V_{\text{hys(IGNIN)}}$                             | hysteresis voltage                          | $V_{\text{P}} > 3.5 \text{ V}$   | 0.1             | 0.2                 | 0.5  | V             |
| $I_{\text{LI}}$                                     | input leakage current                       | $V_{\text{IGNIN}} = 5 \text{ V}$   | –               | –                   | 1.0  | $\mu\text{A}$ |
| $I_{\text{i(clamp)}}$                               | input clamp current                         | $V_{\text{IGNIN}} > 50 \text{ V}$  | –               | –                   | 50   | mA            |
| $V_{\text{IH(clamp)}}$                              | HIGH-level input clamping voltage           |  | $V_{\text{P1}}$ | –                   | 50   | V             |
| $V_{\text{IL(clamp)}}$                              | LOW-level input clamping voltage            |  | –0.6            | –                   | 0    | V             |
| <b>Ignition buffer</b>                              |   |  |                 |                     |      |               |
| $V_{\text{OL}}$                                     | LOW-level output voltage                    | $I_{\text{IGNOUT}} = 0 \text{ mA}$   | 0               | 0.2                 | 0.8  | V             |
| $V_{\text{OH}}$                                     | HIGH-level output voltage                   | $I_{\text{IGNOUT}} = 0 \text{ mA}$   | 4.5             | 5.0                 | 5.25 | V             |
| $I_{\text{OL}}$                                     | LOW-level output current                    | $V_{\text{IGNOUT}} \leq 0.8 \text{ V}$   | 0.45            | 0.8                 | –    | mA            |
| $I_{\text{OH}}$                                     | HIGH-level output current                   | $V_{\text{IGNOUT}} \geq 4.5 \text{ V}$   | –0.45           | –2.0                | –    | mA            |
| $I_{\text{LO}}$                                     | output leakage current (source)             | $V_{\text{IGNOUT}} = 5 \text{ V}; V_{\text{IGNIN}} = 0 \text{ V}$                    | –               | –                   | 1.0  | $\mu\text{A}$ |
| $t_{\text{PLH}}$                                    | LOW-to-HIGH propagation time                | $V_{\text{IGNIN}}$ rising from 1.7 to 2.5 V  | –               | –                   | 500  | $\mu\text{s}$ |
| $t_{\text{PHL}}$                                    | HIGH-to-LOW propagation time                | $V_{\text{IGNIN}}$ falling from 2.5 to 1.7 V   | –               | –                   | 500  | $\mu\text{s}$ |

# Multiple voltage regulator with switch and ignition buffer

TDA3681A

| SYMBOL                        | PARAMETER                             | CONDITIONS | MIN. | TYP. | MAX. | UNIT |
|-------------------------------|---------------------------------------|------------|------|------|------|------|
| <b>Temperature protection</b> |                                       |            |      |      |      |      |
| $T_{j(sd)}$                   | junction temperature for shutdown     |            | 150  | 160  | 170  | °C   |
| $T_{j(hold)}$                 | junction temperature for hold trigger |            | 150  | 160  | 170  | °C   |

**Notes**

- Minimum operating voltage, only if  $V_{P1}$  has exceeded 6.5 V.
- The total quiescent current is measured in the standby mode. Therefore, the enable inputs of regulators 1, 3, 4 and the power switch are grounded and  $R_{L(REG2)} = \infty$  (see Fig.8).
- The voltage of the regulator drops as a result of a  $V_{P1}$  drop for regulators 1 and 2. Regulators 3 and 4 drop as a result of  $V_{P2}$  drop.
- The rise and fall times are measured with a 10 k $\Omega$  pull-up resistor and a 50 pF load capacitor.
- The delay time depends on the value of the reset delay capacitor:  $t_{d(RES)} = \frac{C}{I_{ch}} \times V_{C(th)} = C \times (750 \times 10^3)[s]$
- The delay time depends on the value of the reset delay capacitor:  $t_{d(SW)} = \frac{C}{I_{ch}} \times V_{C(th)} = C \times (375 \times 10^3)[s]$
- The drop-out voltage of regulators 1 and 2 is measured between pins  $V_{P1}$  and REGn. The drop-out voltage of regulators 3 and 4 is measured between pins  $V_{P2}$  and REGn.
- At current limit,  $I_{m(REGn)}$  is held constant (see Fig.6).
- The foldback current protection limits the dissipated power at short-circuit (see Fig.6).
- The drop-out voltage is measured between pins BU and REG2.
- The drop-out voltage of the power switch is measured between pins  $V_{P1}$  and SW.
- The maximum output current of the power switch is limited to 1.8 A when the supply voltage exceeds 18 V.
- At short-circuit,  $I_{sc(SW)}$  of the power switch is held constant to a lower value than the continuous current after a delay of at least 10 ms (see Fig.7).

# Multiple voltage regulator with switch and ignition buffer

## TDA3681A

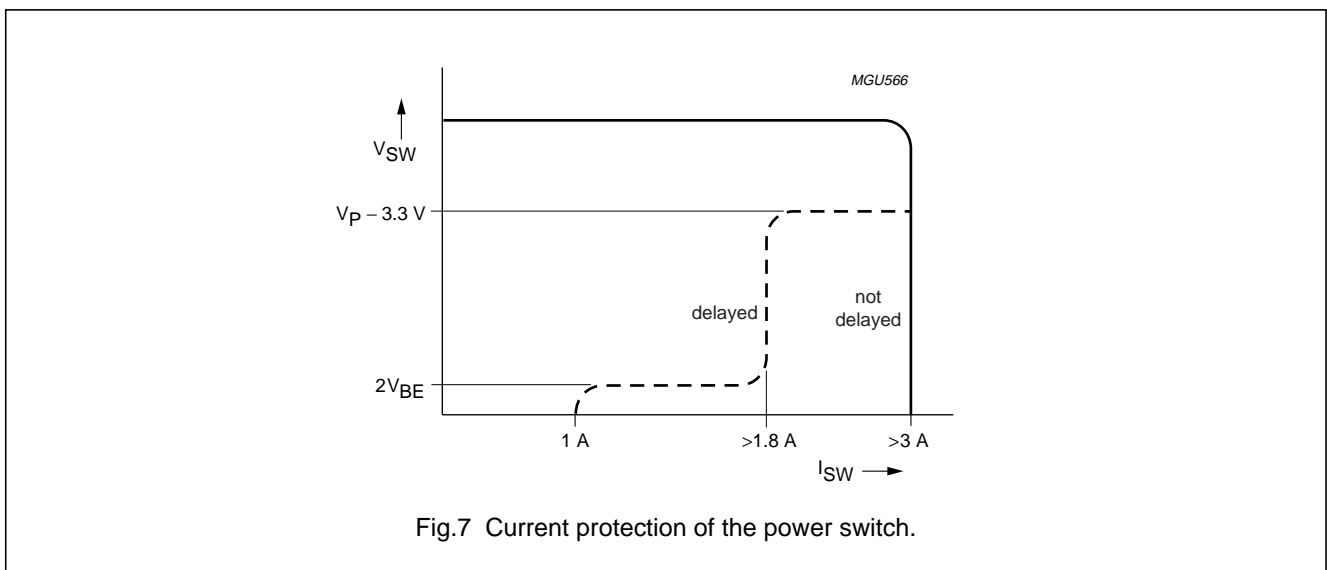
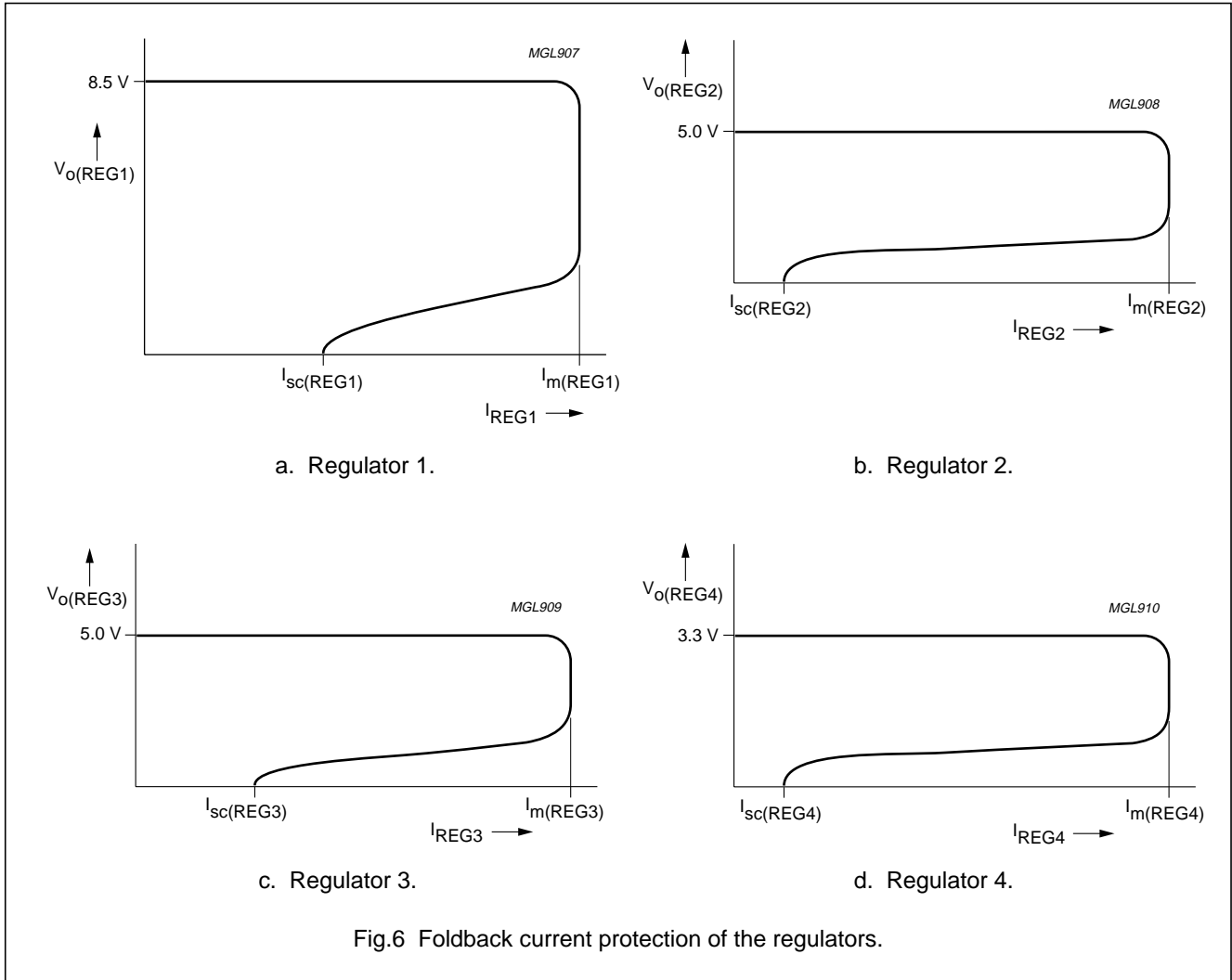

# Multiple voltage regulator with switch and ignition buffer

TDA3681A

## TEST AND APPLICATION INFORMATION

### Test information

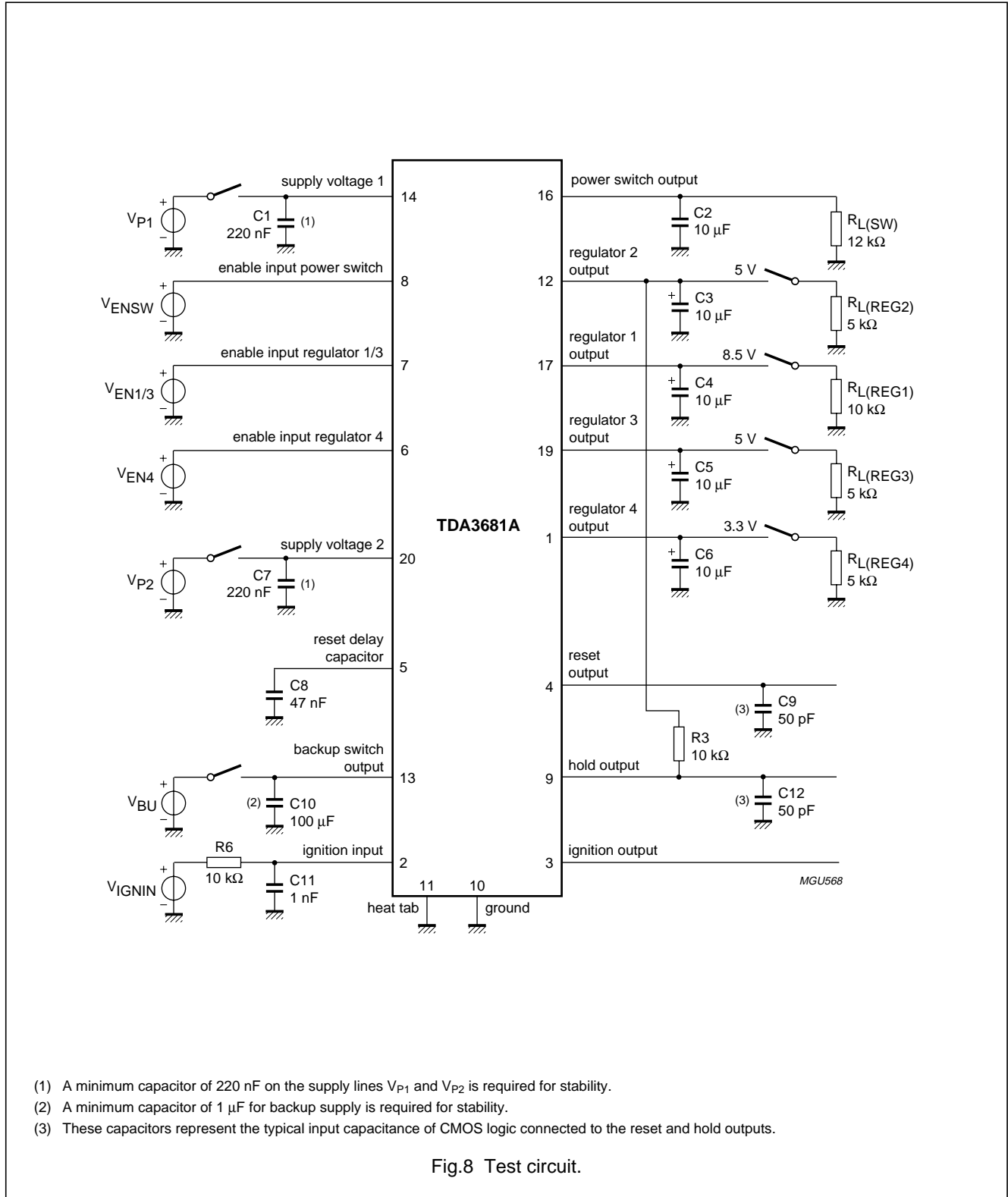

# Multiple voltage regulator with switch and ignition buffer

## TDA3681A

### Application information

#### NOISE

**Table 1** Noise figures

| REGULATOR | NOISE FIGURE ( $\mu\text{V}$ ) <sup>(1)</sup> |                        |                         |
|-----------|---|------------------------|-------------------------|
|           | $C_o = 10 \mu\text{F}$                        | $C_o = 47 \mu\text{F}$ | $C_o = 100 \mu\text{F}$ |
| 1         | 170   | 110                    | 110                     |
| 2         | 440   | 240                    | 190                     |
| 3         | 120   | 100                    | 80                      |
| 4         | 85  | 70                     | 55                      |

#### Note

1. Measured at a bandwidth of 30 kHz.

The noise on the supply line depends on the value of the supply capacitor and is caused by a current noise (the output noise of the regulators is translated to a current noise by the output capacitors). The noise is minimal when a high frequency capacitor of 220 nF in parallel with an electrolytic capacitor of 100  $\mu\text{F}$  is connected directly to the supply pins  $V_{P1}$ ,  $V_{P2}$  and GND.

#### STABILITY

The regulators are stabilized by the externally connected output capacitors.

The output capacitors can be selected by using the graphs given in Figs 9 and 10. When an electrolytic capacitor is used, its temperature behaviour can cause oscillations at a low temperature. The two examples below show how an output capacitor value is selected.

#### Example 1

Regulators 1, 3 and 4 are stabilized with an electrolytic output capacitor of 220  $\mu\text{F}$  (ESR = 0.15  $\Omega$ ).

At  $T_{\text{amb}} = -30 \text{ }^\circ\text{C}$ , the capacitor value is decreased to 73  $\mu\text{F}$  and the ESR is increased to 1.1  $\Omega$ . The regulator remains stable at  $T_{\text{amb}} = -30 \text{ }^\circ\text{C}$  (see Fig.9).

#### Example 2

Regulator 2 is stabilized with a 10  $\mu\text{F}$  electrolytic capacitor (ESR = 3  $\Omega$ ). At  $T_{\text{amb}} = -30 \text{ }^\circ\text{C}$ , the capacitor value is decreased to 3  $\mu\text{F}$  and the ESR is increased to 23.1  $\Omega$ .

As can be seen from Fig.10, the regulator will be unstable at  $T_{\text{amb}} = -30 \text{ }^\circ\text{C}$ .

#### Solution

To avoid problems with stability at low temperatures, the use of tantalum capacitors is recommended. Use a tantalum capacitor of 10  $\mu\text{F}$  or a larger electrolytic capacitor.

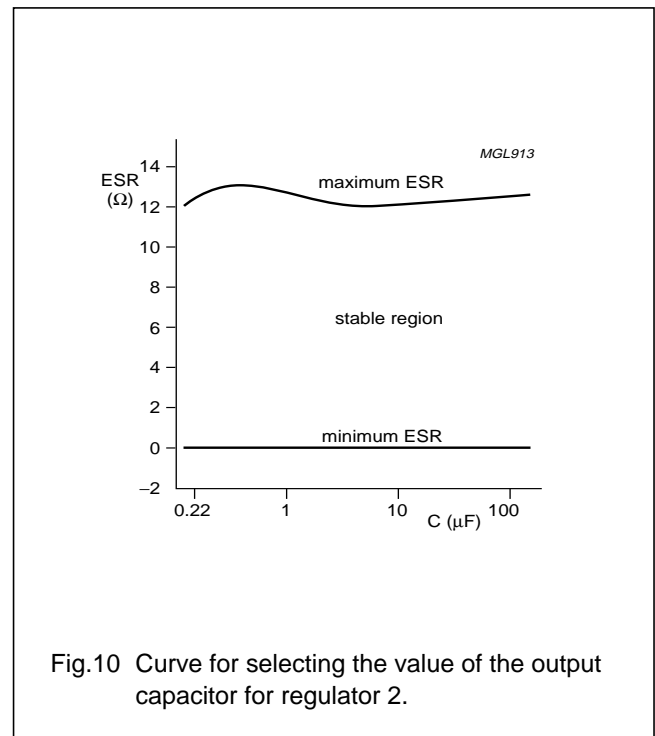
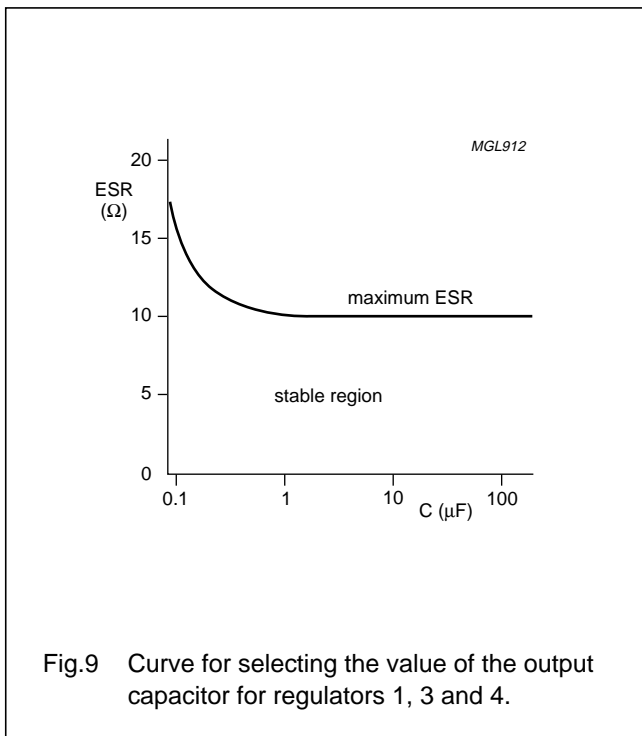

# Multiple voltage regulator with switch and ignition buffer

TDA3681A

## PACKAGE OUTLINE

HSOP20: plastic, heatsink small outline package; 20 leads; low stand-off height

SOT418-3

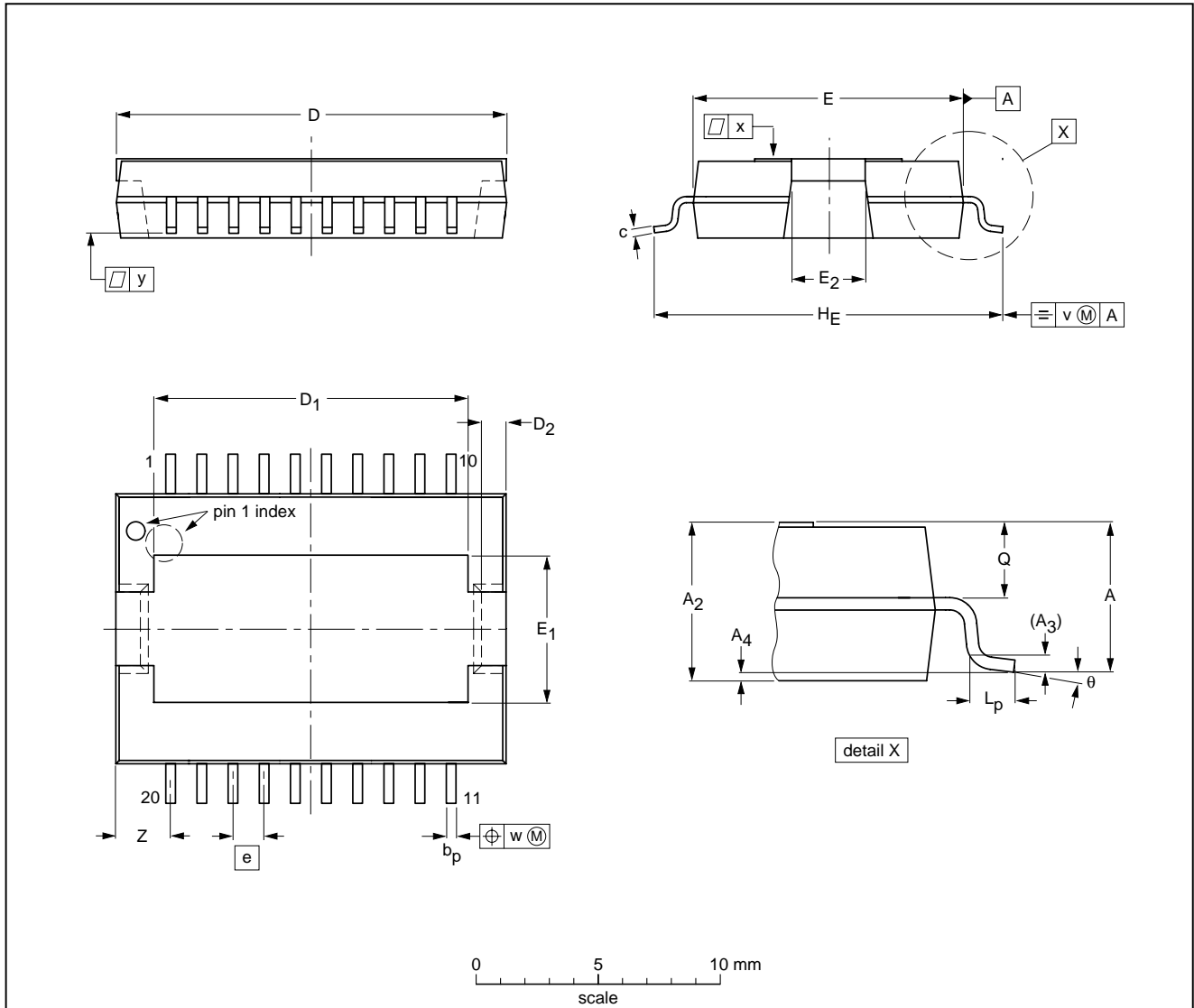

**DIMENSIONS (mm are the original dimensions)**

| UNIT | A <sub>max.</sub> | A <sub>2</sub> | A <sub>3</sub> | A <sub>4</sub> <sup>(1)</sup> | b <sub>p</sub> | c            | D <sup>(2)</sup> | D <sub>1</sub> | D <sub>2</sub> | E <sup>(2)</sup> | E <sub>1</sub> | E <sub>2</sub> | e    | H <sub>E</sub> | L <sub>p</sub> | Q          | v    | w    | x    | y    | Z          | θ        |
|------|-------------------|----------------|----------------|-------------------------------|----------------|--------------|------------------|----------------|----------------|------------------|----------------|----------------|------|----------------|----------------|------------|------|------|------|------|------------|----------|
| mm   | 3.5               | 3.5<br>3.2     | 0.35           | +0.08<br>-0.04                | 0.53<br>0.40   | 0.32<br>0.23 | 16.0<br>15.8     | 13.0<br>12.6   | 1.1<br>0.9     | 11.1<br>10.9     | 6.2<br>5.8     | 2.9<br>2.5     | 1.27 | 14.5<br>13.9   | 1.1<br>0.8     | 1.7<br>1.5 | 0.25 | 0.25 | 0.03 | 0.07 | 2.5<br>2.0 | 8°<br>0° |

**Notes**

- Limits per individual lead.
- Plastic or metal protrusions of 0.25 mm maximum per side are not included.

| OUTLINE VERSION | REFERENCES |       |       |  | EUROPEAN PROJECTION | ISSUE DATE           |
|-----------------|------------|-------|-------|--|---------------------|----------------------|
|                 | IEC        | JEDEC | JEITA |  |                     |                      |
| SOT418-3        |            |       |       |  |                     | 02-02-12<br>03-07-23 |

## Multiple voltage regulator with switch and ignition buffer

TDA3681A

### SOLDERING

#### Introduction to soldering surface mount packages

This text gives a very brief insight to a complex technology. A more in-depth account of soldering ICs can be found in our "Data Handbook IC26; Integrated Circuit Packages" (document order number 9398 652 90011).

There is no soldering method that is ideal for all surface mount IC packages. Wave soldering can still be used for certain surface mount ICs, but it is not suitable for fine pitch SMDs. In these situations reflow soldering is recommended.

#### Reflow soldering

Reflow soldering requires solder paste (a suspension of fine solder particles, flux and binding agent) to be applied to the printed-circuit board by screen printing, stencilling or pressure-syringe dispensing before package placement. Driven by legislation and environmental forces the worldwide use of lead-free solder pastes is increasing.

Several methods exist for reflowing; for example, convection or convection/infrared heating in a conveyor type oven. Throughput times (preheating, soldering and cooling) vary between 100 and 200 seconds depending on heating method.

Typical reflow peak temperatures range from 215 to 270 °C depending on solder paste material. The top-surface temperature of the packages should preferably be kept:

- below 220 °C (SnPb process) or below 245 °C (Pb-free process)
  - for all BGA and SSOP-T packages
  - for packages with a thickness  $\geq 2.5$  mm
  - for packages with a thickness  $< 2.5$  mm and a volume  $\geq 350$  mm<sup>3</sup> so called thick/large packages.
- below 235 °C (SnPb process) or below 260 °C (Pb-free process) for packages with a thickness  $< 2.5$  mm and a volume  $< 350$  mm<sup>3</sup> so called small/thin packages.

Moisture sensitivity precautions, as indicated on packing, must be respected at all times.

#### Wave soldering

Conventional single wave soldering is not recommended for surface mount devices (SMDs) or printed-circuit boards with a high component density, as solder bridging and non-wetting can present major problems.

To overcome these problems the double-wave soldering method was specifically developed.

If wave soldering is used the following conditions must be observed for optimal results:

- Use a double-wave soldering method comprising a turbulent wave with high upward pressure followed by a smooth laminar wave.
- For packages with leads on two sides and a pitch (e):
  - larger than or equal to 1.27 mm, the footprint longitudinal axis is **preferred** to be parallel to the transport direction of the printed-circuit board;
  - smaller than 1.27 mm, the footprint longitudinal axis **must** be parallel to the transport direction of the printed-circuit board.

The footprint must incorporate solder thieves at the downstream end.

- For packages with leads on four sides, the footprint must be placed at a 45° angle to the transport direction of the printed-circuit board. The footprint must incorporate solder thieves downstream and at the side corners.

During placement and before soldering, the package must be fixed with a droplet of adhesive. The adhesive can be applied by screen printing, pin transfer or syringe dispensing. The package can be soldered after the adhesive is cured.

Typical dwell time of the leads in the wave ranges from 3 to 4 seconds at 250 °C or 265 °C, depending on solder material applied, SnPb or Pb-free respectively.

A mildly-activated flux will eliminate the need for removal of corrosive residues in most applications.

#### Manual soldering

Fix the component by first soldering two diagonally-opposite end leads. Use a low voltage (24 V or less) soldering iron applied to the flat part of the lead. Contact time must be limited to 10 seconds at up to 300 °C.

When using a dedicated tool, all other leads can be soldered in one operation within 2 to 5 seconds between 270 and 320 °C.

# Multiple voltage regulator with switch and ignition buffer

TDA3681A

## Suitability of surface mount IC packages for wave and reflow soldering methods

| PACKAGE <sup>(1)</sup>   | SOLDERING METHOD                  |                       |
|--|-----------------------------------|-----------------------|
|  | WAVE                              | REFLOW <sup>(2)</sup> |
| BGA, LBGA, LFBGA, SQFP, SSOP-T <sup>(3)</sup> , TFBGA, VFBGA             | not suitable                      | suitable              |
| DHVQFN, HBCC, HBGA, HLQFP, HSQFP, HSOP, HTQFP, HTSSOP, HVQFN, HVSON, SMS | not suitable <sup>(4)</sup>       | suitable              |
| PLCC <sup>(5)</sup> , SO, SOJ  | suitable                          | suitable              |
| LQFP, QFP, TQFP  | not recommended <sup>(5)(6)</sup> | suitable              |
| SSOP, TSSOP, VSO, VSSOP  | not recommended <sup>(7)</sup>    | suitable              |
| PMFP <sup>(8)</sup>  | not suitable                      | not suitable          |

### Notes

- For more detailed information on the BGA packages refer to the “(LF)BGA Application Note” (AN01026); order a copy from your Philips Semiconductors sales office.
- All surface mount (SMD) packages are moisture sensitive. Depending upon the moisture content, the maximum temperature (with respect to time) and body size of the package, there is a risk that internal or external package cracks may occur due to vaporization of the moisture in them (the so called popcorn effect). For details, refer to the Drypack information in the “Data Handbook IC26; Integrated Circuit Packages; Section: Packing Methods”.
- These transparent plastic packages are extremely sensitive to reflow soldering conditions and must on no account be processed through more than one soldering cycle or subjected to infrared reflow soldering with peak temperature exceeding  $217\text{ °C} \pm 10\text{ °C}$  measured in the atmosphere of the reflow oven. The package body peak temperature must be kept as low as possible.
- These packages are not suitable for wave soldering. On versions with the heatsink on the bottom side, the solder cannot penetrate between the printed-circuit board and the heatsink. On versions with the heatsink on the top side, the solder might be deposited on the heatsink surface.
- If wave soldering is considered, then the package must be placed at a  $45^\circ$  angle to the solder wave direction. The package footprint must incorporate solder thieves downstream and at the side corners.
- Wave soldering is suitable for LQFP, TQFP and QFP packages with a pitch (e) larger than 0.8 mm; it is definitely not suitable for packages with a pitch (e) equal to or smaller than 0.65 mm.
- Wave soldering is suitable for SSOP, TSSOP, VSO and VSSOP packages with a pitch (e) equal to or larger than 0.65 mm; it is definitely not suitable for packages with a pitch (e) equal to or smaller than 0.5 mm.
- Hot bar or manual soldering is suitable for PMFP packages.

# Multiple voltage regulator with switch and ignition buffer

TDA3681A

## DATA SHEET STATUS

| LEVEL | DATA SHEET STATUS <sup>(1)</sup> | PRODUCT STATUS <sup>(2)(3)</sup> | DEFINITION   |
|-------|----------------------------------|----------------------------------|--|
| I     | Objective data                   | Development                      | This data sheet contains data from the objective specification for product development. Philips Semiconductors reserves the right to change the specification in any manner without notice.  |
| II    | Preliminary data                 | Qualification                    | This data sheet contains data from the preliminary specification. Supplementary data will be published at a later date. Philips Semiconductors reserves the right to change the specification without notice, in order to improve the design and supply the best possible product.             |
| III   | Product data                     | Production                       | This data sheet contains data from the product specification. Philips Semiconductors reserves the right to make changes at any time in order to improve the design, manufacturing and supply. Relevant changes will be communicated via a Customer Product/Process Change Notification (CPCN). |

### Notes

1. Please consult the most recently issued data sheet before initiating or completing a design.
2. The product status of the device(s) described in this data sheet may have changed since this data sheet was published. The latest information is available on the Internet at URL <http://www.semiconductors.philips.com>.
3. For data sheets describing multiple type numbers, the highest-level product status determines the data sheet status.

### DEFINITIONS

**Short-form specification** — The data in a short-form specification is extracted from a full data sheet with the same type number and title. For detailed information see the relevant data sheet or data handbook.

**Limiting values definition** — Limiting values given are in accordance with the Absolute Maximum Rating System (IEC 60134). Stress above one or more of the limiting values may cause permanent damage to the device. These are stress ratings only and operation of the device at these or at any other conditions above those given in the Characteristics sections of the specification is not implied. Exposure to limiting values for extended periods may affect device reliability.

**Application information** — Applications that are described herein for any of these products are for illustrative purposes only. Philips Semiconductors make no representation or warranty that such applications will be suitable for the specified use without further testing or modification.

### DISCLAIMERS

**Life support applications** — These products are not designed for use in life support appliances, devices, or systems where malfunction of these products can reasonably be expected to result in personal injury. Philips Semiconductors customers using or selling these products for use in such applications do so at their own risk and agree to fully indemnify Philips Semiconductors for any damages resulting from such application.

**Right to make changes** — Philips Semiconductors reserves the right to make changes in the products - including circuits, standard cells, and/or software - described or contained herein in order to improve design and/or performance. When the product is in full production (status 'Production'), relevant changes will be communicated via a Customer Product/Process Change Notification (CPCN). Philips Semiconductors assumes no responsibility or liability for the use of any of these products, conveys no licence or title under any patent, copyright, or mask work right to these products, and makes no representations or warranties that these products are free from patent, copyright, or mask work right infringement, unless otherwise specified.

# ***Philips Semiconductors – a worldwide company***

## **Contact information**

For additional information please visit <http://www.semiconductors.philips.com>. Fax: +31 40 27 24825

For sales offices addresses send e-mail to: [sales.addresses@www.semiconductors.philips.com](mailto:sales.addresses@www.semiconductors.philips.com).

© Koninklijke Philips Electronics N.V. 2003

SCA75

All rights are reserved. Reproduction in whole or in part is prohibited without the prior written consent of the copyright owner.

The information presented in this document does not form part of any quotation or contract, is believed to be accurate and reliable and may be changed without notice. No liability will be accepted by the publisher for any consequence of its use. Publication thereof does not convey nor imply any license under patent- or other industrial or intellectual property rights.

Printed in The Netherlands

R32/02/pp22

Date of release: 2003 Aug 29

Document order number: 9397 750 11719

*Let's make things better.*

**Philips  
Semiconductors**



**PHILIPS**

## Looking for pricing, stock, or lifecycle information?

Click below to explore more details on WIN SOURCE:

- ⊖ [View TDA3681ATH/N1S on WIN SOURCE](#)
- ⊖ [NXP / Nexperia Information](#)

## Optimize Your Supply Chain with WIN SOURCE Solutions

- ✓ Global Sourcing Solution
- ✓ Obsolete Management
- ✓ Cost Control Management
- ✓ Shortage Management
- ✓ Alternative Solution
- ✓ Excess Inventory Management