



THE DATASHEET OF TDA21220



ACNW3190

5.0 Amp High Output Current IGBT Gate Drive Optocoupler



Data Sheet



Lead (Pb) Free
RoHS 6 fully compliant

RoHS 6 fully compliant options available;
-xxxE denotes a lead-free product

Description

The ACNW3190 contains an AlGaAs LED, which is optically coupled to an integrated circuit with a power output stage. This optocoupler is ideally suited for driving power IGBTs and MOSFETs used in motor control inverter applications. The high operating voltage range of the output stage provides the drive voltages required by gate controlled devices. The voltage and high peak output current supplied by this optocoupler make it ideally suited for direct driving IGBTs with ratings up to 1200V/200 A, 600 V/300 A. For IGBTs with higher ratings, the ACNW3190 can be used to drive a discrete power stage which drives the IGBT gate. The ACNW3190 has the highest insulation voltage of $V_{IORM}=1414 V_{peak}$ in the IEC/ EN/DIN EN 60747-5-5.

Functional Diagram

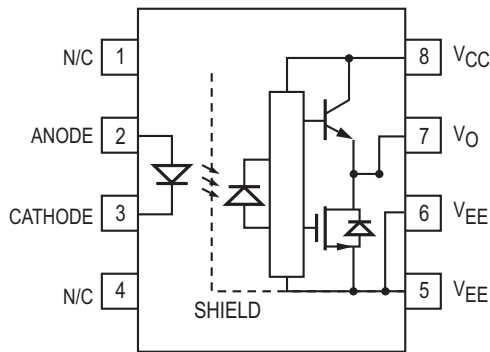

TRUTH TABLE

LED	$V_{CC} - V_{EE}$ "POSITIVE GOING" (i.e., TURN-ON)	$V_{CC} - V_{EE}$ "NEGATIVE GOING" (i.e., TURN-OFF)	V_O
OFF	0 - 30 V	0 - 30 V	LOW
ON	0 - 11 V	0 - 9.5 V	LOW
ON	11 - 13.5 V	9.5 - 12 V	TRANSITION
ON	13.5 - 30 V	12 - 30 V	HIGH

A 0.1 μF bypass capacitor must be connected between pins 5 and 8.

Features

- 5.0 A Maximum Peak Output Current
- 15 kV/ μs Minimum Common Mode Rejection (CMR) at $V_{CM} = 1500 V$
- 0.5 V Maximum Low Level Output Voltage (V_{OL}) Eliminates Need for Negative Gate Drive
- $I_{CC} = 5 mA$ Maximum Supply Current
- Under Voltage Lock-Out Protection (UVLO) with Hysteresis
- Wide Operating V_{CC} Range: 15 to 30 Volts
- 500 ns Maximum Switching Speeds
- Industrial Temperature Range: $-40^{\circ}C$ to $100^{\circ}C$
- Safety Approval

UL Recognized

5000 V_{rms} for 1 min.

CSA Approval

IEC/EN/DIN EN 60747-5-5 Approved

$V_{IORM} = 1414 V_{peak}$

Applications

- IGBT/MOSFET Gate Drive
- AC/Brushless DC Motor Drives
- Industrial Inverters
- Switch Mode Power Supplies

CAUTION: It is advised that normal static precautions be taken in handling and assembly of this component to prevent damage and/or degradation which may be induced by ESD.

Ordering Information

ACNW3190 is UL Recognized with 5000Vrms for 1 minute per UL1577.

Part number	Option		Surface Mount	Gull Wing	Tape & Reel	IEC/EN/DIN EN 60747-5-5	Quantity
	RoHS Compliant	Package					
ACNW3190	-000E	400mil DIP-8				X	42 per tube
	-300E		X	X		X	42 per tube
	-500E		X	X	X	X	750 per reel

To order, choose a part number from the part number column and combine with the desired option from the option column to form an order entry.

Example 1:

ACNW3190-500E to order product of 400mil DIP Gull Wing Surface Mount package in Tape and Reel packaging with IEC/EN/DIN EN 60747-5-5 Safety Approval in RoHS compliant.

Example 2:

ACNW3190-000E to order product of 400mil DIP package in tube packaging and RoHS compliant.

Option datasheets are available. Contact your Avago sales representative or authorized distributor for information.

Package Outline Drawings

ACNW3190 Outline Drawing (8-pin Wide Body Package)

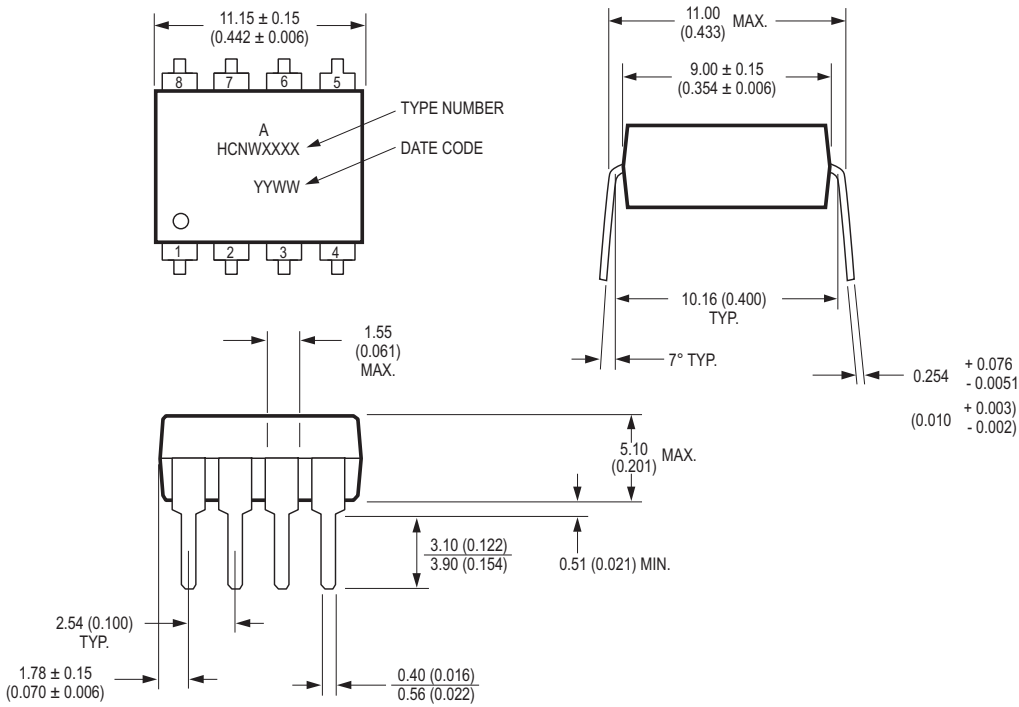

ACNW3190 Gull Wing Surface Mount Option 300 Outline Drawing

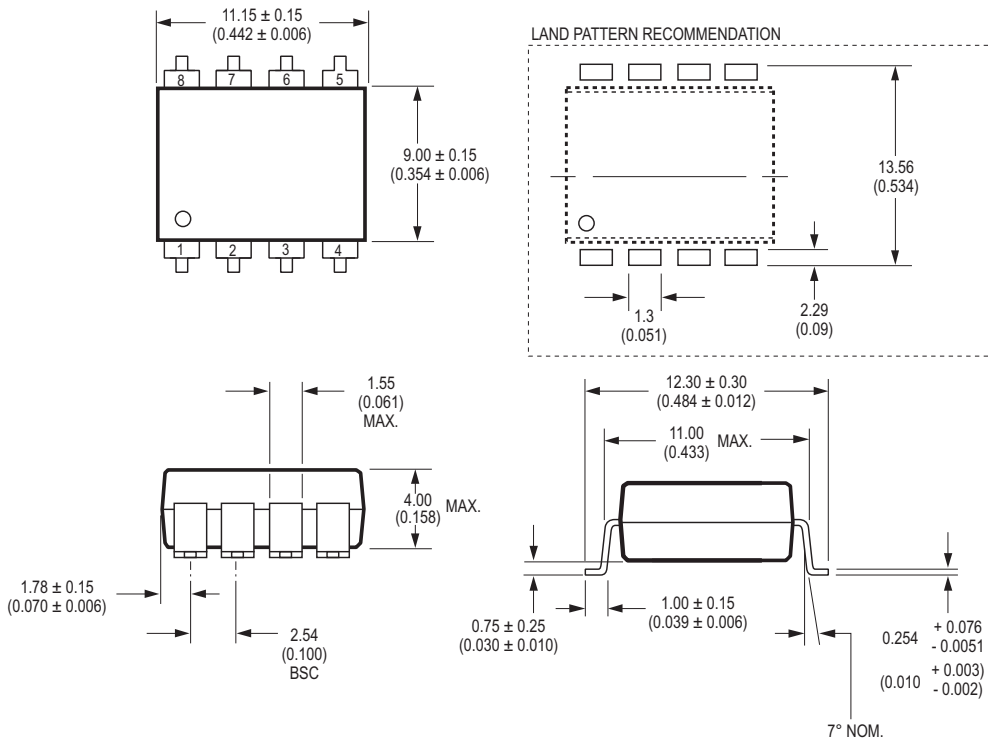

Dimensions in inches (millimeters)

Note:
Floating Lead Protrusion is 0.25 mm (10 mils) max.

Recommended Pb-Free IR Profile

Recommended reflow condition as per JEDEC Standard, J-STD-020 (latest revision). Non-Halide Flux should be used.

Dependence of Safety Limiting Values on Temperature

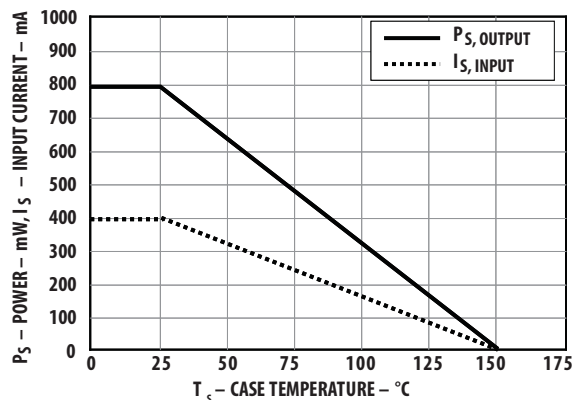

Note:

The Thermal Derating Graph above is in relation to Figure 30 and Figure 31 and S = 2cm.

Regulatory Information

The ACNW3190 is approved by the following organizations:

IEC/EN/DIN EN 60747-5-5

Maximum Working Insulation Voltage $V_{IORM} = 1414V_{PEAK}$

UL

Approval under UL 1577, component recognition program up to $V_{ISO} = 5000 V_{RMS}$ expected prior to product release. File E55361.

CSA

Approval under CSA Component Acceptance Notice #5, File CA 88324 expected prior to product release.

Table 1. IEC/EN/DIN EN 60747-5-5 Insulation Characteristics*

Description	Symbol	Characteristic	Unit
Installation classification per DIN VDE 0110/1.89, Table 1			
for rated mains voltage $\leq 150 V_{rms}$		I – IV	
for rated mains voltage $\leq 300 V_{rms}$		I – IV	
for rated mains voltage $\leq 450 V_{rms}$		I – IV	
for rated mains voltage $\leq 600 V_{rms}$		I – IV	
for rated mains voltage $\leq 1000 V_{rms}$		I – III	
Climatic Classification		55/100/21	
Pollution Degree (DIN VDE 0110/1.89)		2	
Maximum Working Insulation Voltage	V_{IORM}	1414	V_{peak}
Input to Output Test Voltage, Method b**			
$V_{IORM} \times 1.875 = V_{PR}$, 100% Production Test with $t_m = 1$ sec, Partial discharge < 5 pC	V_{PR}	2652	V_{peak}
Input to Output Test Voltage, Method a**			
$V_{IORM} \times 1.6 = V_{PR}$, Type and Sample Test, $t_m = 10$ sec, Partial discharge < 5 pC	V_{PR}	2262	V_{peak}
Highest Allowable Overvoltage (Transient Overvoltage $t_{ini} = 60$ sec)	V_{IOTM}	8000	V_{peak}
Safety-limiting values			
– maximum values allowed in the event of a failure, also see Figure 2.			
Case Temperature	T_S	150	°C
Input Current	$I_{S, INPUT}$	400	mA
Output Power	$P_{S, OUTPUT}$	800	mW
Insulation Resistance at $T_S, V_{IO} = 500$ V	R_S	$\geq 10^9$	Ω

* Isolation characteristics are guaranteed only within the safety maximum ratings which must be ensured by protective circuits in application. Surface mount classification is class A in accordance with CECCO0802.

** Refer to the optocoupler section of the Isolation and Control Components Designer's Catalog, under Product Safety Regulations section IEC/EN/DIN EN 60747-5-5, for a detailed description of Method a and Method b partial discharge test profiles.

Table 2. Insulation and Safety Related Specifications

Parameter	Symbol	ACNW3190	Units	Conditions
Minimum External Air Gap (Clearance)	L(101)	9.6	mm	Measured from input terminals to output terminals, shortest distance through air.
Minimum External Tracking (Creepage)	L(102)	10.0	mm	Measured from input terminals to output terminals, shortest distance path along body.
Minimum Internal Plastic Gap (Internal Clearance)		1.0	mm	Through insulation distance conductor to conductor, usually the straight line distance thickness between the emitter and detector.
Tracking Resistance (Comparative Tracking Index)	CTI	>200	V	DIN IEC 112/VDE 0303 Part 1
Isolation Group		IIIa		Material Group (DIN VDE 0110, 1/89, Table 1)

Notes:

All Avago data sheets report the creepage and clearance inherent to the optocoupler component itself. These dimensions are needed as a starting point for the equipment designer when determining the circuit insulation requirements. However, once mounted on a printed circuit board, minimum creepage and clearance requirements must be met as specified for individual equipment standards. For creepage, the shortest distance path along the surface of a printed circuit board between the solder fillets of the input and output leads must be considered (the recommended Land Pattern does not necessarily meet the minimum creepage of the device). There are recommended techniques such as grooves and ribs which may be used on a printed circuit board to achieve desired creepage and clearances. Creepage and clearance distances will also change depending on factors such as pollution degree and insulation level.

Table 3. Absolute Maximum Ratings

Parameter	Symbol	Min.	Max.	Units	Note
Storage Temperature	T_S	-55	125	°C	
Operating Temperature	T_A	-40	100	°C	
Output IC Junction Temperature	T_J		150	°C	
Average Input Current	$I_{F(AVG)}$		25	mA	1
Peak Transient Input Current (<1 μ s pulse width, 300pps)	$I_{F(TRAN)}$		1.0	A	
Reverse Input Voltage	V_R		5	V	
"High" Peak Output Current	$I_{OH(PEAK)}$		5.0	A	2
"Low" Peak Output Current	$I_{OL(PEAK)}$		5.0	A	2
Total Output Supply Voltage	$(V_{CC} - V_{EE})$	-0.5	35	V	
Input Current (Rise/Fall Time)	$t_{r(IN)} / t_{f(IN)}$		500	ns	
Output Voltage	$V_{O(PEAK)}$	-0.5	V_{CC}	V	
Output IC Power Dissipation	P_O		800	mW	3
Total Power Dissipation	P_T		850	mW	4

Table 4. Recommended Operating Conditions

Parameter	Symbol	Min.	Max.	Units	Note
Operating Temperature	T_A	-40	100	°C	
Output Supply Voltage	$(V_{CC} - V_{EE})$	15	30	V	
Input Current (ON)	$I_{F(ON)}$	10	16	mA	
Input Voltage (OFF)	$V_{F(OFF)}$	-3.6	0.8	V	

Table 5. Electrical Specifications (DC)

Unless otherwise noted, all typical values are at $T_A = 25^\circ\text{C}$, $V_{CC} - V_{EE} = 30\text{ V}$, $V_{EE} = \text{Ground}$; all Minimum/Maximum specifications are at Recommended Operating Conditions ($T_A = -40$ to 100°C , $I_{F(ON)} = 10$ to 16 mA , $V_{F(OFF)} = -3.6$ to 0.8 V , $V_{CC} = 15$ to 30 V , $V_{EE} = \text{Ground}$)

Parameter	Symbol	Min.	Typ.	Max.	Units	Test Conditions	Fig.	Note
High Level Output Current	I_{OH}	1.0	2.75		A	$V_O = V_{CC} - 4$	2, 3, 17	5
		4.0			A	$V_O = V_{CC} - 15$		2
Low Level Output Current	I_{OL}	1.0	3.5		A	$V_O = V_{EE} + 2.5$	5, 6, 18	5
		4.0			A	$V_O = V_{EE} + 15$		2
High Level Output Voltage	V_{OH}	$V_{CC}-4$	$V_{CC}-3$		V	$I_O = -100\text{ mA}$	1, 3, 19	6, 7
Low Level Output Voltage	V_{OL}		0.1	0.5	V	$I_O = 100\text{ mA}$	4, 6, 20	
High Level Supply Current	I_{CCH}		3.0	5.0	mA	Output open, $I_F = 7$ to 16 mA	7, 8	
Low Level Supply Current	I_{CCL}		3.0	5.0	mA	Output open, $V_F = -3.0$ to $+0.8\text{ V}$		
Threshold Input Current Low to High	I_{FLH}		3.5	8.0	mA	$I_O = 0\text{ mA}$, $V_O > 5\text{ V}$	9, 15, 21	
Threshold Input Voltage High to Low	V_{FHL}	0.8			V			
Input Forward Voltage	V_F	1.2	1.6	1.95	V	$I_F = 10\text{ mA}$	16	
Temperature Coefficient of Input Forward Voltage	$\Delta V_F/\Delta T_A$		-1.3		mV/ $^\circ\text{C}$			
Input Reverse Breakdown Voltage	BV_R	5			V	$I_R = 100\text{ }\mu\text{A}$		
Input Capacitance	C_{IN}		75		pF	$f = 1\text{ MHz}$, $V_F = 0\text{ V}$		
UVLO Threshold	V_{UVLO+}	11.0	12.3	13.5	V	$V_O > 5\text{ V}$, $I_F = 10\text{ mA}$	22, 28	
	V_{UVLO-}	9.5	10.7	12.0				
UVLO Hysteresis	$UVLO_{HYS}$		1.6					

Table 6. Switching Specifications (AC)

Unless otherwise noted, all typical values are at $T_A = 25^\circ\text{C}$, $V_{CC} - V_{EE} = 30\text{ V}$, $V_{EE} = \text{Ground}$; all Minimum/Maximum specifications are at Recommended Operating Conditions ($T_A = -40$ to 100°C , $I_{F(ON)} = 10$ to 16 mA , $V_{F(OFF)} = -3.6$ to 0.8 V , $V_{CC} = 15$ to 30 V , $V_{EE} = \text{Ground}$).

Parameter	Symbol	Min.	Typ.	Max.	Units	Test Conditions	Fig.	Note
Propagation Delay Time to High Output Level	t_{PLH}	0.10	0.30	0.50	μs	$R_g = 10\text{ }\Omega$, $C_g = 10\text{ nF}$, $f = 10\text{ kHz}$, Duty Cycle = 50%, $I_F = 10\text{ mA}$, $V_{CC} = 30\text{ V}$	10, 11, 12, 14 13, 14, 23	
Propagation Delay Time to Low Output Level	t_{PHL}	0.10	0.30	0.50	μs			
Pulse Width Distortion	PWD			0.30	μs			15
Propagation Delay Difference Between Any Two Parts	PDD ($t_{PHL} - t_{PLH}$)		0.35		μs		35, 36	10
Rise Time	t_r		0.1		μs		23	
Fall Time	t_f		0.1		μs			
UVLO to Turn On Delay	$t_{UVLO,ON}$		0.8		μs	$V_O > 5\text{ V}$, $I_F = 10\text{ mA}$	22	
UVLO to Turn Off Delay	$t_{UVLO,OFF}$		0.6		μs	$V_O < 5\text{ V}$, $I_F = 10\text{ mA}$		
Output High Level Common Mode Transient Immunity	$ CM_H $	15	30		kV/ μs	$T_A = 25^\circ\text{C}$, $I_F = 10$ to 16 mA , $V_{CM} = 1500\text{ V}$, $V_{CC} = 30\text{ V}$	24	11, 12
Output Low Level Common Mode Transient Immunity	$ CM_L $	15	30		kV/ μs	$T_A = 25^\circ\text{C}$, $V_F = 0\text{ V}$, $V_{CM} = 1500\text{ V}$, $V_{CC} = 30\text{ V}$		11, 13

Table 7. Package Characteristics

Unless otherwise noted, all typical values are at $T_A = 25^\circ\text{C}$; all Minimum/Maximum specifications are at Recommended Operating Conditions.

Parameter	Symbol	Min.	Typ.	Max.	Units	Test Conditions	Fig.	Note
Input-Output Momentary Withstand Voltage*	V_{ISO}	5000			V_{RMS}	$RH < 50\%$, $t = 1 \text{ min.}, T_A = 25^\circ\text{C}$		8, 9
Input-Output Resistance	R_{I-O}	10^{12}	10^{13}		Ω	$V_{I-O} = 500 V_{DC}$, $T_A = 25^\circ\text{C}$		9
		10^{11}				$V_{I-O} = 500 V_{DC}$, $T_A = 100^\circ\text{C}$		
Input-Output Capacitance	C_{I-O}		0.5	0.6	pF	$f = 1 \text{ MHz}$		
LED-to-Ambient Thermal Resistance	θ_{LA}				$^\circ\text{C/W}$		29, 30, 31	
LED-to-Detector Thermal Resistance	θ_{LD}		See Thermal Model Section			See Thermal Model in Application Notes Section		
Detector-to-Ambient Thermal Resistance	θ_{DA}							

* The Input-Output Momentary Withstand Voltage is a dielectric voltage rating that should not be interpreted as an input-output continuous voltage rating. For the continuous voltage rating, refer to your equipment level safety specification or Avago Technologies Application Note 1074 entitled "Optocoupler Input-Output Endurance Voltage."

Notes:

- Derate linearly above 70°C free-air temperature at a rate of $0.3 \text{ mA}/^\circ\text{C}$.
- Maximum pulse width = $10 \mu\text{s}$. This value is intended to allow for component tolerances for designs with I_O peak minimum = 4.0 A . See Applications section for additional details on limiting I_{OH} peak.
- Derate linearly above 70°C free-air temperature at a rate of $4.8 \text{ mA}/^\circ\text{C}$.
- Derate linearly above 70°C free-air temperature at a rate of $5.4 \text{ mA}/^\circ\text{C}$.
- Maximum pulse width = $50 \mu\text{s}$.
- In this test V_{OH} is measured with a dc load current. When driving capacitive loads V_{OH} will approach V_{CC} as I_{OH} approaches zero amps.
- Maximum pulse width = 1 ms .
- In accordance with UL1577, each optocoupler is proof tested by applying an insulation test voltage $\geq 6000 \text{ Vrms}$ for 1 second (leakage detection current limit, $I_{I-O} \leq 5 \mu\text{A}$).
- Device considered a two-terminal device: pins 1, 2, 3, and 4 shorted together and pins 5, 6, 7, and 8 shorted together.
- The difference between t_{PHL} and t_{PLH} between any two ACNW3190 parts under the same test condition.
- Pins 1 and 4 need to be connected to LED common.
- Common mode transient immunity in the high state is the maximum tolerable dV_{CM}/dt of the common mode pulse, V_{CM} , to assure that the output will remain in the high state (i.e., $V_O > 15.0 \text{ V}$).
- Common mode transient immunity in a low state is the maximum tolerable dV_{CM}/dt of the common mode pulse, V_{CM} , to assure that the output will remain in a low state (i.e., $V_O < 1.0 \text{ V}$).
- This load condition approximates the gate load of a $1200 \text{ V}/100\text{A}$ IGBT.
- Pulse Width Distortion (PWD) is defined as $|t_{PHL} - t_{PLH}|$ for any given device.

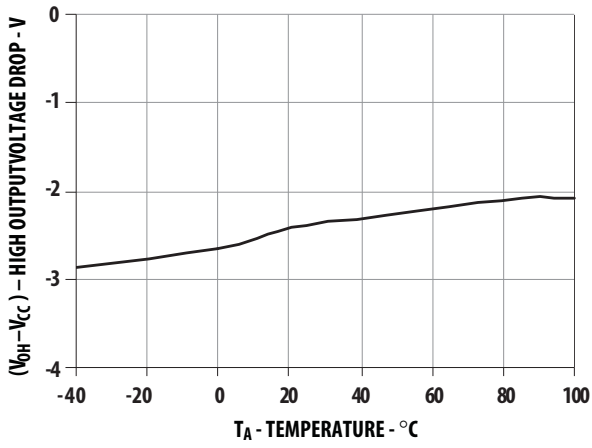

Figure 1. V_{OH} vs. Temperature

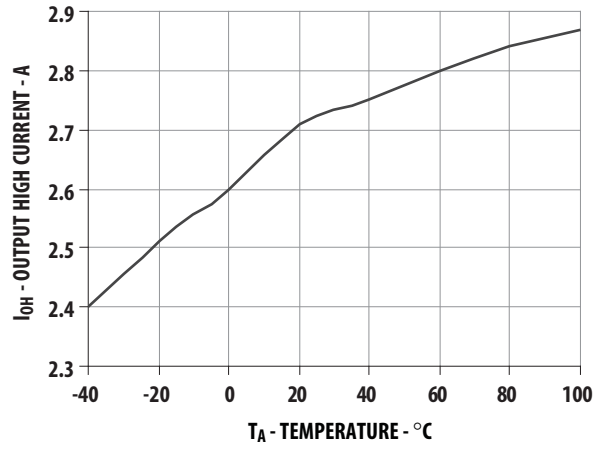

Figure 2. I_{OH} vs. Temperature

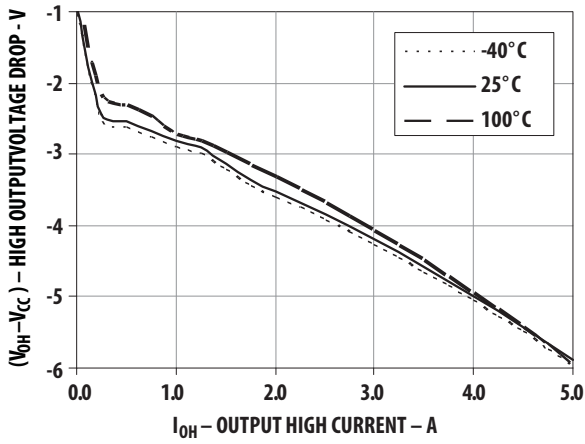

Figure 3. V_{OH} vs. I_{OH}

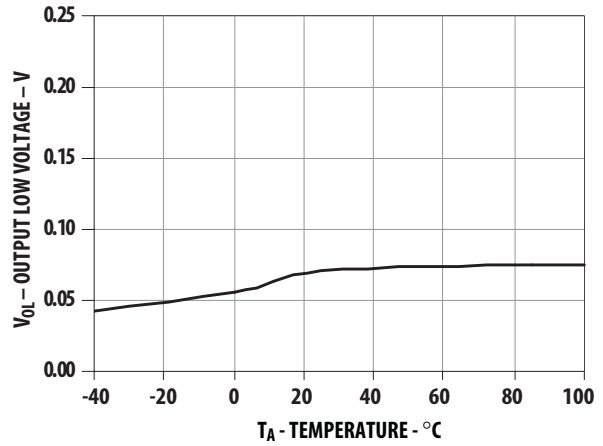

Figure 4. V_{OL} vs. Temperature

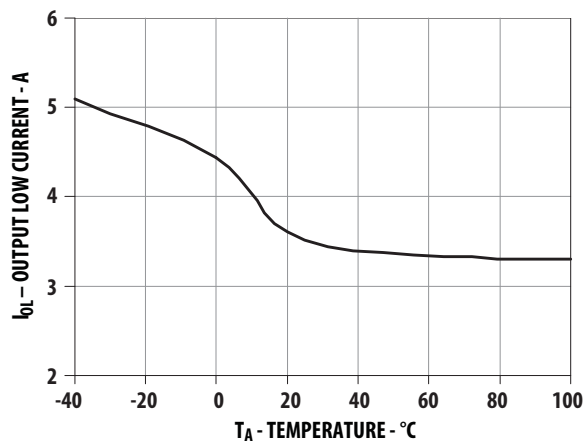

Figure 5. I_{OL} vs. Temperature

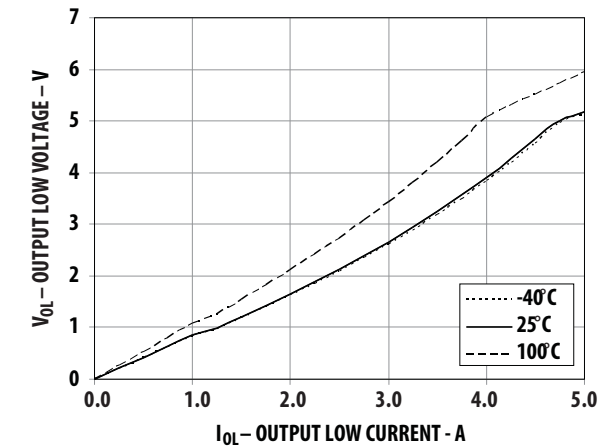

Figure 6. V_{OL} vs. I_{OL}

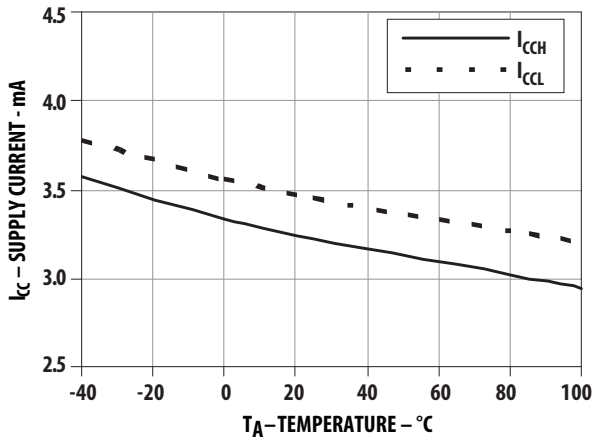

Figure 7. I_{CC} vs. Temperature

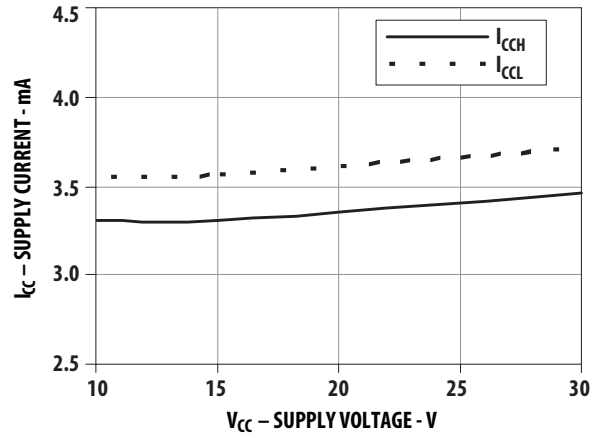

Figure 8. I_{CC} vs. V_{CC}

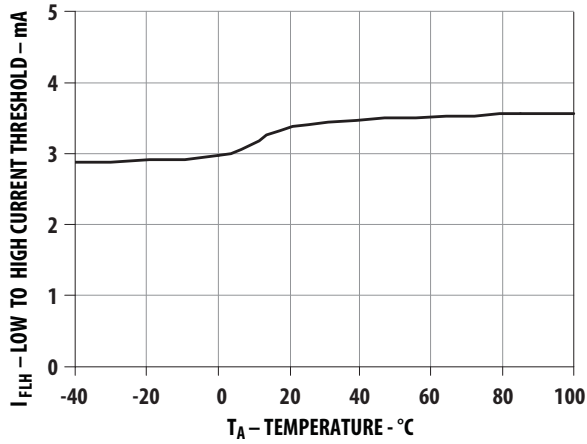

Figure 9. I_{FLH} vs. Temperature

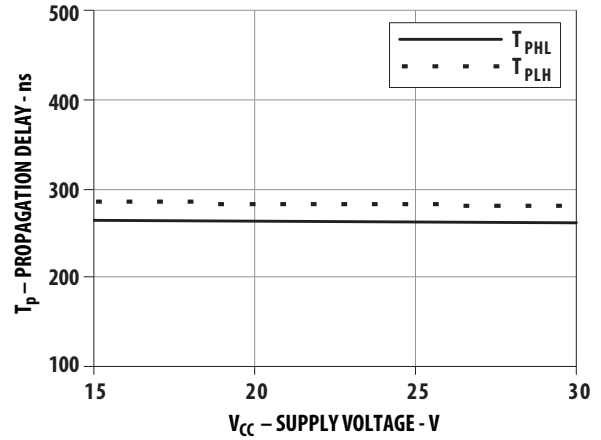

Figure 10. Propagation delay vs. V_{CC}

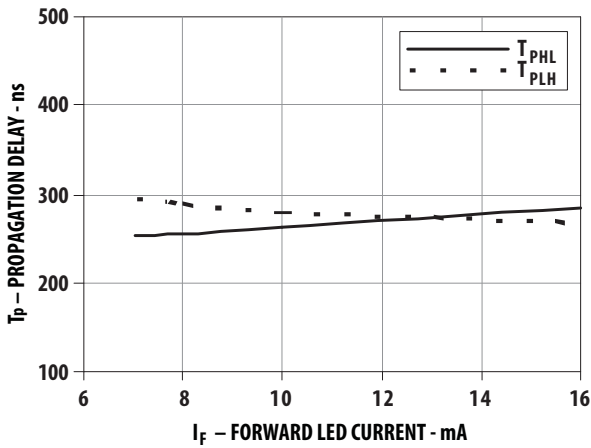

Figure 11. Propagation delay vs. I_f

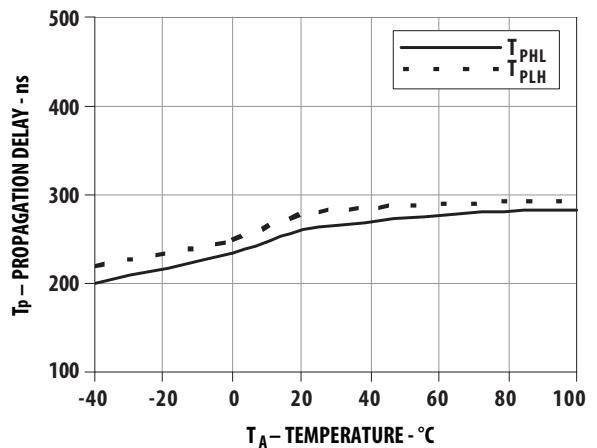

Figure 12. Propagation delay vs. Temperature

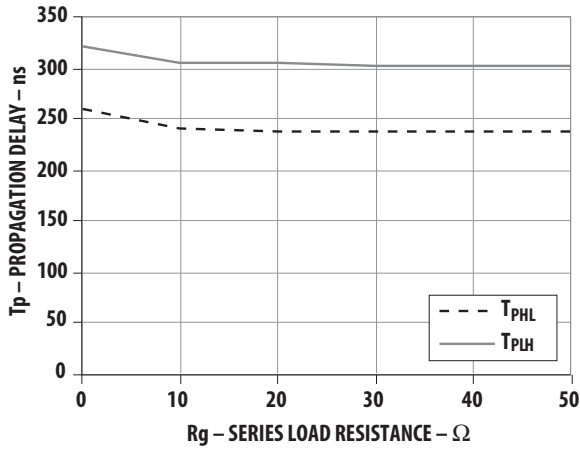

Figure 13. Propagation Delay vs. Rg

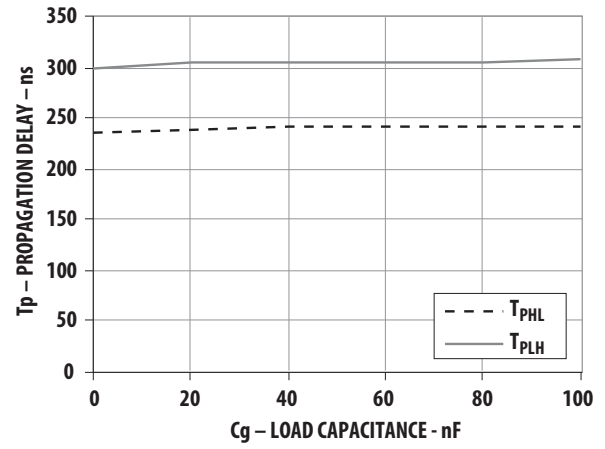

Figure 14. Propagation Delay vs. Cg

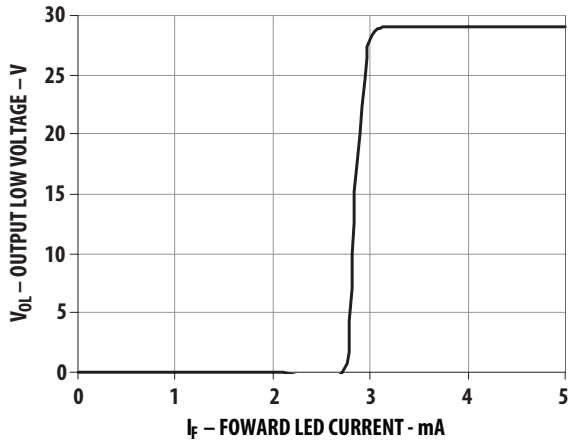

Figure 15. Transfer Characteristics

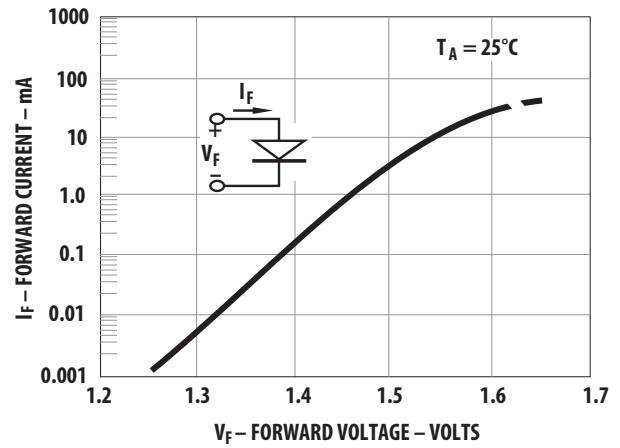

Figure 16. Input Current vs. Forward Voltage

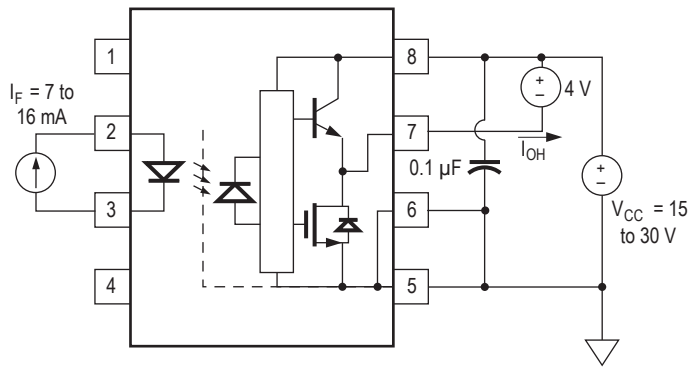

Figure 17. I_{OH} Test Circuit

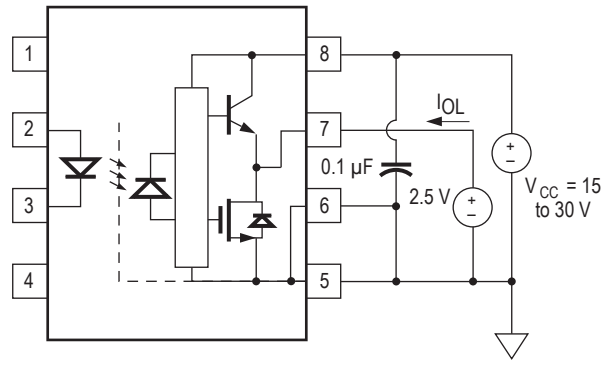

Figure 18. I_{OL} Test Circuit

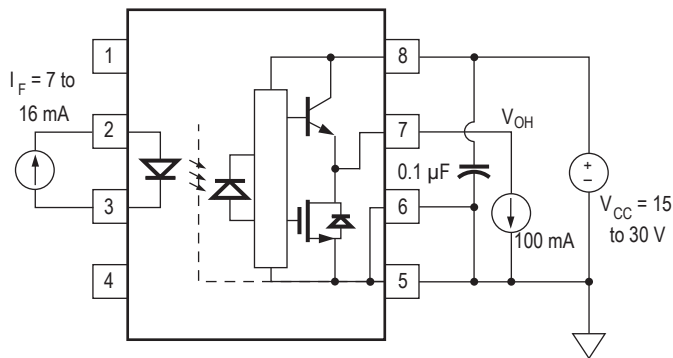

Figure 19. V_{OH} Test Circuit

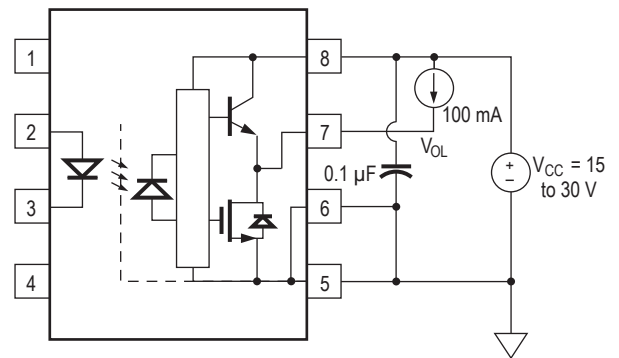

Figure 20. V_{OL} Test Circuit

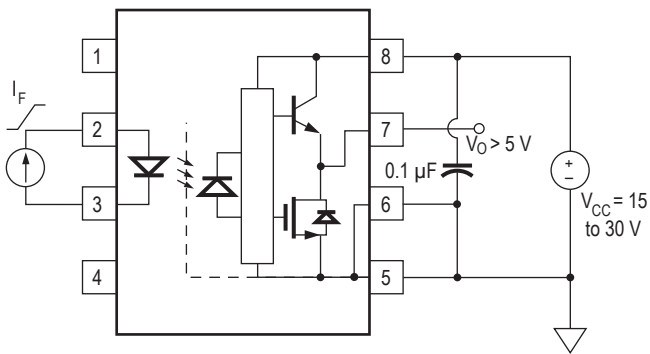

Figure 21. I_{FLH} Test Circuit

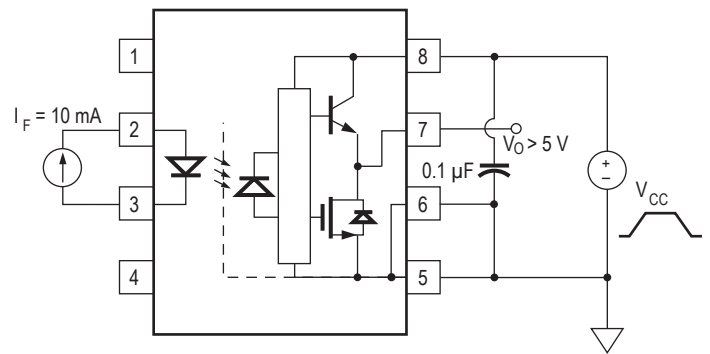

Figure 22. UVLO Test Circuit

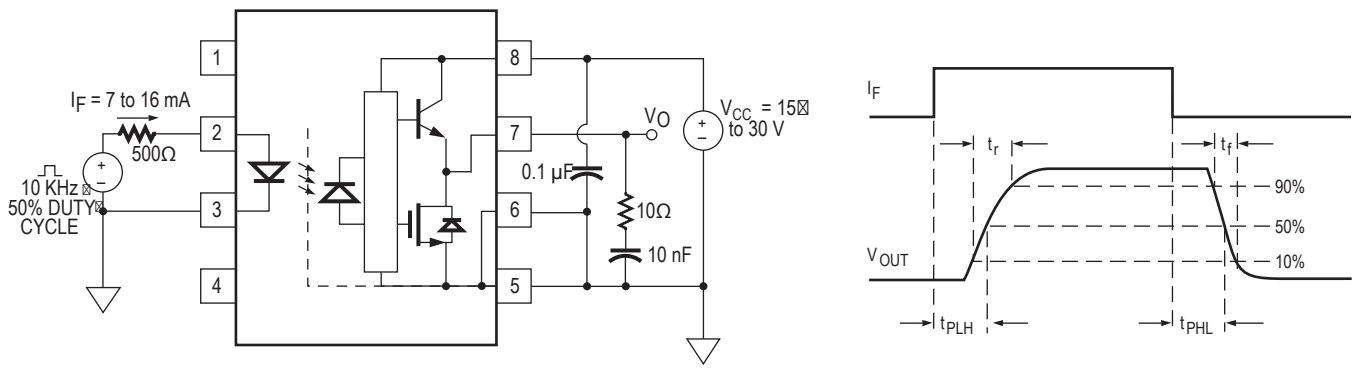

Figure 23. t_{PLH} , t_{PHL} , t_r , and t_f Test Circuit and Waveforms

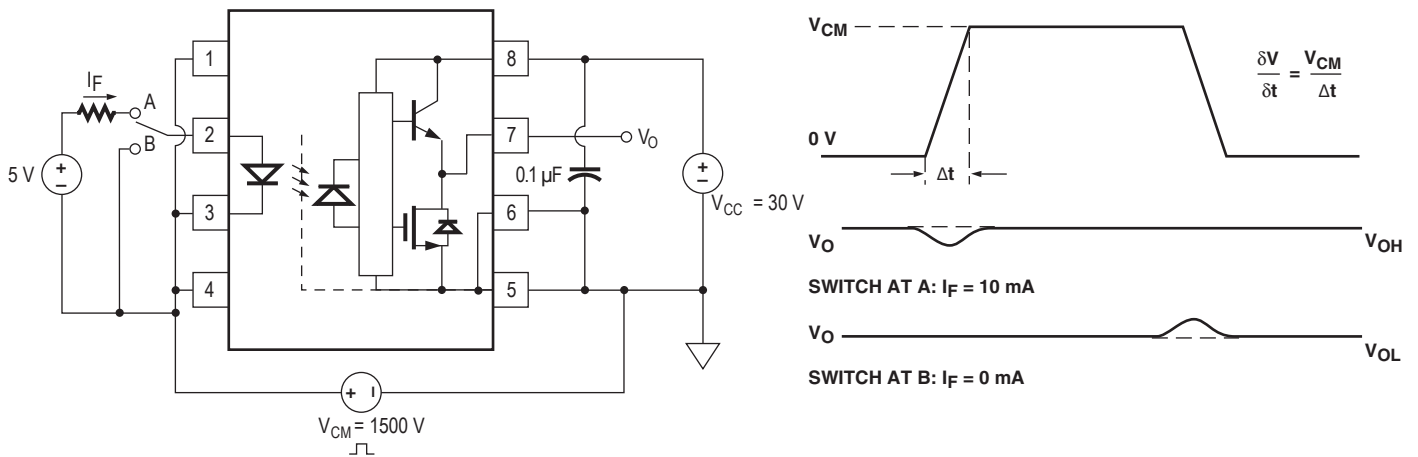

Figure 24. CMR Test Circuit and Waveforms

Application Notes

Figure 25 and 26 show two recommended application circuits. Figure 25 shows a single power supply gate driver using the driver's maximum V_{OL} value of 0.5V. Figure 26 shows a dual power supply gate driver circuit which is applicable for higher power IGBT driving due to the existence of higher miller capacitance in these IGBTs.

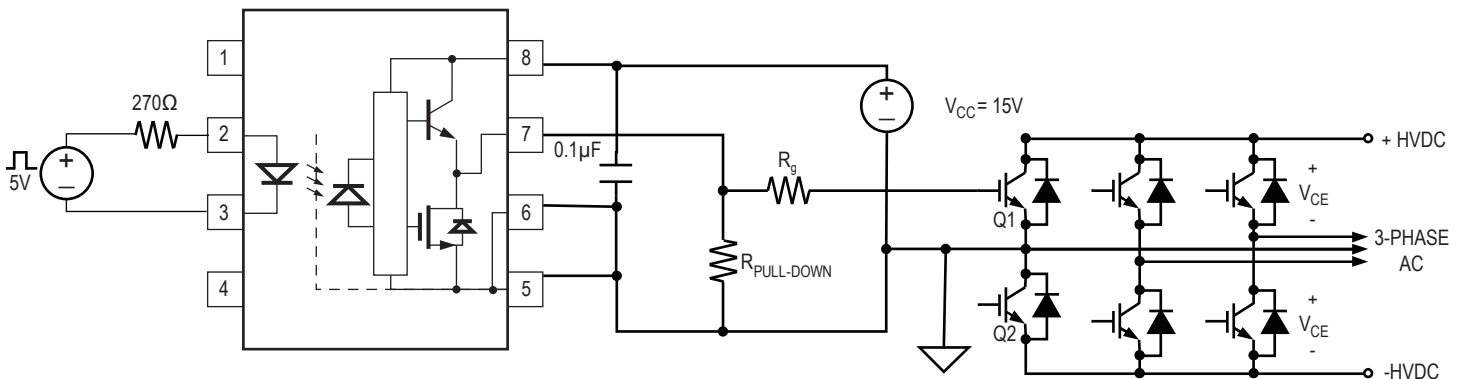

Figure 25. Recommended LED drive and application circuit

For high side bootstrap driving, note that the bypass capacitor of 0.1 μ F in parallel with 10 μ F or above to be connected across VCC and VEE is important to deliver high peak output current.

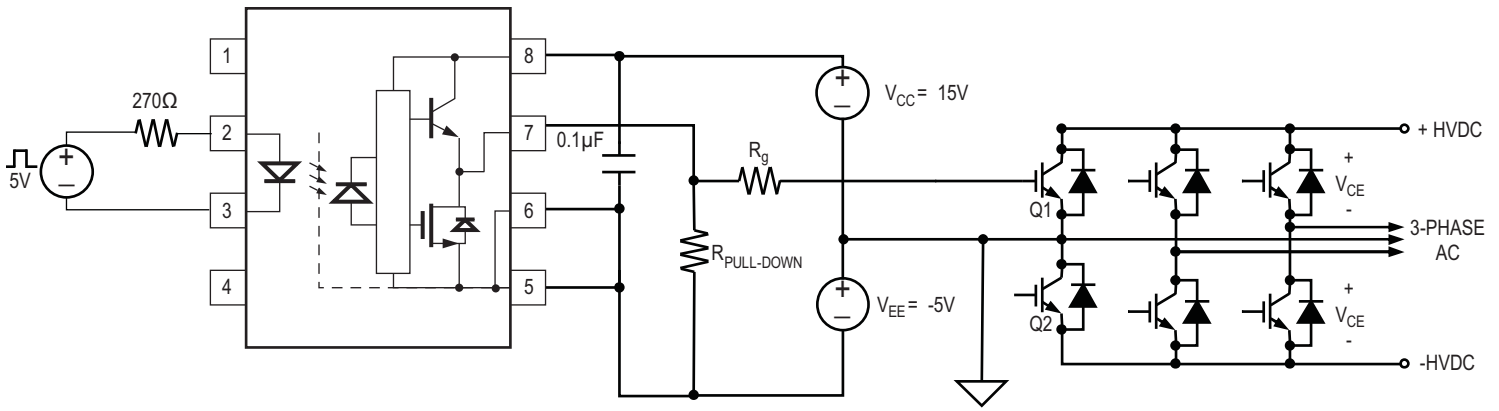

Figure 26. ACNW3190 typical application circuit with negative IGBT gate drive

Selecting the Gate Resistor (R_g) to minimize IGBT Switching Losses.

Step 1: Calculate R_g Minimum from the I_{OL} Peak Specification

The IGBT and R_g in Figure 26 can be analyzed as a simple RC circuit with a voltage supplied by the ACNW3190. The operating temperature is 100°C.

$$R_g \geq \frac{(V_{CC} - V_{EE} - V_{OL})}{I_{OLPEAK}}$$

$$= \frac{(15V + 5V - 3.5V)}{4A}$$

$$\approx 4.3\Omega$$

The V_{OL} value of 3.5V in the previous equation is a conservative value of V_{OL} at the peak current of 4.0A (see Figure 6). At lower R_g values the voltage supplied by the ACNW3190 is not an ideal voltage step. This results in lower peak currents (more margin) than predicted by this analysis. When negative gate drive is not used, V_{EE} in the previous equation is equal to zero volts.

Step 2: Check the ACNW3190 Power Dissipation and Increase R_g if Necessary.

The ACNW3190 total power dissipation (P_T) is equal to the sum of the emitter power (P_E) and the output power (P_O):

$$P_T = P_E + P_O$$

$$P_E = I_F * V_F * \text{Duty Cycle}$$

$$P_O = P_{O(BIAS)} + P_{O(SWITCHING)}$$

$$= I_{CC} * (V_{CC} - V_{EE}) + E_{SW}(R_g, Q_g) * f$$

For the circuit in Figure 26 with I_F (worst case) = 16 mA, R_g = 4.3Ω, Max Duty Cycle = 80%, Q_g = 1000 nC, f = 15 kHz and T_A max = 85°C:

$$P_E = 16 \text{ mA} * 1.95V * 0.8 = 25 \text{ mW}$$

$$P_O = 3.25 \text{ mA} * 20 \text{ V} + 13\mu\text{J} * 15 \text{ kHz}$$

$$= 65 \text{ mW} + 195 \text{ mW}$$

$$= 260 \text{ mW}$$

$$< 728 \text{ mW} (P_{O(MAX)} @ 85^\circ\text{C} = 800 \text{ mW} - 15\text{C} * 4.8 \text{ mW/C})$$

The value of 3.25 mA for I_{CC} in the previous equation was obtained by derating the I_{CC} max of 5 mA to I_{CC} max at 100C (see Figure 7).

The above computation shows that the power dissipation is within the specified limits. However, designers should verify that the thermal limits have not been violated by using the thermal model provided in this datasheet. This thermal model obtained based on JEDEC specification.

PE Parameter	Description
I _F	LED Current
V _F	LED On Voltage
Duty Cycle	Maximum LED Duty Cycle

P _O Parameter	Description
I _{CC}	Supply Current
V _{CC}	Positive Supply Voltage
V _{EE}	Negative Supply Voltage
E _{sw} (R _g , Q _g)	Energy Dissipated in the HCPL-3120 for each IGBT Switching Cycle (See Figure 27)
f	Switching Frequency

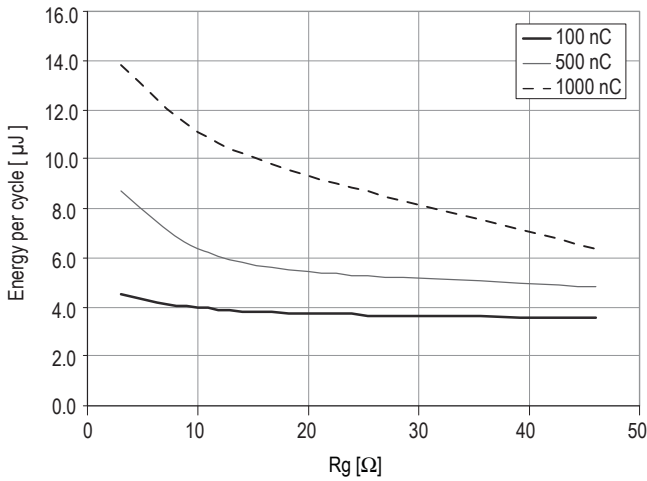

Figure 27. Energy dissipated in the ACNW3190 for each IGBT switching cycle

Under Voltage Lockout Feature

The ACNW3190 contains an under voltage lockout (UVLO) feature that is designed to protect the IGBT under fault conditions which cause the ACNW3190 supply voltage (equivalent to the fully-charged IGBT gate voltage) to drop below a level necessary to keep the IGBT in a low resistance state. When the ACNW3190 output is in the high state and the supply voltage drops below the ACNW3190 V_{UVLO-} threshold ($9.5 < V_{UVLO-} < 12.0$) the optocoupler output will go into the low state with a typical delay, UVLO Turn Off Delay, of 0.6 μ s. When the ACNW3190 output is in the low state and the supply voltage rises above the ACNW3190 V_{UVLO+} threshold ($11.0 < V_{UVLO+} < 13.5$) the optocoupler output will go into the high state (assumes LED is "ON") with a typical delay, UVLO Turn On Delay, of 0.8 μ s.

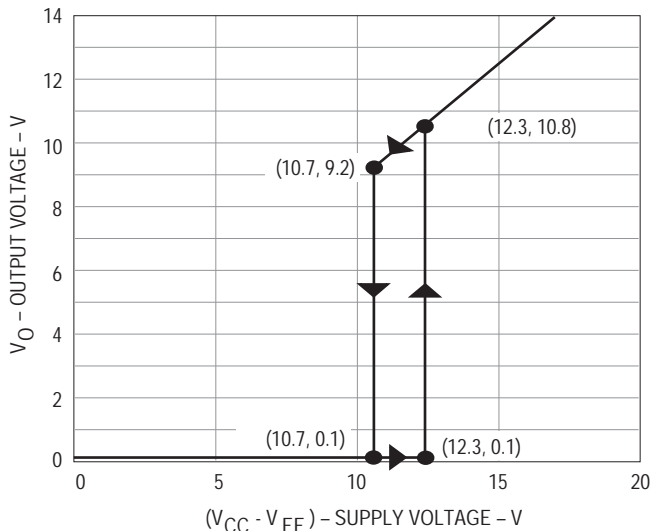

Figure 28. Under Voltage Lock Out

Thermal Model

Introduction

For application which requires an output gate current more than 2A, adequate PCB pad heat-sink must be provided to dissipate the power loss in the package. Failure to provide proper heat dissipation will potentially damage the gate drive after pro-long usage. This thermal model allows designer to compute the temperature of the LED and detector.

Definitions

θ_1 : Thermal impedance from LED junction to ambient

θ_2 : Thermal impedance from LED to detector (output IC)

θ_3 : Thermal impedance from detector (output IC) junction to ambient

Ambient Temperature: Measured approximately 1.25 cm above the optocoupler, with no forced air.

Description

This thermal model assumes that an 8-pin single-channel plastic package optocoupler is soldered into a 7.62 cm x 7.62 cm printed circuit board (PCB). The temperature at the LED and Detector junctions of the optocoupler can be calculated using the equations below.

$$\Delta T_{EA} = A_{11} * P_E + A_{12} * P_D$$

$$\Delta T_{DA} = A_{21} * P_E + A_{22} * P_D$$

where,

ΔT_{EA} = Temperature difference between ambient and LED

ΔT_{DA} = Temperature difference between ambient and detector

P_E = Power dissipation from LED

P_D = Power dissipation from detector

A_{11} , A_{12} , A_{21} , A_{22} thermal coefficients (units in $^{\circ}C/W$) are functions of the thermal impedances θ_1 , θ_2 , θ_3 (See Note 2).

Table 1. Thermal Model-B Coefficient Data (units in $^{\circ}C/W$)

S (cm)	A11	A12, A21	A22
1	218.9	39.31	55.3
2	200.6	29.8	45
4	198	23.59	41.7
JeDEC Specifications			
low K board	254	50.3	66.8
High K board	151.2	16.72	39.06

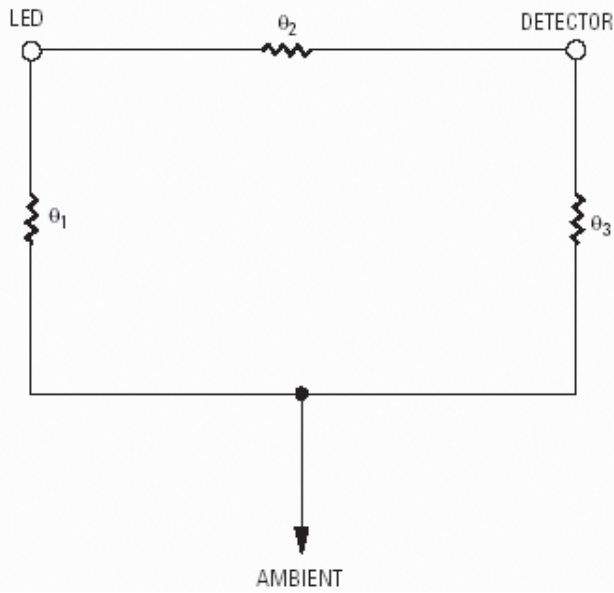

Figure 29. Thermal Model-B Diagram

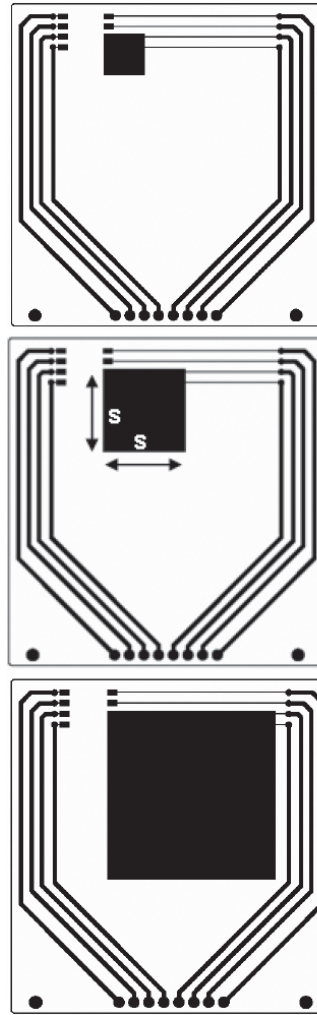

Figure 30. Evaluation thermal board design

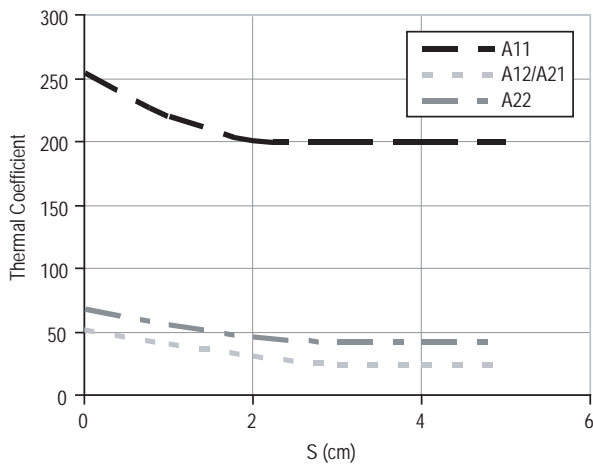

Figure 31. Thermal Coefficient Plot against S

Notes:

1. Maximum junction temperature for above parts: 150 °C.
2. $A11 = \theta_1 || (\theta_2 + \theta_3)$; $A12 = A21 = (\theta_1 \theta_2) / (\theta_1 + \theta_2 + \theta_3)$; $A22 = \theta_3 || (\theta_2 + \theta_3)$.

For product information and a complete list of distributors, please go to our web site: www.avagotech.com

Avago, Avago Technologies, and the A logo are trademarks of Avago Technologies in the United States and other countries. Data subject to change. Copyright © 2005-2012 Avago Technologies. All rights reserved. AV02-0598EN - July 5, 2012



Looking for pricing, stock, or lifecycle information?

Click below to explore more details on WIN SOURCE:

 [View TDA21220](#) on WIN SOURCE

 [Infineon Technologies](#) Information

Optimize Your Supply Chain with WIN SOURCE Solutions

-  Global Sourcing Solution
-  Obsolete Management
-  Cost Control Management
-  Shortage Management
-  Alternative Solution
-  Excess Inventory Management