



**THE DATASHEET OF
TDA18219HN/C1,518**





TDA18219HN

Silicon tuner for terrestrial and cable digital TV reception

Rev. 6 — 13 July 2012

Product short data sheet

1. General description

The TDA18219HN supports all digital TV standards and delivers a LOW IF (LIF) signal to a channel demodulator for digital TV. Standards that are covered include DVB-T/T2, ISDB-T, DTMB, ATSC and DVB-C.

The TDA18219HN facilitates design-ins by:

- Allowing easy on-board integration
- Drastically reducing the size of the tuner function
- Providing flexibility in system solution development

2. Features and benefits

- Fully integrated IF selectivity; eliminating the need for external SAW filters
- Fully integrated oscillators
- Alignment free
- Single 3.3 V supply voltage
- LOW power consumption
- Integrated wideband gain control
- Crystal oscillator output buffer (16 MHz) for single crystal applications
- I²C-bus interface compatible with 3.3 V microcontrollers
- Easy programming
- 5 ms tuning time
- LIF channel center frequency output ranging from 3 MHz to 5 MHz
- 1.7 MHz, 6 MHz, 7 MHz, 8 MHz and 10 MHz channel bandwidths
- Loop-Through (LT)
- RoHS compliant

3. Quick reference data

Table 1. Quick reference data

Symbol	Parameter	Conditions	Min	Typ	Max	Unit
f_{RF}	RF frequency	full range of RF input	42	-	870	MHz
NF_{tun}	tuner noise figure	75 Ω source; maximum gain	-	5.0	5.9	dB



Table 1. Quick reference data ...continued

Symbol	Parameter	Conditions	Min	Typ	Max	Unit
ϕ_{jit}	phase jitter	UHF; integrated from 1 kHz to 4 MHz	-	0.5	0.7	degree
α_{image}	image rejection	worst case for image rejection and 4 MHz IF frequency for levels above -50 dBm	55	63	-	dB
ICP _{1dB}	1 dB input compression point	at tuner input and minimum gain	124	-	-	dB μ V

4. Ordering information

Table 2. Ordering information

Type number	Package		
	Name	Description	Version
TDA18219HN/C1	HVQFN40	plastic thermal enhanced very thin quad flat package; no leads; 40 terminals; body 6 × 6 × 0.85 mm	SOT618-1

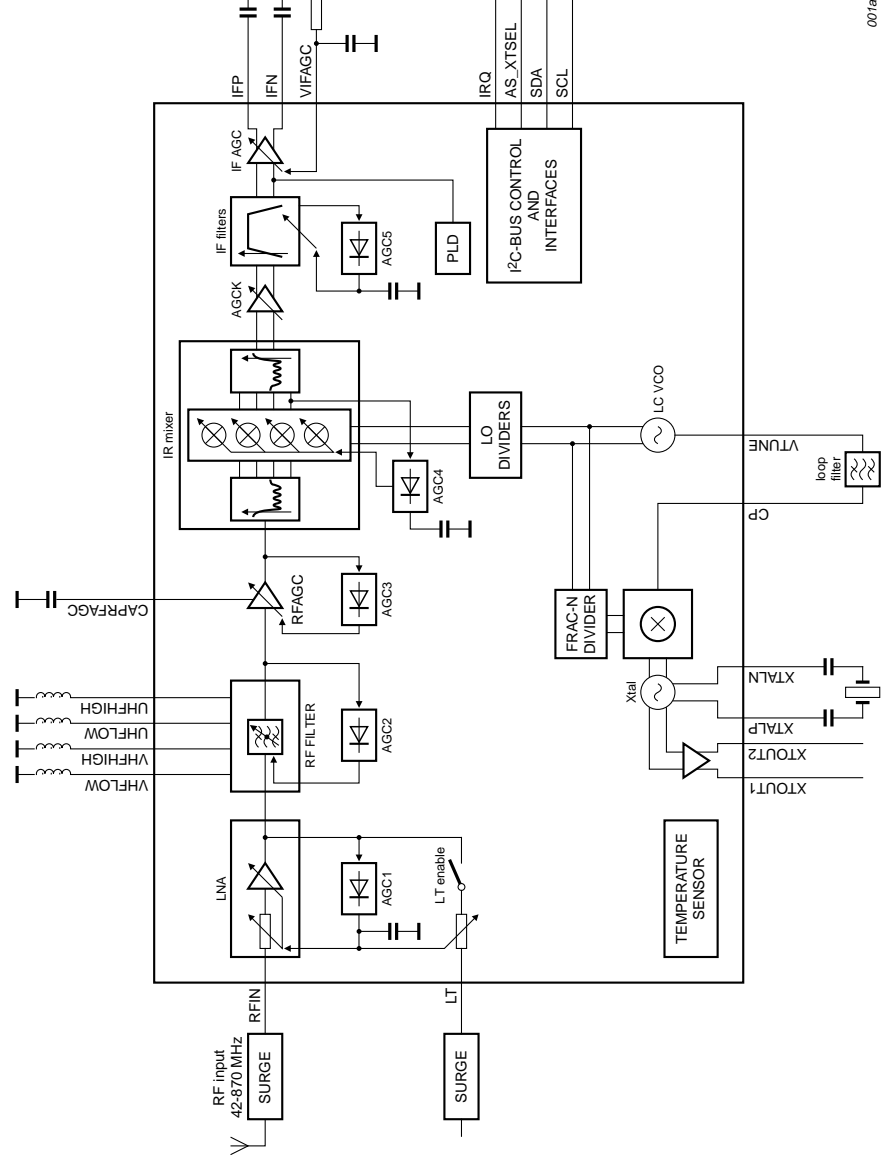

001a

Fig 1. Block diagram

6. Limiting values

Table 3. Limiting values

In accordance with the Absolute Maximum Rating System (IEC 60134).

Symbol	Parameter	Conditions	Min	Max	Unit
V _{CC}	supply voltage		-0.3	+3.6	V
V _I	input voltage	pins SDA and SCL	-0.3	+3.6	V
		all other pins:			
		V _{CC} < 3.3 V	-0.3	V _{CC} + 0.3	V
		V _{CC} > 3.3 V	-0.3	+3.6	V
T _{stg}	storage temperature		-40	+150	°C
T _j	junction temperature		-	+125	°C
T _{amb}	ambient temperature		-20	[1]	°C
V _{ESD}	electrostatic discharge voltage	EIA/JESD22-A114 (human body model)	-2	+2	kV
		EIA/JESD22-C101-C (FCDM) class III[2]	750	-	V

[1] The maximum allowed ambient temperature T_{amb(max)} depends on the assembly conditions of the package and especially on the design of the Printed-Circuit Board (PCB) and die connection. The application mounting must be done in such a way that the maximum junction temperature is never exceeded. The junction temperature can be obtained by reading the temperature sensor bit via I²C-bus. The junction temperature: T_j = T_{amb} + ΔT_{j-c}, where ΔT_{j-c} = power × R_{th}.

[2] Class III: 500 V to 1000 V.

7. Abbreviations

Table 4. Abbreviations

Acronym	Description
AGC	Automatic Gain Control
AGCK	Automatic Gain Control step Killer
DTMB	Digital Terrestrial Multimedia Broadcast
DVB	Digital Video Broadcasting
DVB-T/C/H	DVB-Terrestrial/Cable/Handheld
ESD	ElectroStatic Discharge
FCDM	Field-induced Charged-Device Model
FRAC-N	FRActional-N
IC	Integrated Circuit
IF	Intermediate Frequency
IR	Image Rejection
IRQ	Interrupt ReQuest
ISDB-T	Integrated Services Digital Broadcasting - Terrestrial
LC-VCO	Inductors and Capacitors - Voltage Controlled Oscillator
LNA	Low-Noise Amplifier
LO	Local Oscillator
LT	Loop-Through
RF	Radio Frequency
RoHS	Restriction of Hazardous Substances

Table 4. Abbreviations ...continued

Acronym	Description
SAW	Surface Acoustic Wave
SCL	Serial CLock line
SDA	Serial DAta line
UHF	Ultra High Frequency
VCO	Voltage Controlled Oscillator
VHF	Very High Frequency

8. Revision history

Table 5. Revision history

Document ID	Release date	Data sheet status	Change notice	Supersedes
TDA18219HN_SDS v.6 ^[1]	20120713	Product short data sheet	-	TDA18219HN_SDS v.4
Modifications:	<ul style="list-style-type: none"> • Section 1: updated • Table 3: updated T_j maximum value from 120 °C to 125 °C 			
TDA18219HN_SDS v.4	20110329	Product short data sheet	-	TDA18219HN_SDS v.3
TDA18219HN_SDS v.3	20101001	Product short data sheet	-	TDA18219HN_SDS v.2
TDA18219HN_SDS v.2 ^[2]	20100816	Preliminary short data sheet	-	-

[1] Revision 5 is not available.

[2] Revision 1 is not available.

9. Legal information

9.1 Data sheet status

Document status ^{[1][2]}	Product status ^[3]	Definition
Objective [short] data sheet	Development	This document contains data from the objective specification for product development.
Preliminary [short] data sheet	Qualification	This document contains data from the preliminary specification.
Product [short] data sheet	Production	This document contains the product specification.

[1] Please consult the most recently issued document before initiating or completing a design.

[2] The term 'short data sheet' is explained in section "Definitions".

[3] The product status of device(s) described in this document may have changed since this document was published and may differ in case of multiple devices. The latest product status information is available on the Internet at URL <http://www.nxp.com>.

9.2 Definitions

Draft — The document is a draft version only. The content is still under internal review and subject to formal approval, which may result in modifications or additions. NXP Semiconductors does not give any representations or warranties as to the accuracy or completeness of information included herein and shall have no liability for the consequences of use of such information.

Short data sheet — A short data sheet is an extract from a full data sheet with the same product type number(s) and title. A short data sheet is intended for quick reference only and should not be relied upon to contain detailed and full information. For detailed and full information see the relevant full data sheet, which is available on request via the local NXP Semiconductors sales office. In case of any inconsistency or conflict with the short data sheet, the full data sheet shall prevail.

Product specification — The information and data provided in a Product data sheet shall define the specification of the product as agreed between NXP Semiconductors and its customer, unless NXP Semiconductors and customer have explicitly agreed otherwise in writing. In no event however, shall an agreement be valid in which the NXP Semiconductors product is deemed to offer functions and qualities beyond those described in the Product data sheet.

9.3 Disclaimers

Limited warranty and liability — Information in this document is believed to be accurate and reliable. However, NXP Semiconductors does not give any representations or warranties, expressed or implied, as to the accuracy or completeness of such information and shall have no liability for the consequences of use of such information. NXP Semiconductors takes no responsibility for the content in this document if provided by an information source outside of NXP Semiconductors.

In no event shall NXP Semiconductors be liable for any indirect, incidental, punitive, special or consequential damages (including - without limitation - lost profits, lost savings, business interruption, costs related to the removal or replacement of any products or rework charges) whether or not such damages are based on tort (including negligence), warranty, breach of contract or any other legal theory.

Notwithstanding any damages that customer might incur for any reason whatsoever, NXP Semiconductors' aggregate and cumulative liability towards customer for the products described herein shall be limited in accordance with the *Terms and conditions of commercial sale* of NXP Semiconductors.

Right to make changes — NXP Semiconductors reserves the right to make changes to information published in this document, including without limitation specifications and product descriptions, at any time and without notice. This document supersedes and replaces all information supplied prior to the publication hereof.

Suitability for use — NXP Semiconductors products are not designed, authorized or warranted to be suitable for use in life support, life-critical or safety-critical systems or equipment, nor in applications where failure or malfunction of an NXP Semiconductors product can reasonably be expected to result in personal injury, death or severe property or environmental damage. NXP Semiconductors and its suppliers accept no liability for inclusion and/or use of NXP Semiconductors products in such equipment or applications and therefore such inclusion and/or use is at the customer's own risk.

Applications — Applications that are described herein for any of these products are for illustrative purposes only. NXP Semiconductors makes no representation or warranty that such applications will be suitable for the specified use without further testing or modification.

Customers are responsible for the design and operation of their applications and products using NXP Semiconductors products, and NXP Semiconductors accepts no liability for any assistance with applications or customer product design. It is customer's sole responsibility to determine whether the NXP Semiconductors product is suitable and fit for the customer's applications and products planned, as well as for the planned application and use of customer's third party customer(s). Customers should provide appropriate design and operating safeguards to minimize the risks associated with their applications and products.

NXP Semiconductors does not accept any liability related to any default, damage, costs or problem which is based on any weakness or default in the customer's applications or products, or the application or use by customer's third party customer(s). Customer is responsible for doing all necessary testing for the customer's applications and products using NXP Semiconductors products in order to avoid a default of the applications and the products or of the application or use by customer's third party customer(s). NXP does not accept any liability in this respect.

Limiting values — Stress above one or more limiting values (as defined in the Absolute Maximum Ratings System of IEC 60134) will cause permanent damage to the device. Limiting values are stress ratings only and (proper) operation of the device at these or any other conditions above those given in the Recommended operating conditions section (if present) or the Characteristics sections of this document is not warranted. Constant or repeated exposure to limiting values will permanently and irreversibly affect the quality and reliability of the device.

Terms and conditions of commercial sale — NXP Semiconductors products are sold subject to the general terms and conditions of commercial sale, as published at <http://www.nxp.com/profile/terms>, unless otherwise agreed in a valid written individual agreement. In case an individual agreement is concluded only the terms and conditions of the respective agreement shall apply. NXP Semiconductors hereby expressly objects to applying the customer's general terms and conditions with regard to the purchase of NXP Semiconductors products by customer.

No offer to sell or license — Nothing in this document may be interpreted or construed as an offer to sell products that is open for acceptance or the grant, conveyance or implication of any license under any copyrights, patents or other industrial or intellectual property rights.

Export controlled classification (0) — For the content of this document no export license is required, except when the document will be used in countries under sanction, for military applications, Weapons of Mass Destruction (WMD) or missiles, or by listed parties. In that case authorization is required from the competent authorities, and the export or re-export without proper export authorization is strictly forbidden. If the document contains material of U.S. origin, the Export Control Classification Number (ECCN) is EAR99 and the U.S. sanction laws apply. Otherwise no ECCN number is applicable.

Quick reference data — The Quick reference data is an extract of the product data given in the Limiting values and Characteristics sections of this document, and as such is not complete, exhaustive or legally binding.

Non-automotive qualified products — Unless this data sheet expressly states that this specific NXP Semiconductors product is automotive qualified, the product is not suitable for automotive use. It is neither qualified nor tested in accordance with automotive testing or application requirements. NXP Semiconductors accepts no liability for inclusion and/or use of non-automotive qualified products in automotive equipment or applications.

In the event that customer uses the product for design-in and use in automotive applications to automotive specifications and standards, customer (a) shall use the product without NXP Semiconductors' warranty of the product for such automotive applications, use and specifications, and (b) whenever customer uses the product for automotive applications beyond NXP Semiconductors' specifications such use shall be solely at customer's own risk, and (c) customer fully indemnifies NXP Semiconductors for any

liability, damages or failed product claims resulting from customer design and use of the product for automotive applications beyond NXP Semiconductors' standard warranty and NXP Semiconductors' product specifications.

Translations — A non-English (translated) version of a document is for reference only. The English version shall prevail in case of any discrepancy between the translated and English versions.

9.4 Licenses

ICs with DVB-T or DVB-T2 functionality

Use of this product in any manner that complies with the DVB-T or the DVB-T2 standard may require licenses under applicable patents of the DVB-T respectively the DVB-T2 patent portfolio, which license is available from Sisvel S.p.A., Via Sestriere 100, 10060 None (TO), Italy, and under applicable patents of other parties.

9.5 Trademarks

Notice: All referenced brands, product names, service names and trademarks are the property of their respective owners.

I²C-bus — logo is a trademark of NXP B.V.

10. Contact information

For more information, please visit: <http://www.nxp.com>

For sales office addresses, please send an email to: salesaddresses@nxp.com

11. Contents

1	General description	1
2	Features and benefits	1
3	Quick reference data	1
4	Ordering information	2
5	Block diagram	3
6	Limiting values	4
7	Abbreviations	4
8	Revision history	5
9	Legal information	6
9.1	Data sheet status	6
9.2	Definitions	6
9.3	Disclaimers	6
9.4	Licenses	7
9.5	Trademarks	7
10	Contact information	7
11	Contents	8

Please be aware that important notices concerning this document and the product(s) described herein, have been included in section 'Legal information'.

© NXP B.V. 2012.

All rights reserved.

For more information, please visit: <http://www.nxp.com>

For sales office addresses, please send an email to: salesaddresses@nxp.com

Date of release: 13 July 2012

Document identifier: TDA18219HN_SDS

Looking for pricing, stock, or lifecycle information?

Click below to explore more details on WIN SOURCE:

- ⊖ [View TDA18219HN/C1,518 on WIN SOURCE](#)
- ⊖ [NXP / Nexperia Information](#)

Optimize Your Supply Chain with WIN SOURCE Solutions

- ✓ Global Sourcing Solution
- ✓ Obsolete Management
- ✓ Cost Control Management
- ✓ Shortage Management
- ✓ Alternative Solution
- ✓ Excess Inventory Management