



**THE DATASHEET OF
79RC32K438-300BBG**



Features

◆ 32-bit CPU Core

- MIPS32 instruction set
- Cache Sizes: 16KB instruction and data caches, 4-Way set associative, cache line locking, non-blocking prefetches
- 16 dual-entry JTLB with variable page sizes
- 3-entry instruction TLB
- 3-entry data TLB
- Max issue rate of one 32x16 multiply per clock
- Max issue rate of one 32x32 multiply every other clock
- CPU control with start, stop and single stepping
- Software breakpoints support
- Hardware breakpoints on virtual addresses
- Enhanced JTAG and ICE Interface that is compatible with v2.5 of the EJTAG Specification

◆ DDR Memory Controller

- Supports up to 2GB of DDR SDRAM
- 2 chip selects (each chip select supports 4 internal DDR banks)
- Supports 16-bit or 32-bit data bus width using 8, 16, or 32-bit devices
- Supports 64Mb, 128Mb, 256Mb, 512Mb, and 1Gb DDR SDRAM devices
- Data bus multiplexing support allows interfacing to standard DDR DIMMs and SODIMMs
- Automatic refresh generation

◆ Memory and Peripheral Device Controller

- Provides “glueless” interface to standard SRAM, Flash, ROM, dual-port memory, and peripheral devices
- Demultiplexed address and data buses: 16-bit data bus, 26-bit address bus, 6 chip selects, supports alternate bus masters, control for external data bus buffers
- Supports 8-bit and 16-bit width devices
- Automatic byte gathering and scattering
- Flexible protocol configuration parameters: programmable number of wait states (0 to 63), programmable postread/post-write delay (0 to 31), supports external wait state generation, supports Intel and Motorola style peripherals
- Write protect capability per chip select
- Programmable bus transaction timer generates warm reset when counter expires
- Supports up to 64 MB of memory per chip select

◆ Counter/Timers

- Three general purpose 32-bit counter timers

◆ PCI Interface

- 32-bit PCI revision 2.2 compliant (3.3V only)
- Supports host or satellite operation in both master and target modes
- Support for synchronous and asynchronous operation
- PCI clock supports frequencies from 16 MHz to 66 MHz
- PCI arbiter in Host mode: supports 6 external masters, fixed priority or round robin arbitration
- I₂O “like” PCI Messaging Unit

Block Diagram

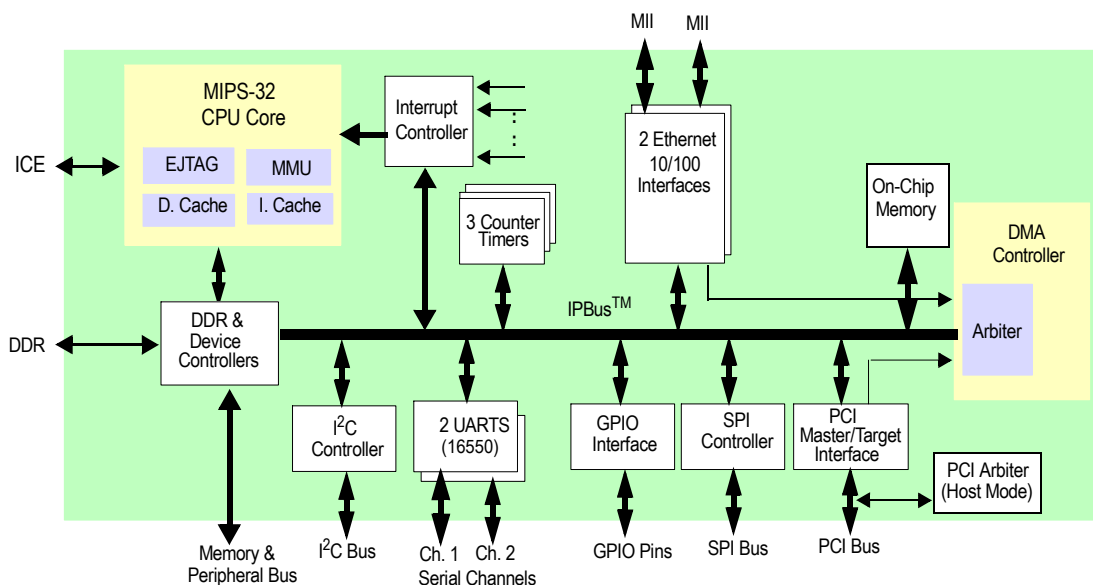

- ◆ **DMA Controller**
 - 10 DMA channels: two channels for PCI (PCI to Memory and Memory to PCI), two for each Ethernet interface, two channels for memory to memory operations, two channels for external operations
 - Provides flexible descriptor based operation
 - Supports unaligned transfers (i.e., source or destination address may be on any byte boundary) with arbitrary byte length.
- ◆ **Two Ethernet Interfaces**
 - 10 and 100 Mb/s ISO/IEC 8802-3:1996 compliant
 - Two IEEE 802.3u compatible Media Independent Interfaces (MII) with serial management interface
 - MII supports IEEE 802.3u auto-negotiation speed selection
 - Supports 64 entry hash table based multicast address filtering
 - 512 byte transmit and receive FIFOs
 - Supports flow control functions outlined in IEEE Std. 802.3x-1997
- ◆ **Universal Asynchronous Receiver Transmitter (UART)**
 - Compatible with the 16550 and 16450 UARTs
 - Two completely separate serial channels
 - Modem control functions (CTS, RTS, DSR, DTR, RI, DCD)
 - 16-byte transmit and receive buffers
 - Programmable baud rate generator derived from the system clock
 - Fully programmable serial characteristics:
 - 5, 6, 7, or 8 bit characters
 - Even, odd or no parity bit generation and detection
 - 1, 1-1/2 or 2 stop bit generation
 - Line break generation and detection
 - False start bit detection
 - Internal loopback mode
- ◆ **I²C-Bus**
 - Supports standard 100 Kbps mode as well as 400 Kbps fast mode
 - Supports 7-bit and 10-bit addressing
 - Supports four modes: master transmitter, master receiver, slave transmitter, slave receiver
- ◆ **Additional General Purpose Peripherals**
 - Two 16550-compatible serial ports
 - Interrupt controller
 - System integrity functions
 - General purpose I/O controller
 - Serial peripheral interface (SPI)
- ◆ **On-chip Memory**
 - 4KB of high speed SRAM organized as 1K x 32 bits
 - Supports burst and non-burst byte, halfword, triple-byte, and word CPU, PCI, and DMA accesses
- ◆ **Debug Support**
 - Rev. 2.6 compliant EJTAG Interface

Device Overview

The RC32438 is a member of the IDT™ Interprise™ family of PCI integrated communications processors. It incorporates a high performance CPU core and a number of on-chip peripherals. The integrated processor is designed to transfer information from I/O modules to main

memory with minimal CPU intervention using a highly sophisticated direct memory access (DMA) engine. All data transfers through the RC32438 are achieved by writing data from an on-chip I/O peripheral to main memory and then out to another I/O module.

CPU Execution Core

The 32-bit CPU core is 100% compatible with the MIPS32 instruction set architecture (ISA).

Specifically, this device features the 4Kc CPU core developed by MIPS Technologies Inc. (www.mips.com). This core issues a single instruction per cycle, includes a five stage pipeline, and is optimized for applications that require integer arithmetic. The CPU core includes 16 KB instruction and 16 KB data caches. Both caches are 4-way set associative and can be locked on a per line basis, which allows the programmer control over this precious on-chip memory resource. The core also features a memory management unit (MMU). The CPU core also incorporates an enhanced joint test access group (EJTAG) interface that is used to interface to in-circuit emulator tools, providing access to internal registers and enabling the part to be controlled externally, simplifying the system debug process. The use of this core allows IDT's customers to leverage the broad range of software and development tools available for the MIPS architecture, including operating systems, compilers, and in-circuit emulators.

Double Data Rate Memory Controller

The RC32438 incorporates a high performance double data rate (DDR) memory controller which supports both x16 and x32 memory configurations up to 2GB. This module provides all of the signals required to interface to both memory modules and discrete devices, including two chip selects, differential clocking outputs and data strobes.

Memory and I/O Controller

The RC32438 uses a dedicated local memory/I/O controller including a de-multiplexed 16-bit data and 26-bit address bus. It includes all of the signals required to interface directly to as many as six Intel or Motorola-style external peripherals, and the interface can be configured to support both 8-bit and 16-bit peripherals.

DMA Controller

The DMA controller consists of 10 independent DMA channels, all of which operate in exactly the same manner. The DMA controller off-loads the CPU core from moving data among the on-chip interfaces, external peripherals, and memory. The controller supports scatter/gather DMA with no alignment restrictions, appropriate for communications and graphics systems.

PCI Interface

The PCI interface on the RC32438 is compatible with version 2.2 of the PCI specification. An on-chip arbiter supports up to six external bus masters, supporting both fixed priority and rotating priority arbitration schemes. The part can support both satellite and host PCI configurations, enabling the RC32438 to act as a slave controller for a PCI add-in

card application, or as the primary PCI controller in the system. The PCI interface can be operated synchronously or asynchronously to the other I/O interfaces on the RC32438 device.

Ethernet Interface

The RC32438 has two Ethernet Channels supporting 10Mbps and 100Mbps speeds to provide a standard media independent interface (MII) off-chip, allowing a wide range of external devices to be connected efficiently.

UART Interface

The RC32438 contains two completely separate serial channels (UARTs) that are compatible with the industry standard 16550 UART.

System Integrity Functions

The RC32438 contains a programmable watchdog timer that generates NMI when the counter expires and an address space monitor that reports errors in response to accesses to undecoded address regions.

General Purpose I/O Controller

The RC32438 contains 32 general purpose input/output pins. Each pin may be used as an active high or active low level interrupt or non-maskable interrupt input, and each signal may be used as a bit input or output port.

I²C Interface

The standard I2C interface allows the RC32438 to connect to a number of standard external peripherals for a more complete system solution. The RC32438 supports both master and slave operations.

Debug Support

The RC32438 supports the industry standard Rev. 2.6 EJTAG interface.

Thermal Considerations

The RC32438 consumes less than 2.7 W peak power. It is guaranteed in a ambient temperature range of 0° to +70° C for commercial temperature devices and - 40° to +85° for industrial temperature devices.

Revision History

November 7, 2002: Initial publication. Preliminary Information.

November 15, 2002: Added footnotes to Tables 5, 9, and 10.

December 12, 2002: Added Clock Speed parameter to PLL and Core supply in Table 16.

December 19, 2002: Release version.

January 13, 2003: Changed Thermal Considerations to read less than 2.7W instead of 2.5W, added values to CLK parameter in Table 5, and revised EJTAG description.

February 4, 2003: Revised description for EJTAG/JTAG pins in Table 1. Changed DDRDM[7:0] from input/output to output only in Tables 1 and 2 and Logic Diagram. Added new section, Voltage Sense Signal Timing, as part of EJTAG description.

March 4, 2003: In Table 2, removed “pull-up” from PCI pin category and from GPIO [24] and GPIO[30-26]. In Table 20, changed max. values for VccSI/O, VccCore, and VccPLL.

July 9, 2003: In Table 7: changed values for DDRDATA, DDRDM, and DDRADDR—WEN signals, and deleted old footnote #3 and changed values in new footnote #3. In Table 8, changed Tdo values. Changed Figure 7. Changed values in Table 18, Power Consumption. Removed IPBus Monitor feature which included changes to Tables 1, 2, 21, 24, and 25. Deleted Table 13 which resulted in a re-ordering of subsequent tables.

March 8, 2004: Added 300MHz speed grade.

May 25, 2004: In Table 9, signals MIIxRXCLK and MIIxTXCLK, the Min and Max values for Thigh/Tlow_9c were changed to 140 and 260 respectively and the Min and Max values for Thigh/Tlow_9d were changed to 14.0 and 26.0 respectively.

Pin Description Table

The following table lists the functions of the pins provided on the RC32438. Some of the functions listed may be multiplexed onto the same pin.

The active polarity of a signal is defined using a suffix. Signals ending with an "N" are defined as being active, or asserted, when at a logic zero (low) level. All other signals (including clocks, buses and select lines) will be interpreted as being active, or asserted when at a logic one (high) level.

Signal	Type	Name/Description
System		
CLK	I	Master Clock. This is the master clock input. The processor frequency is a multiple of this clock frequency. This clock is used as the system clock for all memory and peripheral bus operations.
EXTCLK	O	External Clock. This clock is used for all memory and peripheral bus operations.
COLDRSTN	I	Cold Reset. The assertion of this signal initiates a cold reset. This causes the processor state to be initialized, boot configuration to be loaded, and the internal PLL to lock onto the master clock (CLK).
RSTN	I/O	Reset. The assertion of this bidirectional signal initiates a warm reset. This signal is asserted by the RC32438 during a warm reset.
Memory and Peripheral Bus		
BDIRN	O	External Buffer Direction. Memory and peripheral bus external data bus buffer direction control. If the RC32438 memory and peripheral bus is connected to the A side of a transceiver, such as an IDT74FCT245, then this pin may be directly connected to the direction control (e.g., BDIR) pin of the transceiver.
BGN	O	Bus Grant. This signal is asserted by the RC32438 to indicate that the RC32438 has relinquished ownership of the memory and peripheral bus.
BOEN	O	External Buffer Enable. This signal provides an output enable control for an external buffer on the memory and peripheral data bus.
BRN	I	Bus Request. This signal is asserted by an external device to request ownership of the memory and peripheral bus.
BWEN[1:0]	O	Byte Write Enables. These signals are memory and peripheral bus byte write enable signals. BWEN[0] corresponds to byte lane MDATA[7:0] BWEN[1] corresponds to byte lane MDATA[15:8]
CSN[5:0]	O	Chip Selects. These signals are used to select an external device on the memory and peripheral bus.
MADDR[21:0]	O	Address Bus. 22-bit memory and peripheral bus address bus. MADDR[25:22] are available as GPIO alternate functions
MDATA[15:0]	I/O	Data Bus. 16-bit memory and peripheral data bus. During a cold reset, these pins function as inputs that are used to load the boot configuration vector.
OEN	O	Output Enable. This signal is asserted when data should be driven on by an external device on the memory and peripheral bus.
RWN	O	Read Write. This signal indicates if the transaction on the memory and peripheral bus is a read transaction or a write transaction. A high level indicates a read from an external device. A low level indicates a write to an external device.

Table 1 Pin Description (Part 1 of 9)

Signal	Type	Name/Description
WAITACKN	I	Wait or Transfer Acknowledge. When configured as wait, this signal is asserted during a memory and peripheral bus transaction to extend the bus cycle. When configured as a transfer acknowledge, this signal is asserted during a transaction to signal the completion of the transaction.
DDR Bus		
DDRADDR[13:0]	O	DDR Address Bus. 14-bit multiplexed DDR bus address bus. This bus is used to transfer the addresses to the DDR devices.
DDRBA[1:0]	O	DDR Bank Address. These signals are used to transfer the bank address to the DDRs.
DDRCASN	O	DDR Column Address Strobe. This signal is asserted during DDR transactions.
DDRCKE	O	DDR Clock Enable. The DDR clock enable is asserted during normal DDR operation. This signal is negated during following a cold reset or during a power down operation.
DDRCKN[1:0]	O	DDR Negative DDR clock. These signals are the negative clock of the differential DDR clock pair. Two copies of this output are provided to reduce signal loading.
DDRCKP[1:0]	O	DDR Positive DDR clock. These signals are the positive clock of the differential DDR clock pair. Two copies of this output are provided to reduce signal loading.
DDRCASN[1:0]	O	DDR Chip Selects. These active low signals are used to select DDR device(s) on the DDR bus.
DDRDATA[31:0]	I/O	DDR Data Bus. 32-bit DDR data bus used to transfer data between the RC32438 and the DDR devices. Data is transferred on both edges of the clock.
DDRDM[7:0]	O	DDR Data Write Enables. Byte data write enables used to enable specific byte lanes during DDR writes. DDRDM[0] corresponds to DDRDATA[7:0] DDRDM[1] corresponds to DDRDATA[15:8] DDRDM[2] corresponds to DDRDATA[23:16] DDRDM[3] corresponds to DDRDATA[31:24] DDRDM[4] corresponds to DDRDATA[39:32] DDRDM[5] corresponds to DDRDATA[47:40] DDRDM[6] corresponds to DDRDATA[55:48] DDRDM[7] corresponds to DDRDATA[54:56] (Refer to the DDR Data Bus Multiplexing section in Chapter 7 of the RC32438 User Reference Manual.)
DDRQSQ[3:0]	I/O	DDR Data Strobes. DDR byte data strobes used to clock data between DDR devices and the RC32438. These strobes are inputs during DDR reads and outputs during DDR writes. DDRQSQ[0] corresponds to DDRDATA[7:0]. DDRQSQ[1] corresponds to DDRDATA[15:8]. DDRQSQ[2] corresponds to DDRDATA[23:16]. DDRQSQ[3] corresponds to DDRDATA[31:24].
DDROEN[3:0]	O	DDR Bus Switch Output Enables. These pins are used to enable external data bus switches in systems that support data bus multiplexing.
DDRRASN	O	DDR Row Address Strobe. The DDR row address strobe is asserted during DDR transactions.

Table 1 Pin Description (Part 2 of 9)

Signal	Type	Name/Description
DDRVREF	I	DDR Voltage Reference. SSTL_2 DDR voltage reference generated by an external source.
DDRWEN	O	DDR Write Enable. DDR write enable is asserted during DDR write transactions.
PCI Bus		
PCIAD[31:0]	I/O	PCI Multiplexed Address/Data Bus. Address is driven by a bus master during initial PCIFRAMEN assertion. Data is then driven by the bus master during writes or by the bus target during reads.
PCICBEN[3:0]	I/O	PCI Multiplexed Command/Byte Enable Bus. PCI command is driven by the bus master during the initial PCIFRAMEN assertion. Byte enable signals are driven by the bus master during subsequent data phase(s).
PCICLK	I	PCI Clock. Clock used for all PCI bus transactions.
PCIDEVSELN	I/O	PCI Device Select. This signal is driven by a bus target to indicate that the target has decoded the address as one of its own address spaces.
PCIFRAMEN	I/O	PCI Frame. Driven by a bus master. Assertion indicates the beginning of a bus transaction. Negation indicates the last data.
PCIGNTN[3:0]	I/O	<p>PCI Bus Grant.</p> <p>In PCI host mode with internal arbiter: The assertion of these signals indicates to the agent that the internal RC32438 arbiter has granted the agent access to the PCI bus.</p> <p>In PCI host mode with external arbiter: PCIGNTN[0]: asserted by an external arbiter to indicate to the RC32438 that access to the PCI bus has been granted. PCIGNTN[3:1]: unused and driven high.</p> <p>In PCI satellite mode: PCIGNTN[0]: This signal is asserted by an external arbiter to indicate to the RC32438 that access to the PCI bus has been granted. PCIGNTN[1]: this signal takes on the alternate function of PCIEECS and is used as a PCI Serial EEPROM chip select PCIGNTN[3:2]: unused and driven high.</p> <p>Note: When the GPIO register is programmed in the alternate function mode for bits GPIO [26] and [28], these bits become PCIGNTN [4] and [5] respectively.</p>
PCIIRDYN	I/O	PCI Initiator Ready. Driven by the bus master to indicate that the current datum can complete.
PCILOCKN	I/O	PCI Lock. This signal is asserted by an external bus master to indicate that an exclusive operation is occurring.
PCIPAR	I/O	PCI Parity. Even parity of the PCIAD[31:0] bus. Driven by the bus master during address and write Data phases. Driven by the bus target during the read data phase.
PCIPERRN	I/O	PCI Parity Error. If a parity error is detected, this signal is asserted by the receiving bus agent 2 clocks after the data is received.

Table 1 Pin Description (Part 3 of 9)

Signal	Type	Name/Description
PCIREQN[3:0]	I/O	<p>PCI Bus Request.</p> <p>In PCI host mode with internal arbiter: These signals are inputs whose assertion indicates to the internal RC32438 arbiter that an agent desires ownership of the PCI bus.</p> <p>In PCI host mode with external arbiter: PCIREQN[0]: asserted by the RC32438 to request ownership of the PCI bus. PCIREQN[3:1]: unused and driven high.</p> <p>In PCI satellite mode: PCIREQN[0]: this signal is asserted by the RC32438 to request use of the PCI bus. PCIREQN[1]: function changes to PCIIDSEL and is used as a chip select during configuration read and write transactions. PCIREQN[3:2]: unused and driven high.</p> <p>Note: When the GPIO register is programmed in the alternate function mode for bits GPIO [24] and [27], these bits become PCIREQN [4] and [5] respectively.</p>
PCIRSTN	I/O	<p>PCI Reset. In host mode, this signal is asserted by the RC32438 to generate a PCI reset. In satellite mode, assertion of this signal initiates a warm reset.</p>
PCISERRN	I/O	<p>PCI System Error. This signal is driven by an agent to indicate an address parity error, data parity error during a special cycle command, or any other system error. Requires an external pull-up.</p>
PCISTOPN	I/O	<p>PCI Stop. Driven by the bus target to terminate the current bus transaction. For example, to indicate a retry.</p>
PCITRDYN	I/O	<p>PCI Target Ready. Driven by the bus target to indicate that the current data can complete.</p>
General Purpose Input/Output		
GPIO[0]	I/O	<p>General Purpose I/O. This pin can be configured as a general purpose I/O pin. Alternate function pin name: U0SOUT Alternate function: UART channel 0 serial output.</p>
GPIO[1]	I/O	<p>General Purpose I/O. This pin can be configured as a general purpose I/O pin. Alternate function pin name: U0SINP Alternate function: UART channel 0 serial input.</p>
GPIO[2]	I/O	<p>General Purpose I/O. This pin can be configured as a general purpose I/O pin. Alternate function pin name: U0RIN Alternate function: UART channel 0 ring indicator input.</p>
GPIO[3]	I/O	<p>General Purpose I/O. This pin can be configured as a general purpose I/O pin. Alternate function pin name: U0DCDN Alternate function: UART channel 0 data carrier detect input.</p>
GPIO[4]	I/O	<p>General Purpose I/O. This pin can be configured as a general purpose I/O pin. Alternate function pin name: U0DTRN Alternate function: UART channel 0 data terminal ready input.</p>
GPIO[5]	I/O	<p>General Purpose I/O. This pin can be configured as a general purpose I/O pin. Alternate function pin name: U0DSRN Alternate function: UART channel 0 data set ready input.</p>

Table 1 Pin Description (Part 4 of 9)

Signal	Type	Name/Description
GPIO[6]	I/O	General Purpose I/O. This pin can be configured as a general purpose I/O pin. Alternate function pin name: U0RTSN Alternate function: UART channel 0 request to send output.
GPIO[7]	I/O	General Purpose I/O. This pin can be configured as a general purpose I/O pin. Alternate function pin name: U0CTSN Alternate function: UART channel 0 clear to send input.
GPIO[8]	I/O	General Purpose I/O. This pin can be configured as a general purpose I/O pin. Alternate function pin name: U1SOUT Alternate function: UART channel 1 serial output.
GPIO[9]	I/O	General Purpose I/O. This pin can be configured as a general purpose I/O pin. Alternate function pin name: U1SINP Alternate function: UART channel 1 serial input.
GPIO[10]	I/O	General Purpose I/O. This pin can be configured as a general purpose I/O pin. Alternate function pin name: U1DTRN Alternate function: UART channel 1 data terminal ready output.
GPIO[11]	I/O	General Purpose I/O. This pin can be configured as a general purpose I/O pin. Alternate function pin name: U1DSRN Alternate function: UART channel 1 data set ready input.
GPIO[12]	I/O	General Purpose I/O. This pin can be configured as a general purpose I/O pin. Alternate function pin name: U1RTSN Alternate function: UART channel 1 request to send output.
GPIO[13]	I/O	General Purpose I/O. This pin can be configured as a general purpose I/O pin. Alternate function pin name: U1CTSN Alternate function: UART channel 1 clear to send input.
GPIO[14]	I/O	General Purpose I/O. This pin can be configured as a general purpose I/O pin. Alternate function pin name: DMAREQN0 Alternate function: External DMA channel 0 request input.
GPIO[15]	I/O	General Purpose I/O. This pin can be configured as a general purpose I/O pin. Alternate function pin name: DMAREQN1 Alternate function: External DMA channel 1 request input.
GPIO[16]	I/O	General Purpose I/O. This pin can be configured as a general purpose I/O pin. Alternate function pin name: DMADONEN0 Alternate function: External DMA channel 0 done input.
GPIO[17]	I/O	General Purpose I/O. This pin can be configured as a general purpose I/O pin. Alternate function pin name: DMADONEN1 Alternate function: External DMA channel 1 done input.

Table 1 Pin Description (Part 5 of 9)

Signal	Type	Name/Description
GPIO[18]	I/O	General Purpose I/O. This pin can be configured as a general purpose I/O pin. Alternate function pin name: DMAFINN0 Alternate function: External DMA channel 0 finished output.
GPIO[19]	I/O	General Purpose I/O. This pin can be configured as a general purpose I/O pin. Alternate function pin name: DMAFINN1 Alternate function: External DMA channel 1 finished output.
GPIO[20]	I/O	General Purpose I/O. This pin can be configured as a general purpose I/O pin Alternate function pin name: MADDR[22] Alternate function: Memory and peripheral bus address output.
GPIO[21]	I/O	General Purpose I/O. This pin can be configured as a general purpose I/O pin. Alternate function pin name: MADDR[23] Alternate function: Memory and peripheral bus address output.
GPIO[22]	I/O	General Purpose I/O. This pin can be configured as a general purpose I/O pin. Alternate function pin name: MADDR[24] Alternate function: Memory and peripheral bus address output.
GPIO[23]	I/O	General Purpose I/O. This pin can be configured as a general purpose I/O pin. Alternate function pin name: MADDR[25] Alternate function: Memory and peripheral bus address output.
GPIO[24]	I/O	General Purpose I/O. This pin can be configured as a general purpose I/O pin. Alternate function pin name: PCIREQN[4] Alternate function: PCI Request 4 input or output.
GPIO[25]	I/O	General Purpose I/O. This pin can be configured as a general purpose I/O pin. Alternate function pin name: AFSPARE1 Alternate function: <i>reserved.</i>
GPIO[26]	I/O	General Purpose I/O. This pin can be configured as a general purpose I/O pin. Alternate function pin name: PCIGNTN[4] Alternate function: PCI Grant 4 output.
GPIO[27]	I/O	General Purpose I/O. This pin can be configured as a general purpose I/O pin. Alternate function pin name: PCIREQN[5] Alternate function: PCI Request 5 input or output.
GPIO[28]	I/O	General Purpose I/O. This pin can be configured as a general purpose I/O pin. Alternate function pin name: PCIGNTN[5] Alternate function: PCI Grant 5 output.
GPIO[29]	I/O	General Purpose I/O. This pin can be configured as a general purpose I/O pin. Alternate function pin name: Reserved Alternate function: Reserved.

Table 1 Pin Description (Part 6 of 9)

Signal	Type	Name/Description
GPIO[30]	I/O	General Purpose I/O. This pin can be configured as a general purpose I/O pin. Alternate function pin name: PCIMUINTN Alternate function: PCI Messaging unit interrupt output.
GPIO[31]	I/O	General Purpose I/O. This pin can be configured as a general purpose I/O pin.
SPI Interface		
SCK	I/O	Serial Clock. This signal is used as the serial clock output in SPI mode and in PCI satellite mode with suspended CPU execution during PCI serial EEPROM loading. This pin may be configured as a GPIO pin.
SDI	I/O	Serial Data Input. This signal is used to shift in serial data in SPI mode and in PCI satellite mode with suspended CPU execution during PCI serial EEPROM loading. This pin may be configured as a GPIO pin.
SDO	I/O	Serial Data Output. This signal is used shift out serial data in SPI mode and in PCI satellite mode with suspended CPU execution during PCI serial EEPROM loading. This pin may be configured as a GPIO pin.
I²C Bus Interface		
SCL	I/O	I²C Clock. I ² C-bus clock.
SDA	I/O	I²C Data Bus. I ² C-bus data bus.
Ethernet Interfaces		
MII0CL	I	Ethernet 0 MII Collision Detected. This signal is asserted by the ethernet PHY when a collision is detected.
MII0CRS	I	Ethernet 0 MII Carrier Sense. This signal is asserted by the ethernet PHY when either the transmit or receive medium is not idle.
MII0RXCLK	I	Ethernet 0 MII Receive Clock. This clock is a continuous clock that provides a timing reference for the reception of data.
MII0RXD[3:0]	I	Ethernet 0 MII Receive Data. This nibble wide data bus contains the data received by the ethernet PHY.
MII0RXDV	I	Ethernet 0 MII Receive Data Valid. The assertion of this signal indicates that valid receive data is in the MII receive data bus.
MII0RXER	I	Ethernet 0 MII Receive Error. The assertion of this signal indicates that an error was detected somewhere in the ethernet frame currently being sent in the MII receive data bus.
MII0TXCLK	I	Ethernet 0 MII Transmit Clock. This clock is a continuous clock that provides a timing reference for the transfer of transmit data.
MII0TXD[3:0]	O	Ethernet 0 MII Transmit Data. This nibble wide data bus contains the data to be transmitted.
MII0TXENP	O	Ethernet 0 MII Transmit Enable. The assertion of this signal indicates that data is present on the MII for transmission.
MII0TXER	O	Ethernet 0 MII Transmit Coding Error. When this signal is asserted together with MII0TXENP, the ethernet PHY will transmit symbols which are not valid data or delimiters.
MII1CL	I	Ethernet 1 MII Collision Detected. This signal is asserted by the ethernet PHY when a collision is detected.

Table 1 Pin Description (Part 7 of 9)

Signal	Type	Name/Description
MII1CRS	I	Ethernet 1 MII Carrier Sense. This signal is asserted by the ethernet PHY when either the transmit or receive medium is not idle.
MII1RXCLK	I	Ethernet 1 MII Receive Clock. This clock is a continuous clock that provides a timing reference for the reception of data.
MII1RXD[3:0]	I	Ethernet 1 MII Receive Data. This nibble wide data bus contains the data received by the ethernet PHY.
MII1RXDV	I	Ethernet 1 MII Receive Data Valid. The assertion of this signal indicates that valid receive data is in the MII receive data bus.
MII1RXER	I	Ethernet 1 MII Receive Error. The assertion of this signal indicates that an error was detected somewhere in the ethernet frame currently being sent in the MII receive data bus.
MII1TXCLK	I	Ethernet 1 MII Transmit Clock. This clock is a continuous clock that provides a timing reference for the transfer of transmit data.
MII1TXD[3:0]	O	Ethernet 1 MII Transmit Data. This nibble wide data bus contains the data to be transmitted.
MII1TXENP	O	Ethernet 1 MII Transmit Enable. The assertion of this signal indicates that data is present on the MII for transmission.
MII1TXER	O	Ethernet 1 MII Transmit Coding Error. When this signal is asserted together with MIITXENP, the ethernet PHY will transmit symbols which are not valid data or delimiters.
MIIMDC	O	MII Management Data Clock. This signal is used as a timing reference for transmission of data on the management interface.
MIIMDIO	I/O	MII Management Data. This bidirectional signal is used to transfer data between the station management entity and the ethernet PHY.
JTAG / EJTAG		
EJTAG_TMS	I	EJTAG Mode. The value on this signal controls the test mode select of the EJTAG Controller. When using the JTAG boundary scan, this pin should be left disconnected (since there is an internal pull-up) or driven high.
JTAG_TCK	I	JTAG Clock. This is an input test clock used to clock the shifting of data into or out of the boundary scan logic, JTAG Controller, or the EJTAG Controller. JTAG_TCK is independent of the system and the processor clock with a nominal 50% duty cycle.
JTAG_TDI	I	JTAG Data Input. This is the serial data input to the boundary scan logic, JTAG Controller, or the EJTAG Controller.
JTAG_TDO	O	JTAG Data Output. This is the serial data shifted out from the boundary scan logic, JTAG Controller, or the EJTAG Controller. When no data is being shifted out, this signal is tri-stated.
JTAG_TMS	I	JTAG Mode. The value on this signal controls the test mode select of the boundary scan logic or JTAG Controller. When using the EJTAG debug interface, this pin should be left disconnected (since there is an internal pull-up) or driven high.

Table 1 Pin Description (Part 8 of 9)

Signal	Type	Name/Description
JTAG_TRST_N	I	JTAG Reset. This active low signal asynchronously resets the boundary scan logic, JTAG TAP Controller, and the EJTAG Debug TAP Controller. An external pull-up on the board is recommended to meet the JTAG specification in cases where the tester can access this signal. However, for systems running in functional mode, one of the following should occur: 1) actively drive this signal low with control logic 2) statically drive this signal low with an external pull-down on the board 3) clock JTAG_TCK while holding EJTAG_TMS and/or JTAG_TMS high.
Debug		
CPU	O	CPU Transaction. This signal is asserted during all CPU instruction fetches and data transfers to/from the DDR and devices on the memory and peripheral bus. The signal is negated during PCI and DMA transactions to/from the DDR and devices on the memory and peripheral bus.
INST	O	Instruction or Data. This signal is driven high during CPU instruction fetches on the memory and peripheral bus memory or DDR bus.

Table 1 Pin Description (Part 9 of 9)

Pin Characteristics

Note: Some input pads of the RC32438 do not contain internal pull-ups or pull-downs. Unused inputs should be tied off to appropriate levels. This is especially critical for unused control signal inputs (such as BRN) which, if left floating, could adversely affect the RC32438's operation. Also, any input pin left floating can cause a slight increase in power consumption.

Function	Pin Name	Type	Buffer	I/O Type	Internal Resistor	Notes ¹
Memory and Peripheral Bus	BDIRN	O	LVTTTL	High Drive		
	BGN	O	LVTTTL	Low Drive		
	BOEN	O	LVTTTL	High Drive		
	BRN	I	LVTTTL	STI ²	pull-up	
	BWEN[1:0]	O	LVTTTL	High Drive		
	CSN[5:0]	O	LVTTTL	High Drive		
	MADDR[21:0]	O	LVTTTL	High Drive		
	MDATA[15:0]	I/O	LVTTTL	High Drive		
	OEN	O	LVTTTL	High Drive		
	RWN	O	LVTTTL	High Drive		
	WAITACKN	I	LVTTTL	STI	pull-up	

Table 2 Pin Characteristics (Part 1 of 4)

Function	Pin Name	Type	Buffer	I/O Type	Internal Resistor	Notes ¹
DDR Bus	DDRADDR[13:0]	O	SSTL_2	SSTL_2		
	DDRBA[1:0]	O	SSTL_2	SSTL_2		
	DDRCASN	O	SSTL_2	SSTL_2		
	DDRCKE	O	SSTL_2 / LVCMOS	SSTL_2		
	DDRCKN[1:0]	O	SSTL_2	SSTL_2		
	DDRCKP[1:0]	O	SSTL_2	SSTL_2		
	DDRCASN	O	SSTL_2	SSTL_2		
	DDRDATA[31:0]	I/O	SSTL_2	SSTL_2		
	DDRDM[7:0]	O	SSTL_2	SSTL_2		
	DDRQDS[3:0]	I/O	SSTL_2	SSTL_2		
	DDROEN[3:0]	O	SSTL_2	SSTL_2		
	DDRRASN	O	SSTL_2	SSTL_2		
	DDRVREF	I	Analog	SSTL_2		
	DDRWEN	O	SSTL_2	SSTL_2		
PCI Bus Interface ³	PCIAID[31:0]	I/O	PCI	PCI		
	PCICBEN[3:0]	I/O	PCI	PCI		
	PCICLK	I	PCI	PCI		
	PCIDEVSELN	I/O	PCI	PCI		pull-up on board
	PCIFRAMEN	I/O	PCI	PCI		pull-up on board
	PCIGNTN[3:0]	I/O	PCI	PCI		pull-up on board
	PCIIRDYN	I/O	PCI	PCI		pull-up on board
	PCILOCKN	I/O	PCI	PCI		
	PCIPAR	I/O	PCI	PCI		
	PCIPERRN	I/O	PCI	PCI		
	PCIREQN[3:0]	I/O	PCI	PCI		pull-up on board
	PCIRSTN	I/O	PCI	PCI		pull-down on board
	PCISERRN	I/O	PCI	Open Collector; PCI		pull-up on board
	PCISTOPN	I/O	PCI	PCI		pull-up on board
	PCITRDYN	I/O	PCI	PCI		pull-up on board
General Purpose I/O	GPIO[23:0]	I/O	LVTTTL	Low Drive	pull-up	
	GPIO[24]	I/O	PCI			pull-up on board
	GPIO[25]	I/O	LVTTTL	Low Drive	pull-up	
	GPIO[30:26] ⁴	I/O	PCI			pull-up on board
	GPIO[31]	I/O	LVTTTL	Low Drive	pull-up	

Table 2 Pin Characteristics (Part 2 of 4)

Function	Pin Name	Type	Buffer	I/O Type	Internal Resistor	Notes ¹
Serial Interface	SCK	I/O	LVTTTL	Low Drive	pull-up	pull-up on board
	SDI	I/O	LVTTTL	Low Drive	pull-up	pull-up on board
	SDO	I/O	LVTTTL	Low Drive	pull-up	pull-up on board
I ² C-Bus Interface	SCL	I/O	LVTTTL	Low Drive/STI		pull-up on board ⁵
	SDA	I/O	LVTTTL	Low Drive/STI		pull-up on board ⁵
Ethernet Interfaces	MII0CL	I	LVTTTL	STI	pull-down	
	MII0CRS	I	LVTTTL	STI	pull-down	
	MII0RXCLK	I	LVTTTL	STI	pull-up	
	MII0RXD[3:0]	I	LVTTTL	STI	pull-up	
	MII0RXDV	I	LVTTTL	STI	pull-down	
	MII0RXER	I	LVTTTL	STI	pull-down	
	MII0TXCLK	I	LVTTTL	STI	pull-up	
	MII0TXD[3:0]	O	LVTTTL	Low Drive		
	MII0TXENP	O	LVTTTL	Low Drive		
	MII0TXER	O	LVTTTL	Low Drive		
	MII1CL	I	LVTTTL	STI	pull-down	
	MII1CRS	I	LVTTTL	STI	pull-down	
	MII1RXCLK	I	LVTTTL	STI	pull-up	
	MII1RXD[3:0]	I	LVTTTL	STI	pull-up	
	MII1RXDV	I	LVTTTL	STI	pull-down	
	MII1RXER	I	LVTTTL	STI	pull-down	
	MII1TXCLK	I	LVTTTL	STI	pull-up	
	MII1TXD[3:0]	O	LVTTTL	Low Drive		
	MII1TXENP	O	LVTTTL	Low Drive		
	MII1TXER	O	LVTTTL	Low Drive		
MIIMDC	O	LVTTTL	Low Drive			
MIIMDIO	I/O	LVTTTL	Low Drive	pull-up		
EJTAG / ICE	JTAG_TRST_N	I	LVTTTL	STI	pull-up	
	JTAG_TCK	I	LVTTTL	STI	pull-up	
	JTAG_TDI	I	LVTTTL	STI	pull-up	
	JTAG_TDO	O	LVTTTL	Low Drive		
	JTAG_TMS	I	LVTTTL	STI	pull-up	
	EJTAG_TMS	I	LVTTTL	STI	pull-up	
Debug	CPU	O	LVTTTL	Low Drive		
	INST	O	LVTTTL	Low Drive		

Table 2 Pin Characteristics (Part 3 of 4)

Function	Pin Name	Type	Buffer	I/O Type	Internal Resistor	Notes ¹
Miscellaneous	CLK	I	LVTTL	STI		
	EXTCLK	O	LVTTL	High Drive		
	COLDRSTN	I	LVTTL	STI		
	RSTN	I/O	LVTTL	Low Drive / STI	pull-up	pull-up on board

Table 2 Pin Characteristics (Part 4 of 4)

- ¹ External pull-up required in most system applications. Some applications may require additional pull-ups not identified in this table.
- ² Schmidt Trigger Input (STI).
- ³ The PCI pins have internal pull-ups but they are too weak to guarantee system validity. Therefore, board pull-ups are mandatory where indicated. GPIO alternate function pins for PCI must also have board pull-ups.
- ⁴ PCIMUINTN is an alternate function of GPIO[30]. When configured as an alternate function, this pin is tri-stated when not asserted (i.e., it acts as an open collector output).
- ⁵ Use a 2.2K pull-up resistor for I2C pins.

Boot Configuration Vector

The boot configuration vector is read by the RC32438 during a cold reset. The vector defines essential RC32438 parameters that are required once the cold reset completes.

The encoding of the boot configuration vector is described in Table 3, and the vector input is illustrated in Figure 4. The value of the boot configuration vector read in by the RC32438 during a cold reset may be determined by reading the Boot Configuration Vector (BCV) Register.

Signal	Name/Description
MDATA[3:0]	<p>CPU Pipeline Clock Multiplier. This field specifies the value by which the PLL multiplies the master clock input (CLK) to obtain the processor clock frequency (PCLK). For master clock input frequency constraints, refer to Table 3.1 in the RC32438 User Manual.</p> <p>0x0 - PLL Bypass 0x1 - Multiply by 3 0x2 - Multiply by 4 0x3 - Multiply by 6 0x4 - Multiply by 8 0x5 - reserved 0x6 - reserved 0x7 - reserved 0x8 - reserved 0xD - reserved 0xE - reserved 0xF - reserved</p>
MDATA[5:4]	<p>External Clock Divider. This field specifies the value by which the IPBus clock (ICLK), which is always 1/2 PCLK, is divided in order to generate the external clock output on the EXTCLK pin.</p> <p>0x0 - Divide by 1 0x1 - Divide by 2 0x2 - Divide by 4 0x3 - reserved</p>
MDATA[6]	<p>Endian. This bit specifies the endianness.</p> <p>0x0 - little endian 0x1 - big endian</p>

Table 3 Boot Configuration Encoding (Part 1 of 2)

Signal	Name/Description
MDATA[7]	Boot Device Width. This field specifies the width of the boot device (i.e., Device 0). 0x0 - 8-bit boot device width 0x1 - 16-bit boot device width
MDATA[8]	Reset Mode. This bit specifies the length of time the RSTN signal is driven. 0x0 - Normal reset: RSTN driven for minimum of 4096 clock cycles 0x1 - reserved
MDATA[11:9]	PCI Mode. This bit controls the operating mode of the PCI bus interface. The initial value of the EN bit in the PCIC register is determined by the PCI mode. 0x0 - Disabled (EN initial value is zero) 0x1 - PCI satellite mode with PCI target not ready (EN initial value is one) 0x2 - PCI satellite mode with suspended CPU execution (EN initial value is one) 0x3 - PCI host mode with external arbiter (EN initial value is zero) 0x4 - PCI host mode with internal arbiter using fixed priority arbitration algorithm (EN initial value is zero) 0x5 - PCI host mode with internal arbiter using round robin arbitration algorithm (EN initial value is zero) 0x6 - reserved 0x7 - reserved
MDATA[12]	Disable Watchdog Timer. When this bit is set, the watchdog timer is disabled following a cold reset. 0x0 - Watchdog timer enabled 0x1 - Watchdog timer disabled
MDATA[15:13]	Reserved. These pins must be driven low during boot configuration.

Table 3 Boot Configuration Encoding (Part 2 of 2)

Logic Diagram — RC32438

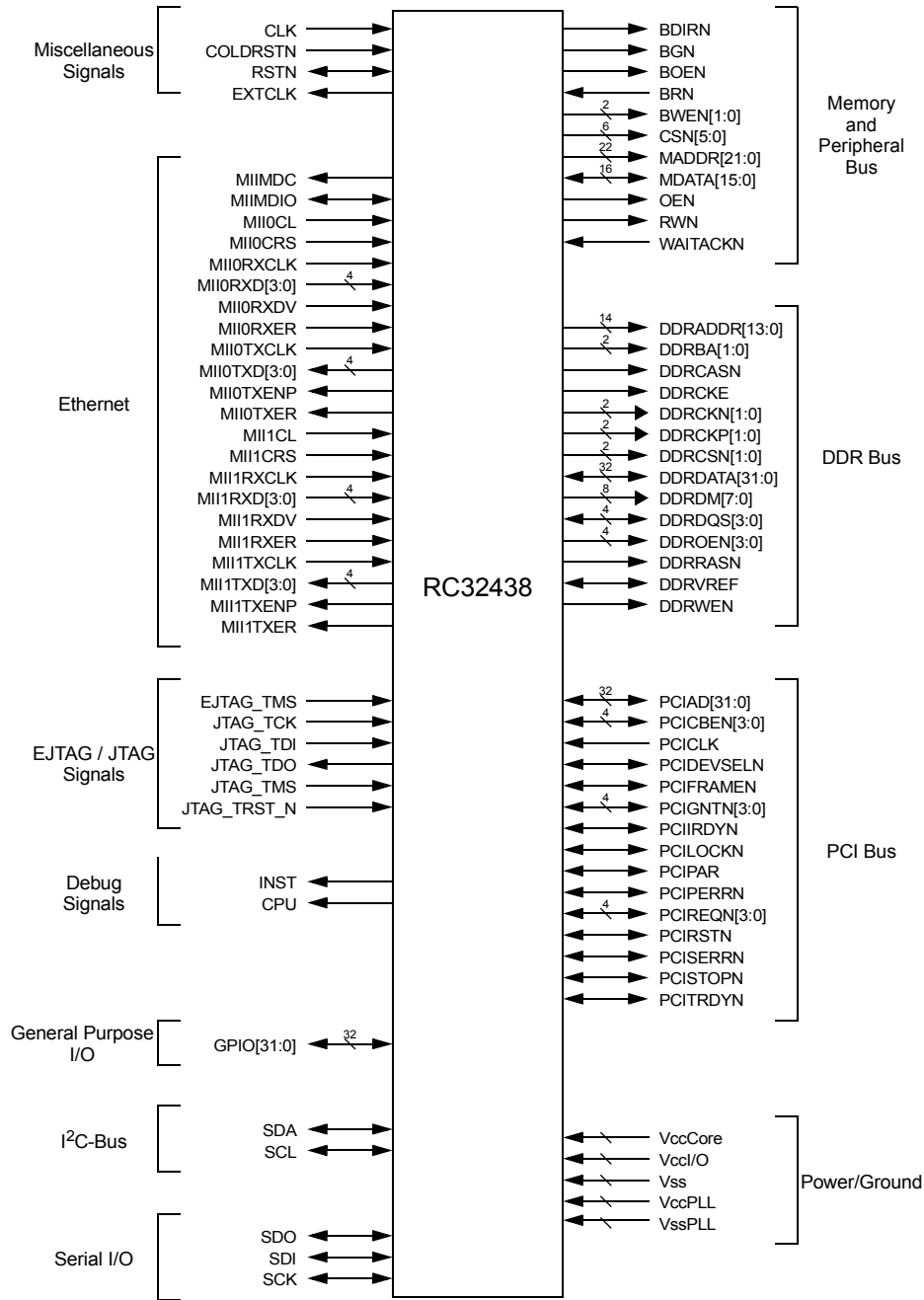

Figure 1 Logic Diagram

AC Timing Definitions

Below are examples of the AC timing characteristics used throughout this document.

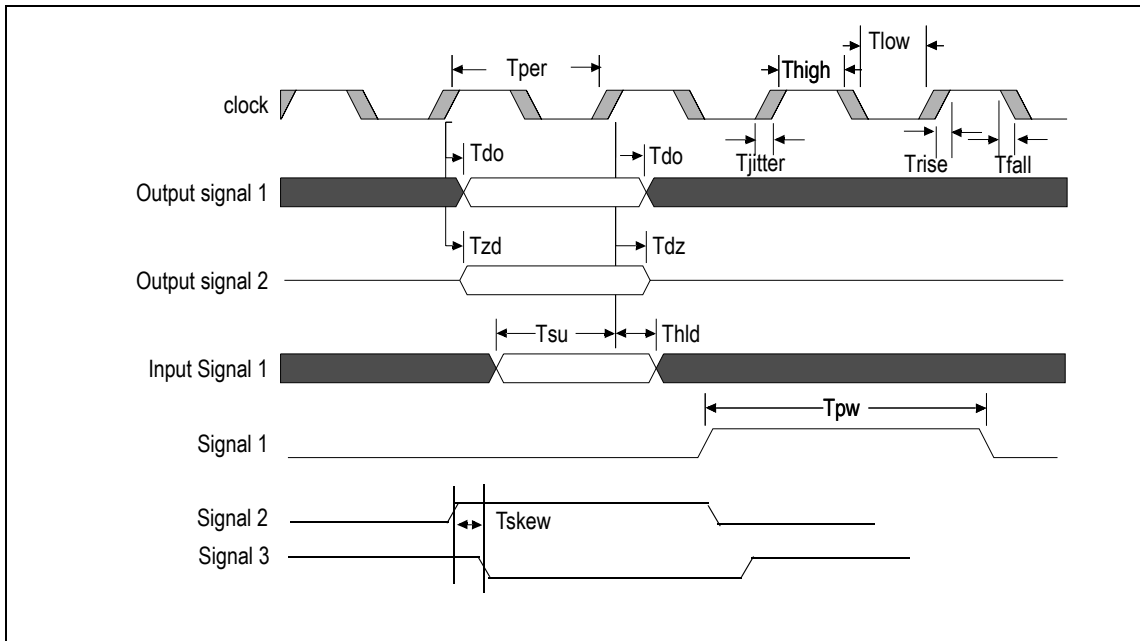

Figure 2 AC Timing Definitions Waveform

Symbol	Definition
Tper	Clock period.
Tlow	Clock low. Amount of time the clock is low in one clock period.
Thigh	Clock high. Amount of time the clock is high in one clock period.
Trise	Rise time. Low to high transition time.
Tfall	Fall time. High to low transition time.
Tjitter	Jitter. Amount of time the reference clock (or signal) edge can vary on either the rising or falling edges.
Tdo	Data out. Amount of time after the reference clock edge that the output will become valid. The minimum time represents the data output hold. The maximum time represents the earliest time the designer can use the data.
Tzd	Z state to data valid. Amount of time after the reference clock edge that the tri-stated output takes to become valid.
Tdz	Data valid to Z state. Amount of time after the reference clock edge that the valid output takes to become tri-stated.
Tsu	Input set-up. Amount of time before the reference clock edge that the input must be valid.
Thld	Input hold. Amount of time after the reference clock edge that the input must remain valid.
Tpw	Pulse width. Amount of time the input or output is active for asynchronous signals.
Tslew	Slew rate. The rise or fall rate for a signal to go from a high to low, or low to high.
X(clock)	Timing value. This notation represents a value of 'X' multiplied by the clock time period of the specified clock. Using 5(CLK) as an example: X = 5 and the oscillator clock (CLK) = 25MHz, then the timing value is 200.
Tskew	Skew. The amount of time two signal edges deviate from one another.

Table 4 AC Timing Definitions

System Clock Parameters

Values based on systems running at recommended supply voltages and operating temperatures, as shown in Tables 15 and 16.

Parameter	Symbol	Reference Edge	200MHz		233MHz		266MHz		300MHz		Units	Timing Diagram Reference
			Min	Max	Min	Max	Min	Max	Min	Max		
PCLK ¹	Frequency	none	200	200	200	233	200	266	200	300	MHz	See Figure 3.
	Tper		5.0	5.0	4.2	5.0	3.8	5.0	3.3	5.0	ns	
ICLK ^{2,3,4}	Frequency	none	100	100	100	116.5	100	133	100	150	MHz	
	Tper		10.0	10.0	10.0	8.5	10.0	7.5	6.7	10.0	ns	
CLK ⁵	Frequency	none	25	66.6	25	77.6	25	88.6	25	100	MHz	
	Tper_5a		15.0	40.0	12.9	40.0	11.2	40.0	10	40	ns	
	Thigh_5a, Tlow_5a		40	60	40	60	40	60	40	60	% of Tper_5a	
	Trise_5a, Tfall_5a		—	3.0	—	3.0	—	3.0	—	3.0	ns	
	Tjitter_5a		—	0.1	—	0.1	—	0.1	—	0.1	ns	

Table 5 Clock Parameters

- The CPU pipeline clock (PCLK) speed is selected during cold reset by the boot configuration vector (see Table 3).
- ICLK is the internal IPBus clock. It is always equal to PCLK divided by 2. This clock cannot be sampled externally.
- The ethernet clock (MIIXRXCLK and MIIXTXCLK) frequency must be equal to or less than 1/2 ICLK (MIIXRXCLK and MIIXTXCLK \leq 1/2(ICLK)).
- PCICLK must be equal to or less than two times ICLK (PCICLK \leq 2(ICLK)) with a maximum PCICLK of 66MHz.
- The input clock (CLK) is input from the external oscillator to the internal PLL.

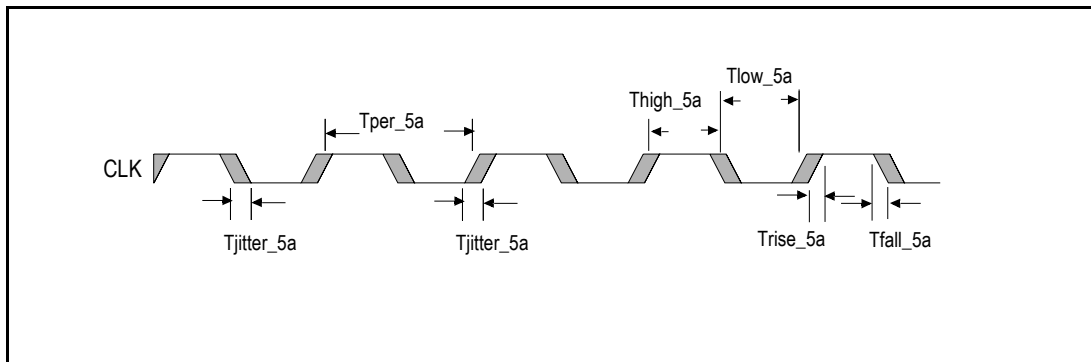

Figure 3 Clock Parameters Waveform

AC Timing Characteristics

Values given below are based on systems running at recommended operating temperatures and supply voltages, shown in Tables 15 and 16.

Signal	Symbol	Reference Edge	200MHz		233MHz		266MHz		300MHz		Unit	Conditions	Timing Diagram Reference
			Min	Max	Min	Max	Min	Max	Min	Max			
Reset													
COLDRSTN ¹	Tpw_6a ²	none	OSC + 0.5	—	OSC + 0.5	—	OSC + 0.5	—	OSC + 0.5	—	ms	Cold reset	See Figures 4 and 5.
	Trise_6a	none	—	5.0	—	5.0	—	5.0	—	5.0	ns	Cold reset	
RSTN ³ (input)	Tpw_6b ²	none	2(CLK)	—	2(CLK)	—	2(CLK)	—	2(CLK)	—	ns	Warm reset	
RSTN ³ (output)	Tdo_6c	COLDRSTN falling	—	15.0	—	15.0	—	15.0	—	15.0	ns	Cold reset	
MDATA[15:0] (boot vector)	Thld_6d	COLDRSTN rising	3.0	—	3.0	—	3.0	—	3.0	—	ns	Cold reset	
	Tdz_6d ²	COLDRSTN falling	—	30.0	—	30.0	—	30.0	—	30.0	ns	Cold reset	
	Tdz_6d ²	RSTN falling	—	5(CLK)	—	5(CLK)	—	5(CLK)	—	5(CLK)	ns	Warm reset	
	Tzd_6d ²	RSTN rising	2(CLK)	—	2(CLK)	—	2(CLK)	—	2(CLK)	—	ns	Warm reset	

Table 6 Reset and System AC Timing Characteristics

¹. The COLDRSTN minimum pulse width is the oscillator stabilization time (OSC) plus 0.5 ms with V_{cc} stable.

². The values for this symbol were determined by calculation, not by testing.

³. RSTN is a bidirectional signal. It is treated as an asynchronous input.

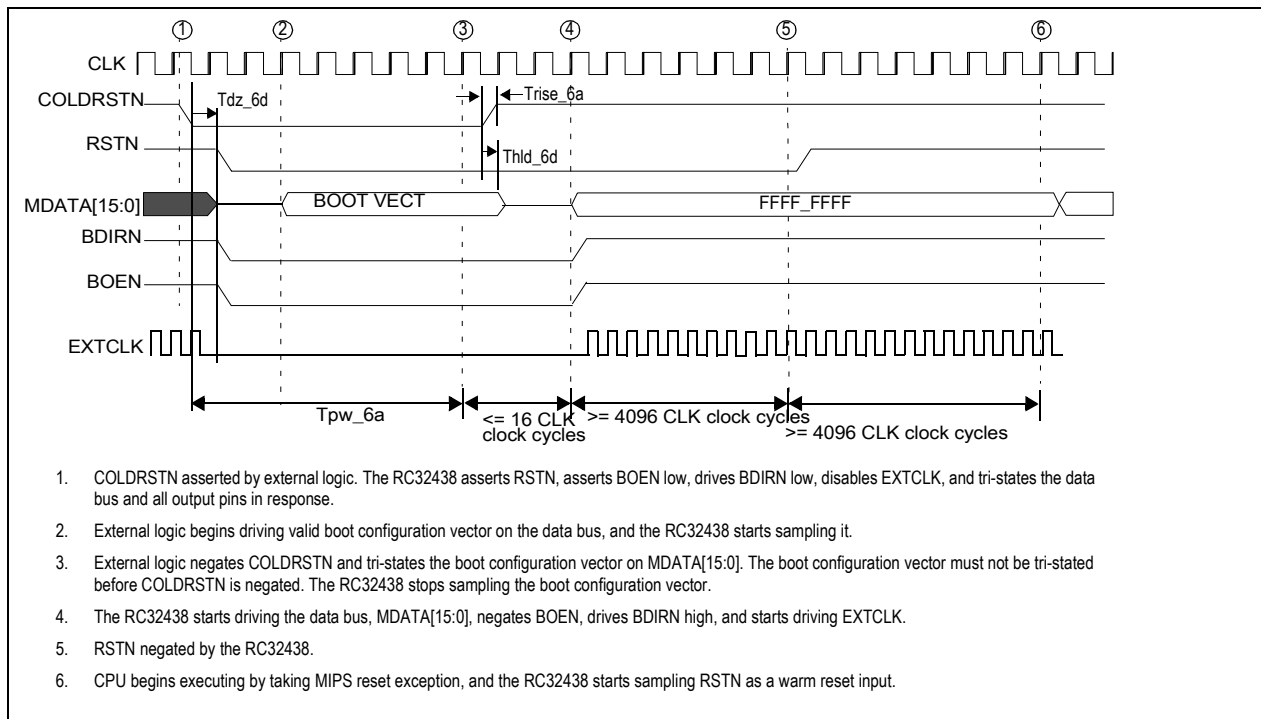

Figure 4 Cold Reset AC Timing Waveform

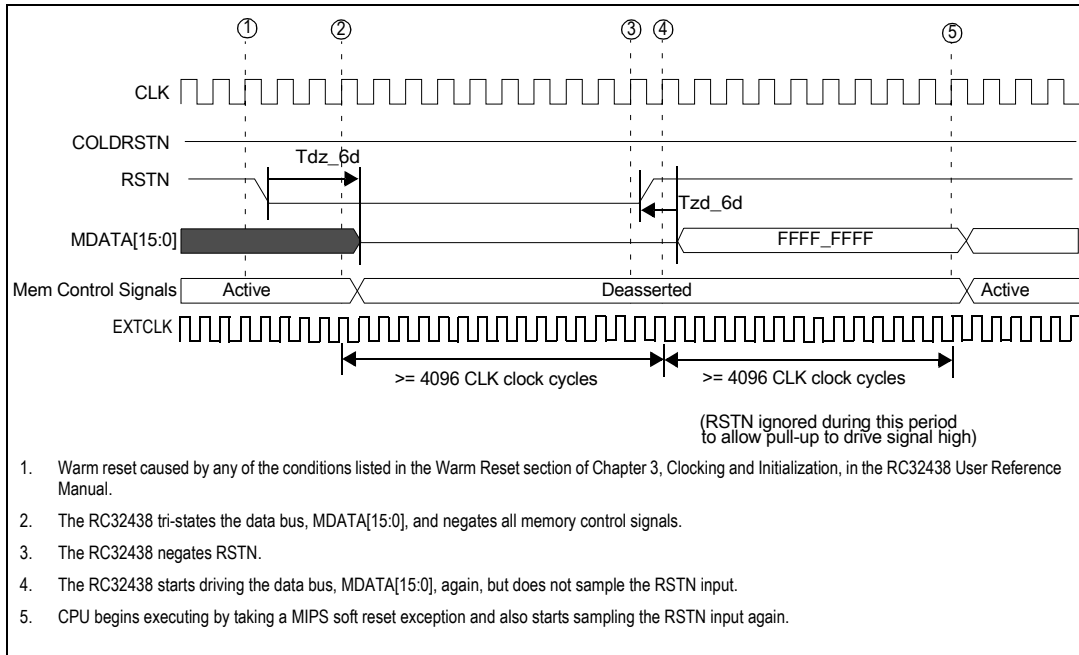

Figure 5 Warm Reset AC Timing Waveform

Signal	Symbol ¹	Reference Edge	200MHz		233MHz		266MHz		300MHz		Unit	Conditions	Timing Diagram Reference
			Min	Max	Min	Max	Min	Max	Min	Max			
Memory Bus - DDR Access													
DDRDQA[31:0]	Tskew_7g ²	DDRQSDx	0.0	0.9	0.0	0.9	0.0	0.9	0.0	0.8	ns		See Figures 6 and 7.
	Tdo_7k ³		1.5	3.3	1.1	2.9	0.9	2.7	0.7	2.4	ns		
DDRDM[7:0]	Tdo_7l	DDRQSDx	1.5	3.3	1.1	2.9	0.9	2.7	0.7	2.4	ns		
DDRQSD[3:0]	Tac	DDRCKPx	-0.75	0.75	-0.75	0.75	-0.75	0.75	-0.75	0.75	ns		
DDRADDR[13:0], DDRBA[1:0], DDRCASN, DDRCKE, DDRCNS[1:0], DDROEN[3:0], DDRRASN, DDRWEN	Tdo_7m ⁴	DDRCKPx	1.1	4.5	1.1	4.5	1.1	4.5	1.1	4.5	ns		

Table 7 DDR SDRAM Timing Characteristics

¹ In the DDR data sheet: Tskew_7g = t_{DQSQ}; Tdo_7k = t_{DH}, t_{DS}; Tdo_7l = t_{DH}, t_{DS}; Tac = t_{AC}; Tdo_7m = t_{IH}, t_{IS}.

² Meets DDR timing requirements for DDR 266 SDRAMs with 400 ps remaining margin to compensate for PCB propagation mismatches, which is adequate to guarantee functional timing, provided the RC32438 DDR layout guidelines are followed.

³ Setup times are calculated as applicable clock period - Tdo max. For example, if the DDR is running at 266MHz, it uses a 133MHz input clock. The period for a 133MHz clock is 7.5ns. If the Tdo max value is 4.5ns, the T_{IS} parameter is 7.5ns minus 4.5ns = 3ns. The DDR spec for this parameter is 1ns, so there is 2ns of slack left over for board propagation. Calculations for T_{DS} are similar, but since this parameter is taken relative to the DDRQSD signals, which are referenced on both edges, the effective period with a 133MHz input clock is only 3.75ns. So, if the max Tdo is 2.7ns, we have 3.75ns minus 2.7ns = 1.05ns for T_{DS}. The DDR data sheet specs a value of 0.5ns for 266MHz, so this leaves 0.55ns slack for board propagation delays.

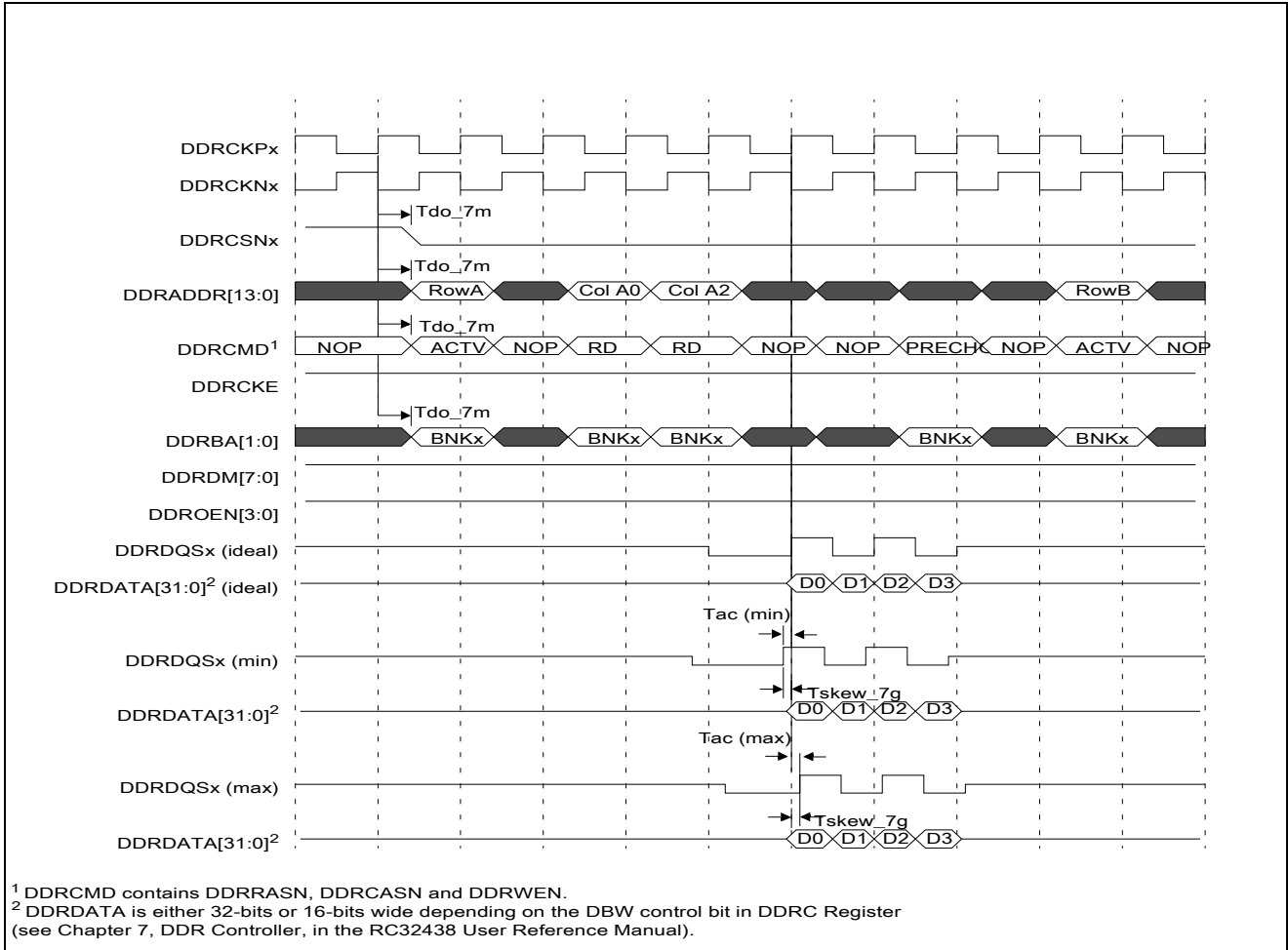

Figure 6 DDR SDRAM AC Timing Waveform - SDRAM Read Access

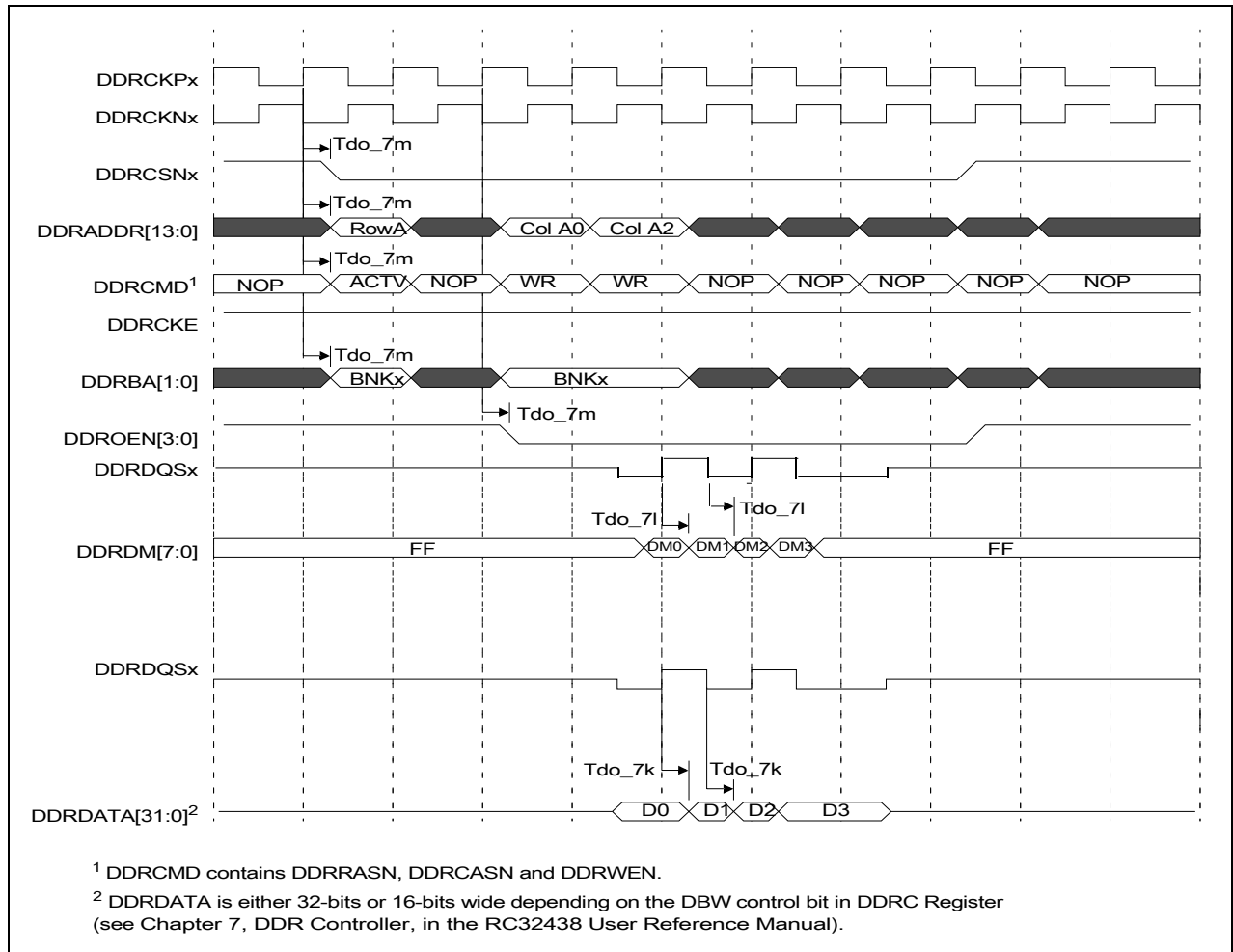

Figure 7 DDR SDRAM Timing Waveform — Write Access

Signal	Symbol	Reference Edge	200MHz		233MHz		266MHz		300MHz		Unit	Conditions	Timing Diagram Reference
			Min	Max	Min	Max	Min	Max	Min	Max			
Memory and Peripheral Bus ¹													See Figures 8 and 9.
MADDR[21:0]	Tdo_8a	EXTCLK rising	0.0	5.0	0.0	5.0	0.0	5.0	0.0	5.0	ns		
	Tdz_8a ²		0.0	0.1	0.0	0.1	0.0	0.1	0.0	0.1	ns		
	Tzd_8a ²		0.5	2.3	0.5	2.3	0.5	2.3	0.5	2.3	ns		
MADDR[25:22]	Tdo_8b	EXTCLK rising	0.0	6.5	0.0	6.5	0.0	6.5	0.0	6.5	ns		
	Tdz_8b ²		0.7	1.5	0.7	1.5	0.7	1.5	0.7	1.5	ns		
	Tzd_8b ²		1.2	3.3	1.2	3.3	1.2	3.3	1.2	3.3	ns		

Table 8 Memory and Peripheral Bus AC Timing Characteristics (Part 1 of 3)

Signal	Symbol	Reference Edge	200MHz		233MHz		266MHz		300MHz		Unit	Conditions	Timing Diagram Reference
			Min	Max	Min	Max	Min	Max	Min	Max			
MDATA[15:0]	Tsu_8c	EXTCLK rising	7.0	—	7.0	—	7.0	—	7.0	—	ns		See Figures 8 and 9 (cont.)
	Thld_8c		0.0	—	0.0	—	0.0	—	0.0	—	ns		
	Tdo_8c		0.0	4.0	0.0	4.0	0.0	4.0	0.0	4.0	ns		
	Tdz_8c ²		0.0	0.1	0.0	0.1	0.0	0.1	0.0	0.1	ns		
	Tzd_8c ²		0.5	2.2	0.5	2.2	0.5	2.2	0.5	2.2	ns		
EXTCLK ³	Tper_8d	none	10.0	—	8.33	—	7.5	—	6.66	—	ns		
BDIRN	Tdo_8e	EXTCLK rising	1.0	4.0	1.0	4.0	1.0	4.0	1.0	4.0	ns		
	Tdz_8e ²		-1.0	-0.1	-1.0	-0.1	-1.0	-0.1	-1.0	-0.1	ns		
	Tzd_8e ²		0.4	1.0	0.4	1.0	0.4	1.0	0.4	1.0	ns		
BOEN	Tdo_8f	EXTCLK rising	1.0	4.0	1.0	4.0	1.0	4.0	1.0	4.0	ns		
	Tdz_8f ²		0.1	0.4	0.1	0.4	0.1	0.4	0.1	0.4	ns		
	Tzd_8f ²		1.1	2.0	1.1	2.0	1.1	2.0	1.1	2.0	ns		
BRN	Tsu_8g	EXTCLK rising	5.5	—	5.5	—	5.5	—	5.5	—	ns		
	Thld_8g		0.0	—	0.0	—	0.0	—	0.0	—	ns		
BGN	Tdo_8h	EXTCLK rising	1.0	4.0	1.0	4.0	1.0	4.0	1.0	4.0	ns		
WAITACKN ⁴	Tsu_8h	EXTCLK rising	5.8	—	5.8	—	5.8	—	5.8	—	ns		
	Thld_8h		0.0	—	0.0	—	0.0	—	0.0	—	ns		
	Tpw_8h ²	none	2(EXT-CLK)	—	2(EXT-CLK)	—	2(EXT-CLK)	—	2(EXT-CLK)	—	ns		
CSN[5:0]	Tdo_8i	EXTCLK rising	0.0	4.0	0.0	4.0	0.0	4.0	0.0	4.0	ns		
	Tdz_8i ²		0.1	0.4	0.1	0.4	0.1	0.4	0.1	0.4	ns		
	Tzd_8i ²		0.6	2.2	0.6	2.2	0.6	2.2	0.6	2.2	ns		
RWN	Tdo_8j	EXTCLK rising	0.0	4.0	0.0	4.0	0.0	4.0	0.0	4.0	ns		
	Tdz_8j ²		-0.7	0.1	-0.7	0.1	-0.7	0.1	-0.7	0.1	ns		
	Tzd_8j ²		0.6	1.1	0.6	1.1	0.6	1.1	0.6	1.1	ns		
OEN	Tdo_8k	EXTCLK rising	0.0	4.0	0.0	4.0	0.0	4.0	0.0	4.0	ns		
	Tdz_8k ²		-0.4	0.2	-0.4	0.2	-0.4	0.2	-0.4	0.2	ns		
	Tzd_8k ²		0.8	1.5	0.8	1.5	0.8	1.5	0.8	1.5	ns		
BWEN[1:0]	Tdo_8l	EXTCLK rising	0.0	4.0	0.0	4.0	0.0	4.0	0.0	4.0	ns		
	Tdz_8l ²		0	0.2	0	0.2	0	0.2	0	0.2	ns		
	Tzd_8l ²		0.8	1.7	0.8	1.7	0.8	1.7	0.8	1.7	ns		

Table 8 Memory and Peripheral Bus AC Timing Characteristics (Part 2 of 3)

Signal	Symbol	Reference Edge	200MHz		233MHz		266MHz		300MHz		Unit	Conditions	Timing Diagram Reference
			Min	Max	Min	Max	Min	Max	Min	Max			
DMAREQN[1:0]	Tpw_8n ²	None	2(ICLK)	—	2(ICLK)	—	2(ICLK)	—	2(ICLK)	—	ns		See Figures 10 and 11.
DMADONEN[1:0]	Tsu_8o	EXTCLK rising	6.0	—	6.0	—	6.0	—	6.0	—	ns		
	Thld_8o		1.0	—	1.0	—	1.0	—	1.0	—	ns		
DMAFINN[1:0]	Tdo_8p	EXTCLK rising	1.5	6.0	1.5	6.0	1.5	6.0	1.5	6.0	ns		
CPU, INST	Tdo_8m	EXTCLK rising	2.0	10.0	2.0	10.0	2.0	10.0	2.0	10.0	ns		See Figures 8 and 9.

Table 8 Memory and Peripheral Bus AC Timing Characteristics (Part 3 of 3)

- ¹ The RC32438 provides bus turnaround cycles to prevent bus contention when going from a read to write, write to read, and during external bus ownership. For example, there are no cycles where an external device and the RC32438 are both driving. See Chapter 6, Device Controller, in the RC32438 User Reference Manual.
- ² The values for this symbol were determined by calculation, not by testing.
- ³ The frequency of EXTCLK is programmable. See the External Clock Divider description in Table 3 of this data sheet.
- ⁴ WAITACKN must meet the setup and hold times if it is synchronous or the minimum pulse width if it is asynchronous.

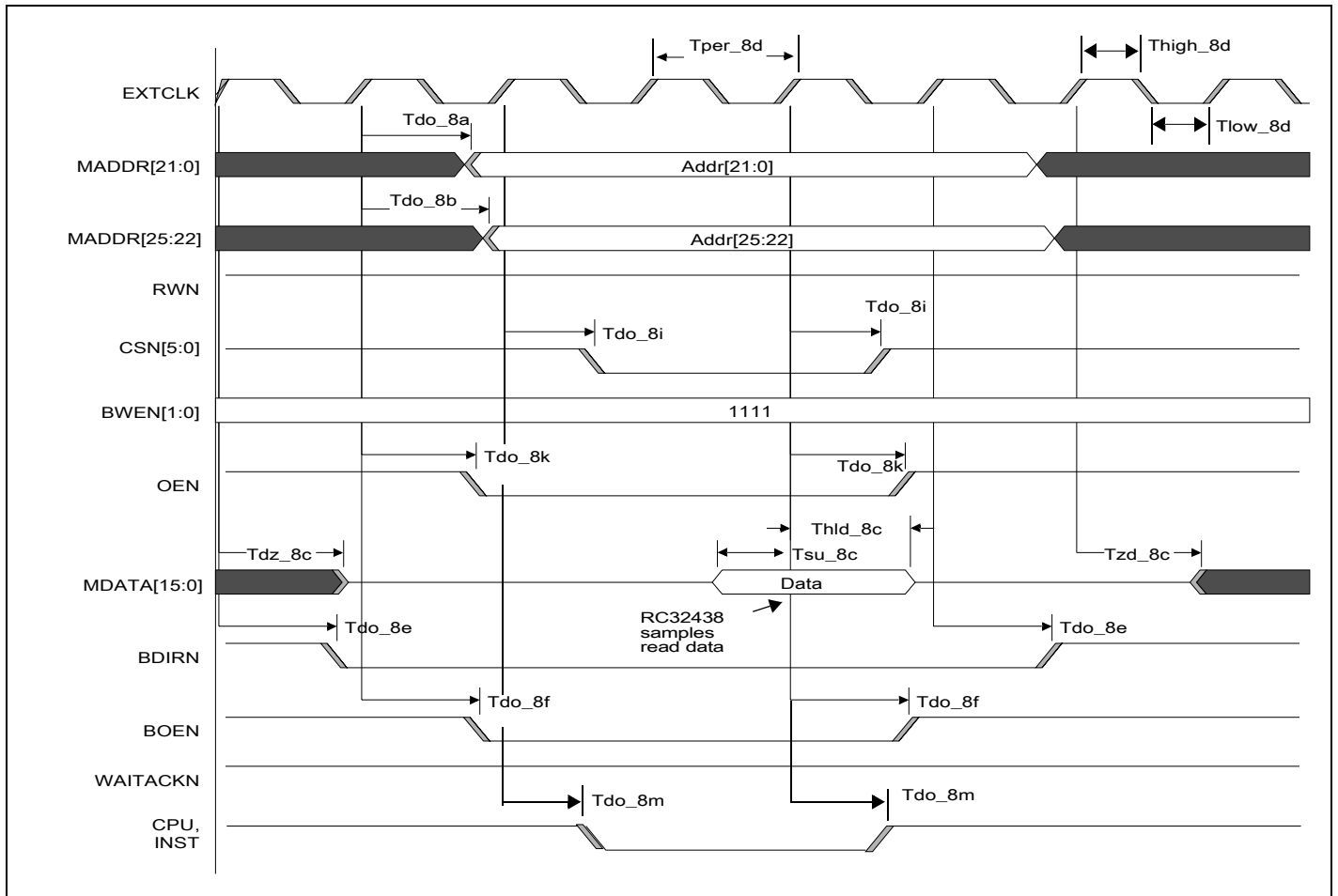

Figure 8 Memory and Peripheral Bus AC Timing Waveform — Read Access

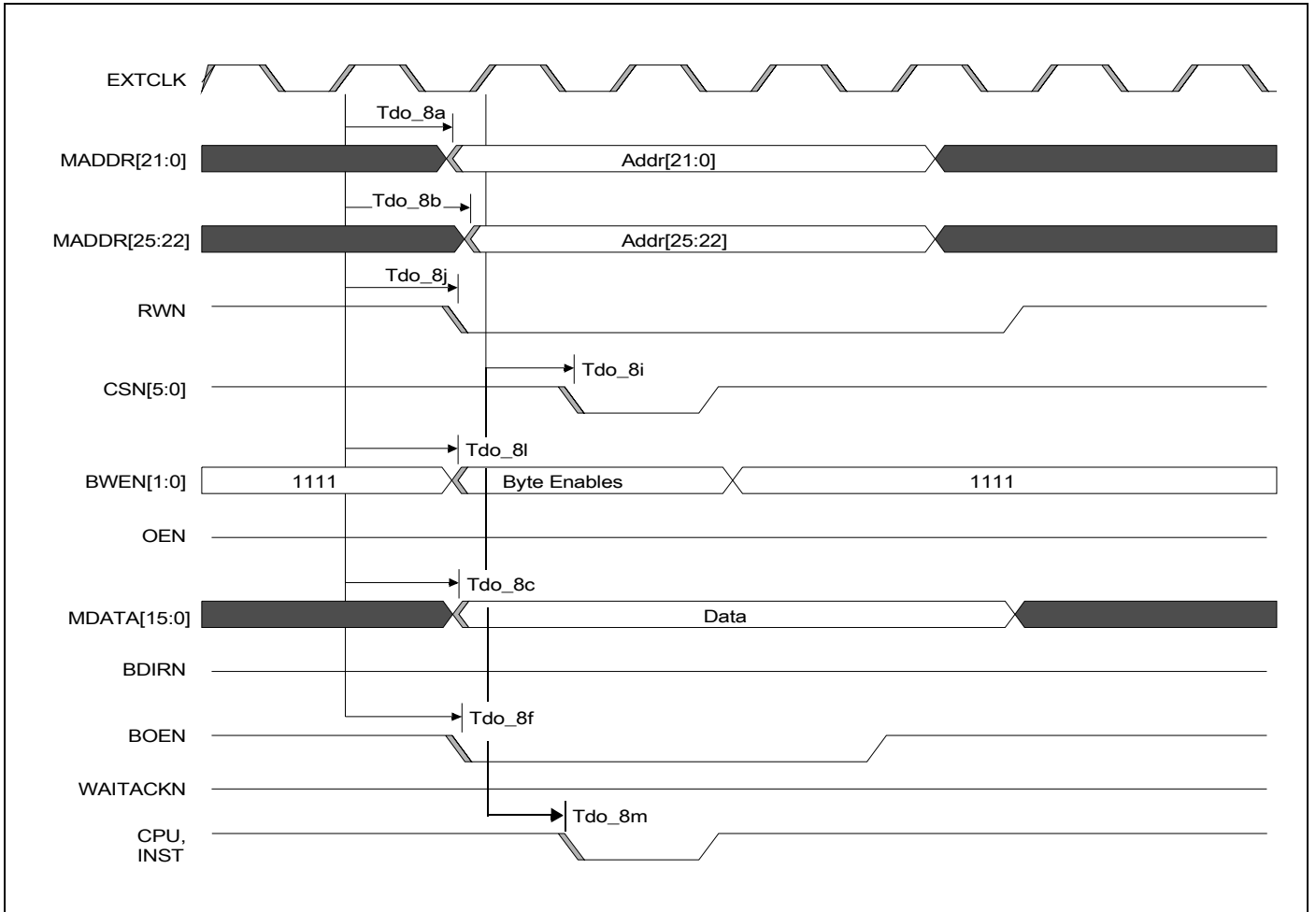

Figure 9 Memory and Peripheral Bus AC Timing Waveform — Write Access

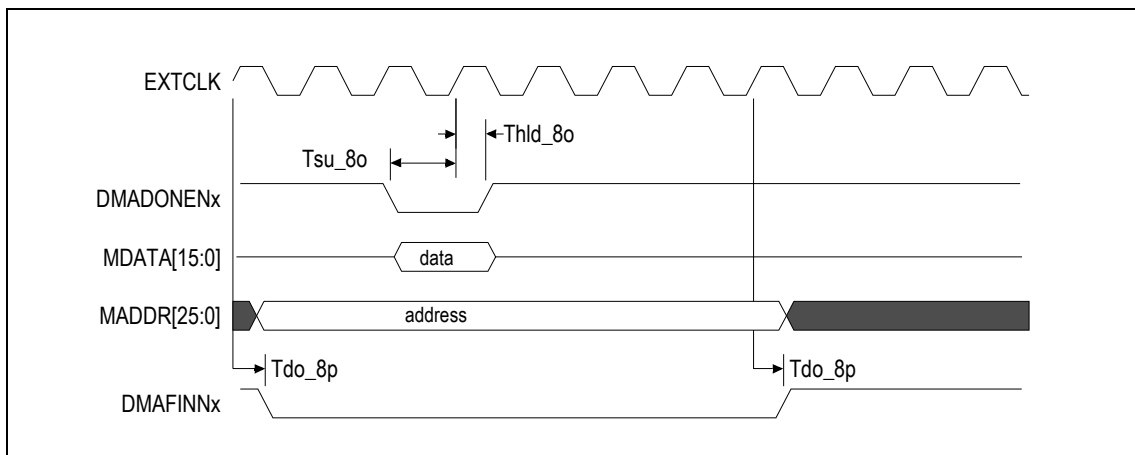

Figure 10 DMADONEN and DMAFINN AC Timing Waveform

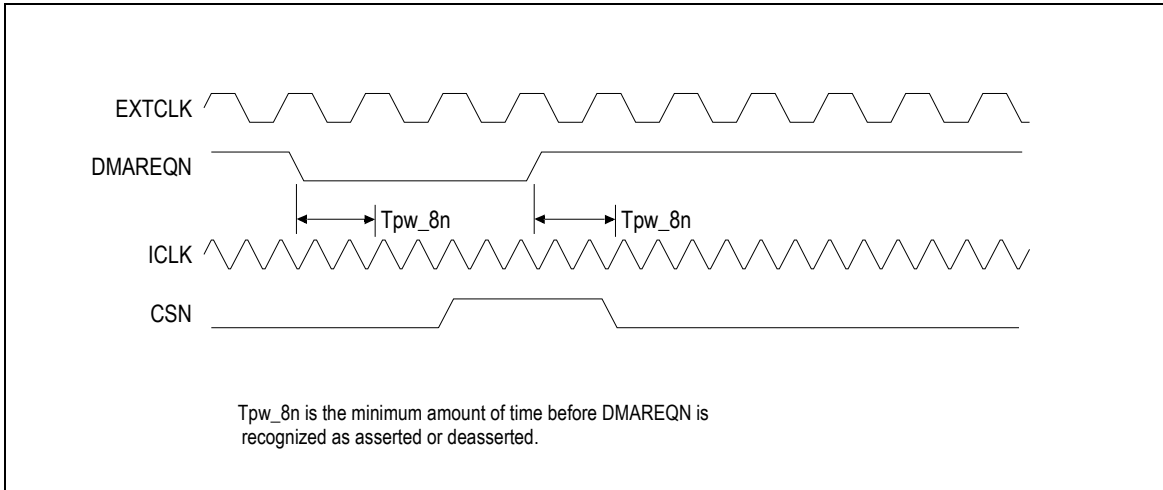

Figure 11 DMAREQN AC Timing Waveform

Signal	Symbol	Reference Edge	200MHz		233MHz		266MHz		300MHz		Unit	Conditions	Timing Diagram Reference
			Min	Max	Min	Max	Min	Max	Min	Max			
Ethernet ¹													
MIIMDC	Tper_9a	None	40.0	—	33.3	—	30.0	—	30.0	—	ns		See Figure 12.
	Thigh_9a, Tlow_9a		16.0	—	13.0	—	12.0	—	12.0	—	ns		
MIIMDIO	Tsu_9b	MIIMDC rising	10.0	—	10.0	—	10.0	—	10.0	—	ns		
	Thld_9b		0.0	—	0.0	—	0.0	—	0.0	—	ns		
	Tdo_9b ²		10	300	10	300	10	300	10	300	ns		
MIIXCLK, MIIXCLK ³	Tper_9c	None	399.96	400.4	399.96	400.4	399.96	400.4	399.96	400.4	ns	10 Mbps	
	Thigh_9c, Tlow_9c		140	260	140	260	140	260	140	260	ns		
	Trise_9c, Tfall_9c		—	3.0	—	3.0	—	3.0	—	3.0	ns		
MIIXCLK, MIIXCLK ³	Tper_9d	None	39.9	40.0	39.9	40.0	39.9	40.0	39.9	40.0	ns	100 Mbps	
	Thigh_9d, Tlow_9d		14.0	26.0	14.0	26.0	14.0	26.0	14.0	26.0	ns		
	Trise_9d, Tfall_9d		—	2.0	—	2.0	—	2.0	—	2.0	ns		
MIIXD[3:0], MIIXDV, MIIXER	Tsu_9e	MIIXCLK rising	10.0	—	10.0	—	10.0	—	10.0	—	ns		
	Thld_9e		10.0	—	10.0	—	10.0	—	10.0	—	ns		
MIIXD[3:0], MIIXENP, MIIXER	Tdo_9f	MIIXCLK rising	0.0	25.0	0.0	25.0	0.0	25.0	0.0	25.0	ns		

Table 9 Ethernet AC Timing Characteristics

¹ There are two MII interfaces and the timing is the same for each. "X" represents interface 0 or 1.

² The values for this symbol were determined by calculation, not by testing.

³ The ethernet clock (MIIXRXCLK and MIIXTXCLK) frequency must be equal to or less than 1/2 ICLK (MIIXRXCLK and MIIXTXCLK <= 1/2(ICLK)).

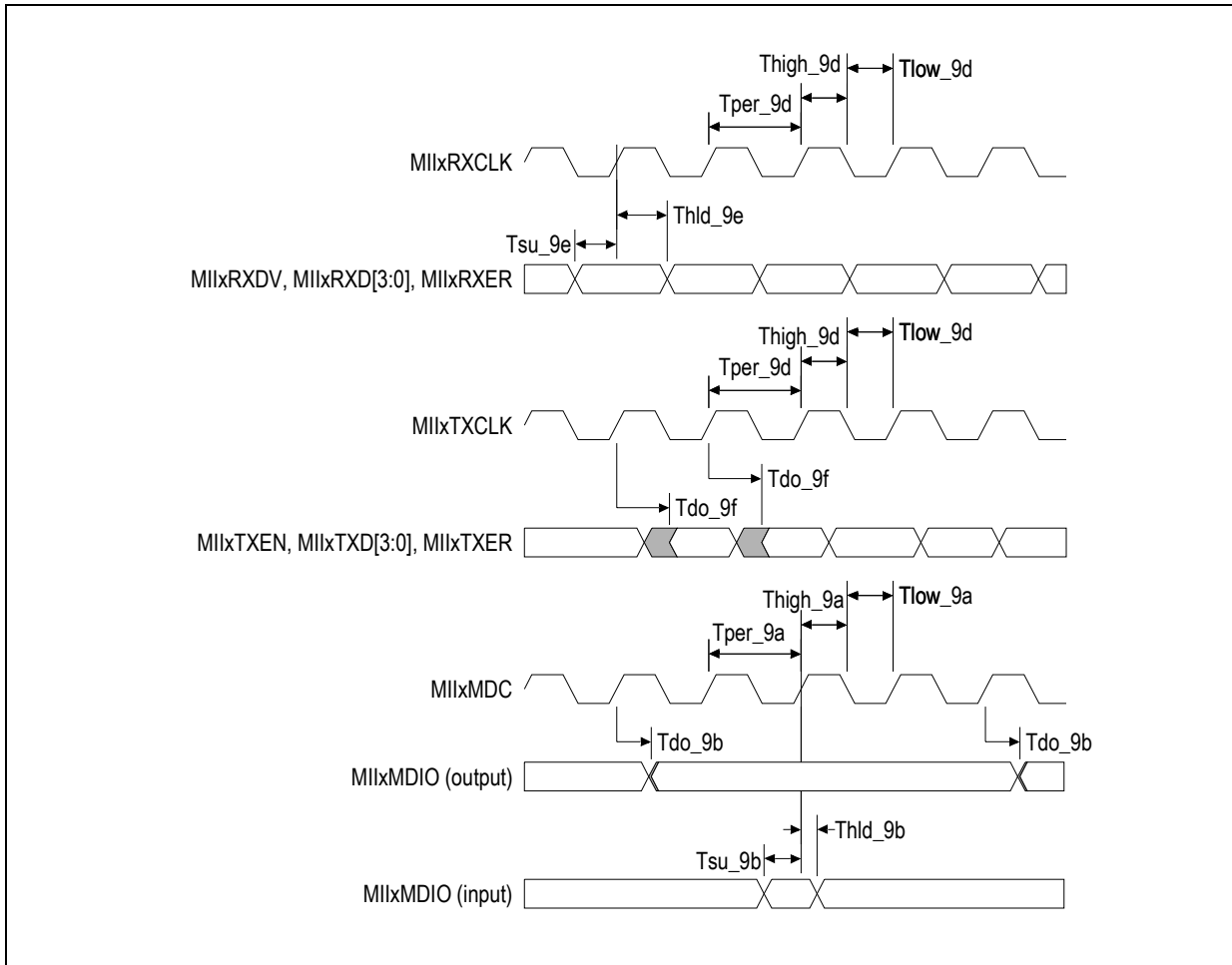

Figure 12 Ethernet AC Timing Waveform

Signal	Symbol	Reference Edge	200MHz		233MHz		266MHz		300MHz		Unit	Conditions	Timing Diagram Reference
			Min	Max	Min	Max	Min	Max	Min	Max			
PCI ¹													
PCICLK ²	Tper_10a	none	15.0	30.0	15.0	30.0	15.0	30.0	15.0	30.0	ns	66 MHz PCI	See Figure 13.
	Thigh_10a, Tlow_10a		6.0	—	6.0	—	6.0	—	6.0	—	ns		
	Tslew_10a		1.5	4.0	1.5	4.0	1.5	4.0	1.5	4.0	V/ns		
PCIA[31:0], PCIBEN[3:0], PCIDEVSELN, PCIFRAMEN, PCIIRDYN, PCILOCKN, PCIPAR, PCIPERRN, PCIS-TOPN, PCITRDY	Tsu_10b	PCICLK rising	3.0	—	3.0	—	3.0	—	3.0	—	ns		See Figure 13 (cont.)
	Thld_10b		0	—	0	—	0	—	0	—	ns		
	Tdo_10b		2.0	6.0	2.0	6.0	2.0	6.0	2.0	6.0	ns		
	Tdz_10b ³		—	14.0	—	14.0	—	14.0	—	14.0	ns		
PCIGNTN[3:0], PCIREQN[3:0]	Tsu_10c	PCICLK rising	5.0	—	5.0	—	5.0	—	5.0	—	ns		
	Thld_10c		0	—	0	—	0	—	0	—	ns		
	Tdo_10c		2.0	6.0	2.0	6.0	2.0	6.0	2.0	6.0	ns		
PCIRSTN (output) ⁴	Tpw_10d ³	None	4000 (CLK)	—	4000 (CLK)	—	4000 (CLK)	—	4000 (CLK)	—	ns	See Figures 15 and 16	
PCIRSTN (input) ^{4,5}	Tpw_10e ³	None	2(CLK)	—	2(CLK)	—	2(CLK)	—	2(CLK)	—	ns		
	Tdz_10e ³	PCIRSTN falling	6(CLK)	—	6(CLK)	—	6(CLK)	—	6(CLK)	—	ns		
PCISERRN ⁶	Tsu_10f	PCICLK rising	3.0	—	3.0	—	3.0	—	3.0	—	ns	See Figure 13	
	Thld_10f		0	—	0	—	0	—	0	—	ns		
	Tdo_10f		2.0	6.0	2.0	6.0	2.0	6.0	2.0	6.0	ns		
PCIMUINTN ⁶	Tdo_10g	PCICLK rising	4.7	11.1	4.7	11.1	4.7	11.1	4.7	11.1	ns		

Table 10 PCI AC Timing Characteristics

¹ This PCI interface conforms to the PCI Local Bus Specification, Rev 2.2.

² PCICLK must be equal to or less than two times ICLK ($PCICLK \leq 2(ICLK)$) with a maximum PCICLK of 66MHz.

³ The values for this symbol were determined by calculation, not by testing.

⁴ PCIRSTN is an output in host mode and an input in satellite mode.

⁵ To meet the PCI delay specification from reset asserted to outputs floating, the PCI reset should be logically combined with the COLDRSTN input, instead of input on PCIRSTN.

⁶ PCISERRN and PCIMUINTN use open collector I/O types.

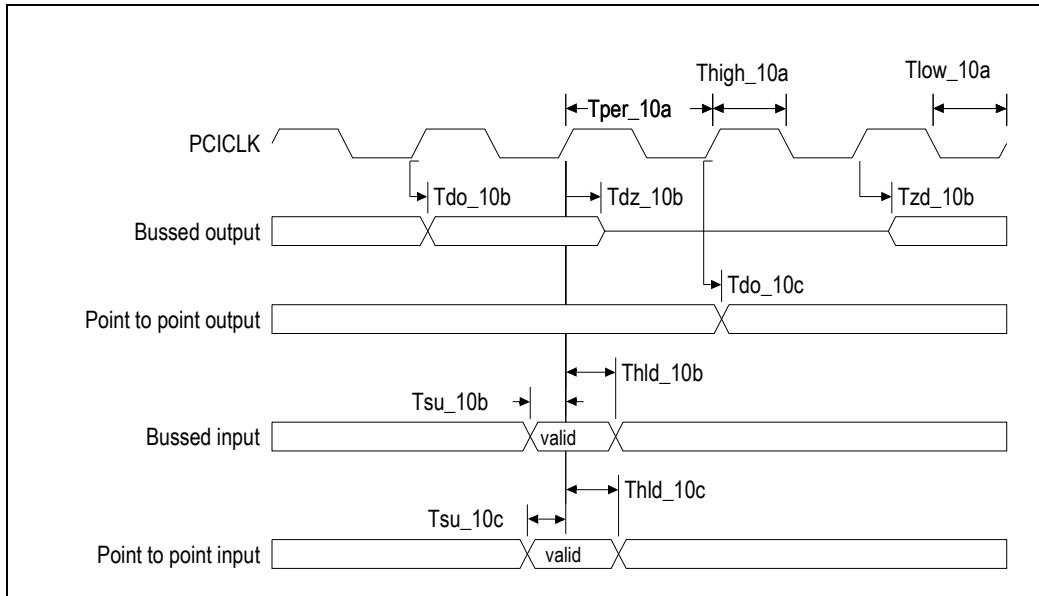

Figure 13 PCI AC Timing Waveform

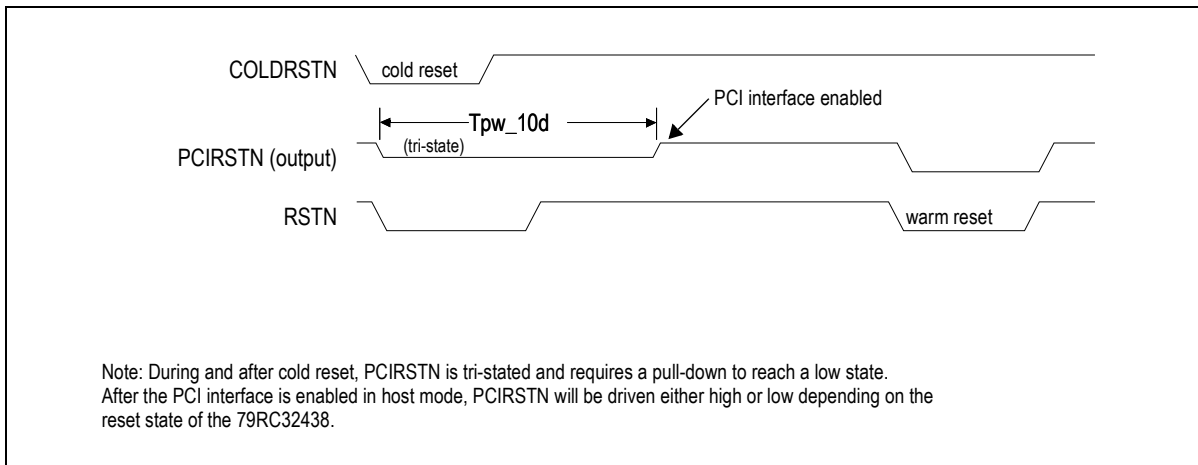

Figure 14 PCI AC Timing Waveform — PCI Reset in Host Mode

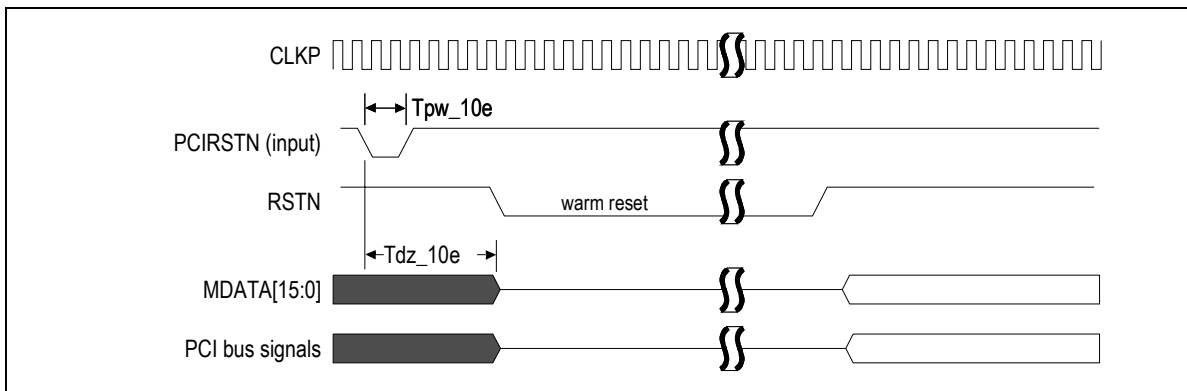

Figure 15 PCI AC Timing Waveform — PCI Reset in Satellite Mode

Signal	Symbol	Reference Edge	200MHz		233MHz		266MHz		300MHz		Unit	Conditions	Timing Diagram Reference
			Min	Max	Min	Max	Min	Max	Min	Max			
I²C¹													
SCL	Frequency	none	0	100	0	100	0	100	0	100	kHz	100 KHz	See Figure 16.
	Thigh_12a, Tlow_12a		4.0	—	4.0	—	4.0	—	4.0	—	μs		
	Trise_12a		—	1000	—	1000	—	1000	—	1000	ns		
	Tfall_12a		—	300	—	300	—	300	—	300	ns		
SDA	Tsu_12b	SCL rising	250	—	250	—	250	—	250	—	ns		
	Thld_12b		0	3.45	0	3.45	0	3.45	0	3.45	μs		
	Trise_12b		—	1000	—	1000	—	1000	—	1000	ns		
	Tfall_12b		—	300	—	300	—	300	—	300	ns		
Start or repeated start condition	Tsu_12c	SDA falling	4.7	—	4.7	—	4.7	—	4.7	—	μs		
	Thld_12c		4.0	—	4.0	—	4.0	—	4.0	—	μs		
Stop condition	Tsu_12d	SDA rising	4.0	—	4.0	—	4.0	—	4.0	—	μs		
Bus free time between a stop and start condition	Tdelay_12e		4.7	—	4.7	—	4.7	—	4.7	—	μs		
SCL	Frequency	none	0	400	0	400	0	400	0	400	kHz	400 KHz	
	Thigh_12a, Tlow_12a		0.6	—	0.6	—	0.6	—	0.6	—	μs		
	Trise_12a		—	300	—	300	—	300	—	300	ns		
	Tfall_12a		—	300	—	300	—	300	—	300	ns		
SDA	Tsu_12b	SCL rising	100	—	100	—	100	—	100	—	ns		
	Thld_12b		0	0.9	0	0.9	0	0.9	0	0.9	μs		
	Trise_12b		—	300	—	300	—	300	—	300	ns		
	Tfall_12ba		—	300	—	300	—	300	—	300	ns		
Start or repeated start condition	Tsu_12c	SDA falling	0.6	—	0.6	—	0.6	—	0.6	—	μs		
	Thld_12c		0.6	—	0.6	—	0.6	—	0.6	—	μs		
Stop condition	Tsu_12d	SDA rising	0.6	—	0.6	—	0.6	—	0.6	—	μs		
Bus free time between a stop and start condition	Tdelay_12e		1.3	—	1.3	—	1.3	—	1.3	—	μs		

Table 11 I²C AC Timing Characteristics

¹: For more information, see the I²C-Bus specification by Philips Semiconductor.

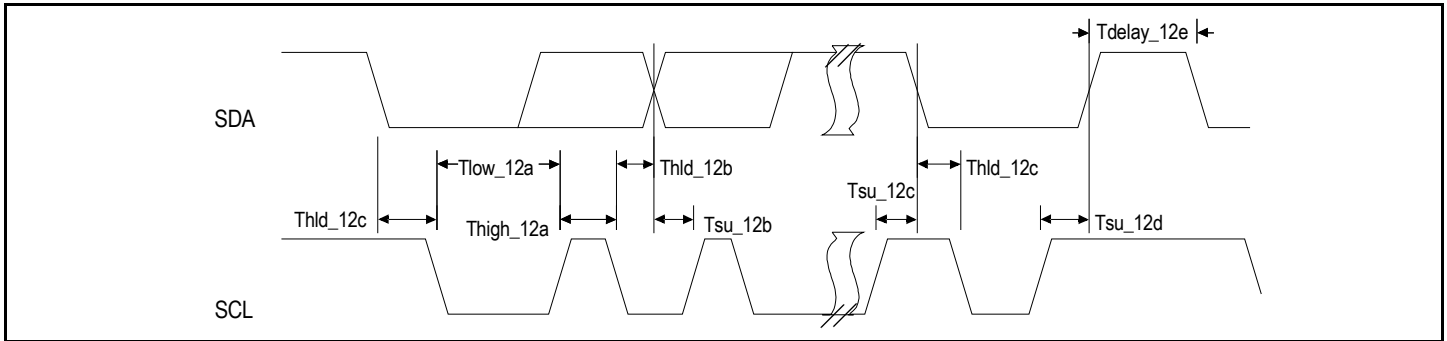

Figure 16 I²C AC Timing Waveform

Signal	Symbol	Reference Edge	200MHz		233MHz		266MHz		300MHz		Unit	Conditions	Timing Diagram Reference
			Min	Max	Min	Max	Min	Max	Min	Max			
GPIO													
GPIO[31:0] ¹	Tpw_13b ²	None	2(ICLK)	—	2(ICLK)	—	2(ICLK)	—	2(ICLK)	—	ns		See Figure 17.

Table 12 GPIO AC Timing Characteristics

¹. GPIO signals must meet the setup and hold times if they are synchronous or the minimum pulse width if they are asynchronous.

². The values for this symbol were determined by calculation, not by testing.

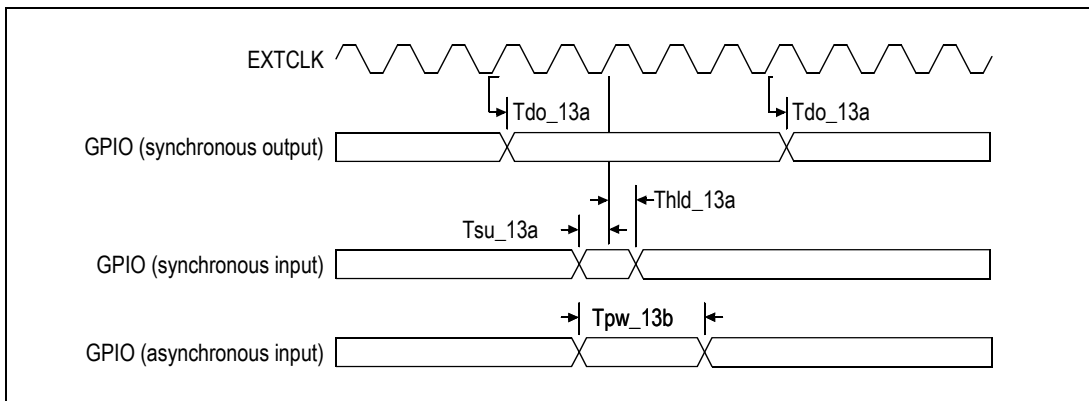

Figure 17 GPIO AC Timing Waveform

Signal	Symbol	Reference Edge	200MHz		233MHz		266MHz		300MHz		Unit	Conditions	Timing Diagram Reference
			Min	Max	Min	Max	Min	Max	Min	Max			
SPI¹													
SCK	Tper_15a	None	—	1920	—	1920	—	1920	—	1920	ns	33 MHz PCI	See Figures 18, 19, 20 and 21.
	Tper_15a		—	960	—	960	—	960	—	960	ns	66 MHz PCI	
	Tper_15a		100	166667	100	166667	100	166667	100	166667	ns	SPI	
	Thigh_15a, Tlow_15a		930	990	930	990	930	990	930	990	ns	33 MHz PCI	
	Thigh_15a, Tlow_15a		465	495	465	495	465	495	465	495	ns	66 MHz PCI	
	Thigh_15a, Tlow_15a		40	83353	40	83353	40	83353	40	83353	ns	SPI	
SDI	Tsu_15b	SCK rising or falling	60	—	60	—	60	—	60	—	ns	SPI or PCI	
	Thld_15b		60	—	60	—	60	—	60	—	ns		
SDO	Tdo_15c	SCK rising or falling	0	60	0	60	0	60	0	60	ns	SPI or PCI	
PCIEECS ²	Tdo_15d	SCK rising or falling	0	60	0	60	0	60	0	60	ns	PCI	
SCK, SDI, SDO ³	Tpw_15e	None	2(ICLK)	—	2(ICLK)	—	2(ICLK)	—	2(ICLK)	—	ns	Bit I/O	

Table 13 SPI AC Timing Characteristics

- ¹ In SPI mode, the SCK period and sampling edge are programmable. In PCI mode, the SCK period is fixed and the sampling edge is rising.
- ² PCIEECS is the PCI serial EEPROM chip select. It is an alternate function of PCIGNTN[1].
- ³ In Bit I/O mode, SCK, SDI, and SDO must meet the setup and hold times if they are synchronous or the minimum pulse width if they are asynchronous.

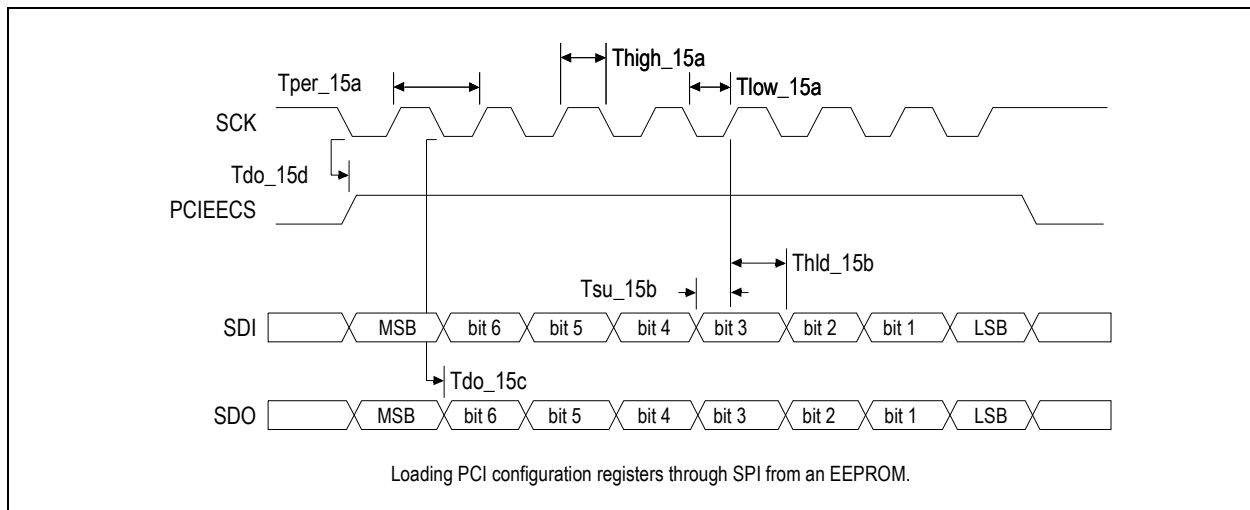

Figure 18 SPI AC Timing Waveform — PCI Configurations Load

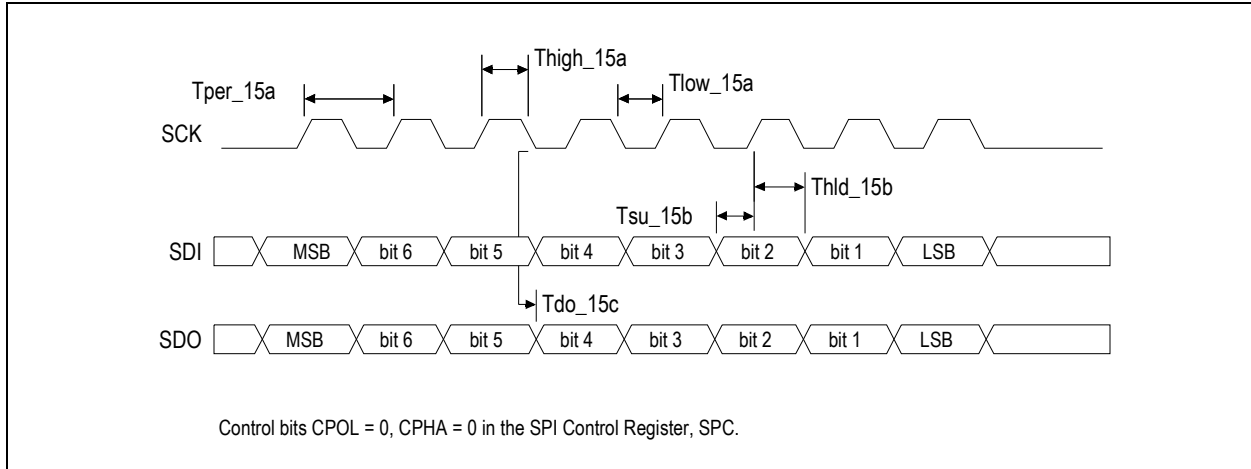

Figure 19 SPI AC Timing Waveform — Clock Polarity 0, Clock Phase 0

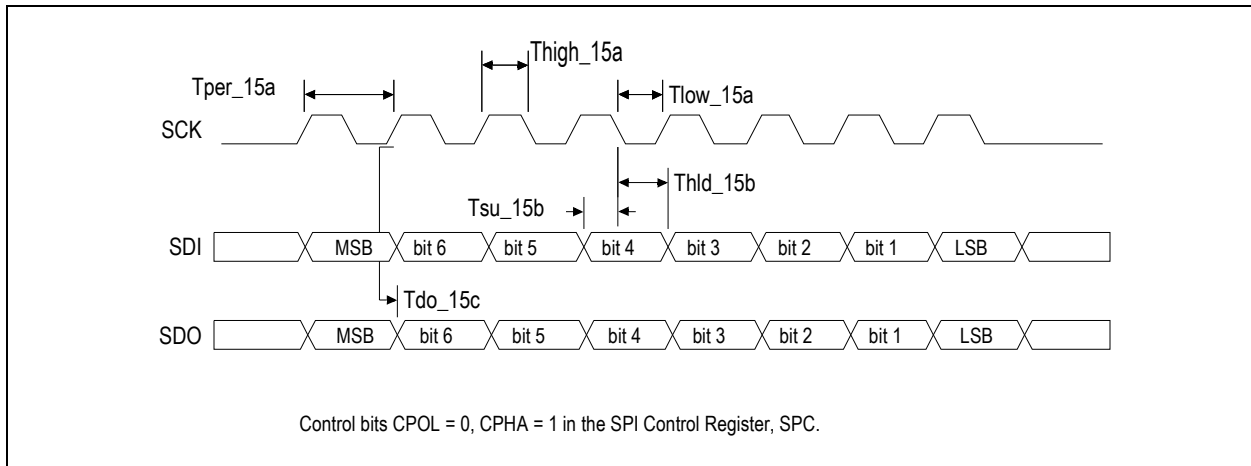

Figure 20 SPI AC Timing Waveform — Clock Polarity 0, Clock Phase 1

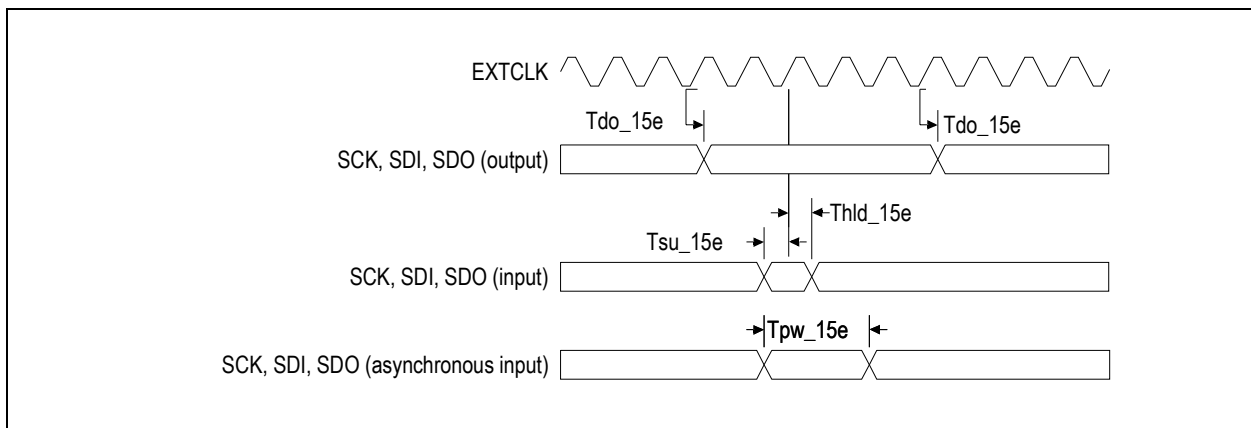

Figure 21 SPI AC Timing Waveform — Bit I/O Mode

Signal	Symbol	Reference Edge	200MHz		233MHz		266MHz		300MHz		Unit	Conditions	Timing Diagram Reference
			Min	Max	Min	Max	Min	Max	Min	Max			
EJTAG and JTAG													
JTAG_TCK	Tper_16a	none	25.0	50.0	25.0	50.0	25.0	50.0	25.0	50.0	ns		See Figure 22.
	Thigh_16a, Tlow_16a		10.0	25.0	10.0	25.0	10.0	25.0	10.0	25.0	ns		
JTAG_TMS ¹ , JTAG_TDI	Tsu_16b	JTAG_TCK rising	2.4	—	2.4	—	2.4	—	2.4	—	ns		
	Thld_16b		1.0	—	1.0	—	1.0	—	1.0	—	ns		
JTAG_TDO	Tdo_16c	JTAG_TCK falling	—	11.3	—	11.3	—	11.3	—	11.3	ns		
	Tdz_16c ²		—	11.3	—	11.3	—	11.3	—	11.3	ns		
JTAG_TRST_N	Tpw_16d ²	none	25.0	—	25.0	—	25.0	—	25.0	—	ns		
EJTAG_TMS ¹	Tsu_16e	JTAG_TCK rising	2.0	—	2.0	—	2.0	—	2.0	—	ns		
	Thld_6e		1.0	—	1.0	—	1.0	—	1.0	—	ns		
VSENSE	Trise_16f	none	—	2	—	2	—	2	—	2	sec	Measured from 0.5V (T _{active})	

Table 14 JTAG AC Timing Characteristics

¹ The JTAG specification, IEEE 1149.1, recommends that both JTAG_TMS and EJTAG_TMS should be held at 1 while the signal applied at JTAG_TRST_N changes from 0 to 1. Otherwise, a race may occur if JTAG_TRST_N is deasserted (going from low to high) on a rising edge of JTAG_TCK when either JTAG_TMS or EJTAG_TMS is low, because the TAP controller might go to either the Run-Test/Idle state or stay in the Test-Logic-Reset state.

² The values for this symbol were determined by calculation, not by testing.

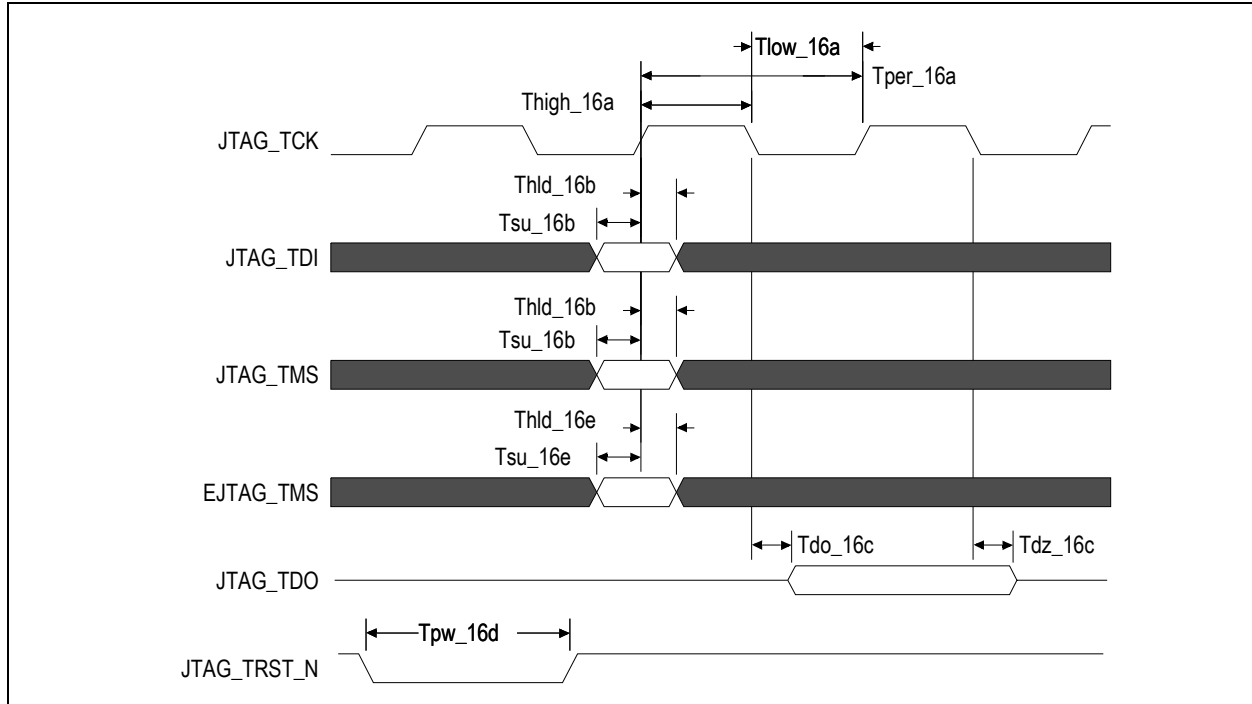

Figure 22 JTAG AC Timing Waveform

The IEEE 1149.1 specification requires that the JTAG and EJTAG TAP controllers be reset at power-up whether or not the interfaces are used for a boundary scan or a probe. Reset can occur through a pull-down resistor on JTAG_TRST_N if the probe is not connected. However, on-chip pull-up resistors are implemented on the RC32438 due to an IEEE 1149.1 requirement. Having on-chip pull-up and external pull-down resistors for the JTAG_TRST_N signal requires special care in the design to ensure that a valid logical level is provided to JTAG_TRST_N, such as using a small external pull-down resistor to ensure this level overrides the on-chip pull-up. An alternative is to use an active power-up reset circuit for JTAG_TRST_N, which drives JTAG_TRST_N low only at power-up and then holds JTAG_TRST_N high afterwards with a pull-up resistor.

Figure 23 shows the electrical connection of the EJTAG probe target system connector.

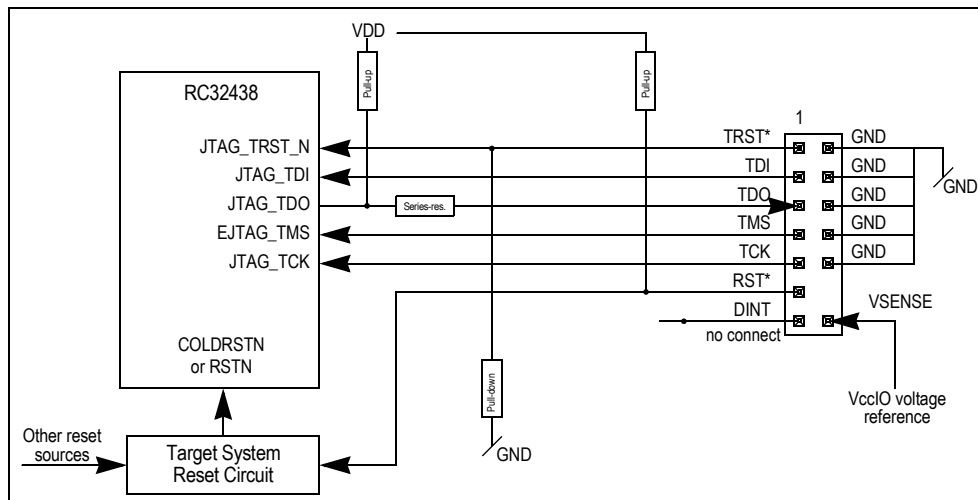

Figure 23 Target System Electrical EJTAG Connection

Using the EJTAG Probe

In Figure 23, the pull-up resistors for JTAG_TDO and RST*, the pull-down resistor for JTAG_TRST_N, and the series resistor for JTAG_TDO must be adjusted to the specific design. However, the recommended pull-up/down resistor is 1.0 k Ω because a low value reduces crosstalk on the cable to the connector, allowing higher JTAG_TCK frequencies. A typical value for the series resistor is 33 Ω . Recommended resistor values have $\pm 5\%$ tolerance.

If a probe is used, the pull-up resistor on JTAG_TDO must ensure that the JTAG_TDO level is high when no probe is connected and the JTAG_TDO output is tri-stated. This requirement allows reliable connection of the probe if it is hooked-up when the power is already on (hot plug). The pull-up resistor value of around 47 k Ω should be sufficient. Optional diodes to protect against overshoot and undershoot voltage can be added on the signals of the chip with EJTAG.

If a probe is used, the RST* signal must have a pull-up resistor because it is controlled by an open-collector (OC) driver in the probe, and thus is actively pulled low only. The pull-up resistor is responsible for the high value when not driven by the probe of 25pF. The input on the target system reset circuit must be able to accept the rise time when the pull-up resistor charges the capacitance to a high logical level. Vcc I/O must connect to a voltage reference that drops rapidly to below 0.5V when the target system loses power, even with a capacitive load of 25pF. The probe can thus detect the lost power condition.

For additional information on EJTAG, refer to Chapter 20 of the RC32438 User Reference Manual.

Voltage Sense Signal Timing

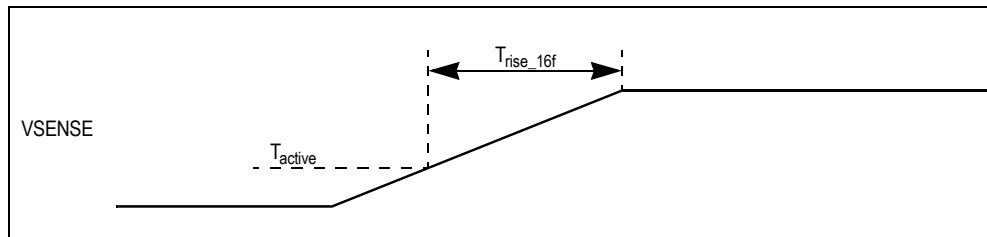

Figure 24 Voltage Sense Signal Timing

The target system must ensure that T_{rise} is obeyed after the system reaches 0.5V (T_{active}), so the probe can use this value to determine when the target has powered-up. The probe is allowed to measure the T_{rise} time from a higher value than T_{active} (but lower than Vcc I/O minimum) because the stable indication in this case comes later than the time when target power is guaranteed to be stable. If JTAG_TRST_N is asserted by a pulse at power-up, this reset must be completed after T_{rise} . If JTAG_TRST_N is asserted by a pull-down resistor, the probe will control JTAG_TRST_N. At power-down, no power is indicated to the probe when Vcc I/O drops under the T_{active} value, which the probe uses to stop driving the input signals, except for the probe RST*.

Phase-Locked Loop (PLL)

The phase-locked loop (PLL) multiplies the external oscillator input (pin CLK) according to the parameter provided by the boot configuration vector to create the processor clock (PCLK). Inherently, PLL circuits are only capable of generating clock frequencies within a limited range.

PLL Filters

It is recommended that the system designer provide a filter network of passive components for the PLL analog and digital power supplies.

The PLL circuit power and PLL circuit ground should be isolated from power and ground with a filter circuit such as the one shown in Figure 25.

Because the optimum values for the filter components depend upon the application and the system noise environment, these values should be considered as starting points for further experimentation within your specific application.

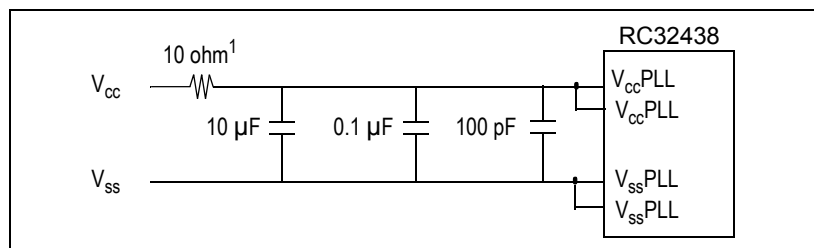

Figure 25 PLL Filter Circuit for Noisy Environments

Recommended Operating Supply Voltages

Symbol	Parameter	Clock Speed	Minimum	Typical	Maximum	Unit
V_{ss}	Common ground	All speeds	0	0	0	V
V_{ss}^{PLL}	PLL ground					
$V_{cc}^{I/O}$	I/O supply except for SSTL_2 ¹		3.0	3.3	3.6	V
$V_{cc}^{SI/O}$	I/O supply for SSTL_2 ¹		2.3	2.5	2.7	V
V_{cc}^{PLL}	PLL supply	200MHz, 233MHz	1.1	1.2	1.3	V
		266MHz, 300MHz	1.2	1.3	1.4	V
V_{cc}^{Core}	Internal logic supply	200MHz, 233MHz	1.1	1.2	1.3	V
		266MHz, 300MHz	1.2	1.3	1.4	V
$DDRREF^2$	SSTL_2 input reference voltage	All speeds	$0.5(V_{cc}^{SI/O})$	$0.5(V_{cc}^{SI/O})$	$0.5(V_{cc}^{SI/O})$	V
V_{TT}^3	SSTL_2 termination voltage		$DDRREF - 0.04$	$DDRREF$	$DDRREF + 0.04$	V

Table 15 RC32438 Operating Voltages

¹ SSTL_2 I/Os are used to connect to DDR SDRAM.

² Peak-to-peak AC noise on DDRVREF may not exceed $\pm 2\%$ DDRVREF (DC).

³ V_{TT} of the SSTL_2 transmitting device must track DDRVREF of the receiving device.

Recommended Operating Temperatures

Grade	Temperature
Commercial	0°C to +70°C Ambient
Industrial	-40°C to +85°C Ambient

Table 16 RC32438 Operating Temperatures

Capacitive Load Deration

Refer to the [79RC32438 IBIS Model](http://www.idt.com) on the IDT web site (www.idt.com).

Power-on Sequence

Three power-on sequences are given below. Sequence #1 is recommended because it will prevent I/O conflicts and will also allow the input signals to propagate when the I/O powers are brought up.

Note: The ESD diodes may be damaged if one of the voltages is applied and one of the other voltages is at a ground level.

A. Recommended Sequence

$t_2 > 0$ whenever possible (V_{ccCore})

$t_1 - t_2$ can be 0 ($V_{ccSI/O}$ followed by $V_{ccI/O}$)

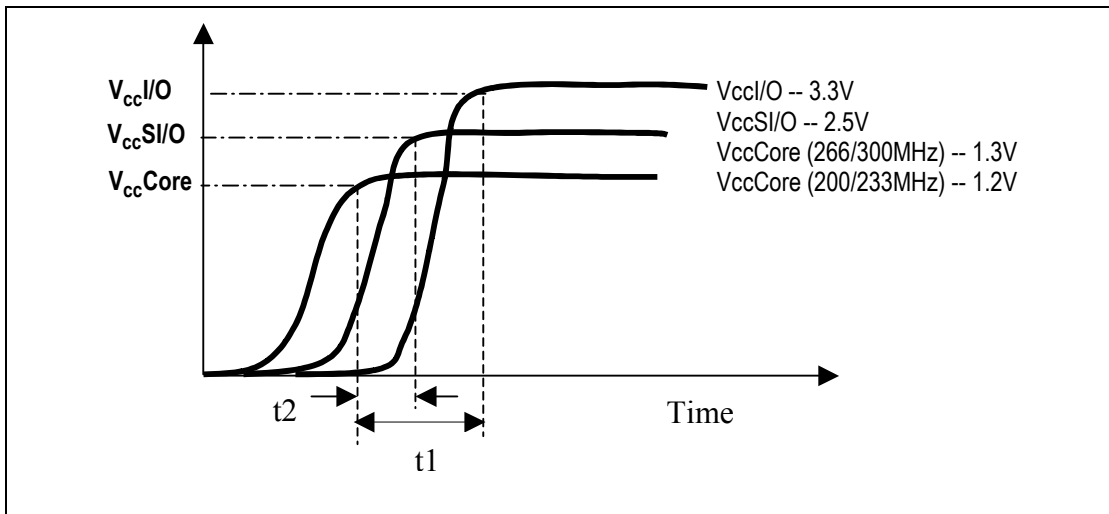

B. Reverse Voltage Sequence

If sequence A is not feasible, then Sequence B can be used:

$t_1 < 50ms$ and $t_2 < 50ms$ to prevent damage.

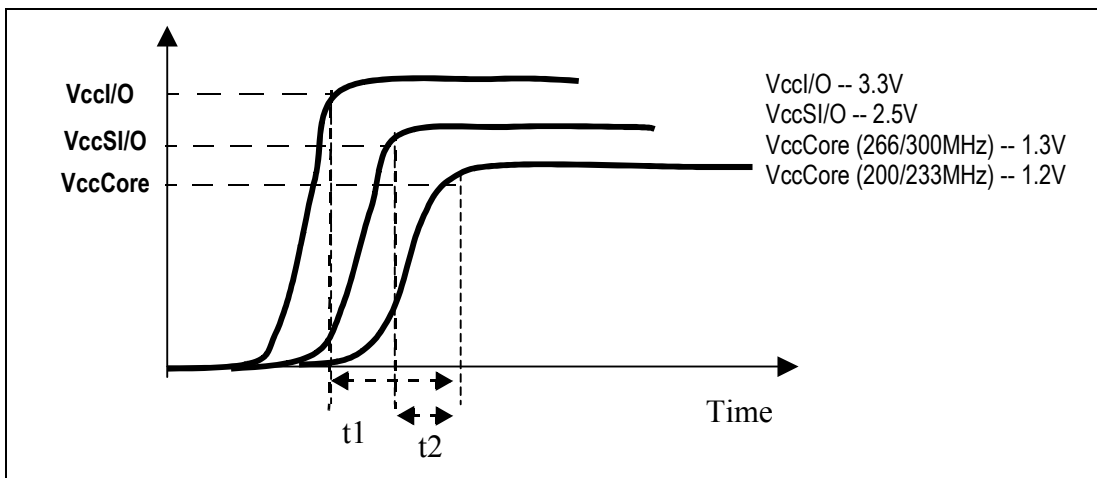

C. Simultaneous Power-up

$V_{ccI/O}$, $V_{ccSI/O}$, and V_{ccCore} can be powered up simultaneously.

Power Consumption

Parameter		200MHz		233MHz		266MHz		300MHz		Unit	Conditions
		Typ.	Max.	Typ.	Max.	Typ.	Max.	Typ.	Max.		
I_{cc} I/O		130	150	180	200	220	250	260	300	mA	$C_L = 35$ pF $T_{ambient} = 25^\circ\text{C}$ Max. values use the maximum volt- ages listed in Table 15. Typical values use the typical voltages listed in that table.
I_{cc} SI/O		100	120	150	170	200	220	250	270	mA	
I_{cc} Core, I_{cc} PLL	Normal mode	460	500	510	550	610	650	680	730	mA	
Power Dissipation	Normal mode	1.2	1.6	1.6	1.9	2.0	2.4	2.4	2.7	W	

Table 17 RC32438 Power Consumption

DC Electrical Characteristics

Values based on systems running at recommended supply voltages, as shown in Table 15.

Note: See Table 2, Pin Characteristics, for a complete I/O listing.

I/O Type	Parameter	Min.	Typical	Max.	Unit	Conditions
LOW Drive Output	I_{OL}	—	14.0	—	mA	$V_{OL} = 0.4\text{V}$
	I_{OH}	—	-12.0	—	mA	$V_{OH} = 1.5\text{V}$
HIGH Drive Output	I_{OL}	—	24.0	—	mA	$V_{OL} = 0.4\text{V}$
	I_{OH}	—	-42.0	—	mA	$V_{OH} = 1.5\text{V}$
Schmitt Trigger Input (STI)	V_{IL}	-0.3	—	0.8	V	—
	V_{IH}	2.0	—	$V_{cc}/O + 0.5$	V	—
SSTL_2 (for DDR SDRAM)	I_{OL}	7.6	—	—	mA	$V_{OL} = 0.5\text{V}$
	I_{OH}	-7.6	—	—	mA	$V_{OH} = 1.76\text{V}$
	V_{IL}	-0.3	—	$0.5(V_{cc}/O) - 0.18$	V	
	V_{IH}	$0.5(V_{cc}/O) + 0.18$	—	$V_{cc}/O + 0.3$	V	

Table 18 DC Electrical Characteristics (Part 1 of 2)

I/O Type	Parameter	Min.	Typical	Max.	Unit	Conditions
PCI	I _{OH} (AC) Switching	-12(V _{cc} I/O)	—	—	mA	0 < V _{OUT} < 0.3(V _{cc} I/O)
		-17.1(V _{cc} I/O - V _{OUT})	—	—	mA	0.3(V _{cc} I/O) < V _{OUT} < 0.9(V _{cc} I/O)
		—	—	-32(V _{cc} I/O)	—	0.7(V _{cc} I/O)
	I _{OL} (AC) Switching	+16(V _{cc} I/O)	—	—	mA	V _{cc} I/O > V _{OUT} > 0.6(V _{cc} I/O)
		+26.7(V _{OUT})	—	—	mA	0.6(V _{cc} I/O) > V _{OUT} > 0.1(V _{cc} I/O)
		—	—	+38(V _{cc} I/O)	mA	V _{OUT} = 0.18(V _{cc} I/O)
	V _{IL}	-0.3	—	0.3(V _{cc} I/O)	V	
	V _{IH}	0.5(V _{cc} I/O)	—	5.5	V	
Capacitance	C _{IN}	—	—	8.0	pF	—
Leakage	Inputs	—	—	± 10	μA	V _{cc} (max)
	I/O _{LEAK} w/o Pull-ups/downs	—	—	± 10	μA	V _{cc} (max)
	I/O _{LEAK} with Pull-ups/downs	—	—	± 80	μA	V _{cc} (max)

Table 18 DC Electrical Characteristics (Part 2 of 2)

AC Test Conditions

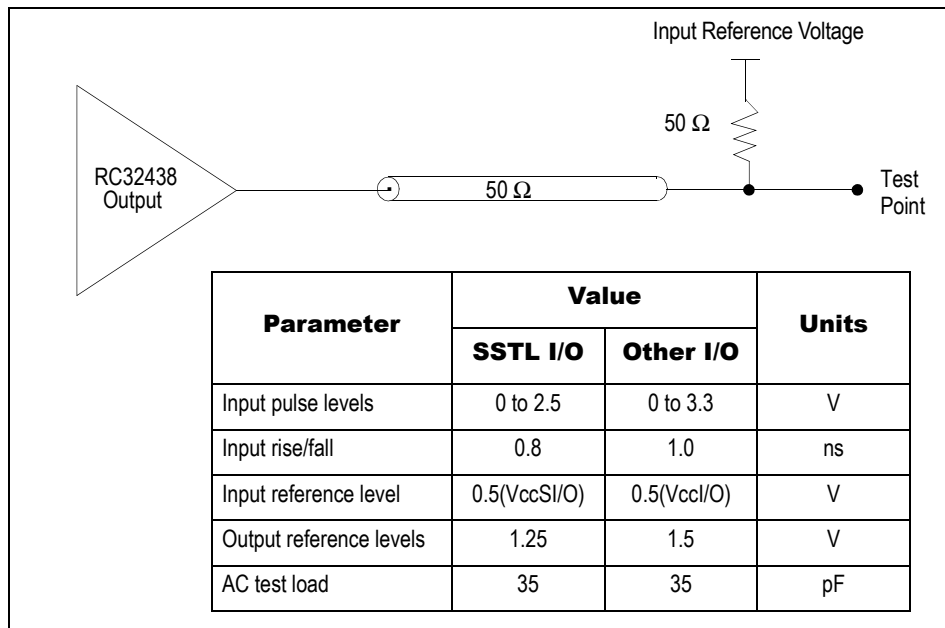

Figure 26 AC Test Conditions

Absolute Maximum Ratings

Symbol	Parameter	Min ¹	Max ¹	Unit
V _{CC} I/O	I/O supply except for SSTL_2 ²	-0.6	4.0	V
V _{CC} SI/O	I/O supply for SSTL_2 ²	-0.6	3.0	V
V _{CC} Core	Core Supply Voltage	-0.6	2.0	V
V _{CC} PLL	PLL supply	-0.6	2.0	V
V _{in} I/O	I/O Input Voltage except for SSTL_2	-0.6	V _{CC} I/O+ 0.5	V
V _{in} SI/O	I/O Input Voltage for SSTL_2	-0.6	V _{CC} SI/O+ 0.5	V
T _a Industrial	Ambient Operating Temperature	-40	+85	°C
T _a Commercial	Ambient Operating Temperature	0	+70	°C
T _s	Storage Temperature	-40	+125	°C

Table 19 Absolute Maximum Ratings

¹ Functional and tested operating conditions are given in Table 15. Absolute maximum ratings are stress ratings only, and functional operation at the maximums is not guaranteed. Stresses beyond those listed may affect device reliability or cause permanent damage to the device.

² SSTL_2 I/Os are used to connect to DDR SDRAM.

Package Pin-out — 416-PBGA Signal Pinout for RC32438

The following table lists the pin numbers, signal names, and number of alternate functions for the RC32438 device. Signal names ending with an “_N” or “N” are active when low.

Pin	Function	Alt	Pin	Function	Alt	Pin	Function	Alt	Pin	Function	Alt
A1	MII0CL		D11	V _{SS}		P1	GPIO[00]	1	AC17	V _{SS}	
A2	GPIO[25]	1	D12	V _{SS}		P2	MIIMDIO		AC18	V _{SS}	
A3	GPIO[31]		D13	V _{CC} Core		P3	GPIO[02]	1	AC19	V _{SS}	
A4	CSN[05]		D14	V _{CC} Core		P4	V _{CC} I/O		AC20	V _{CC} I/O	
A5	CSN[02]		D15	V _{CC} Core		P23	V _{CC} CORE		AC21	V _{CC} I/O	
A6	BWEN[01]		D16	V _{SS}		P24	DDRDM[03]		AC22	V _{CC} I/O	
A7	BOEN		D17	V _{SS}		P25	DDRDATA[31]		AC23	V _{CC} SI/O	
A8	MDATA[15]		D18	V _{SS}		P26	DDRDATA[30]		AC24	V _{CC} SI/O	
A9	MDATA[14]		D19	V _{SS}		R1	INST		AC25	DDROEN[00]	
A10	MDATA[10]		D20	V _{CC} I/O		R2	EJTAG_TMS		AC26	DDRADDR[00]	
A11	MDATA[07]		D21	V _{CC} SI/O		R3	V _{SS}		AD1	JTAG_TRST_N	
A12	MDATA[06]		D22	V _{CC} SI/O		R4	V _{CC} I/O		AD2	JTAG_TMS	
A13	GPIO[29]		D23	V _{CC} SI/O		R23	V _{CC} SI/O		AD3	GPIO[15]	1
A14	GPIO[22]	1	D24	V _{CC} SI/O		R24	DDRDATA[29]		AD4	SDA	
A15	MADDR[21]		D25	DDRDATA[11]		R25	DDRADDR[13]		AD5	GPIO[27]	1
A16	MADDR[19]		D26	DDRDATA[10]		R26	DDRCSN[01]		AD6	PCIAD[30]	
A17	MADDR[16]		E1	MII0TXD[02]		T1	NC		AD7	PCIAD[26]	
A18	MADDR[13]		E2	MII0TXD[00]		T2	GPIO[03]	1	AD8	PCICBEN[03]	
A19	MADDR[10]		E3	MII0TXD[01]		T3	CPU		AD9	PCIAD[21]	
A20	MADDR[07]		E4	V _{SS}		T4	V _{CC} I/O		AD10	PCIAD[18]	
A21	MADDR[05]		E23	V _{CC} SI/O		T23	V _{CC} SI/O		AD11	PCIREQN[01]	
A22	MADDR[02]		E24	DDRDATA[09]		T24	DDRCSN[00]		AD12	PCICLK	
A23	RSTN		E25	DDRDATA[12]		T25	DDRADDR[10]		AD13	PCIGNTN[00]	
A24	DDRDATA[02]		E26	DDRDM[01]		T26	DDRADDR[12]		AD14	PCIIRDYN	
A25	DDRDATA[04]		F1	MII0TXER		U1	JTAG_TDI		AD15	PCISTOPN	
A26	DDRDATA[05]		F2	MII0TXD[03]		U2	JTAG_TCK		AD16	PCIPERRN	
B1	MII0CRS		F3	MII0TXENP		U3	JTAG_TDO		AD17	PCIAD[15]	
B2	WAITACKN		F4	V _{SS}		U4	V _{CC} I/O		AD18	PCIAD[11]	
B3	RWN		F23	V _{CC} SI/O		U23	V _{SS}		AD19	PCIAD[08]	
B4	CSN[04]		F24	DDRQDS[01]		U24	DDRADDR[11]		AD20	PCIAD[06]	
B5	CSN[01]		F25	DDRDATA[15]		U25	DDRWEN		AD21	PCIGNTN[03]	
B6	BWEN[00]		F26	DDRDATA[14]		U26	DDRADDR[09]		AD22	PCIAD[00]	
B7	BGN		G1	MII0RXER		V1	SDO		AD23	PCIAD[04]	
B8	MDATA[13]		G2	MII0RXDV		V2	SDI		AD24	DDRDM[05]	

Table 20 RC32438 416-pin Signal Pin-Out (Part 1 of 3)

Pin	Function	Alt	Pin	Function	Alt	Pin	Function	Alt	Pin	Function	Alt
B9	MDATA[11]		G3	MII0TXCLK		V3	GPIO[05]	1	AD25	DDROEN[02]	
B10	MDATA[03]		G4	V _{ss}		V4	V _{ss}		AD26	DDROEN[01]	
B11	MDATA[08]		G23	V _{ss}		V23	V _{ss}		AE1	N/C	
B12	MDATA[02]		G24	DDRCKP[00]		V24	DDRADDR[08]		AE2	GPIO[13]	1
B13	GPIO[23]	1	G25	DDRDATA[16]		V25	DDRRASN		AE3	GPIO[18]	1
B14	MADDR[20]		G26	DDRDATA[13]		V26	DDRCASN		AE4	GPIO[24]	1
B15	GPIO[20]	1	H1	MII1CRS		W1	GPIO[04]	1	AE5	GPIO[26]	1
B16	MADDR[17]		H2	MII1CL		W2	SCK		AE6	PCIAD[31]	
B17	MADDR[14]		H3	MII1RXCLK		W3	CLK		AE7	PCIAD[28]	
B18	MADDR[12]		H4	V _{ss}		W4	V _{ss}		AE8	PCIAD[25]	
B19	MADDR[09]		H23	V _{ss}		W23	V _{ss}		AE9	GPIO[30]	1
B20	MADDR[06]		H24	DDRCKN[00]		W24	DDRADDR[07]		AE10	PCIAD[22]	
B21	MADDR[03]		H25	DDRDATA[18]		W25	DDRADDR[06]		AE11	PCIAD[19]	
B22	MADDR[00]		H26	DDRVREF		W26	DDRBA[01]		AE12	PCIAD[16]	
B23	DDRDATA[01]		J1	MII1RXD[01]		Y1	GPIO[06]	1	AE13	PCIRSTN	
B24	DDRQS[00]		J2	MII1RXD[00]		Y2	V _{cc} PLL		AE14	PCIREQN[02]	
B25	DDRDM[00]		J3	MII1RXD[03]		Y3	GPIO[08]	1	AE15	PCIFRAMEN	
B26	DDRDATA[06]		J4	V _{ss}		Y4	V _{ss}		AE16	PCIDEVSELN	
C1	MII0RXD[00]		J23	V _{ss}		Y23	V _{ss}		AE17	PCILOCKN	
C2	MII0RXCLK		J24	DDRDATA[17]		Y24	DDRCKN[01]		AE18	PCICBEN[01]	
C3	EXTCLK		J25	DDRDATA[21]		Y25	DDRBA[00]		AE19	PCIAD[13]	
C4	COLDRSTN		J26	DDRDATA[19]		Y26	DDRADDR[05]		AE20	PCIAD[10]	
C5	OEN		K1	MII1RXDV		AA1	V _{ss} PLL		AE21	PCICBEN[00]	
C6	CSN[03]		K2	MII1RXD[02]		AA2	GPIO[07]	1	AE22	PCIAD[05]	
C7	CSN[00]		K3	MII1TXCLK		AA3	V _{cc} PLL		AE23	PCIAD[02]	
C8	BRN		K4	V _{cc} Core		AA4	V _{ss}		AE24	PCIGNTN[01]	
C9	BDIRN		K23	V _{ss}		AA23	V _{ss}		AE25	DDRDM[07]	
C10	MDATA[12]		K24	DDRDATA[20]		AA24	DDRCKP[01]		AE26	DDRDM[04]	
C11	MDATA[09]		K25	DDRQS[02]		AA25	DDRADDR[03]		AF1	GPIO[16]	1
C12	MDATA[01]		K26	DDRCKE		AA26	DDRADDR[04]		AF2	GPIO[17]	1
C13	MDATA[05]		L1	MII1TXD[00]		AB1	GPIO[09]	1	AF3	GPIO[19]	1
C14	MDATA[04]		L2	MII1RXER		AB2	GPIO[14]	1	AF4	SCL	
C15	MDATA[00]		L3	MII1TXD[03]		AB3	GPIO[11]	1	AF5	GPIO[28]	1
C16	GPIO[21]	1	L4	V _{cc} Core		AB4	V _{ss}		AF6	PCIAD[29]	
C17	MADDR[18]		L23	V _{cc} Core		AB23	V _{ss}		AF7	PCIAD[27]	
C18	MADDR[15]		L24	DDRDM[02]		AB24	V _{cc} SI/O		AF8	PCIAD[24]	
C19	MADDR[11]		L25	DDRDATA[24]		AB25	DDRADDR[01]		AF9	PCIAD[23]	

Table 20 RC32438 416-pin Signal Pin-Out (Part 2 of 3)

Pin	Function	Alt	Pin	Function	Alt	Pin	Function	Alt	Pin	Function	Alt
C20	MADDR[08]		L26	DDRDATA[22]		AB26	DDRADDR[02]		AF10	PCIAD[20]	
C21	MADDR[04]		M1	MII1TXD[02]		AC1	V _{ss} PLL		AF11	PCIAD[17]	
C22	MADDR[01]		M2	MII1TXD[01]		AC2	GPIO[10]	1	AF12	PCIREQN[03]	
C23	DDRDATA[00]		M3	MIIMDC		AC3	GPIO[12]	1	AF13	PCIREQN[00]	
C24	DDRDATA[03]		M4	V _{cc} Core		AC4	V _{ss}		AF14	PCICBEN[02]	
C25	DDRDATA[08]		M23	V _{cc} Core		AC5	V _{ss}		AF15	PCITRDYN	
C26	DDRDATA[07]		M24	DDRDATA[23]		AC6	V _{ss}		AF16	PCISERRN	
D1	MIIORXD[03]		M25	DDRDATA[27]		AC7	V _{cc} I/O		AF17	PCIPAR	
D2	MIIORXD[01]		M26	DDRDATA[25]		AC8	V _{cc} I/O		AF18	PCIAD[14]	
D3	MIIORXD[02]		N1	MII1TXER		AC9	V _{cc} I/O		AF19	PCIAD[12]	
D4	V _{ss}		N2	MII1TXENP		AC10	V _{ss}		AF20	PCIAD[09]	
D5	V _{ss}		N3	GPIO[01]	1	AC11	V _{ss}		AF21	PCIAD[07]	
D6	V _{ss}		N4	V _{cc} Core		AC12	V _{ss}		AF22	PCIAD[03]	
D7	V _{cc} I/O		N23	V _{cc} Core		AC13	V _{cc} Core		AF23	PCIAD[01]	
D8	V _{cc} I/O		N24	DDRDATA[26]		AC14	V _{cc} Core		AF24	PCIGNTN[02]	
D9	V _{cc} I/O		N25	DDRDATA[28]		AC15	V _{cc} Core		AF25	DDRDM[06]	
D10	V _{ss}		N26	DDRQDS[03]		AC16	V _{ss}		AF26	DDROEN[03]	

Table 20 RC32438 416-pin Signal Pin-Out (Part 3 of 3)

RC32438 Power Pins

V _{cc} I/O	V _{cc} SI/O	V _{cc} Core	V _{cc} PLL
D7	D21	D13	Y2, AA3
D8	D22	D14	
D9	D23	D15	
D20	D24	K4	
P4	E23	L4	
R4	F23	L23	
T4	R23	M4	
U4	T23	M23	
AC7	AB24	N4	
AC8	AC23	N23	
AC9	AC24	P23	
AC20		AC13	
AC21		AC14	
AC22		AC15	

Table 21 RC32438 Power Pins

RC32438 Ground Pins

V_{SS}	V_{SS}	V_{SS}	V_{SS}	V_{SS} PLL
D4	L10	P13	U15	AA1, AC1
D5	L11	P14	U16	
D6	L12	P15	U17	
D10	L13	P16	U23	
D11	L14	P17	V4	
D12	L15	R3	V23	
D16	L16	R10	W4	
D17	L17	R11	W23	
D18	M10	R12	Y4	
D19	M11	R13	Y23	
E4	M12	R14	AA4	
F4	M13	R15	AA23	
G4	M14	R16	AB4	
G23	M15	R17	AB23	
H4	M16	T10	AC4	
H23	M17	T11	AC5	
J4	N10	T12	AC6	
J23	N11	T13	AC10	
K10	N12	T14	AC11	
K11	N13	T15	AC12	
K12	N14	T16	AC16	
K13	N15	T17	AC17	
K14	N16	U10	AC18	
K15	N17	U11	AC19	
K16	P10	U12		
K17	P11	U13		
K23	P12	U14		

Table 22 RC32438 Ground Pins

RC32438 Alternate Signal Functions

Pin	GPIO	Alternate	Pin	GPIO	Alternate	Pin	GPIO	Alternate
A14	GPIO[22]	MADDR[24]	Y1	GPIO[06]	U0RTSN	AE2	GPIO[13]	U1CTSN
B13	GPIO[23]	MADDR[25]	Y3	GPIO[08]	U1SOUT	AE3	GPIO[18]	DMAFINN[0]
B15	GPIO[20]	MADDR[22]	AA2	GPIO[07]	U0CTSN	AE4	GPIO[24]	PCIREQN[4]
C16	GPIO[21]	MADDR[23]	AB1	GPIO[09]	U1SINP	AE5	GPIO[26]	PCIGNTN[4]
N3	GPIO[01]	U0SINP	AB2	GPIO[14]	DMAREQN[0]	AE9	GPIO[30]	PCIMUINTN
P1	GPIO[00]	U0SOUT	AB3	GPIO[11]	U1DSRN	AF1	GPIO[16]	DMADONE[0]
P3	GPIO[02]	U0RIN	AC2	GPIO[10]	U1DTRN	AF2	GPIO[17]	DMADONE[1]
T2	GPIO[03]	U0DCDN	AC3	GPIO[12]	U1RTSN	AF3	GPIO[19]	DMAFINN[1]
V3	GPIO[05]	U0DSRN	AD3	GPIO[15]	DMAREQN[1]	AF5	GPIO[28]	PCIGNTN[5]
W1	GPIO[04]	U0DTRN	AD5	GPIO[27]	PCIREQN[5]			

Table 23 RC32438 Alternate Signal Functions

RC32438 Signals Listed Alphabetically

The following table lists the RC32438 pins in alphabetical order.

Signal Name	I/O Type	Location	Signal Category
BDIRN	O	C9	Memory and Peripheral Bus
BGN	O	B7	Memory and Peripheral Bus
BOEN	O	A7	Memory and Peripheral Bus
BRN	I	C8	Memory and Peripheral Bus
BWEN[00]	O	B6	Memory and Peripheral Bus
BWEN[01]	O	A6	Memory and Peripheral Bus
CLK	I	W3	System
COLDRSTN	I	C4	System
CPU	O	T3	Debug
CSN[00]	O	C7	Memory and Peripheral Bus
CSN[01]	O	B5	
CSN[02]	O	A5	
CSN[03]	O	C6	
CSN[04]	O	B4	
CSN[05]	O	A4	

Table 24 RC32438 Alphabetical Signal List (Part 1 of 9)

Signal Name	I/O Type	Location	Signal Category
DDRADDR[00]	O	AC26	DDR Bus
DDRADDR[01]	O	AB25	
DDRADDR[02]	O	AB26	
DDRADDR[03]	O	AA25	
DDRADDR[04]	O	AA26	
DDRADDR[05]	O	Y26	
DDRADDR[06]	O	W25	
DDRADDR[07]	O	W24	
DDRADDR[08]	O	V24	
DDRADDR[09]	O	U26	
DDRADDR[10]	O	T25	
DDRADDR[11]	O	U24	
DDRADDR[12]	O	T26	
DDRADDR[13]	O	R25	
DDRBA[00]	O	Y25	
DDRBA[01]	O	W26	
DDRCASN	O	V26	
DDRCKE	O	K26	
DDRCKN[00]	O	H24	
DDRCKN[01]	O	Y24	
DDRCKP[00]	O	G24	
DDRCKP[01]	O	AA24	
DDRCSN[00]	O	T24	
DDRCSN[01]	O	R26	
DDRDATA[00]	I/O	C23	
DDRDATA[01]	I/O	B23	
DDRDATA[02]	I/O	A24	
DDRDATA[03]	I/O	C24	
DDRDATA[04]	I/O	A25	
DDRDATA[05]	I/O	A26	
DDRDATA[06]	I/O	B26	
DDRDATA[07]	I/O	C26	
DDRDATA[08]	I/O	C25	
DDRDATA[09]	I/O	E24	
DDRDATA[10]	I/O	D26	

Table 24 RC32438 Alphabetical Signal List (Part 2 of 9)

Signal Name	I/O Type	Location	Signal Category
DDRDATA[11]	I/O	D25	DDR Bus
DDRDATA[12]	I/O	E25	
DDRDATA[13]	I/O	G26	
DDRDATA[14]	I/O	F26	
DDRDATA[15]	I/O	F25	
DDRDATA[16]	I/O	G25	
DDRDATA[17]	I/O	J24	
DDRDATA[18]	I/O	H25	
DDRDATA[19]	I/O	J26	
DDRDATA[20]	I/O	K24	
DDRDATA[21]	I/O	J25	
DDRDATA[22]	I/O	L26	
DDRDATA[23]	I/O	M24	
DDRDATA[24]	I/O	L25	
DDRDATA[25]	I/O	M26	
DDRDATA[26]	I/O	N24	
DDRDATA[27]	I/O	M25	
DDRDATA[28]	I/O	N25	
DDRDATA[29]	I/O	R24	
DDRDATA[30]	I/O	P26	
DDRDATA[31]	I/O	P25	
DDRDM[00]	O	B25	
DDRDM[01]	O	E26	
DDRDM[02]	O	L24	
DDRDM[03]	O	P24	
DDRDM[04]	O	AE26	
DDRDM[05]	O	AD24	
DDRDM[06]	O	AF25	
DDRDM[07]	O	AE25	
DDRQSQ[00]	I/O	B24	
DDRQSQ[01]	I/O	F24	
DDRQSQ[02]	I/O	K25	
DDRQSQ[03]	I/O	N26	
DDROEN[00]	O	AC25	
DDROEN[01]	O	AD26	

Table 24 RC32438 Alphabetical Signal List (Part 3 of 9)

Signal Name	I/O Type	Location	Signal Category
DDROEN[02]	O	AD25	DDR Bus
DDROEN[03]	O	AF26	
DDRRASN	O	V25	
DDRVREF	I	H26	
DDRWEN	O	U25	
EJTAG_TMS	I	R2	EJTAG/ICE
EXTCLK	O	C3	System
GPIO[00]	I/O	P1	General Purpose Input/Output
GPIO[01]	I/O	N3	
GPIO[02]	I/O	P3	
GPIO[03]	I/O	T2	
GPIO[04]	I/O	W1	
GPIO[05]	I/O	V3	
GPIO[06]	I/O	Y1	
GPIO[07]	I/O	AA2	
GPIO[08]	I/O	Y3	
GPIO[09]	I/O	AB1	
GPIO[10]	I/O	AC2	
GPIO[11]	I/O	AB3	
GPIO[12]	I/O	AC3	
GPIO[13]	I/O	AE2	
GPIO[14]	I/O	AB2	
GPIO[15]	I/O	AD3	
GPIO[16]	I/O	AF1	
GPIO[17]	I/O	AF2	
GPIO[18]	I/O	AE3	
GPIO[19]	I/O	AF3	
GPIO[20]	I/O	B15	
GPIO[21]	I/O	C16	
GPIO[22]	I/O	A14	
GPIO[23]	I/O	B13	
GPIO[24]	I/O	AE4	
GPIO[25]	I/O	A2	
GPIO[26]	I/O	AE5	
GPIO[27]	I/O	AD5	

Table 24 RC32438 Alphabetical Signal List (Part 4 of 9)

Signal Name	I/O Type	Location	Signal Category
GPIO[28]	I/O	AF5	General Purpose Input/Output
GPIO[29]	I/O	A13	
GPIO[30]	I/O	AE9	
GPIO[31]	I/O	A3	
INST	O	R1	Debug
JTAG_TCK	I	U2	EJTAG/ICE
JTAG_TDI	I	U1	
JTAG_TDO	O	U3	
JTAG_TMS	I	AD2	
JTAG_TRST_N	I	AD1	
MADDR[00]	O	B22	Memory and Peripheral Bus
MADDR[01]	O	C22	
MADDR[02]	O	A22	
MADDR[03]	O	B21	
MADDR[04]	O	C21	
MADDR[05]	O	A21	
MADDR[06]	O	B20	
MADDR[07]	O	A20	
MADDR[08]	O	C20	
MADDR[09]	O	B19	
MADDR[10]	O	A19	
MADDR[11]	O	C19	
MADDR[12]	O	B18	
MADDR[13]	O	A18	
MADDR[14]	O	B17	
MADDR[15]	O	C18	
MADDR[16]	O	A17	
MADDR[17]	O	B16	
MADDR[18]	O	C17	
MADDR[19]	O	A16	
MADDR[20]	O	B14	
MADDR[21]	O	A15	
MDATA[00]	I/O	C15	
MDATA[01]	I/O	C12	

Table 24 RC32438 Alphabetical Signal List (Part 5 of 9)

Signal Name	I/O Type	Location	Signal Category
MDATA[02]	I/O	B12	Memory and Peripheral Bus
MDATA[03]	I/O	B10	
MDATA[04]	I/O	C14	
MDATA[05]	I/O	C13	
MDATA[06]	I/O	A12	
MDATA[07]	I/O	A11	
MDATA[08]	I/O	B11	
MDATA[09]	I/O	C11	
MDATA[10]	I/O	A10	
MDATA[11]	I/O	B9	
MDATA[12]	I/O	C10	
MDATA[13]	I/O	B8	
MDATA[14]	I/O	A9	
MDATA[15]	I/O	A8	
MII0CL	I	A1	
MII0CRS	I	B1	
MII0RXCLK	I	C2	
MII0RXD[00]	I	C1	
MII0RXD[01]	I	D2	
MII0RXD[02]	I	D3	
MII0RXD[03]	I	D1	
MII0RXDV	I	G2	
MII0RXER	I	G1	
MII0TXCLK	I	G3	
MII0TXD[00]	O	E2	
MII0TXD[01]	O	E3	
MII0TXD[02]	O	E1	
MII0TXD[03]	O	F2	
MII0TXENP	O	F3	
MII0TXER	O	F1	
MII1CL	I	H2	
MII1CRS	I	H1	
MII1RXCLK	I	H3	
MII1RXD[00]	I	J2	
MII1RXD[01]	I	J1	

Table 24 RC32438 Alphabetical Signal List (Part 6 of 9)

Signal Name	I/O Type	Location	Signal Category
MII1RXD[02]	I	K2	Ethernet Interfaces
MII1RXD[03]	I	J3	
MII1RXDV	I	K1	
MII1RXER	I	L2	
MII1TXCLK	I	K3	
MII1TXD[00]	O	L1	
MII1TXD[01]	O	M2	
MII1TXD[02]	O	M1	
MII1TXD[03]	O	L3	
MII1TXENP	O	N2	
MII1TXER	O	N1	
MIIMDC	O	M3	
MIIMDIO	I/O	P2	
OEN	O	C5	
PCIAD[00]	I/O	AD22	PCI Bus
PCIAD[01]	I/O	AF23	
PCIAD[02]	I/O	AE23	
PCIAD[03]	I/O	AF22	
PCIAD[04]	I/O	AD23	
PCIAD[05]	I/O	AE22	
PCIAD[06]	I/O	AD20	
PCIAD[07]	I/O	AF21	
PCIAD[08]	I/O	AD19	
PCIAD[09]	I/O	AF20	
PCIAD[10]	I/O	AE20	
PCIAD[11]	I/O	AD18	
PCIAD[12]	I/O	AF19	
PCIAD[13]	I/O	AE19	
PCIAD[14]	I/O	AF18	
PCIAD[15]	I/O	AD17	
PCIAD[16]	I/O	AE12	
PCIAD[17]	I/O	AF11	
PCIAD[18]	I/O	AD10	
PCIAD[19]	I/O	AE11	
PCIAD[20]	I/O	AF10	

Table 24 RC32438 Alphabetical Signal List (Part 7 of 9)

Signal Name	I/O Type	Location	Signal Category
PCIAD[21]	I/O	AD9	PCI Bus
PCIAD[22]	I/O	AE10	
PCIAD[23]	I/O	AF9	
PCIAD[24]	I/O	AF8	
PCIAD[25]	I/O	AE8	
PCIAD[26]	I/O	AD7	
PCIAD[27]	I/O	AF7	
PCIAD[28]	I/O	AE7	
PCIAD[29]	I/O	AF6	
PCIAD[30]	I/O	AD6	
PCIAD[31]	I/O	AE6	
PCICBEN[00]	I/O	AE21	
PCICBEN[01]	I/O	AE18	
PCICBEN[02]	I/O	AF14	
PCICBEN[03]	I/O	AD8	
PCICLK	I	AD12	
PCIDEVSELN	I/O	AE16	
PCIFRAMEN	I/O	AE15	
PCIGNTN[00]	I/O	AD13	
PCIGNTN[01]	I/O	AE24	
PCIGNTN[02]	I/O	AF24	
PCIGNTN[03]	I/O	AD21	
PCIIRDYN	I/O	AD14	
PCILOCKN	I/O	AE17	
PCIPAR	I/O	AF17	
PCIPERRN	I/O	AD16	
PCIREQN[00]	I/O	AF13	
PCIREQN[01]	I/O	AD11	
PCIREQN[02]	I/O	AE14	
PCIREQN[03]	I/O	AF12	
PCIRSTN	I/O	AE13	
PCISERRN	I/O	AF16	
PCISTOPN	I/O	AD15	
PCITRDYN	I/O	AF15	
RSTN	I/O	A23	System
RWN	O	B3	Memory and Peripheral Bus





Table 24 RC32438 Alphabetical Signal List (Part 8 of 9)

Signal Name	I/O Type	Location	Signal Category
SCK	I/O	W2	SPI Interface
SCL	I/O	AF4	I ² C
SDA	I/O	AD4	
SDI	I/O	V2	SPI Interface
SDO	I/O	V1	
Vcc CORE		D13, D14, D15, K4, L4, L23, M4, M23, N4, N23, P23, AC13, AC14, AC15	
Vcc I/O, Vcc S/I/O	See Table 21 for a listing of power pins.		
Vcc PLL			
Vss	See Table 22 for a listing of ground pins.		
Vss PLL			
WAITACKN	I	B2	Memory and Peripheral Bus

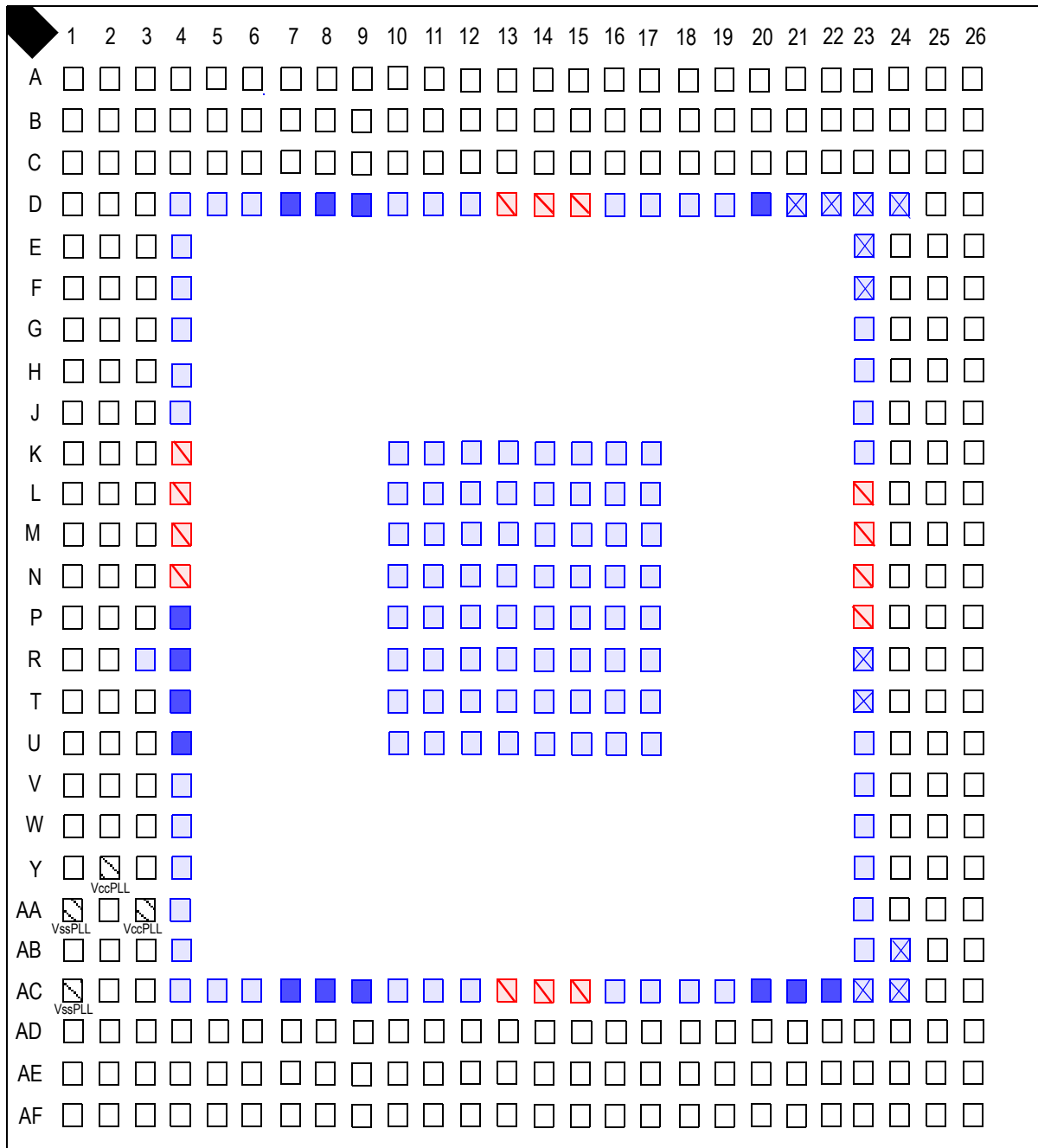
Table 24 RC32438 Alphabetical Signal List (Part 9 of 9)

RC32438 Pinout — Top View



-  Vss (Ground)
-  Vcc SI/O (Power)
-  Vcc I/O (Power)
-  Vcc Core (Power)

RC32438 Package Drawing — Page Two

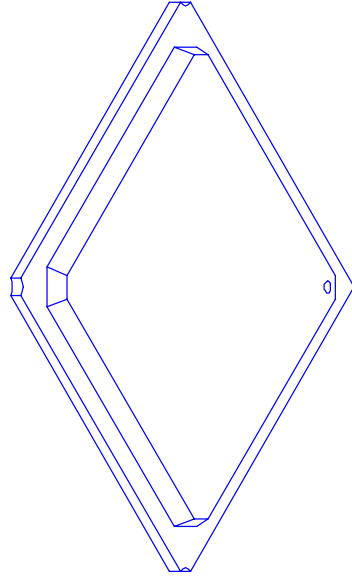

NOTES: UNLESS OTHERWISE SPECIFIED

1. ALL DIMENSIONS AND TOLERANCES CONFORM TO ASME Y14.5M-1994.
2. THE BASIC SOLDER BALL GRID PITCH IS 1.00mm.
3. THE MAXIMUM SOLDER BALL MATRIX SIZE IS 26 X 26. DIMENSION IS MEASURED AT THE MAXIMUM SOLDER BALL DIAMETER, PARALLEL TO PRIMARY DATUM Z.
4. PRIMARY DATUM Z AND SEATING PLANE ARE DEFINED BY THE SPHERICAL CROWNS OF THE SOLDER BALLS.
5. "A1" ID CORNER MUST BE IDENTIFIED. IDENTIFICATION MAY BE BY MEANS OF CHAMFER, METALLIZED OR INK MARK, INDENTATION OR OTHER FEATURE OF THE PACKAGE BODY. MARK MUST BE VISIBLE FROM TOP SURFACE.
- 6.

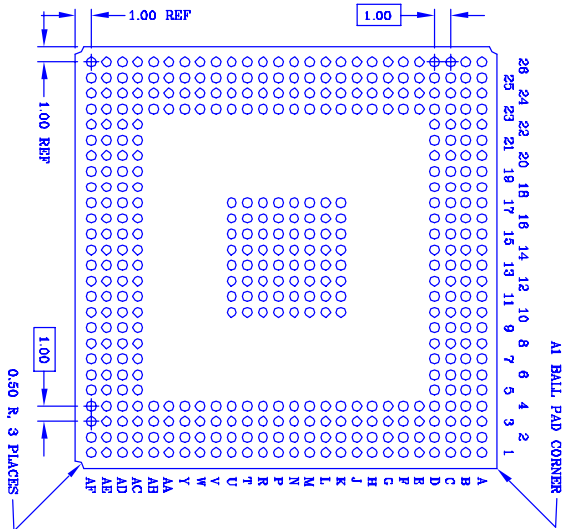

BOTTOM VIEW
(416 SOLDER BALLS)

REVISIONS			
DCN	REV	DESCRIPTION	DATE
	00	INITIAL RELEASE	04/01/02

TOLERANCES UNLESS SPECIFIED		Integrated Device Technology, Inc. 3975 Shaver Way, Santa Clara, CA 95054 PHONE: (408) 727-4116 FAX: (408) 480-8674 TWC: 910-138-2070
XXX.X	ANGULAR 5	
APPROVALS	DATE	TITLE
DRAWN: JSZ	day/mo/yr	BB PACKAGE OUTLINE
CHECKED		PB8A
SIZE	DRAWING No.	REV
C	PSC-4106	00
DO NOT SCALE DRAWING		SHEET 2 OF 2

Ordering Information

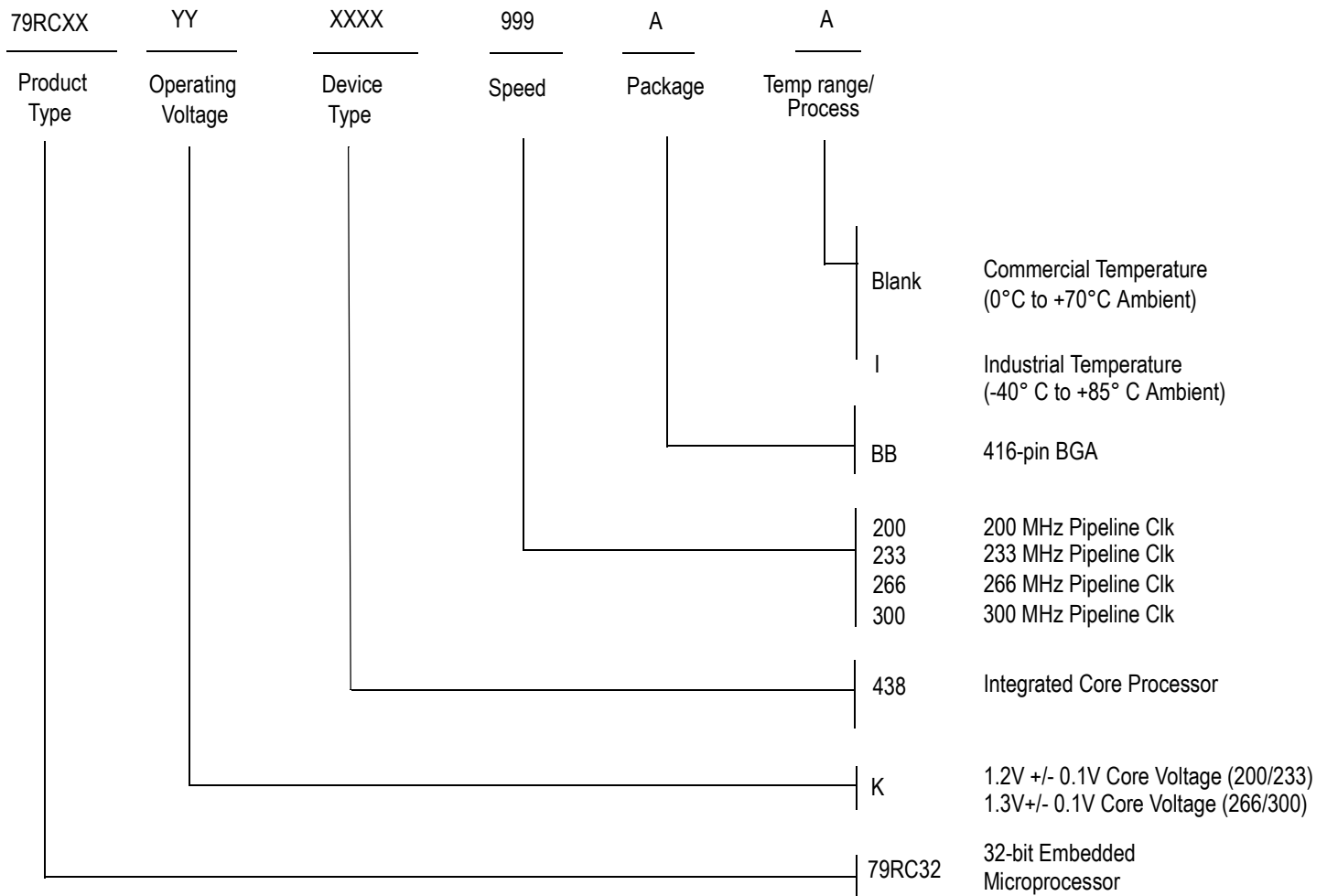

Valid Combinations

79RC32K438 -200BB, 233BB, 266BB, 300BB 416-pin BGA package, Commercial Temperature

79RC32K438 -200BBI, 233BBI 416-pin BGA package, Industrial Temperature



CORPORATE HEADQUARTERS
6024 Silver Creek Valley Road
San Jose, CA 95138

for SALES:
800-345-7015 or 408-284-8200
fax: 408-284-2775
www.idt.com

for Tech Support:
email: rischelp@idt.com
phone: 408-284-8208

Looking for pricing, stock, or lifecycle information?

Click below to explore more details on WIN SOURCE:

-  [View 79RC32K438-300BBG on WIN SOURCE](#)
-  [IDT, Integrated Device Technology Inc Information](#)

Optimize Your Supply Chain with WIN SOURCE Solutions

-  Global Sourcing Solution
-  Obsolete Management
-  Cost Control Management
-  Shortage Management
-  Alternative Solution
-  Excess Inventory Management