



**THE DATASHEET OF
TCA9617ADGKR**



TCA9617A Level-Translating FM+ I²C Bus Repeater

1 Features

- Two-Channel Bidirectional I²C Buffer
- Support for Standard Mode, Fast Mode (400 kHz), and Fast Mode+ (1 Mhz) I²C Operation
- Operating Supply Voltage Range of 0.8 V to 5.5 V on A-Side
- Operating Supply Voltage Range of 2.2 V to 5.5 V on B-Side
- Voltage-Level Translation From 0.8 V to 5.5 V and 2.2 V to 5.5 V
- Footprint and Function Replacement for TCA9517
- Active-High Repeater-Enable Input
- Open-Drain I²C I/O
- 5.5-V Tolerant I²C and Enable Input Support
- Mixed-Mode Signal Operation
- Lockup-Free Operation
- Support for Clock Stretching and Multiple Master Arbitration Across The Device
- Latch-Up Performance Exceeds 100 mA Per JESD 78, Class II
- ESD Protection Exceeds JESD 22
 - 4000-V Human-Body Model (A114-A)
 - 1500-V Charged-Device Model (C101)

2 Applications

- Servers
- Routers (Telecom Switching Equipment)
- Industrial Equipment
- Products With Many I²C Slaves and/or Long PCB Traces

3 Description

The TCA9617A is a BiCMOS dual bidirectional buffer intended for I²C bus and SMBus systems. It can provide bidirectional voltage-level translation (up-translation and down-translation) between low voltages (down to 0.8 V) and higher voltages (2.2 V to 5.5 V) in mixed-mode applications. This device enables I²C and similar bus systems to be extended, without degradation of performance even during level shifting.

The TCA9617A buffers both the serial data (SDA) and the serial clock (SCL) signals on the I²C bus, allowing two buses of 550-pF or greater bus capacitance to be connected in an I²C application. This device can also be used to isolate two halves of a bus for voltage and capacitance.

Device Information⁽¹⁾

PART NUMBER	PACKAGE	BODY SIZE (NOM)
TCA9617A	VSSOP (8)	3.00 mm x 3.00 mm

(1) For all available packages, see the orderable addendum at the end of the datasheet.

Simplified Schematic

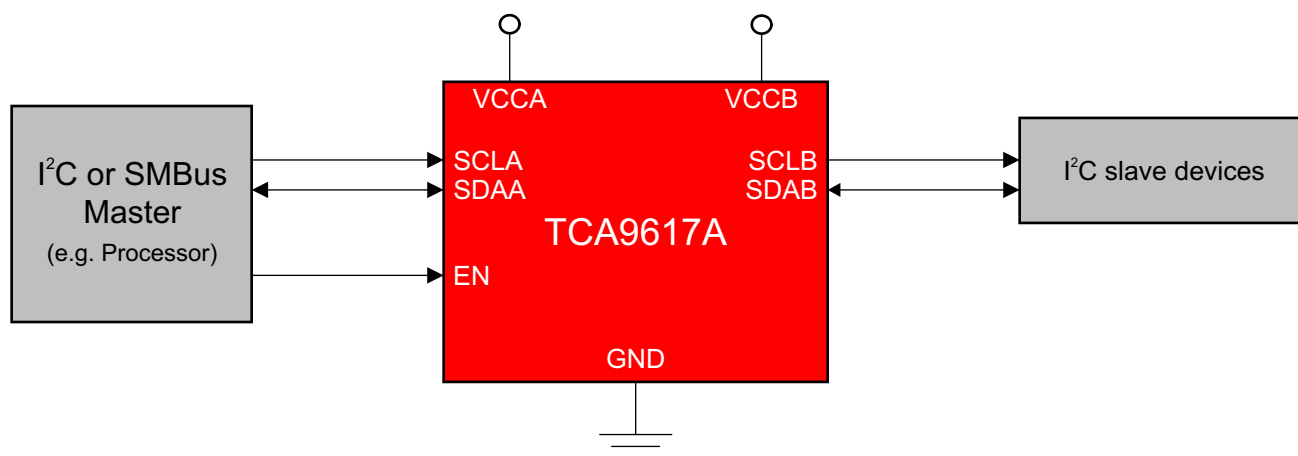

Table of Contents

1 Features	1	8.3 Feature Description.....	10
2 Applications	1	8.4 Device Functional Modes.....	11
3 Description	1	9 Application and Implementation	12
4 Revision History	2	9.1 Application Information.....	12
5 Pin Configuration and Functions	3	9.2 Typical Application	12
6 Specifications	3	10 Power Supply Recommendations	15
6.1 Absolute Maximum Ratings	3	11 Layout	16
6.2 ESD Ratings	4	11.1 Layout Guidelines	16
6.3 Recommended Operating Conditions.....	4	11.2 Layout Example	16
6.4 Thermal Information	4	12 Device and Documentation Support	17
6.5 Electrical Characteristics.....	5	12.1 Receiving Notification of Documentation Updates	17
6.6 Timing Requirements	6	12.2 Community Resource.....	17
6.7 Typical Characteristics	6	12.3 Trademarks	17
7 Parameter Measurement Information	7	12.4 Electrostatic Discharge Caution.....	17
8 Detailed Description	9	12.5 Glossary	17
8.1 Overview	9	13 Mechanical, Packaging, and Orderable	17
8.2 Functional Block Diagram	10	Information	17

4 Revision History

Changes from Revision A (July 2014) to Revision B	Page
• Changed the appearance of the DGK pin out image	3
• Changed the <i>Handling Ratings</i> table to <i>ESD Ratings</i> table	4
• Moved Storage temperature range From the <i>ESD Ratings</i> to the <i>Absolute Maximum Ratings</i> table	4
• Deleted $V_{CCA} < V_{CCB}$ from the Design Requirements list.....	12

Changes from Original (June 2013) to Revision A	Page
• Deleted " Powered-Off High-Impedance I ² C Pins" from Features list.....	1
• Added Applications.	1
• Added <i>Handling Ratings</i> table.....	4
• Added Thermal Information table.	4
• Added Typical Characteristics section.	6
• Added Detailed Description section.	9
• Added Application and Implementation section.	12
• Added Power Supply Recommendations section.	15
• Added Layout section.	16

5 Pin Configuration and Functions

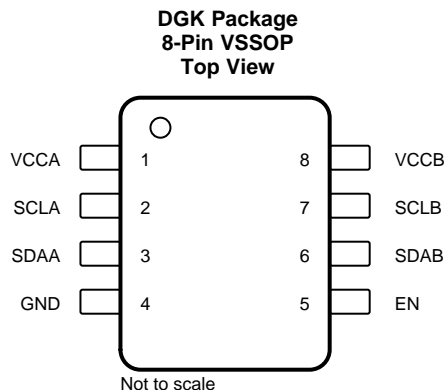

Pin Functions

PIN		DESCRIPTION
NAME	NO.	
VCCA	1	A-side supply voltage (0.8 V to 5.5 V)
SCLA	2	I ² C SCL line, A side. Connect to V _{CCA} through a pull-up resistor.
SDAA	3	I ² C SDA line, A side. Connect to V _{CCA} through a pull-up resistor.
GND	4	Supply ground
EN	5	Active-high repeater enable input
SDAB	6	I ² C SDA line, B side. Connect to V _{CCB} through a pull-up resistor.
SCLB	7	I ² C SCL line, B side. Connect to V _{CCB} through a pull-up resistor.
VCCB	8	B-side and device supply voltage (2.2 V to 5.5 V)

6 Specifications

6.1 Absolute Maximum Ratings⁽¹⁾

over operating free-air temperature range (unless otherwise noted)

		MIN	MAX	UNIT
V _{CCB}	Supply voltage range	-0.5	7	V
V _{CCA}	Supply voltage range	-0.5	7	V
V _I	Enable input voltage range ⁽²⁾	-0.5	7	V
V _{I/O}	I ² C bus voltage range ⁽²⁾	-0.5	7	V
I _{IK}	Input clamp current		-50	mA
I _{OK}	Output clamp current		-50	
I _O	Continuous output current		±50	mA
	Continuous current through V _{CC} or GND		±100	
T _{stg}	Storage temperature range	-65	150	°C

- (1) Stresses beyond those listed under "absolute maximum ratings" may cause permanent damage to the device. These are stress ratings only, and functional operation of the device at these or any other conditions beyond those indicated under "recommended operating conditions" is not implied. Exposure to absolute-maximum-rated conditions for extended periods may affect device reliability.
- (2) The input negative-voltage and output voltage ratings may be exceeded if the input and output current ratings are observed.

6.2 ESD Ratings

			MIN	MAX	UNIT
V _{ESD}	Electrostatic discharge	Human body model (HBM), per ANSI/ESDA/JEDEC JS-001, all pins ⁽¹⁾	0	4000	V
		Charged device model (CDM), per JEDEC specification JESD22-C101, all pins ⁽²⁾	0	1500	

(1) JEDEC document JEP155 states that 500-V HBM allows safe manufacturing with a standard ESD control process.

(2) JEDEC document JEP157 states that 250-V CDM allows safe manufacturing with a standard ESD control process.

6.3 Recommended Operating Conditions

over operating free-air temperature range (unless otherwise noted)

		MIN	MAX	UNIT
V _{CCA}	Supply voltage, A-side bus	0.8	V _{CCB}	V
V _{CCB}	Supply voltage, B-side bus	2.2	5.5	V
I _{OLA}	Low-level output current		30	mA
I _{OLB}	Low-level output current	0.1	30	mA
T _A	Operating free-air temperature	–40	85	°C

6.4 Thermal Information

THERMAL METRIC ⁽¹⁾		TCA9617A	UNIT
		DGK	
		8 PINS	
R _{θJA}	Junction-to-ambient thermal resistance	171.8	°C/W
R _{θJC(top)}	Junction-to-case (top) thermal resistance	61.2	°C/W
R _{θJB}	Junction-to-board thermal resistance	93.6	°C/W
ψ _{JT}	Junction-to-top characterization parameter	7.9	°C/W
ψ _{JB}	Junction-to-board characterization parameter	91.9	°C/W

(1) For more information about traditional and new thermal metrics, see the [Semiconductor and IC Package Thermal Metrics](#) application report.

6.5 Electrical Characteristics

 $V_{CCB} = 2.2\text{ V to }5.5\text{ V}$, $GND = 0\text{ V}$, $T_A = -40^\circ\text{C to }85^\circ\text{C}$ (unless otherwise noted)

PARAMETER		TEST CONDITIONS	V_{CCB}	MIN	TYP	MAX	UNIT
V_{IK}	Input clamp voltage	$I_I = -18\text{ mA}$	2.2 V to 5.5 V			-1.2	V
V_{OL}	Low-level output voltage	SDAB, SCLB $I_{OL} = 100\mu\text{A}$ or 30mA , $V_{ILA} = 0\text{ V}$	2.2 V to 5.5 V	0.48	0.53	0.58	V
		SDAA, SCLA $I_{OL} = 30\text{mA}$			0.1	0.2	
V_{IH}	High-level input voltage	SDAA, SCLA	2.2 V to 5.5 V	$0.7 \times V_{CCA}$		V_{CCB}	V
		SDAB, SCLB		$0.7 \times V_{CCB}$		V_{CCB}	
		EN		$0.7 \times V_{CCB}$		5.5	
V_{IL}	Low-level input voltage	SDAA, SCLA	2.2 V to 5.5 V			$0.3 \times V_{CCA}$	V
		SDAB, SCLB				0.4	
		EN				$0.3 \times V_{CCB}$	
I_{CCA}	Quiescent supply current for V_{CCA}	Both channels low, SDAA = SCLA = GND and SDAB = SCLB = open, or SDAA = SCLA = open and SDAB = SCLB = GND	2.2 V to 5.5 V			13	μA
I_{CCB}	Quiescent supply current	Both Channels high, SDAA = SCLA = V_{CCA} B-side pulled up to V_{CCB} with pullup resistors	5.5 V		+4.5	+7	mA
		Both channels low, SDAA = SCLA = GND, $I_{OLB} = 100\ \mu\text{A}$			+5.7	+8.1	
I_I	Input leakage current	SDAB, SCLB	2.2 V to 5.5 V	$V_I = V_{CCB}$		+1	μA
				$V_I = 0.2\text{ V}$, EN = 0	-10	+10	
				$V_I = V_{CCB} - 0.2\text{ V}$	-1	+1	
		SDAA, SCLA		$V_I = V_{CCA}$	-1	+1	
				$V_I = 0.2\text{ V}$	-10	+10	
				$V_I = V_{CCA} - 0.2\text{ V}$	-1	+1	
		EN		$V_I = V_{CCB}$	-1	+1	
$V_I = 0.2\text{ V}$	-25						
C_I	Input capacitance	EN	$V_I = 3\text{ V}$ or 0 V	3.3 V		7	pF
		SCLA, SCLB	$V_I = 3\text{ V}$ or 0 V	3.3 V		9	
			$V_I = 0\text{ V}$			9	
C_I	Input/output capacitance	SDAA, SDAB	$V_I = 3\text{ V}$ or 0 V	3.3 V		14	pF
			$V_I = 0\text{ V}$			14	

6.6 Timing Requirements

$V_{CCA} = 0.8\text{ V to }5.5\text{ V}$, $V_{CCB} = 2.2\text{ V to }5.5\text{ V}$, $GND = 0\text{ V}$, $T_A = -40^\circ\text{C to }85^\circ$ (unless otherwise noted)⁽¹⁾⁽²⁾

PARAMETER		FROM (INPUT)	TO (OUTPUT)	TEST CONDITIONS	MIN	TYP ⁽³⁾	MAX	UNIT
t_{PLH}	Propagation delay	SDAB, SCLB	SDAA, SCLA		42	55	90	ns
		SDAA, SCLA	SDAB, SCLB	$V_{CCB} \leq 3\text{ V}$	61	88	137	
				$V_{CCB} > 3\text{ V}$	61	94	250	
t_{PHL}	Propagation delay	SDAB, SCLB	SDAA, SCLA		69	93	144	ns
		SDAA, SCLA	SDAB, SCLB		68	90	140	
$t_{TLH}^{(4)}$	Transition time	B side	30%	70%				ns
		A side			88			
t_{THL}	Transition time	B side	70%	30%	5.40	6.41	13.8	ns
		A side			1.40	4.71	11.3	
t_{su}	Setup time, EN high before Start condition ⁽⁵⁾				100			ns

- (1) Times are specified with loads of $240\ \Omega \pm 1\%$ and $400\text{ pF} \pm 10\%$ on B-side and $240\ \Omega \pm 1\%$ and $200\text{ pF} \pm 10\%$ on A-side. Different load resistance and capacitance alter the rise time, thereby changing the propagation delay and transition times.
- (2) Times are specified with A-side signals pulled up to V_{CCA} ; $V_{CCA} = 0.9\text{ V}$ and B-side signals pulled up to V_{CCB} ; $V_{CCB} = 2.5\text{ V}$.
- (3) Typical values were measured with $V_{CCA} = 0.9\text{ V}$ and $V_{CCB} = 2.5\text{ V}$ at $T_A = 25^\circ\text{C}$, unless otherwise noted.
- (4) t_{TLH} is determined by the pullup resistance and load capacitance.
- (5) EN should change state only when the global bus and the repeater port are in an idle state.

6.7 Typical Characteristics

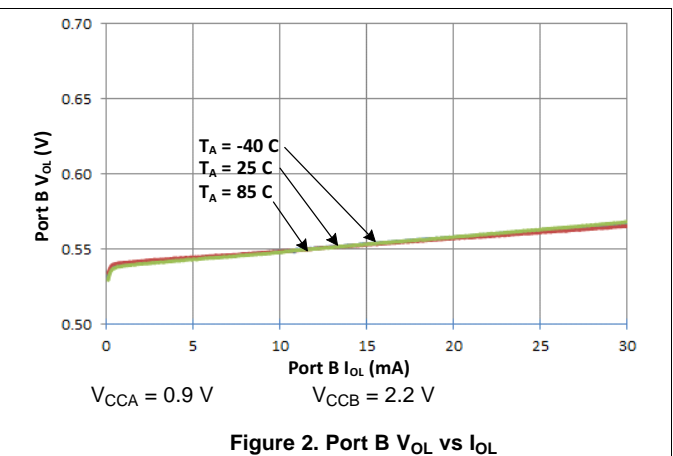
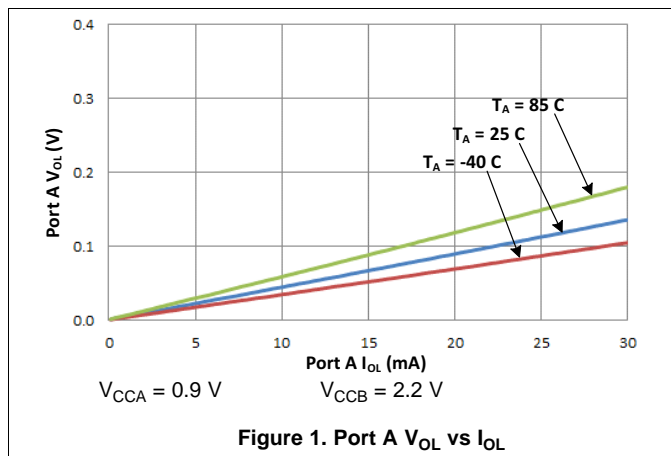

7 Parameter Measurement Information

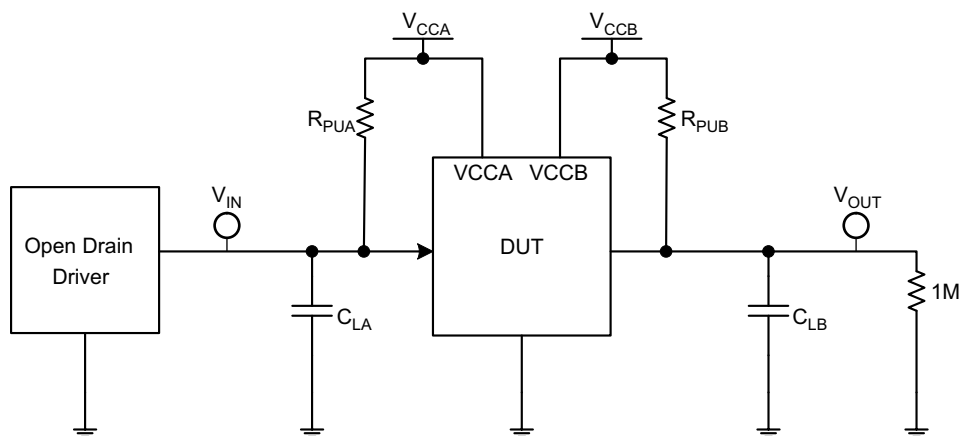
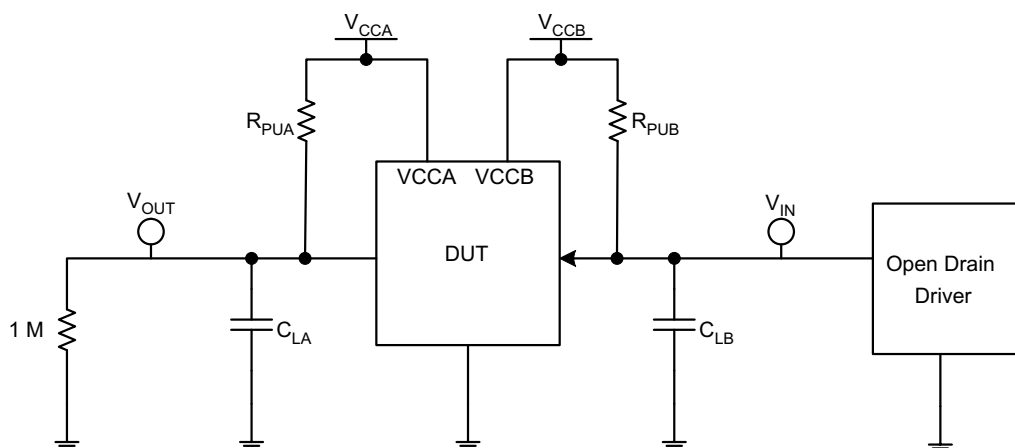

Figure 3. Test Circuit for Open-Drain Output from A to B



- A. $V_{CCA} = 0.9\text{ V}$
- B. $V_{CCB} = 2.5\text{ V}$
- C. $R_{PUA} = R_{PUB} = 240\ \Omega$ on the A-side and the B-side
- D. $C_{LA} = 200\text{ pF}$ on A-side and $C_{LB} = 400\text{ pF}$ on B-side (includes probe and jig capacitance)
- E. All input pulses are supplied by generators having the following characteristics: $PRR \leq 10\text{ MHz}$, $Z_O = 50\ \Omega$, slew rate $\geq 1\text{ V/ns}$
- F. The outputs are measured one at a time, with one transition per measurement.

Figure 4. Test Circuit for Open-Drain Output from B to A

Parameter Measurement Information (continued)

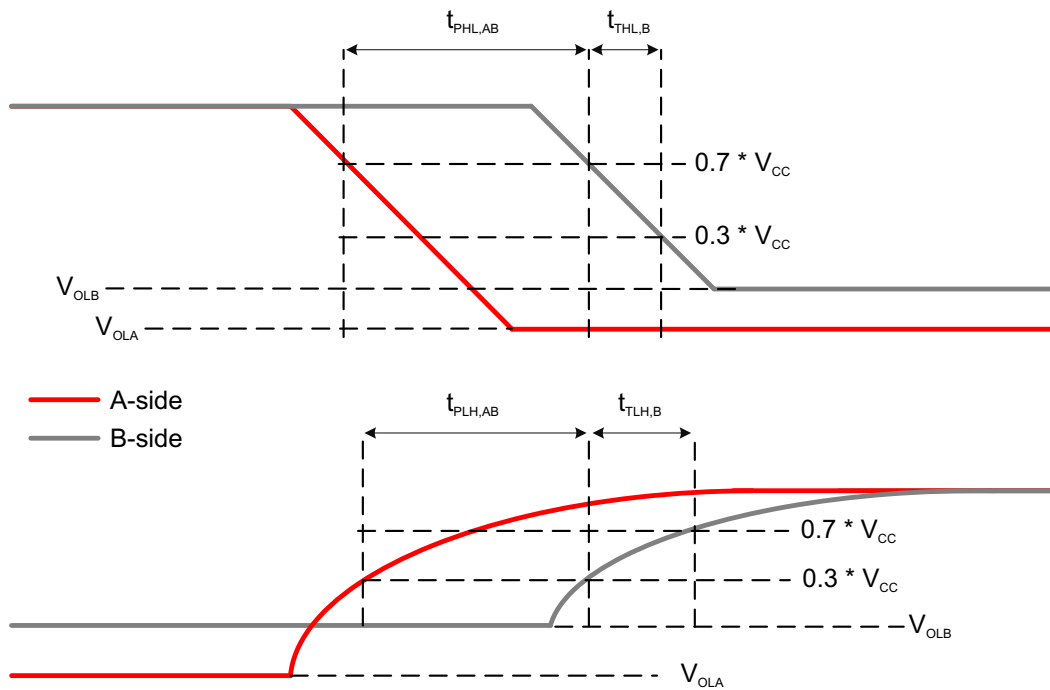

Figure 5. Propagation Delay And Transition Times (A to B)

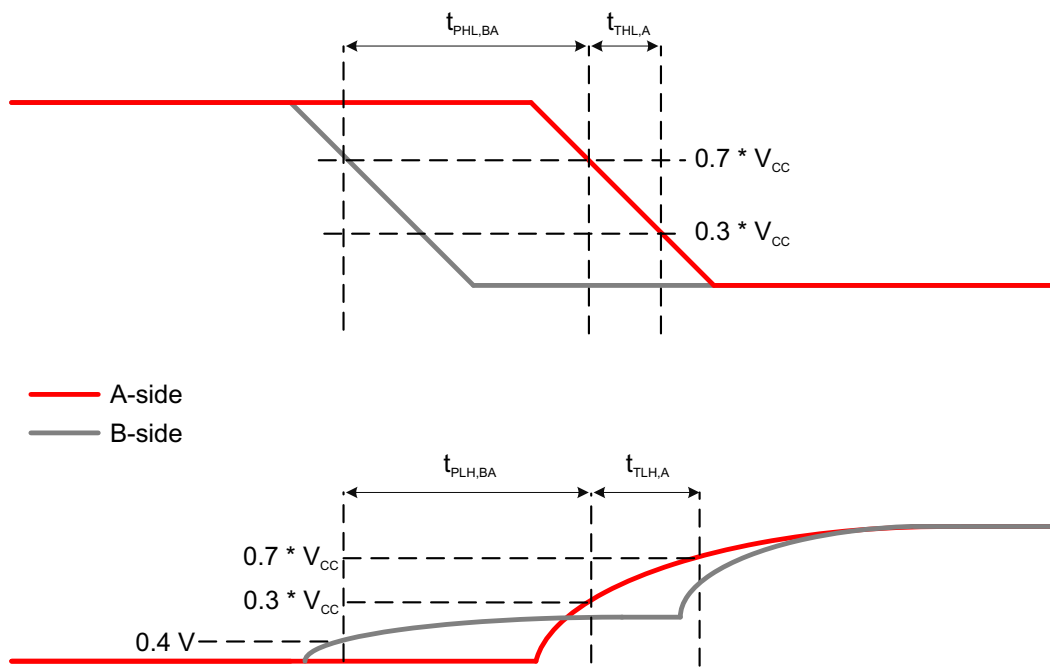

Figure 6. Propagation Delay And Transition Times (B to A)

8 Detailed Description

8.1 Overview

The TCA9617A is a BiCMOS dual bidirectional buffer intended for I²C bus and SMBus systems. As with the standard I²C system, pullup resistors are required to provide the logic high levels on the buffered bus. The TCA9617A has standard open-drain configuration of the I²C bus. The size of these pullup resistors depends on the system, but each side of the repeater must have a pullup resistor. The device is designed to work with Standard mode, Fast mode and Fast Mode+ I²C devices.

The TCA9617A B-side drivers operate from 2.2 V to 5.5 V. The output low level for this internal buffer is approximately 0.5 V, but the input voltage must be 70 mV or more below the output low level when the output is externally driven low. The higher-voltage low signal is called a buffered low. When the B-side I/O is driven low internally, the low is not recognized as a low by the input. This feature prevents a lockup condition from occurring when the input low condition is released. This type of design on the B side prevents it from being used in series with another TCA9617A B-side or other buffers that incorporate a static or dynamic offset voltage. This is because these devices do not recognize buffered low signals as a valid low and do not propagate it as a buffered low again.

The TCA9617A A-side drivers operate from 0.8 V to 5.5 V and do not have the buffered low feature (or the static offset voltage). This means that a low signal on the B side translates to a nearly 0-V low on the A side, which accommodates smaller voltage swings of low-voltage logic. The output pulldown on the A side drives a hard low, and the input level is set to 0.3 V_{CCA} to accommodate the need for a lower low level in systems where the low-voltage-side supply voltage is as low as 0.8 V.

The A side of two or more TCA9617As can be connected together to allow a star topology, with the A side on the common bus. Also, the A side can be connected directly to any other buffer with static or dynamic offset voltage. Multiple TCA9617As can be connected in series, A side to B side, with no buildup in offset voltage with only time-of-flight delays to consider.

The TCA9617A includes a power-up circuit that keeps the output drivers turned off until V_{CCB} is above 2.0 V and V_{CCA} is above 0.7 V. V_{CCA} is only used to provide references for the A-side input comparators and the power-good-detect circuit. The TCA9617A internal circuitry and all I/Os are powered by the V_{CCB} pin; however, due to ESD protection requirements on the SCLA and SDAA, it is required to power-up V_{CCB} prior to V_{CCA}. If SDA and SCL (on A-side or B-side) are pulled up to a positive voltage before V_{CCB} is powered, there can be significant current leakage into the SCA and SCL pins that could cause them to be pulled down. The SDA and SCL lines shall not be pulled up to a voltage higher than V_{CCB}, even when the device is powered down.

After power up and with the EN high, the A side falling below 0.7 V_{CCA} turns on the corresponding B-side driver (either SDA or SCL) and drives the B-side down momentarily to 0 V before settling to approximately 0.5 V. When the A-side rises above 0.3 V_{CCA}, the B-side pulldown driver is turned off and the external pullup resistor pulls the pin high. If the B side falls first and goes below 0.7 V_{CCB}, the A-side driver is turned on and drives the A-side to 0 V. When the B-side rises above 0.45 V, the A-side pulldown driver is turned off and the external pullup resistor pulls the pin high.

8.2 Functional Block Diagram

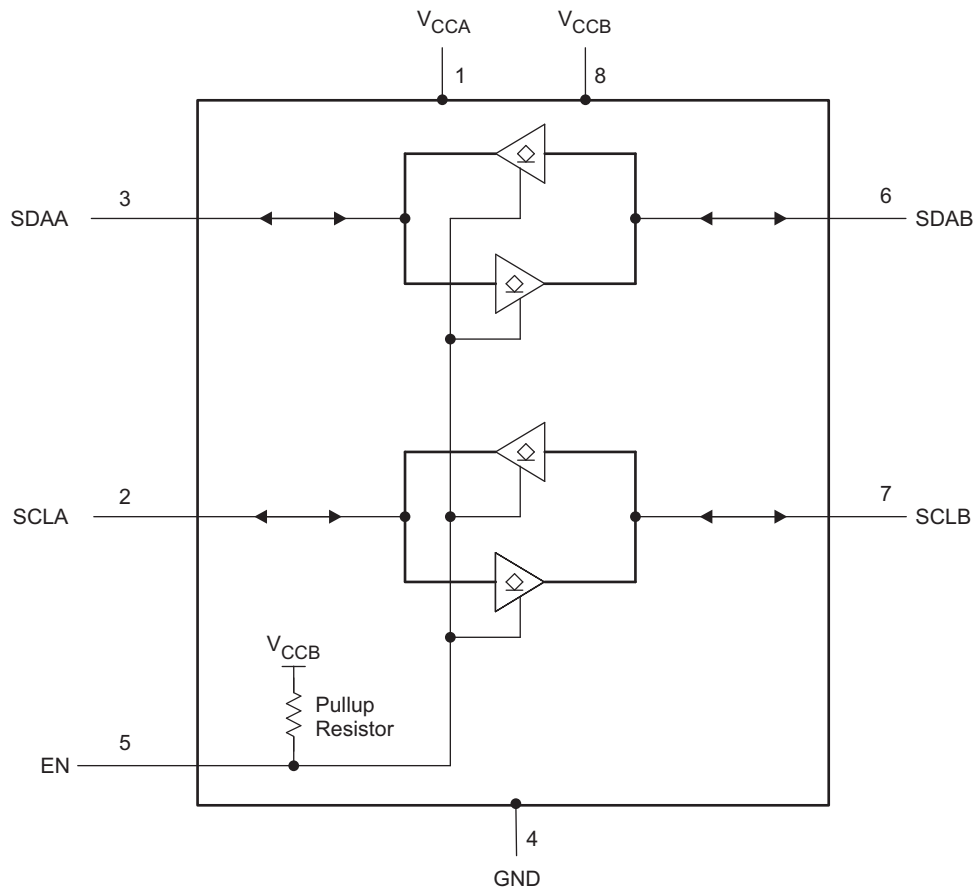

Copyright © 2017, Texas Instruments Incorporated

8.3 Feature Description

8.3.1 Bidirectional Level Translation

The TCA9617A can provide bidirectional voltage level translation (up-translation and down-translation) between low voltages (down to 0.8 V) and higher voltages (2.2 V to 5.5 V) in mixed-mode applications.

8.3.2 V_{OL} B-side Offset Voltage

Figure 8 depicts the offset voltage on the B side of the device. As shown in Figure 8 the slave releases and the B-side rises, and it will rise to 0.5 V and stay there until the A-side rises above $0.3 V_{CCA}$. This effect can cause the low level signal to have a "pedestal." Once the voltage on the A-side crosses $0.3 V_{CCA}$, the B-side will continue to rise to V_{CCB} .

Due to nature of the B-side pedestal and the static offset voltage, there will be a slight overshoot (point 2) as the B-side rises from being externally driven low to the 0.5 V offset. The TCA9617A is designed to control this behavior provided the system is designed with rise times greater than 20 ns. Therefore, care should be taken to limit the pullup strength when devices with rise time accelerators are present on the B side. Excessive overshoot on the B-side pedestal may cause devices with rise time accelerators to trip prematurely if the accelerator thresholds are below $0.3 V_{CCB}$. Since the A-side does not have a static offset low voltage, no pedestal is seen on the A-side as shown in Figure 7.

Feature Description (continued)

8.3.3 High to Low Transition Characteristics

When the A side of the bus is driven to $0.7 V_{CCA}$, the B side driver will turn on. This will drive the B-side to 0 V for a short period (see Figure 8) and then the B-side will rise to the static offset voltage of 0.5 V (V_{OL} of TCA9617A). This effect, called an inverted pedestal, allows the B-side to drive to logic low much faster than driving to the static offset. Driving to the static offset voltage requires that the fall time be slowed to prevent ringing.

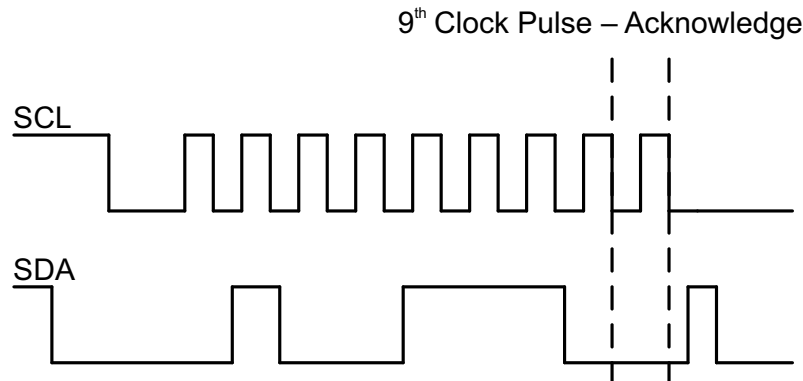

Figure 7. Bus A (0.8 V to 5.5 V Bus) Waveform

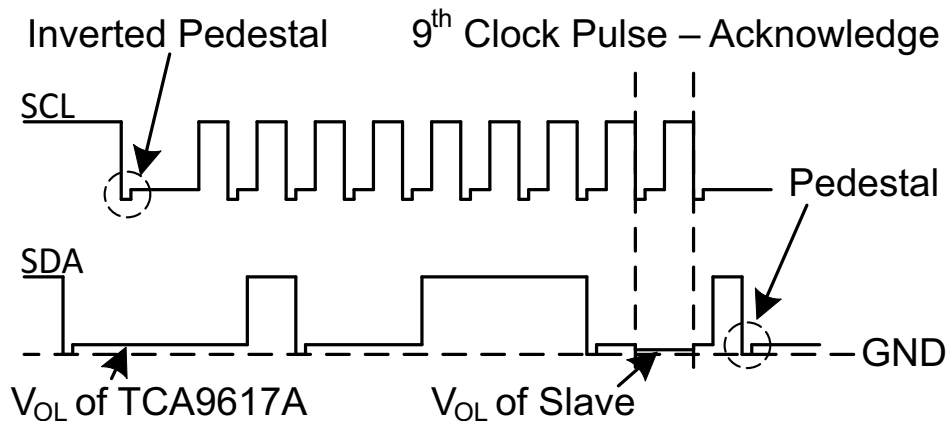

Figure 8. Bus B (2.2 V to 5.5 V Bus) Waveform

8.4 Device Functional Modes

The TCA9617A has an active-high enable (EN) input with an internal pull-up to V_{CCB} , which allows the user to select when the repeater is active. This can be used to isolate a badly behaved slave on power-up reset. It should never change state during an I²C operation, because disabling during a bus operation may hang the bus, and enabling part way through the bus cycles could confuse the I²C parts being enabled. The EN input should change state only when the global bus and repeater port are in the idle state to prevent system failures.

Table 1. Function Table

INPUT EN	FUNCTION
L	Outputs disabled
H	SDAA = SDAB SCLA = SCLB

9 Application and Implementation

9.1 Application Information

A typical application is shown in [Figure 9](#). In this example, the system master is running on a 0.9-V I²C bus, and the slave is connected to a 2.5-V bus. Both buses are running at 400 kHz. Decoupling capacitors are required but are not shown in [Figure 14](#) for simplicity.

The TCA9617A is 5-V tolerant so no additional circuits are required to translate between 0.8-V to 5.5-V bus voltages and 2.7-V to 5.5-V bus voltages.

When the A side of the TCA9617A is pulled low by a driver on the I²C bus, a comparator detects the falling edge when it goes below $0.7 V_{CCA}$ and cause the internal driver on the B side to turn on. The B-side will first pull down to 0 V and then settle to 0.5 V. When the B side of the TCA9617A falls below 0.45 V, the TCA9617A will detect the falling edge, turn on the internal driver on the A side and pull the A-side pin down to ground. In order to illustrate what would be seen for an A to B transition refer to [Figure 11](#), and for a B to A transition see [Figure 10](#).

On the B-side bus of the TCA9617A, the clock and data lines will have a positive offset from ground equal to the V_{OL} of the TCA9617A. After the eighth clock pulse, the data line is pulled to the V_{OL} of the slave device, which is close to ground in this example. At the end of the acknowledge, the level rises only to the low level set by the driver of the TCA9617A for a short delay (approximately 0.5 V), while the A-side bus rises above $0.3 V_{CCA}$ and then continues high.

Although the TCA9617 has a single application, the device can exist in multiple configurations. [Figure 9](#) shows the standard configuration for the TCA9617. Multiple TCA9617s can be connected either in star configuration ([Figure 12](#)) or in series configuration ([Figure 13](#)). The design requirements, detailed design procedure, and application curves in [Standard Application](#) are valid for all three configurations.

9.2 Typical Application

9.2.1 Standard Application

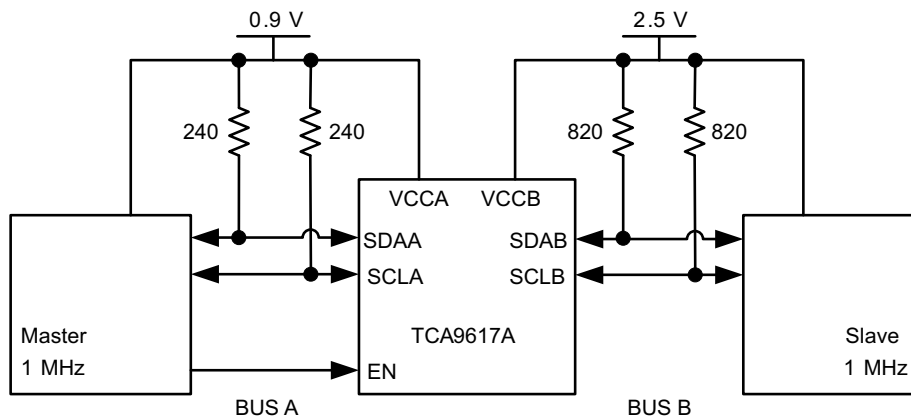

Figure 9. Bidirectional Voltage Level Translator

9.2.1.1 Design Requirements

For the level-translating application, the following should be true:

- $V_{CCA} = 0.8 \text{ V to } 5.5 \text{ V}$
- $V_{CCB} = 2.2 \text{ V to } 5.5 \text{ V}$
- $I_{OL} > I_O$

Typical Application (continued)

9.2.1.2 Detailed Design Procedure

9.2.1.2.1 Pullup Resistor Sizing

For the TCA9617A to function correctly, all devices on the B-side must be able to pull the B-side below the voltage input low contention level (0.45 V). This means that the V_{OL} of any device on the B-side must be below 0.4 V to ensure proper operation.

The V_{OL} of a device can be adjusted by changing the I_{OL} through the device which is set by the pull-up resistor value. The pull-up resistor on the B-side must be carefully selected to ensure that logic levels will be transferred correctly to the A-side.

The B-side pull-up resistor sizing must also ensure that the rise time is greater than 20 ns. Shorter rise times will increase the pedestal overshoot shown in point 2 of Figure 10.

9.2.1.3 Application Curves

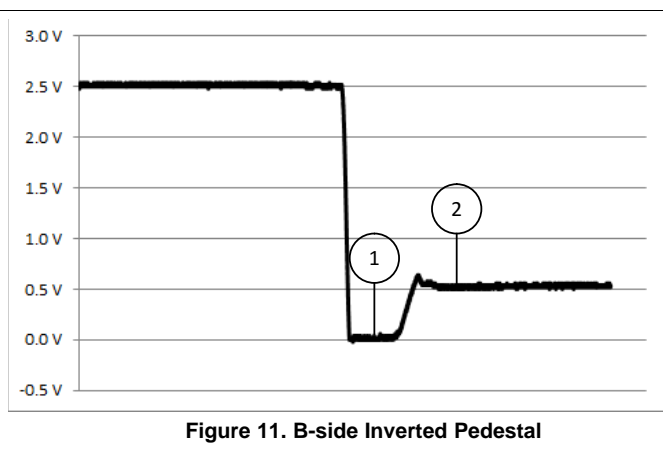
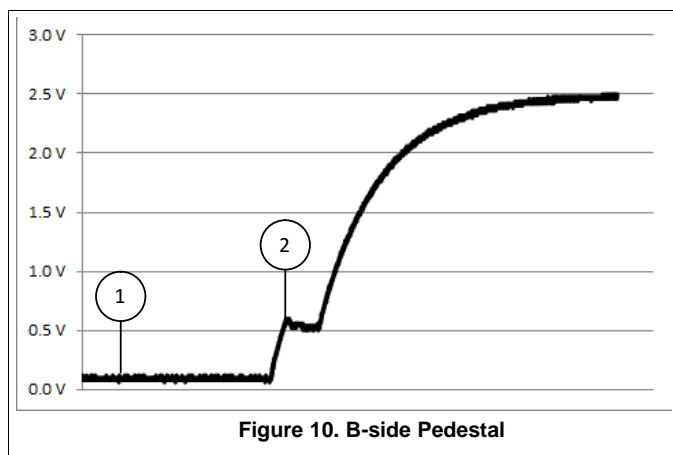

Typical Application (continued)

9.2.2 Star Application

Multiple TCA9617A A sides can be connected in a star configuration, allowing all nodes to communicate with each other.

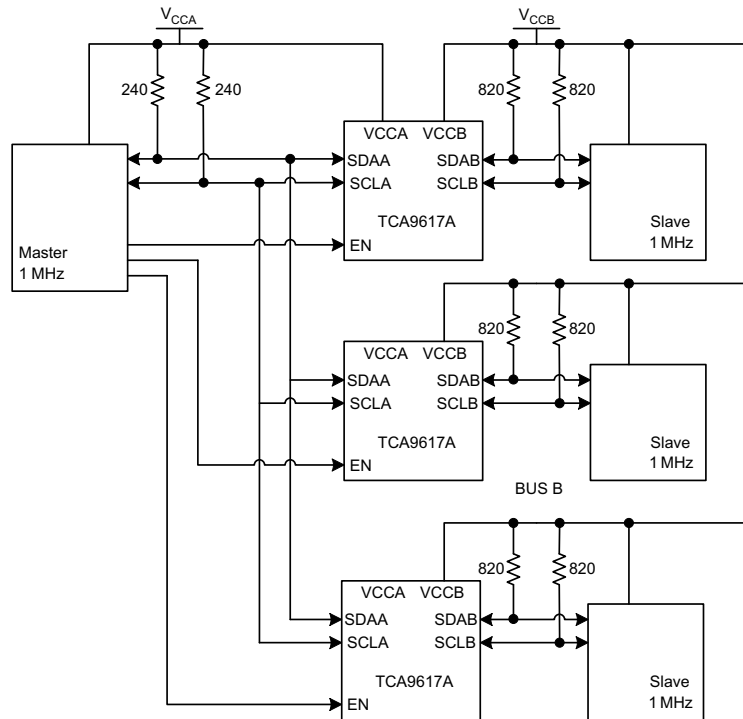

Figure 12. Typical Star Application

9.2.2.1 Design Requirements

Refer to [Design Requirements](#).

9.2.2.2 Detailed Design Procedure

Refer to [Detailed Design Procedure](#).

9.2.2.3 Application Curves

Refer to [Application Curves](#).

Typical Application (continued)

9.2.3 Series Application

Multiple TCA9617As can be connected in series as long as the A side is connected to the B side. I²C bus slave devices can be connected to any of the bus segments. The number of devices that can be connected in series is limited by repeater delay/time-of-flight considerations on the maximum bus speed requirements.

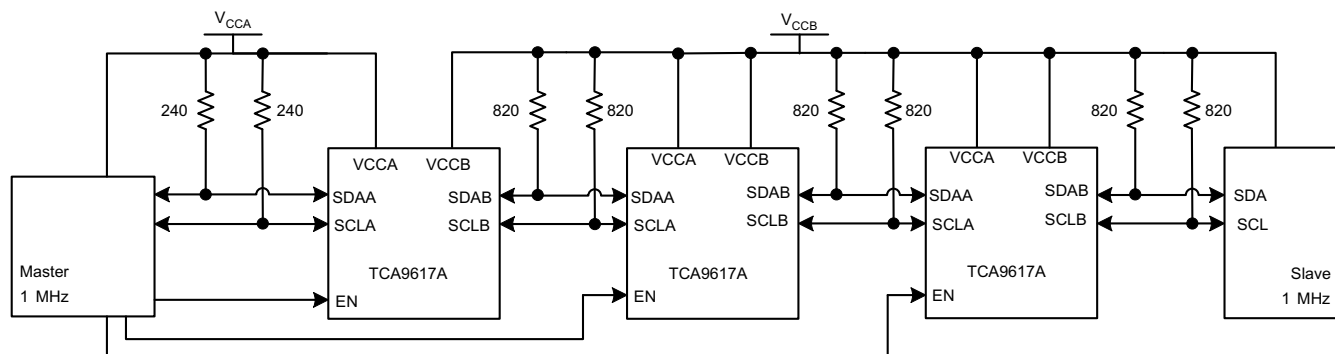

Figure 13. Typical Series Application

9.2.3.1 Design Requirements

Refer to [Design Requirements](#).

9.2.3.2 Detailed Design Procedure

Refer to [Detailed Design Procedure](#).

9.2.3.3 Application Curves

Refer to [Application Curves](#).

10 Power Supply Recommendations

For VCCA, an 0.8-V to 5.5-V power supply is required. For VCCB, a 2.2-V to 5.5-V power supply is required.

VCCB should always be higher than VCCA. VCCB cannot be lower than VCCA even when the device is disabled. During power-up, VCCB must rise before VCCA.

Standard decoupling capacitors are recommended. These capacitors typically range from 0.1 μ F to 1 μ F, but the ideal capacitance depends on the amount of noise from the power supply.

11 Layout

11.1 Layout Guidelines

The recommended decoupling capacitors should be placed as close to the V_{CCA} and V_{CCB} pins of the TCA9617A as possible.

11.2 Layout Example

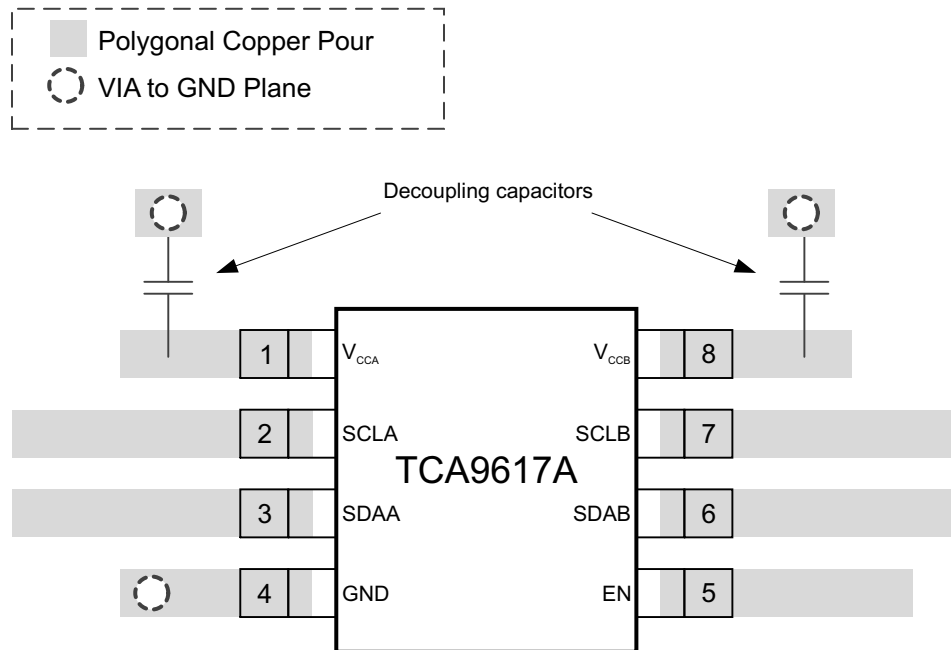

Figure 14. Layout Schematic

12 Device and Documentation Support

12.1 Receiving Notification of Documentation Updates

To receive notification of documentation updates, navigate to the device product folder on ti.com. In the upper right corner, click on *Alert me* to register and receive a weekly digest of any product information that has changed. For change details, review the revision history included in any revised document.

12.2 Community Resource

The following links connect to TI community resources. Linked contents are provided "AS IS" by the respective contributors. They do not constitute TI specifications and do not necessarily reflect TI's views; see TI's [Terms of Use](#).

TI E2E™ Online Community *TI's Engineer-to-Engineer (E2E) Community*. Created to foster collaboration among engineers. At e2e.ti.com, you can ask questions, share knowledge, explore ideas and help solve problems with fellow engineers.

Design Support *TI's Design Support* Quickly find helpful E2E forums along with design support tools and contact information for technical support.

12.3 Trademarks

E2E is a trademark of Texas Instruments.
All other trademarks are the property of their respective owners.

12.4 Electrostatic Discharge Caution



These devices have limited built-in ESD protection. The leads should be shorted together or the device placed in conductive foam during storage or handling to prevent electrostatic damage to the MOS gates.

12.5 Glossary

[SLYZ022](#) — *TI Glossary*.

This glossary lists and explains terms, acronyms, and definitions.

13 Mechanical, Packaging, and Orderable Information

The following pages include mechanical, packaging, and orderable information. This information is the most current data available for the designated devices. This data is subject to change without notice and revision of this document. For browser-based versions of this data sheet, refer to the left-hand navigation.

PACKAGING INFORMATION

Orderable Device	Status (1)	Package Type	Package Drawing	Pins	Package Qty	Eco Plan (2)	Lead/Ball Finish (6)	MSL Peak Temp (3)	Op Temp (°C)	Device Marking (4/5)	Samples
TCA9617ADGKR	ACTIVE	VSSOP	DGK	8	2500	Green (RoHS & no Sb/Br)	CU NIPDAUAG	Level-1-260C-UNLIM	-40 to 85	(7EA, DWK)	Samples

(1) The marketing status values are defined as follows:

ACTIVE: Product device recommended for new designs.

LIFEBUY: TI has announced that the device will be discontinued, and a lifetime-buy period is in effect.

NRND: Not recommended for new designs. Device is in production to support existing customers, but TI does not recommend using this part in a new design.

PREVIEW: Device has been announced but is not in production. Samples may or may not be available.

OBSOLETE: TI has discontinued the production of the device.

(2) **RoHS:** TI defines "RoHS" to mean semiconductor products that are compliant with the current EU RoHS requirements for all 10 RoHS substances, including the requirement that RoHS substance do not exceed 0.1% by weight in homogeneous materials. Where designed to be soldered at high temperatures, "RoHS" products are suitable for use in specified lead-free processes. TI may reference these types of products as "Pb-Free".

RoHS Exempt: TI defines "RoHS Exempt" to mean products that contain lead but are compliant with EU RoHS pursuant to a specific EU RoHS exemption.

Green: TI defines "Green" to mean the content of Chlorine (Cl) and Bromine (Br) based flame retardants meet JS709B low halogen requirements of <=1000ppm threshold. Antimony trioxide based flame retardants must also meet the <=1000ppm threshold requirement.

(3) MSL, Peak Temp. - The Moisture Sensitivity Level rating according to the JEDEC industry standard classifications, and peak solder temperature.

(4) There may be additional marking, which relates to the logo, the lot trace code information, or the environmental category on the device.

(5) Multiple Device Markings will be inside parentheses. Only one Device Marking contained in parentheses and separated by a "~" will appear on a device. If a line is indented then it is a continuation of the previous line and the two combined represent the entire Device Marking for that device.

(6) Lead/Ball Finish - Orderable Devices may have multiple material finish options. Finish options are separated by a vertical ruled line. Lead/Ball Finish values may wrap to two lines if the finish value exceeds the maximum column width.

Important Information and Disclaimer:The information provided on this page represents TI's knowledge and belief as of the date that it is provided. TI bases its knowledge and belief on information provided by third parties, and makes no representation or warranty as to the accuracy of such information. Efforts are underway to better integrate information from third parties. TI has taken and continues to take reasonable steps to provide representative and accurate information but may not have conducted destructive testing or chemical analysis on incoming materials and chemicals. TI and TI suppliers consider certain information to be proprietary, and thus CAS numbers and other limited information may not be available for release.

In no event shall TI's liability arising out of such information exceed the total purchase price of the TI part(s) at issue in this document sold by TI to Customer on an annual basis.

TAPE AND REEL INFORMATION



QUADRANT ASSIGNMENTS FOR PIN 1 ORIENTATION IN TAPE



*All dimensions are nominal

Device	Package Type	Package Drawing	Pins	SPQ	Reel Diameter (mm)	Reel Width W1 (mm)	A0 (mm)	B0 (mm)	K0 (mm)	P1 (mm)	W (mm)	Pin1 Quadrant
TCA9617ADGKR	VSSOP	DGK	8	2500	330.0	12.4	5.3	3.4	1.4	8.0	12.0	Q1

TAPE AND REEL BOX DIMENSIONS

*All dimensions are nominal

Device	Package Type	Package Drawing	Pins	SPQ	Length (mm)	Width (mm)	Height (mm)
TCA9617ADGKR	VSSOP	DGK	8	2500	364.0	364.0	27.0

DGK (S-PDSO-G8)

PLASTIC SMALL-OUTLINE PACKAGE

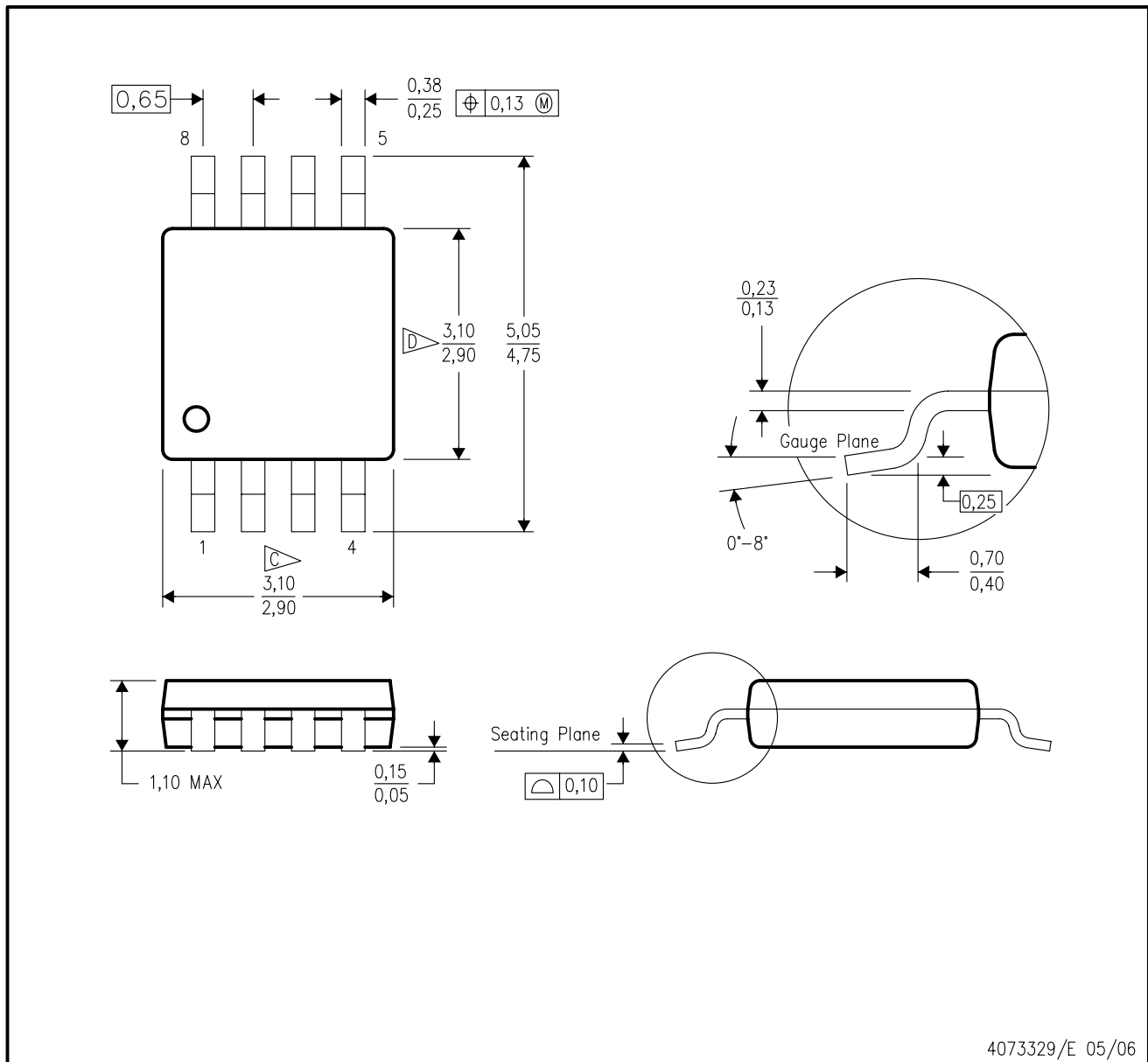

4073329/E 05/06

- NOTES:
- A. All linear dimensions are in millimeters.
 - B. This drawing is subject to change without notice.
 - C. Body length does not include mold flash, protrusions, or gate burrs. Mold flash, protrusions, or gate burrs shall not exceed 0.15 per end.
 - D. Body width does not include interlead flash. Interlead flash shall not exceed 0.50 per side.
 - E. Falls within JEDEC MO-187 variation AA, except interlead flash.

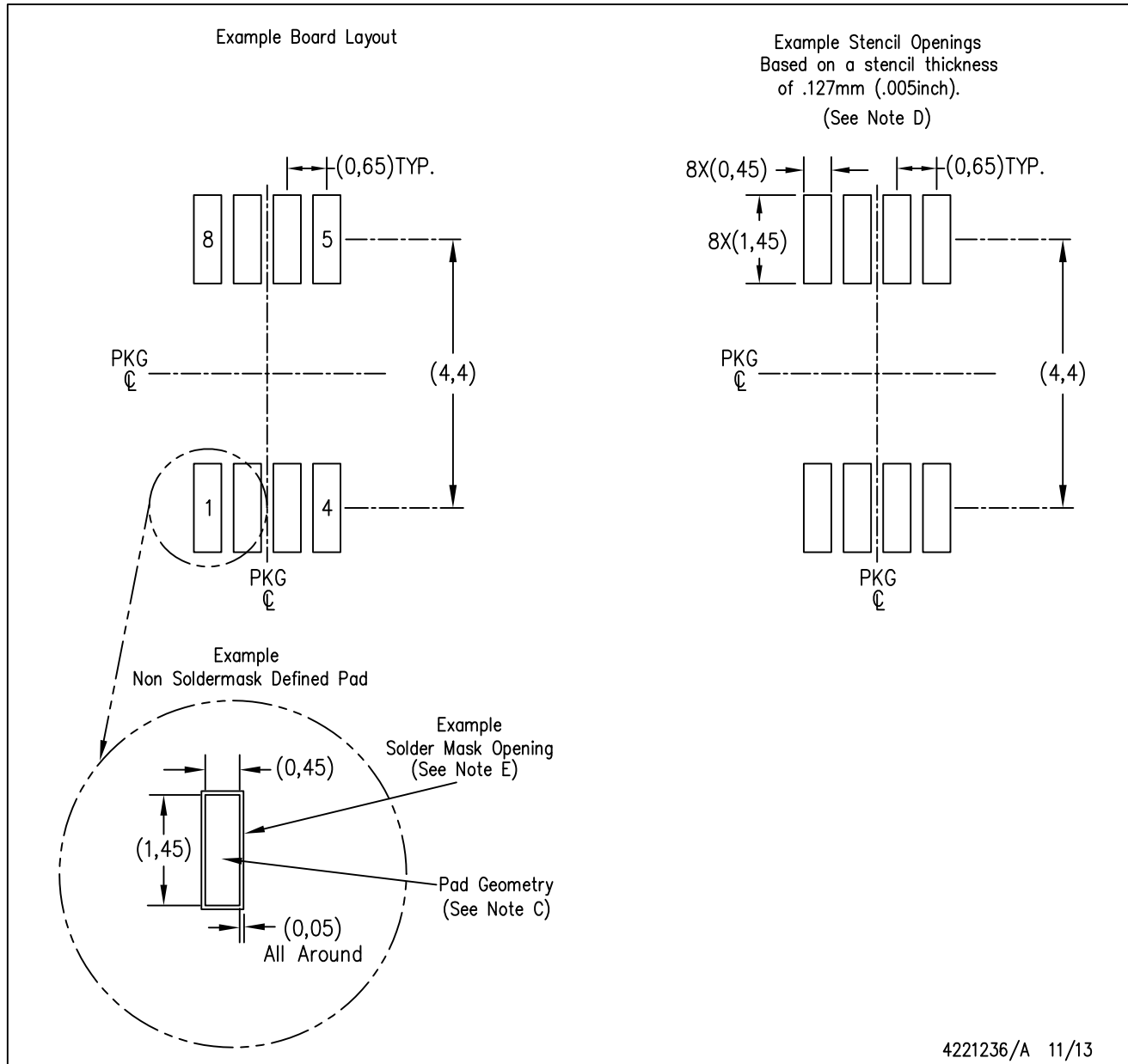

- NOTES:
- A. All linear dimensions are in millimeters.
 - B. This drawing is subject to change without notice.
 - C. Publication IPC-7351 is recommended for alternate designs.
 - D. Laser cutting apertures with trapezoidal walls and also rounding corners will offer better paste release. Customers should contact their board assembly site for stencil design recommendations. Refer to IPC-7525 for other stencil recommendations.
 - E. Customers should contact their board fabrication site for solder mask tolerances between and around signal pads.

IMPORTANT NOTICE AND DISCLAIMER

TI PROVIDES TECHNICAL AND RELIABILITY DATA (INCLUDING DATASHEETS), DESIGN RESOURCES (INCLUDING REFERENCE DESIGNS), APPLICATION OR OTHER DESIGN ADVICE, WEB TOOLS, SAFETY INFORMATION, AND OTHER RESOURCES "AS IS" AND WITH ALL FAULTS, AND DISCLAIMS ALL WARRANTIES, EXPRESS AND IMPLIED, INCLUDING WITHOUT LIMITATION ANY IMPLIED WARRANTIES OF MERCHANTABILITY, FITNESS FOR A PARTICULAR PURPOSE OR NON-INFRINGEMENT OF THIRD PARTY INTELLECTUAL PROPERTY RIGHTS.

These resources are intended for skilled developers designing with TI products. You are solely responsible for (1) selecting the appropriate TI products for your application, (2) designing, validating and testing your application, and (3) ensuring your application meets applicable standards, and any other safety, security, or other requirements. These resources are subject to change without notice. TI grants you permission to use these resources only for development of an application that uses the TI products described in the resource. Other reproduction and display of these resources is prohibited. No license is granted to any other TI intellectual property right or to any third party intellectual property right. TI disclaims responsibility for, and you will fully indemnify TI and its representatives against, any claims, damages, costs, losses, and liabilities arising out of your use of these resources.

TI's products are provided subject to TI's Terms of Sale (www.ti.com/legal/termsofsale.html) or other applicable terms available either on ti.com or provided in conjunction with such TI products. TI's provision of these resources does not expand or otherwise alter TI's applicable warranties or warranty disclaimers for TI products.

Mailing Address: Texas Instruments, Post Office Box 655303, Dallas, Texas 75265
Copyright © 2018, Texas Instruments Incorporated

Looking for pricing, stock, or lifecycle information?

Click below to explore more details on WIN SOURCE:

 [View TCA9617ADGKR on WIN SOURCE](#)

 [Texas Instruments](#) Information

Optimize Your Supply Chain with WIN SOURCE Solutions

-  Global Sourcing Solution
-  Obsolete Management
-  Cost Control Management
-  Shortage Management
-  Alternative Solution
-  Excess Inventory Management