



**THE DATASHEET OF  
TCA6416ARTWR**



# TCA6416A Low-Voltage 16-Bit I<sup>2</sup>C and SMBus I/O Expander With Voltage Translation, Interrupt Output, Reset Input, and Configuration Registers

## 1 Features

- I<sup>2</sup>C to parallel port expander
- Operating power-supply voltage range of 1.65 V to 5.5 V
- Allows bidirectional voltage-level translation and GPIO expansion between 1.8-V, 2.5-V, 3.3-V, and 5-V I<sup>2</sup>C Bus and P-ports
- Low standby current consumption of 3  $\mu$ A
- 5-V Tolerant I/O ports
- 400-kHz Fast I<sup>2</sup>C bus
- Hardware address pin allows two TCA6416A devices on the same I<sup>2</sup>C/SMBus bus
- Active-low reset input ( $\overline{\text{RESET}}$ )
- Open-drain active-low interrupt output ( $\overline{\text{INT}}$ )
- Input/output configuration register
- Polarity inversion register
- Internal power-on reset
- Power-up with all channels configured as inputs
- No glitch on power up
- Noise filter on SCL and SDA inputs
- Latched outputs with high-current drive maximum capability for directly driving LEDs
- Latch-up performance exceeds 100 mA Per JESD 78, class II
- ESD Protection exceeds JESD 22
  - 2000-V Human-body model (A114-A)
  - 200-V Machine model (A115-A)
  - 1000-V Charged-device model (C101)

## 2 Applications

- Servers
- Routers (telecom switching equipment)
- [Personal computers](#)
- [Personal electronics](#) (for example, gaming consoles)
- [Industrial automation](#)
- Products with GPIO-limited processors

## 3 Description

The TCA6416A is a 24-pin device that provides 16-bits of general purpose parallel input/output (I/O) expansion for the two-line bidirectional I<sup>2</sup>C bus (or SMBus) protocol. The device can operate with a power supply voltage ranging from 1.65 V to 5.5 V on the I<sup>2</sup>C bus side (VCCI) and a power supply voltage ranging from 1.65 V to 5.5 V on the P-port side (VCCP).

The device supports both 100-kHz (Standard-mode) and 400-kHz (Fast-mode) clock frequencies. I/O expanders such as the TCA6416A provide a simple solution when additional I/Os are needed for switches, sensors, push-buttons, LEDs, fans, and so forth.

### Package Information

PART NUMBER	PACKAGE <sup>(1)</sup>	BODY SIZE (NOM)
TCA6416A	TSSOP (24)	7.80 mm × 4.40 mm
	WQFN (24)	4.00 mm × 4.00 mm
	Microstar BGA™ Junior (24)	3.00 mm × 3.00 mm

(1) For all available packages, see the orderable addendum at the end of the datasheet.

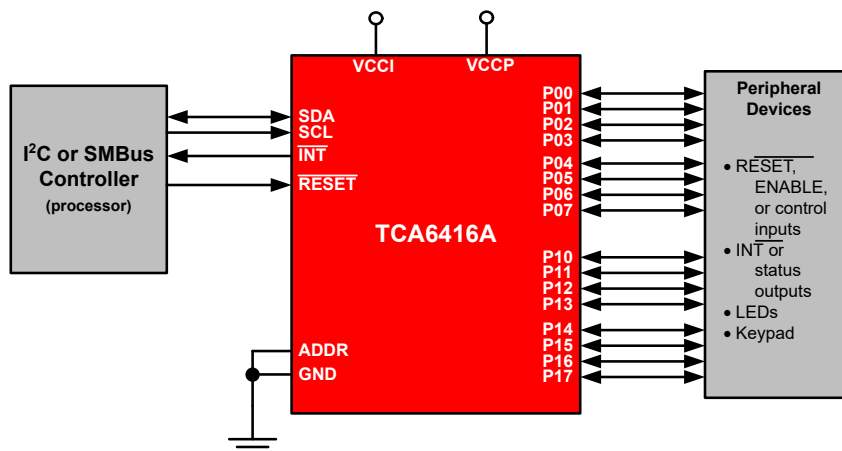

Simplified Schematic



## Table of Contents

<b>1 Features</b> .....	1	8.4 Device Functional Modes.....	20
<b>2 Applications</b> .....	1	8.5 Programming.....	20
<b>3 Description</b> .....	1	8.6 Register Maps.....	21
<b>4 Revision History</b> .....	2	<b>9 Application and Implementation</b> .....	26
<b>5 Pin Configuration and Functions</b> .....	3	9.1 Application Information.....	26
<b>6 Specifications</b> .....	5	9.2 Typical Application.....	26
6.1 Absolute Maximum Ratings.....	5	<b>10 Power Supply Recommendations</b> .....	29
6.2 ESD Ratings.....	5	10.1 Power-On Reset Requirements.....	29
6.3 Recommended Operating Conditions.....	6	<b>11 Layout</b> .....	31
6.4 Thermal Information.....	6	11.1 Layout Guidelines.....	31
6.5 Electrical Characteristics.....	7	11.2 Layout Example.....	32
6.6 I <sup>2</sup> C Interface Timing Requirements.....	9	<b>12 Device and Documentation Support</b> .....	33
6.7 Reset Timing Requirements.....	9	12.1 Receiving Notification of Documentation Updates..	33
6.8 Switching Characteristics.....	9	12.2 Support Resources.....	33
6.9 Typical Characteristics.....	10	12.3 Trademarks.....	33
<b>7 Parameter Measurement Information</b> .....	13	12.4 Electrostatic Discharge Caution.....	33
<b>8 Detailed Description</b> .....	17	12.5 Glossary.....	33
8.1 Overview.....	17	<b>13 Mechanical, Packaging, and Orderable Information</b> .....	33
8.2 Functional Block Diagrams.....	18		
8.3 Feature Description.....	18		

## 4 Revision History

NOTE: Page numbers for previous revisions may differ from page numbers in the current version.

Changes from Revision E (July 2020) to Revision F (January 2023)	Page
• Changed all instances of legacy terminology to controller and target where I <sup>2</sup> C is mentioned.....	1
• Changed the Pin Configuration and Functions section.....	3
• Added paragraph: "Ramping up the device V <sub>CCP</sub> " to <i>Power-On Reset Requirements</i> .....	29
Changes from Revision D (August 2017) to Revision E (July 2020)	Page
• Added T <sub>J</sub> Max junction temperature to the <i>Absolute Maximum Ratings</i> table.....	5
• Added new values for T <sub>A</sub> > 85 °C in the <i>Recommended Operation Conditions</i> table.....	6
• Added new values for T <sub>A</sub> > 85 °C in the <i>Electrical Characteristics</i> table.....	7
• Changed RESET ΔI <sub>CCI</sub> <i>Electrical Characteristics</i> table.....	7
Changes from Revision C (September 2015) to Revision D (August 2017)	Page
• Changed the t <sub>vd(data)</sub> MAX value From: 1 μs To: 0.9 μs in the <i>I<sup>2</sup>C Interface Timing Requirements</i> table.....	9
• Changed the t <sub>vd(ack)</sub> MAX value From: 1 μs To: 0.9 μs in the <i>I<sup>2</sup>C Interface Timing Requirements</i> table.....	9
Changes from Revision B (January 2015) to Revision C (September 2015)	Page
• Changed units for t <sub>IV</sub> and t <sub>IR</sub> parameters from ns to μs.....	9
Changes from Revision A (November 2009) to Revision B (October 2014)	Page
• Added <i>ESD Ratings</i> table, <i>Feature Description</i> section, <i>Device Functional Modes</i> , <i>Application and Implementation</i> section, <i>Power Supply Recommendations</i> section, <i>Layout</i> section, <i>Device and Documentation Support</i> section, and <i>Mechanical, Packaging, and Orderable Information</i> section. ....	1

## 5 Pin Configuration and Functions

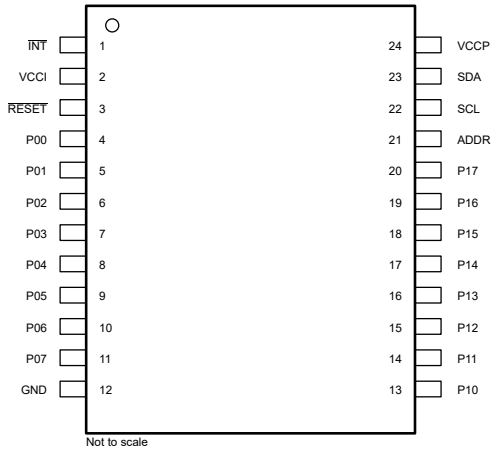

**Figure 5-1. PW package, 24-Pin TSSOP (Top View)**

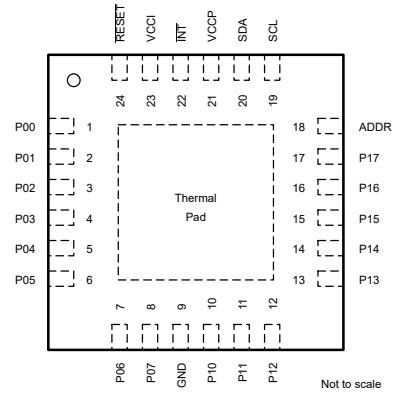

**Figure 5-2. RTW Package, 24-Pin WQFN (Top View)**

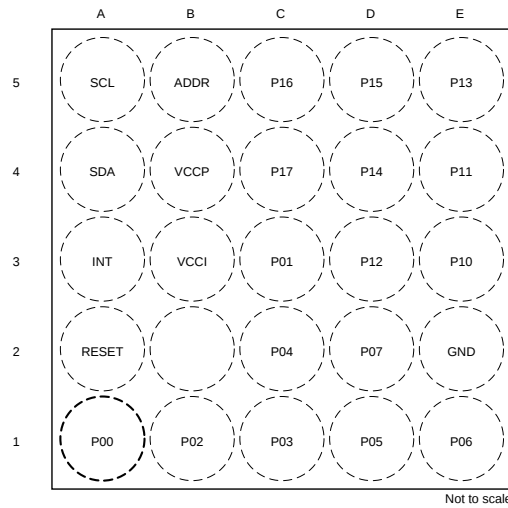

**Figure 5-3. ZQS Package 24-Pin Microstar BGA™ Junior (Top View)**

Table 5-1. Pin Functions

PIN				DESCRIPTION
NAME	TSSOP (PW)	QFN (RTW)	BGA (ZQS)	
INT	1	22	A3	Interrupt output. Connect to $V_{CCI}$ or $V_{CCP}$ through a pull-up resistor.
VCCI	2	23	B3	Supply voltage of I <sup>2</sup> C bus. Connect directly to the supply voltage of the external I <sup>2</sup> C controller.
RESET	3	24	A2	Active-low reset input. Connect to $V_{CCI}$ or $V_{CCP}$ through a pull-up resistor, if no active connection is used.
P00	4	1	A1	P-port input/output (push-pull design structure). At power on, P00 is configured as an input.
P01	5	2	C3	P-port input/output (push-pull design structure). At power on, P01 is configured as an input.
P02	6	3	B1	P-port input/output (push-pull design structure). At power on, P02 is configured as an input.
P03	7	4	C1	P-port input/output (push-pull design structure). At power on, P03 is configured as an input.
P04	8	5	C2	P-port input/output (push-pull design structure). At power on, P04 is configured as an input.
P05	9	6	D1	P-port input/output (push-pull design structure). At power on, P05 is configured as an input.
P06	10	7	E1	P-port input/output (push-pull design structure). At power on, P06 is configured as an input.
P07	11	8	D2	P-port input/output (push-pull design structure). At power on, P07 is configured as an input.
GND	12	9	E2	Ground
P10	13	10	E3	P-port input/output (push-pull design structure). At power on, P10 is configured as an input.
P11	14	11	E4	P-port input/output (push-pull design structure). At power on, P11 is configured as an input.
P12	15	12	D3	P-port input/output (push-pull design structure). At power on, P12 is configured as an input.
P13	16	13	E5	P-port input/output (push-pull design structure). At power on, P13 is configured as an input.
P14	17	14	D4	P-port input/output (push-pull design structure). At power on, P14 is configured as an input.
P15	18	15	D5	P-port input/output (push-pull design structure). At power on, P15 is configured as an input.
P16	19	16	C5	P-port input/output (push-pull design structure). At power on, P16 is configured as an input.
P17	20	17	C4	P-port input/output (push-pull design structure). At power on, P17 is configured as an input.
ADDR	21	18	B5	Address input. Connect directly to $V_{CCP}$ or ground.
SCL	22	19	A5	Serial clock bus. Connect to $V_{CCI}$ through a pull-up resistor.
SDA	23	20	A4	Serial data bus. Connect to $V_{CCI}$ through a pull-up resistor.
VCCP	24	21	B4	Supply voltage of TCA6416A for P-ports

## 6 Specifications

### 6.1 Absolute Maximum Ratings

over operating free-air temperature range (unless otherwise noted) <sup>(1)</sup>

				MIN	MAX	UNIT
V <sub>CCI</sub>	Supply voltage			-0.5	6.5	V
V <sub>CCP</sub>	Supply voltage			-0.5	6.5	V
V <sub>I</sub>	Input voltage <sup>(2)</sup>			-0.5	6.5	V
V <sub>O</sub>	Output voltage <sup>(2)</sup>			-0.5	6.5	V
I <sub>IK</sub>	Input clamp current	ADDR, RESET, SCL	V <sub>I</sub> < 0		±20	mA
I <sub>OK</sub>	Output clamp current	INT	V <sub>O</sub> < 0		±20	mA
I <sub>IOK</sub>	Input/output clamp current	P port	V <sub>O</sub> < 0 or V <sub>O</sub> > V <sub>CCP</sub>		±20	mA
		SDA	V <sub>O</sub> < 0 or V <sub>O</sub> > V <sub>CCI</sub>		±20	
I <sub>OL</sub>	Continuous output low current	P port	V <sub>O</sub> = 0 to V <sub>CCP</sub>		50	mA
		SDA, INT	V <sub>O</sub> = 0 to V <sub>CCI</sub>		25	
I <sub>OH</sub>	Continuous output high current	P port	V <sub>O</sub> = 0 to V <sub>CCP</sub>		50	mA
I <sub>CC</sub>	Continuous current through GND				200	mA
	Continuous current through V <sub>CCP</sub>				160	
	Continuous current through V <sub>CCI</sub>				10	
T <sub>J</sub>	Max junction temperature	V <sub>CC</sub> ≤ 3.6 V			130	°C
		3.6 V < V <sub>CC</sub> ≤ 5.5 V			90	
T <sub>stg</sub>	Storage temperature			-65	150	°C

- (1) Stresses beyond those listed under *Absolute Maximum Ratings* may cause permanent damage to the device. These are stress ratings only, and functional operation of the device at these or any other conditions beyond those indicated under *Recommended Operating Conditions* is not implied. Exposure to absolute-maximum-rated conditions for extended periods may affect device reliability.
- (2) The input negative-voltage and output voltage ratings may be exceeded if the input and output current ratings are observed.

### 6.2 ESD Ratings

			VALUE	UNIT
V <sub>(ESD)</sub>	Electrostatic discharge	Human-body model (HBM), per ANSI/ESDA/JEDEC JS-001 <sup>(1)</sup>	±2000	V
		Charged-device model (CDM), per JEDEC specification JESD22-C101 <sup>(2)</sup>	±1000	

- (1) JEDEC document JEP155 states that 500-V HBM allows safe manufacturing with a standard ESD control process.
- (2) JEDEC document JEP157 states that 250-V CDM allows safe manufacturing with a standard ESD control process.

### 6.3 Recommended Operating Conditions

			MIN	MAX	UNIT	
V <sub>CCI</sub>	Supply voltage	-40 °C ≤ T <sub>A</sub> ≤ 85 °C	1.65	5.5	V	
		85 °C < T <sub>A</sub> ≤ 125 °C	1.65	3.6		
V <sub>CCP</sub>	Supply voltage	-40 °C ≤ T <sub>A</sub> ≤ 85 °C	1.65	5.5	V	
		85 °C < T <sub>A</sub> ≤ 125 °C	1.65	3.6		
V <sub>IH</sub>	High-level input voltage	SCL, SDA	0.7 × V <sub>CCI</sub>	V <sub>CCI</sub> <sup>(1)</sup>	V	
		RESET	0.7 × V <sub>CCI</sub>	5.5		
		ADDR, P17–P00	0.7 × V <sub>CCP</sub>	5.5		
V <sub>IL</sub>	Low-level input voltage	SCL, SDA, RESET	-0.5	0.3 × V <sub>CCI</sub>	V	
		ADDR, P17–P00	-0.5	0.3 × V <sub>CCP</sub>		
I <sub>OH</sub>	High-level output current	P17–P00		10	mA	
I <sub>OL</sub>	Low-level output current	P17–P00	T <sub>J</sub> ≤ 65 °C		25	mA
			T <sub>J</sub> ≤ 85 °C		18	
			T <sub>J</sub> ≤ 105 °C		9	
			T <sub>J</sub> ≤ 125 °C		4.5	
			T <sub>J</sub> ≤ 135 °C		3.5	
T <sub>A</sub>	Operating free-air temperature	1.65 V ≤ V <sub>CC</sub> ≤ 3.6 V	-40	125	°C	
		3.6 V < V <sub>CC</sub> ≤ 5.5 V	-40	85		

- (1) The SCL and SDA pins shall not be at a higher potential than the supply voltage V<sub>CCI</sub> in the application, or an increase in current consumption will result.

### 6.4 Thermal Information

THERMAL METRIC <sup>(1)</sup>	TCA6416A			UNIT	
	PW (TSSOP)	RTW (WQFN)	ZQS (BGA MICROSTAR JUNIOR)		
	24 PINS	24 PINS	24 PINS		
R <sub>θJA</sub>	Junction-to-ambient thermal resistance	108.8	43.6	159.2	°C/W
R <sub>θJC(top)</sub>	Junction-to-case (top) thermal resistance	54.0	46.2	138.2	°C/W
R <sub>θJB</sub>	Junction-to-board thermal resistance	62.8	22.1	93.6	°C/W
ψ <sub>JT</sub>	Junction-to-top characterization parameter	11.1	1.5	10.7	°C/W
ψ <sub>JB</sub>	Junction-to-board characterization parameter	62.3	22.2	95.7	°C/W
R <sub>θJC(bot)</sub>	Junction-to-case (bottom) thermal resistance	N/A	10.7	N/A	°C/W

- (1) For more information about traditional and new thermal metrics, see the [Semiconductor and IC Package Thermal Metrics](#) application report.

## 6.5 Electrical Characteristics

over recommended operating free-air temperature range,  $V_{CCI} = 1.65\text{ V to }5.5\text{ V}$  (unless otherwise noted)

PARAMETER		TEST CONDITIONS		$V_{CCP}$	MIN	TYP <sup>(1)</sup>	MAX	UNIT	
$V_{IK}$	Input diode clamp voltage	$I_I = -18\text{ mA}$		1.65 V to 5.5 V	-1.2			V	
$V_{POR}$	Power-on reset voltage	$V_I = V_{CCP}$ or GND, $I_O = 0$		1.65 V to 5.5 V		1	1.4	V	
$V_{OH}$	P-port high-level output voltage	$I_{OH} = -8\text{ mA}$		1.65 V	1.2			V	
				2.3 V	1.8				
				3 V	2.6				
				4.5 V	4.1				
		$I_{OH} = -10\text{ mA}$	$85\text{ °C} < T_A \leq 125\text{ °C}$	1.65 V	1.0				
				$-40\text{ °C} \leq T_A \leq 85\text{ °C}$	1.1				
				$-40\text{ °C} \leq T_A \leq 125\text{ °C}$	2.3 V	1.7			
				$-40\text{ °C} \leq T_A \leq 85\text{ °C}$	3 V	2.5			
$V_{OL}$	P-port low-level output voltage	$I_{OL} = 8\text{ mA}$	$-40\text{ °C} \leq T_A \leq 125\text{ °C}$	1.65 V			0.45	V	
				2.3 V			0.25		
				3 V			0.25		
				4.5 V			0.2		
		$I_{OL} = 10\text{ mA}$	$-40\text{ °C} \leq T_A \leq 125\text{ °C}$	1.65 V			0.6		
				2.3 V			0.3		
				3 V			0.25		
				4.5 V			0.2		
$I_{OL}$	SDA	$V_{OL} = 0.4\text{ V}$		1.65 V to 5.5 V	3			mA	
	INT	$V_{OL} = 0.4\text{ V}$		1.65 V to 5.5 V	3	15			
$I_I$	SCL, SDA, RESET	$V_I = V_{CCI}$ or GND		1.65 V to 5.5 V			$\pm 0.1$	$\mu\text{A}$	
	ADDR	$V_I = V_{CCP}$ or GND					$\pm 0.1$		
$I_{IH}$	P port	$V_I = V_{CCP}$		1.65 V to 5.5 V			1	$\mu\text{A}$	
$I_{IL}$	P port	$V_I = \text{GND}$					1	$\mu\text{A}$	
$I_{CC}$ ( $I_{CCI} + I_{CCP}$ )	Operating mode	$V_I$ on SDA and RESET = $V_{CCI}$ or GND, $V_I$ on P port and ADDR = $V_{CCP}$ , $I_O = 0$ , I/O = inputs, $f_{SCL} = 400\text{ kHz}$	$-40\text{ °C} \leq T_A \leq 85\text{ °C}$	3.6 V to 5.5 V	10	20	$\mu\text{A}$		
				2.3 V to 3.6 V	6.5	15			
			$85\text{ °C} < T_A \leq 125\text{ °C}$	1.65 V to 2.3 V	4	9			
				2.3 V to 3.6 V		40			
	Standby mode	$V_I$ on SCL, SDA and RESET = $V_{CCI}$ or GND, $V_I$ on P port and ADDR = $V_{CCP}$ , $I_O = 0$ , I/O = inputs, $f_{SCL} = 0$	$-40\text{ °C} \leq T_A \leq 85\text{ °C}$	3.6 V to 5.5 V	1.5	7			
				2.3 V to 3.6 V	1	3.2			
			$85\text{ °C} < T_A \leq 125\text{ °C}$	1.65 V to 2.3 V	0.5	1.7			
				2.3 V to 3.6 V		10			
$\Delta I_{CCI}$	SCL, SDA, ADDR	Input at $V_{CCI} - 0.6\text{ V}$ , Other inputs at $V_{CCI}$ or GND		1.65 V to 5.5 V			25	$\mu\text{A}$	
	RESET	RESET at $V_{CCI} - 0.6\text{ V}$ , Other inputs at $V_{CCI}$ or GND					55		
$\Delta I_{CCP}$	P port	One input at $V_{CCP} - 0.6\text{ V}$ , Other inputs at $V_{CCP}$ or GND					80		
$C_i$	SCL	$V_I = V_{CCI}$ or GND		1.65 V to 5.5 V		6	7	pF	

## 6.5 Electrical Characteristics (continued)

over recommended operating free-air temperature range,  $V_{CCI} = 1.65\text{ V to }5.5\text{ V}$  (unless otherwise noted)

PARAMETER		TEST CONDITIONS	$V_{CCP}$	MIN	TYP <sup>(1)</sup>	MAX	UNIT
$C_{io}$	SDA	$V_{IO} = V_{CCI}$ or GND	1.65 V to 5.5 V		7	8	pF
	P port	$V_{IO} = V_{CCP}$ or GND			7.5	8.5	

- (1) Except for  $I_{CC}$ , all typical values are at nominal supply voltage (1.8-V, 2.5-V, 3.3-V, or 5-V  $V_{CC}$ ) and  $T_A = 25^\circ\text{C}$ . For  $I_{CC}$ , the typical values are at  $V_{CCP} = V_{CCI} = 3.3\text{ V}$  and  $T_A = 25^\circ\text{C}$ .

## 6.6 I<sup>2</sup>C Interface Timing Requirements

over recommended operating free-air temperature range (unless otherwise noted) (see [Figure 7-1](#))

		STANDARD MODE I <sup>2</sup> C BUS		FAST MODE I <sup>2</sup> C BUS		UNIT
		MIN	MAX	MIN	MAX	
f <sub>scl</sub>	I <sup>2</sup> C clock frequency	0	100	0	400	kHz
t <sub>sch</sub>	I <sup>2</sup> C clock high time	4		0.6		μs
t <sub>scl</sub>	I <sup>2</sup> C clock low time	4.7		1.3		μs
t <sub>sp</sub>	I <sup>2</sup> C spike time	0	50	0	50	ns
t <sub>sds</sub>	I <sup>2</sup> C serial data setup time	250		100		ns
t <sub>sdh</sub>	I <sup>2</sup> C serial data hold time	0		0		ns
t <sub>icr</sub>	I <sup>2</sup> C input rise time		1000	20 + 0.1C <sub>b</sub> <sup>(1)</sup>	300	ns
t <sub>icf</sub>	I <sup>2</sup> C input fall time		300	20 + 0.1C <sub>b</sub> <sup>(1)</sup>	300	ns
t <sub>ocf</sub>	I <sup>2</sup> C output fall time; 10 pF to 400 pF bus		300	20 + 0.1C <sub>b</sub> <sup>(1)</sup>	300	μs
t <sub>buf</sub>	I <sup>2</sup> C bus free time between Stop and Start	4.7		1.3		μs
t <sub>sts</sub>	I <sup>2</sup> C Start or repeater Start condition setup time	4.7		0.6		μs
t <sub>sth</sub>	I <sup>2</sup> C Start or repeater Start condition hold time	4		0.6		μs
t <sub>sps</sub>	I <sup>2</sup> C Stop condition setup time	4		0.6		μs
t <sub>vd(data)</sub>	Valid data time; SCL low to SDA output valid		1		0.9	μs
t <sub>vd(ack)</sub>	Valid data time of ACK condition; ACK signal from SCL low to SDA (out) low		1		0.9	μs

(1) C<sub>b</sub> = total capacitance of one bus line in pF

## 6.7 Reset Timing Requirements

over recommended operating free-air temperature range (unless otherwise noted) (see [Figure 7-4](#))

		STANDARD MODE I <sup>2</sup> C BUS		FAST MODE I <sup>2</sup> C BUS		UNIT
		MIN	MAX	MIN	MAX	
t <sub>W</sub>	Reset pulse duration	4		4		ns
t <sub>REC</sub>	Reset recovery time	0		0		ns
t <sub>RESET</sub>	Time to reset <sup>(1)</sup>	600		600		ns

(1) Minimum time for SDA to become high or minimum time to wait before doing a START

## 6.8 Switching Characteristics

over recommended operating free-air temperature range, C<sub>L</sub> ≤ 100 pF (unless otherwise noted) (see [Figure 7-1](#))

PARAMETER	FROM	TO	STANDARD MODE I <sup>2</sup> C BUS		FAST MODE I <sup>2</sup> C BUS		UNIT
			MIN	MAX	MIN	MAX	
t <sub>IV</sub>	Interrupt valid time	P port		4		4	μs
t <sub>IR</sub>	Interrupt reset delay time	SCL		4		4	μs
t <sub>PV</sub>	Output data valid	SCL		400		400	ns
t <sub>PS</sub>	Input data setup time	P port	0		0		ns
t <sub>PH</sub>	Input data hold time	P port	300		300		ns

## 6.9 Typical Characteristics

$T_A = 25^\circ\text{C}$  (unless otherwise noted)

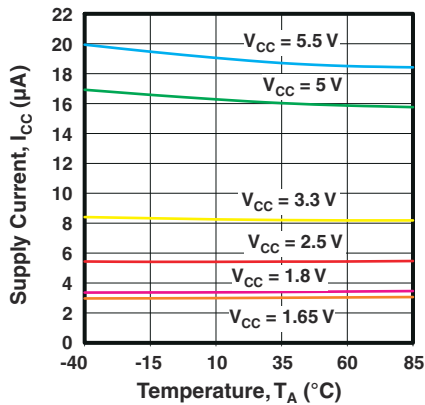

Figure 6-1. Supply Current vs Temperature

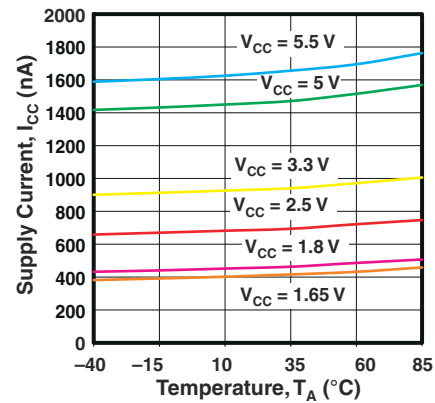

Figure 6-2. Standby Supply Current vs Temperature

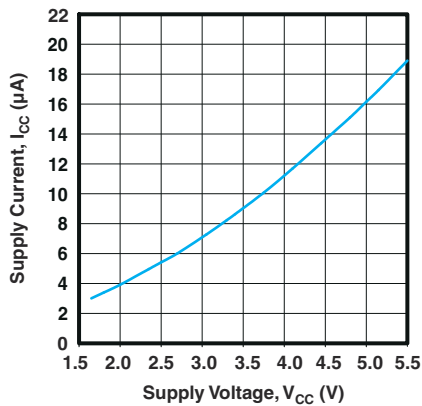

Figure 6-3. Supply Current vs Supply Voltage

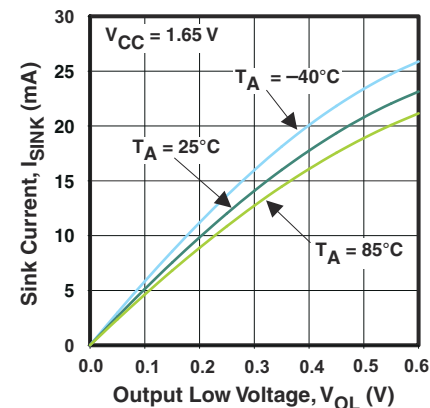

Figure 6-4. I/O Sink Current vs Output Low Voltage

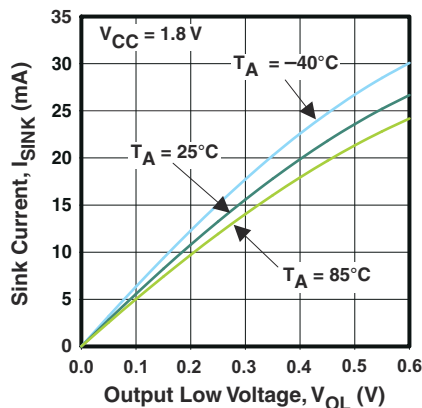

Figure 6-5. I/O Sink Current vs Output Low Voltage

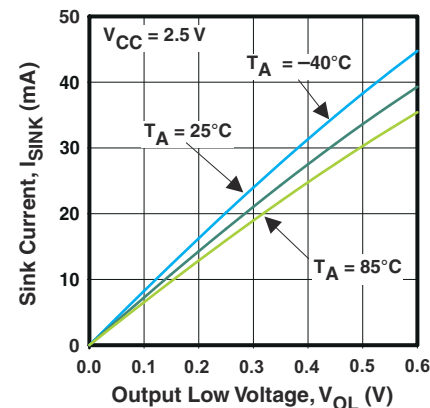

Figure 6-6. I/O Sink Current vs Output Low Voltage

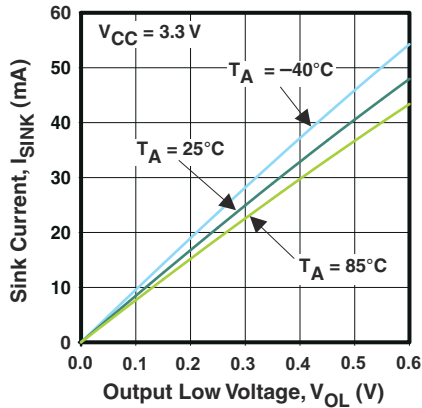

Figure 6-7. I/O Sink Current vs Output Low Voltage

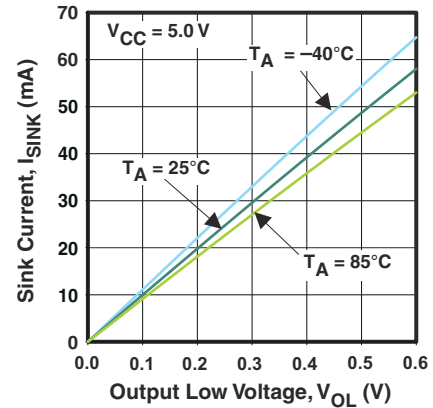

Figure 6-8. I/O Sink Current vs Output Low Voltage

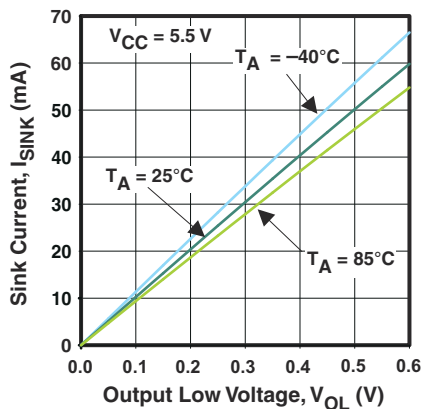

Figure 6-9. I/O Sink Current vs Output Low Voltage

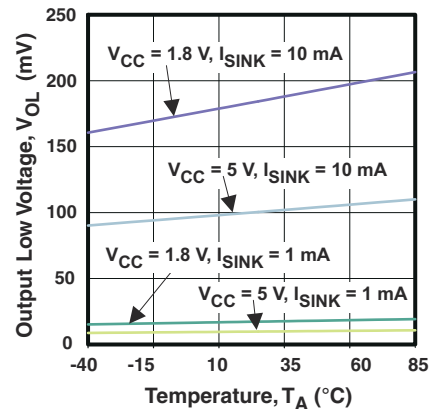

Figure 6-10. I/O Low Voltage vs Temperature

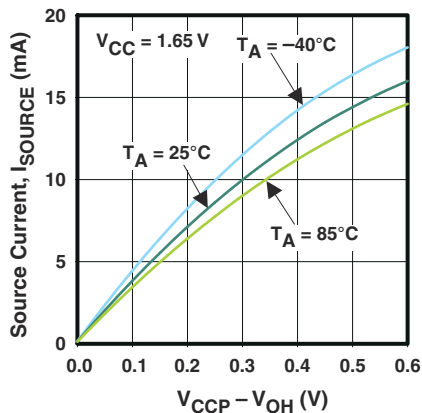

Figure 6-11. I/O Source Current vs Output High Voltage

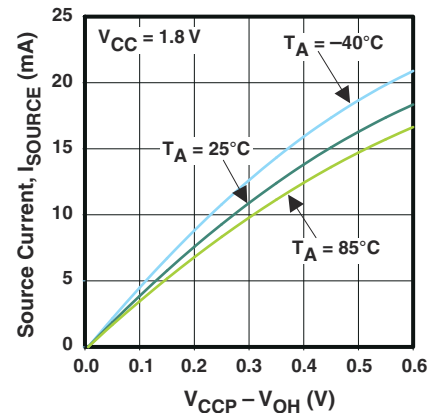

Figure 6-12. I/O Source Current vs Output High Voltage

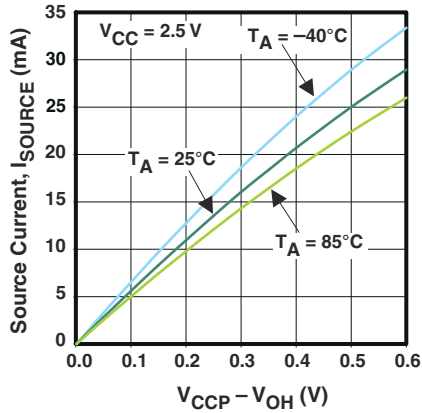

Figure 6-13. I/O Source Current vs Output High Voltage

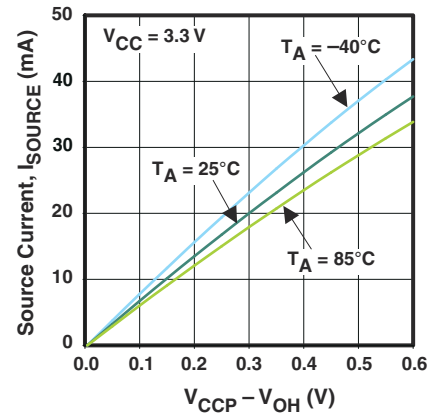

Figure 6-14. I/O Source Current vs Output High Voltage

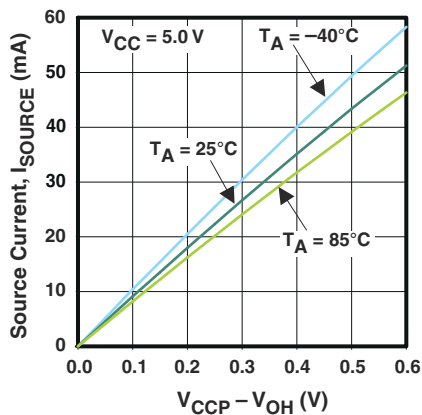

Figure 6-15. I/O Source Current vs Output High Voltage

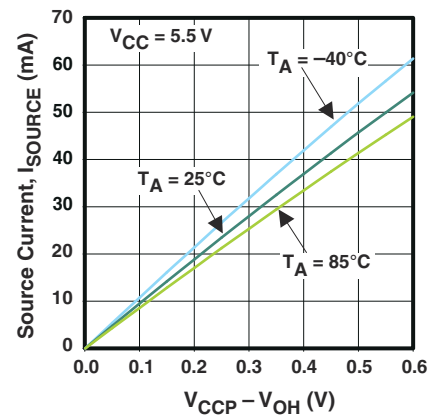

Figure 6-16. I/O Source Current vs Output High Voltage

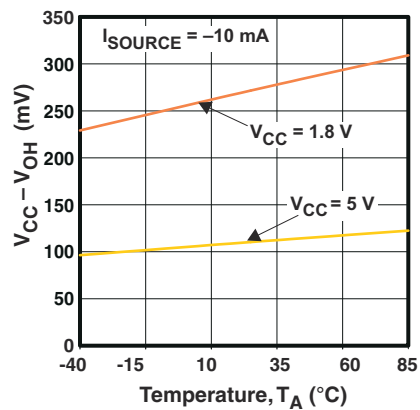
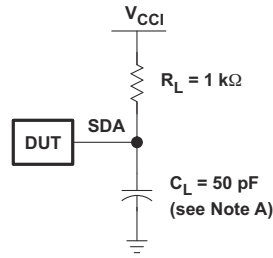
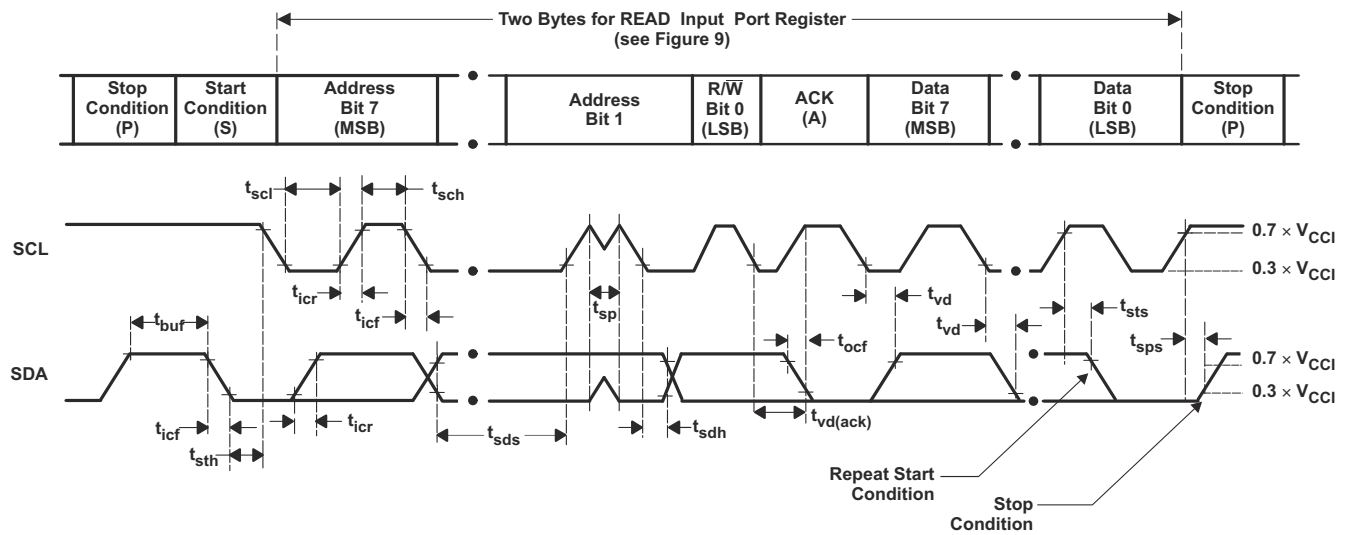

Figure 6-17. I/O High Voltage vs Temperature

## 7 Parameter Measurement Information



SDA LOAD CONFIGURATION



VOLTAGE WAVEFORMS

BYTE	DESCRIPTION
1	I <sup>2</sup> C address
2	Input register port data

- A.  $C_L$  includes probe and jig capacitance.  $t_{ocf}$  is measured with  $C_L$  of 10 pF or 400 pF.
- B. All inputs are supplied by generators having the following characteristics: PRR  $\leq$  10 MHz,  $Z_O = 50 \Omega$ ,  $t_r/t_f \leq 30$  ns.
- C. All parameters and waveforms are not applicable to all devices.

Figure 7-1. I<sup>2</sup>C Interface Load Circuit And Voltage Waveforms

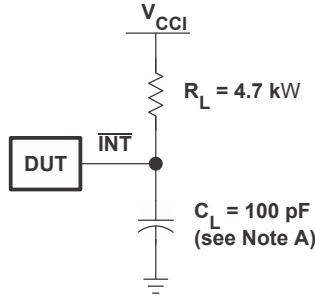

INTERRUPT LOAD CONFIGURATION

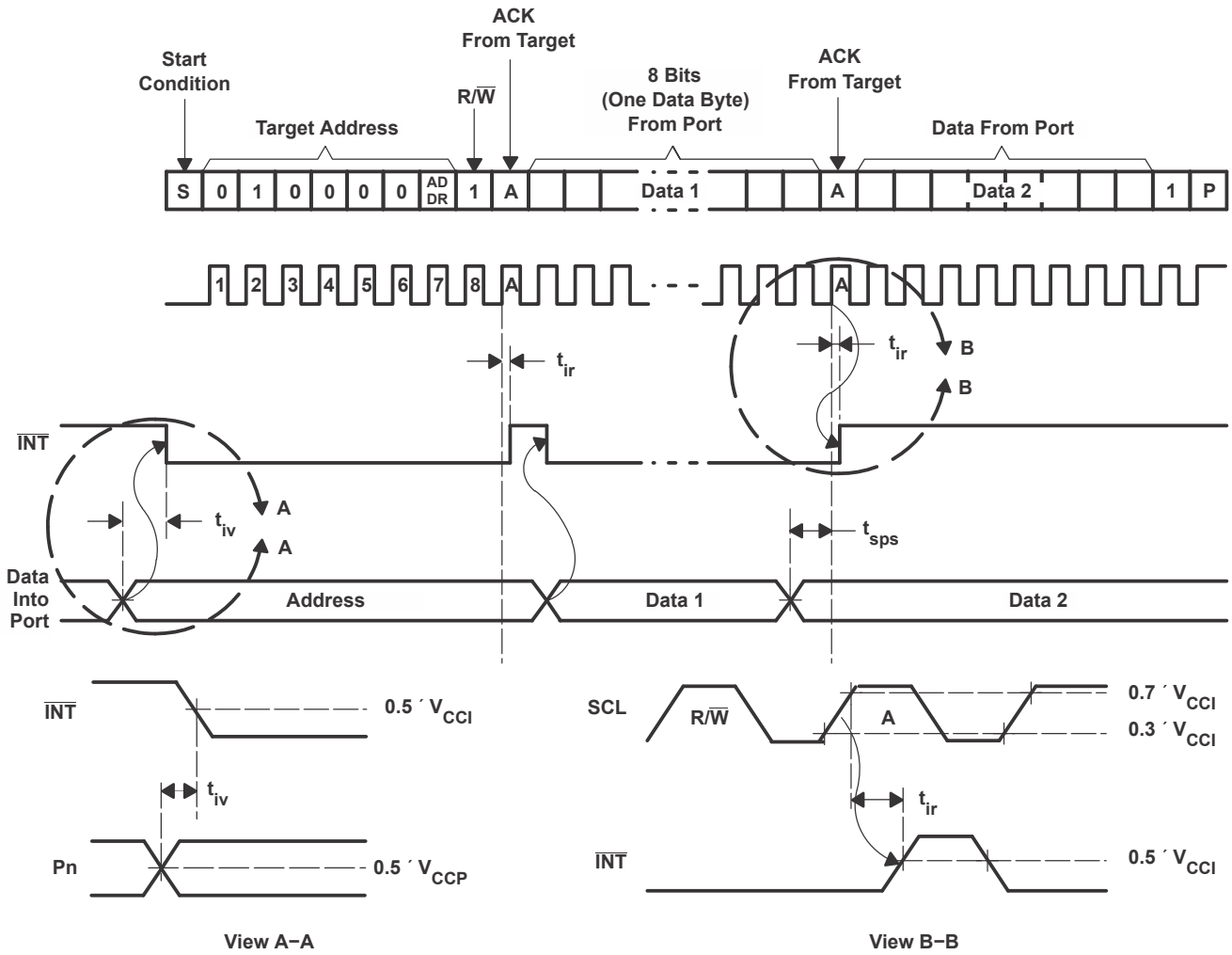

- A.  $C_L$  includes probe and jig capacitance.
- B. All inputs are supplied by generators having the following characteristics:  $PRR \leq 10 \text{ MHz}$ ,  $Z_0 = 50 \Omega$ ,  $t_r/t_f \leq 30 \text{ ns}$ .
- C. All parameters and waveforms are not applicable to all devices.

**Figure 7-2. Interrupt Load Circuit and Voltage Waveforms**

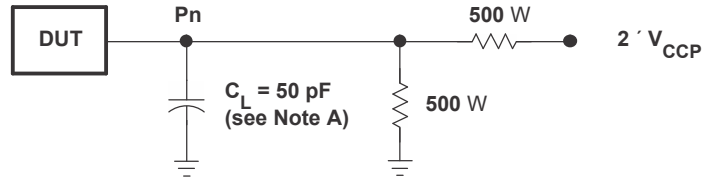

P-PORT LOAD CONFIGURATION

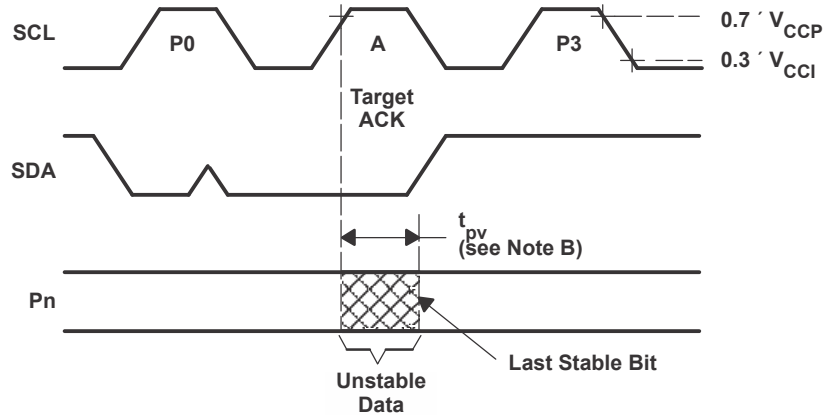

WRITE MODE (R/W = 0)

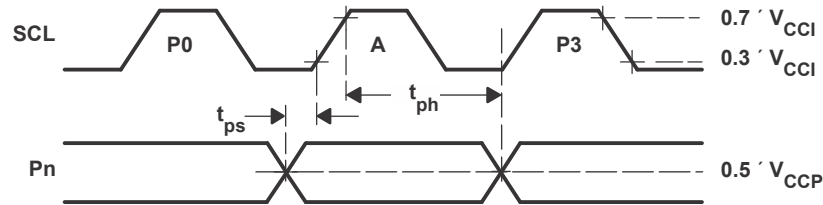

READ MODE (R/W = 1)

- A. C<sub>L</sub> includes probe and jig capacitance.
- B. t<sub>pv</sub> is measured from 0.7 × V<sub>CC</sub> on SCL to 50% I/O (Pn) output.
- C. All inputs are supplied by generators having the following characteristics: PRR ≤ 10 MHz, Z<sub>O</sub> = 50 Ω, t<sub>r</sub>/t<sub>f</sub> ≤ 30 ns.
- D. The outputs are measured one at a time, with one transition per measurement.
- E. All parameters and waveforms are not applicable to all devices.

Figure 7-3. P-Port Load Circuit and Timing Waveforms

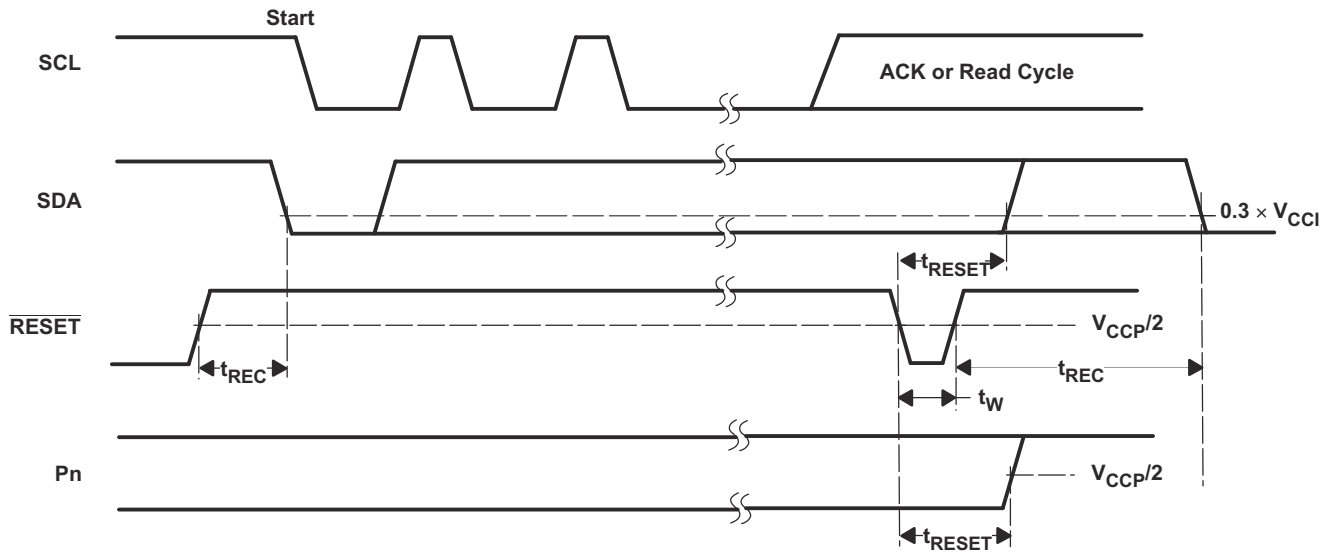
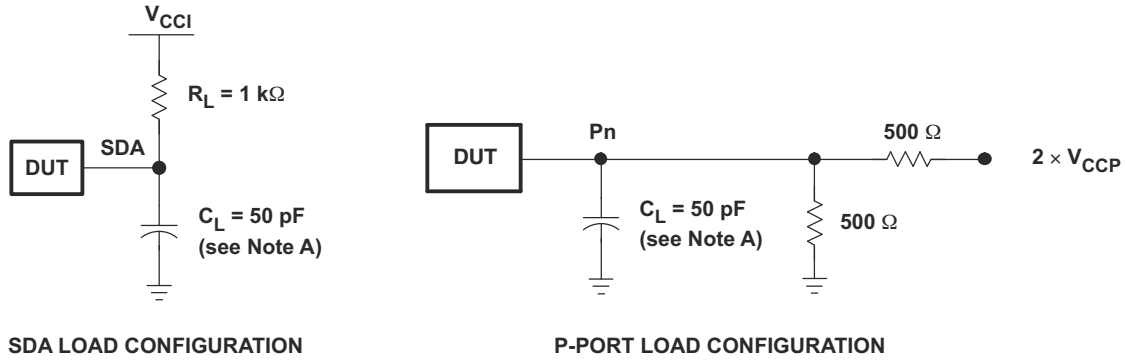

- A.  $C_L$  includes probe and jig capacitance.
- B. All inputs are supplied by generators having the following characteristics:  $PRR \leq 10\text{ MHz}$ ,  $Z_O = 50\text{ }\Omega$ ,  $t_r/t_f \leq 30\text{ ns}$ .
- C. The outputs are measured one at a time, with one transition per measurement.
- D. I/Os are configured as inputs.
- E. All parameters and waveforms are not applicable to all devices.

**Figure 7-4. Reset Load Circuits and Voltage Waveforms**

## 8 Detailed Description

### 8.1 Overview

The TCA6416A is a 16-bit I/O expander for the two-line bidirectional bus ( $I^2C$ ) is designed for 1.65-V to 5.5-V operation. It provides general-purpose remote I/O expansion and bidirectional voltage translation for processors through  $I^2C$  communication, an interface consisting of serial clock (SCL), and serial data (SDA) signals.

The major benefit of the TCA6416A is its voltage translation capability over a of a wide supply voltage range. This allows the TCA6416A to interface with modern processors on the  $I^2C$  side, where supply levels are lower to conserve power. In contrast to the dropping power supplies of processors, some PCB components such as LEDs, still require a 5-V power supply.

The VCCI pin is the power supply for the  $I^2C$  bus, and therefore the pull-up resistors connected to the SCL, SDA, INT, and RESET pins should be terminated at  $V_{CCI}$  on the opposite side. level of the  $I^2C$  bus to the TCA6416A. The VCCP pin is the power supply for the P-ports and if pull-up resistors are used on any P-port or LEDs are driven by any P-port, then the resistor(s) or LED(s) connected to P00-P07 and P10-P17 should be terminated at  $V_{CCP}$  on the opposite side. The device P-ports configured as outputs have the ability to sink up to 25 mA for directly driving LEDs, but the current must be limited externally with an additional resistance.

The features of the device include an interrupt that is generated on the  $\overline{INT}$  pin whenever an input port changes state. The devices can also be reset to its default state by applying a low logic level to the  $\overline{RESET}$  pin or by cycling power to the device and causing a power-on reset. The ADDR hardware selectable address pin allows two TCA6416A devices to be connected to the same  $I^2C$  bus.

The TCA6416A open-drain interrupt ( $\overline{INT}$ ) output is activated when any input state differs from its corresponding Input Port register state and is used to indicate to the system controller that an input state has changed. The  $\overline{INT}$  pin can be connected to the interrupt input of a processor. By sending an interrupt signal on this line, the TCA6416A can inform the processor if there is incoming data on the remote I/O ports without having to communicate via the  $I^2C$  bus. Thus, the TCA6416A can remain a simple target device.

The system controller can reset the TCA6416A in the event of a timeout or other improper operation by asserting a low on the  $\overline{RESET}$  input pin or by cycling the power to the VCCP pin and causing a power-on reset (POR). A reset puts the registers in their default state and initializes the  $I^2C$  /SMBus state machine. The  $\overline{RESET}$  feature and a POR cause the same reset/initialization to occur, but the  $\overline{RESET}$  feature does so without powering down the part.

One hardware pin (ADDR) can be used to program and vary the fixed  $I^2C$  address and allow two devices to share the same  $I^2C$  bus or SMBus.

The TCA6416A's digital core consists of eight 8-bit data registers: two Configuration registers (input or output selection), two Input Port registers, two Output Port registers, and two Polarity Inversion registers. At power on or after a reset, the I/Os are configured as inputs. However, the system controller can configure the I/Os as either inputs or outputs by writing to the Configuration registers. The data for each input or output is kept in the corresponding Input Port or Output Port register. The polarity of the Input Port register can be inverted with the Polarity Inversion register. All registers can be read by the system controller.



**Table 8-1. Voltage Translation**

$V_{CC1}$ (SDA AND SCL OF I <sup>2</sup> C CONTROLLER) (V)	$V_{CCP}$ (P-PORTS) (V)
1.8	1.8
1.8	2.5
1.8	3.3
1.8	5
2.5	1.8
2.5	2.5
2.5	3.3
2.5	5
3.3	1.8
3.3	2.5
3.3	3.3
3.3	5
5	1.8
5	2.5
5	3.3
5	5

### 8.3.2 I/O Port

When an I/O is configured as an input, FETs Q1 and Q2 are off, which creates a high-impedance input. The input voltage may be raised above  $V_{CC}$  to a maximum of 5.5 V.

If the I/O is configured as an output, Q1 or Q2 is enabled, depending on the state of the output port register. In this case, there are low-impedance paths between the I/O pin and either  $V_{CC}$  or GND. The external voltage applied to this I/O pin should not exceed the recommended levels for proper operation.

### 8.3.3 Interrupt Output ( $\overline{INT}$ )

An interrupt is generated by any rising or falling edge of the port inputs in the input mode. After time  $t_{iv}$ , the signal  $\overline{INT}$  is valid. Resetting the interrupt circuit is achieved when data on the port is changed to the original setting or when data is read from the port that generated the interrupt. Resetting occurs in the read mode at the acknowledge (ACK) or not acknowledge (NACK) bit after the rising edge of the SCL signal. Interrupts that occur during the ACK or NACK clock pulse can be lost (or be very short) due to the resetting of the interrupt during this pulse. Each change of the I/Os after resetting is detected and is transmitted as  $\overline{INT}$ .

Reading from or writing to another device does not affect the interrupt circuit, and a pin configured as an output cannot cause an interrupt. Changing an I/O from an output to an input may cause a false interrupt to occur, if the state of the pin does not match the contents of the Input Port register.

The  $\overline{INT}$  output has an open-drain structure and requires pull-up resistor to  $V_{CCP}$  or  $V_{CC1}$  depending on the application.  $\overline{INT}$  should be connected to the voltage source of the device that requires the interrupt information.

### 8.3.4 Reset Input ( $\overline{RESET}$ )

The  $\overline{RESET}$  input can be asserted to initialize the system while keeping the  $V_{CCP}$  at its operating level. A reset can be accomplished by holding the  $\overline{RESET}$  pin low for a minimum of  $t_w$ . The TCA6416A registers and I<sup>2</sup>C/SMBus state machine are changed to their default state once  $\overline{RESET}$  is low (0). When  $\overline{RESET}$  is high (1), the I/O levels at the P port can be changed externally or through the controller. This input requires a pull-up resistor to  $V_{CC1}$ , if no active connection is used.

## 8.4 Device Functional Modes

### 8.4.1 Power-On Reset

When power (from 0 V) is applied to  $V_{CCP}$ , an internal power-on reset holds the TCA6416A in a reset condition until  $V_{CCP}$  has reached  $V_{POR}$ . At that time, the reset condition is released, and the TCA6416A registers and I<sup>2</sup>C/SMBus state machine initializes to their default states. After that,  $V_{CCP}$  must be lowered to below  $V_{PORF}$  and back up to the operating voltage for a power-reset cycle.

## 8.5 Programming

### 8.5.1 I<sup>2</sup>C Interface

The bidirectional I<sup>2</sup>C bus consists of the serial clock (SCL) and serial data (SDA) lines. Both lines must be connected to a positive supply through a pull-up resistor when connected to the output stages of a device. Data transfer may be initiated only when the bus is not busy.

I<sup>2</sup>C communication with this device is initiated by a controller sending a Start condition, a high-to-low transition on the SDA input/output, while the SCL input is high (see Figure 8-3). After the Start condition, the device address byte is sent, most significant bit (MSB) first, including the data direction bit (R/  $\bar{W}$ ).

After receiving the valid address byte, this device responds with an acknowledge (ACK), a low on the SDA input/output during the high of the ACK-related clock pulse. The address (ADDR) input of the target device must not be changed between the Start and the Stop conditions.

On the I<sup>2</sup>C bus, only one data bit is transferred during each clock pulse. The data on the SDA line must remain stable during the high pulse of the clock period, as changes in the data line at this time are interpreted as control commands (Start or Stop) (see Figure 8-4).

A Stop condition, a low-to-high transition on the SDA input/output while the SCL input is high, is sent by the controller (see Figure 8-3).

Any number of data bytes can be transferred from the transmitter to receiver between the Start and the Stop conditions. Each byte of eight bits is followed by one ACK bit. The transmitter must release the SDA line before the receiver can send an ACK bit. The device that acknowledges must pull down the SDA line during the ACK clock pulse, so that the SDA line is stable low during the high pulse of the ACK-related clock period (see Figure 8-5). When a target receiver is addressed, it must generate an ACK after each byte is received. Similarly, the controller must generate an ACK after each byte that it receives from the target transmitter. Setup and hold times must be met to ensure proper operation.

A controller receiver signals an end of data to the target transmitter by not generating an acknowledge (NACK) after the last byte has been clocked out of the target. This is done by the controller receiver by holding the SDA line high. In this event, the transmitter must release the data line to enable the controller to generate a Stop condition.

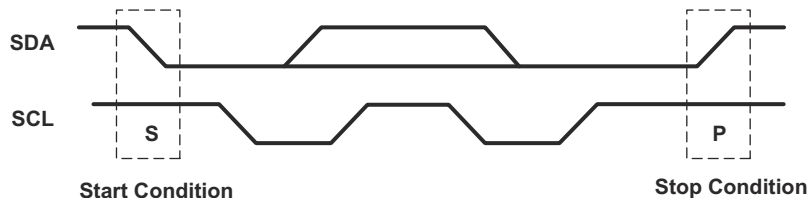

**Figure 8-3. Definition of Start and Stop Conditions**

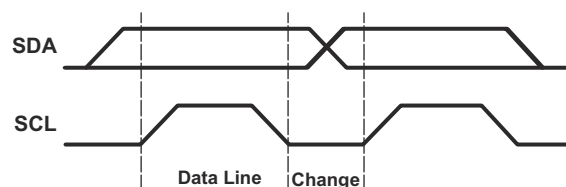

**Figure 8-4. Bit Transfer**

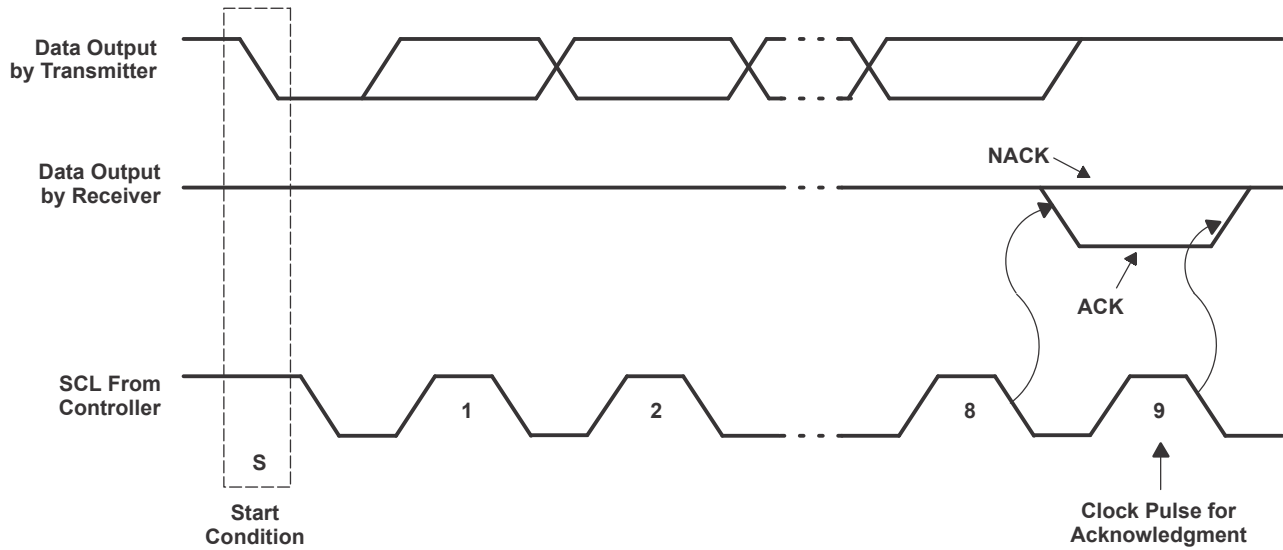

Figure 8-5. Acknowledgment on the I<sup>2</sup>C Bus

Table 8-2. Interface Definition

BYTE	BIT							
	7 (MSB)	6	5	4	3	2	1	0 (LSB)
I <sup>2</sup> C target address	L	H	L	L	L	L	ADDR	R/ W
I/O data bus	P07	P06	P05	P04	P03	P02	P01	P00
	P17	P16	P15	P14	P13	P12	P11	P10

## 8.6 Register Maps

### 8.6.1 Device Address

The address of the TCA6416A is shown in Figure 8-6.

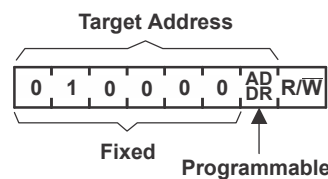

Figure 8-6. TCA6416A Address

Table 8-3. Address Reference

ADDR	I <sup>2</sup> C BUS TARGET ADDRESS
L	32 (decimal), 20 (hexadecimal)
H	33 (decimal), 21 (hexadecimal)

The last bit of the target address defines the operation (read or write) to be performed. A high (1) selects a read operation, while a low (0) selects a write operation.

### 8.6.2 Control Register and Command Byte

Following the successful acknowledgment of the address byte, the bus controller sends a command byte, which is stored in the control register in the TCA6416A. Three bits of this data byte state the operation (read or write) and the internal registers (input, output, polarity inversion, or configuration) that will be affected. This register can be written or read through the I<sup>2</sup>C bus. The command byte is sent only during a write transmission.

Once a new command has been sent, the register that was addressed continues to be accessed by reads until a new command byte has been sent.

B7	B6	B5	B4	B3	B2	B1	B0
----	----	----	----	----	----	----	----

**Figure 8-7. Control Register Bits**

**Table 8-4. Command Byte**

CONTROL REGISTER BITS								COMMAND BYTE (HEX)	REGISTER	PROTOCOL	POWER-UP DEFAULT
B7	B6	B5	B4	B3	B2	B1	B0				
0	0	0	0	0	0	0	0	00	Input Port 0	Read byte	xxxx xxxx <sup>(1)</sup>
0	0	0	0	0	0	0	1	01	Input Port 1	Read byte	xxxx xxxx <sup>(1)</sup>
0	0	0	0	0	0	1	0	02	Output Port 0	Read/write byte	1111 1111
0	0	0	0	0	0	1	1	03	Output Port 1	Read/write byte	1111 1111
0	0	0	0	0	1	0	0	04	Polarity Inversion 0	Read/write byte	0000 0000
0	0	0	0	0	1	0	1	05	Polarity Inversion 1	Read/write byte	0000 0000
0	0	0	0	0	1	1	0	06	Configuration 0	Read/write byte	1111 1111
0	0	0	0	0	1	1	1	07	Configuration 1	Read/write byte	1111 1111

(1) Undefined

### 8.6.3 Register Descriptions

The Input Port registers (registers 0 and 1) reflect the incoming logic levels of the pins, regardless of whether the pin is defined as an input or an output by the Configuration register. They act only on read operation. Writes to these registers have no effect. The default value (X) is determined by the externally applied logic level. Before a read operation, a write transmission is sent with the command byte to indicate to the I<sup>2</sup>C device that the Input Port register will be accessed next.

**Table 8-5. Registers 0 and 1 (Input Port Registers)**

BIT	I-07	I-06	I-05	I-04	I-03	I-02	I-01	I-00
DEFAULT	X	X	X	X	X	X	X	X
BIT	I-17	I-16	I-15	I-14	I-13	I-12	I-11	I-10
DEFAULT	X	X	X	X	X	X	X	X

The Output Port registers (registers 2 and 3) shows the outgoing logic levels of the pins defined as outputs by the Configuration register. Bit values in these registers have no effect on pins defined as inputs. In turn, reads from these registers reflect the value that is in the flip-flop controlling the output selection, not the actual pin value.

**Table 8-6. Registers 2 and 3 (Output Port Registers)**

BIT	O-07	O-06	O-05	O-04	O-03	O-02	O-01	O-00
DEFAULT	1	1	1	1	1	1	1	1
BIT	O-17	O-16	O-15	O-14	O-13	O-12	O-11	O-10
DEFAULT	1	1	1	1	1	1	1	1

The Polarity Inversion registers (register 4 and 5) allow polarity inversion of pins defined as inputs by the Configuration register. If a bit in these registers is set (written with 1), the corresponding port pin's polarity is inverted. If a bit in these registers is cleared (written with a 0), the corresponding port pin's original polarity is retained.

**Table 8-7. Registers 4 and 5 (Polarity Inversion Registers)**

BIT	P-07	P-06	P-05	P-04	P-03	P-02	P-01	P-00
DEFAULT	0	0	0	0	0	0	0	0

**Table 8-7. Registers 4 and 5 (Polarity Inversion Registers) (continued)**

BIT	P-17	P-16	P-15	P-14	P-13	P-12	P-11	P-10
DEFAULT	0	0	0	0	0	0	0	0

The Configuration registers (registers 6 and 7) configure the direction of the I/O pins. If a bit in these registers is set to 1, the corresponding port pin is enabled as an input with a high-impedance output driver. If a bit in these registers is cleared to 0, the corresponding port pin is enabled as an output.

**Table 8-8. Registers 6 and 7 (Configuration Registers)**

BIT	C-07	C-06	C-05	C-04	C-03	C-02	C-01	C-00
DEFAULT	1	1	1	1	1	1	1	1
BIT	C-17	C-16	C-15	C-14	C-13	C-12	C-11	C-10
DEFAULT	1	1	1	1	1	1	1	1

### 8.6.4 Bus Transactions

Data is exchanged between the controller and TCA6416A through write and read commands.

#### 8.6.4.1 Writes

Data is transmitted to the TCA6416A by sending the device address and setting the least-significant bit (LSB) to a logic 0 (see Figure 8-6 for device address). The command byte is sent after the address and determines which register receives the data that follows the command byte. There is no limitation on the number of data bytes sent in one write transmission.

The eight registers within the TCA6416A are configured to operate as four register pairs. The four pairs are input ports, output ports, polarity inversion ports and configuration ports. After sending data to one register, the next data byte is sent to the other register in the pair (see Figure 8-8 and Figure 8-9). For example, if the first byte is sent to Output Port 1 (register 3), the next byte is stored in Output Port 0 (register 2).

There is no limitation on the number of data bytes sent in one write transmission. In this way, each 8-bit register may be updated independently of the other registers.

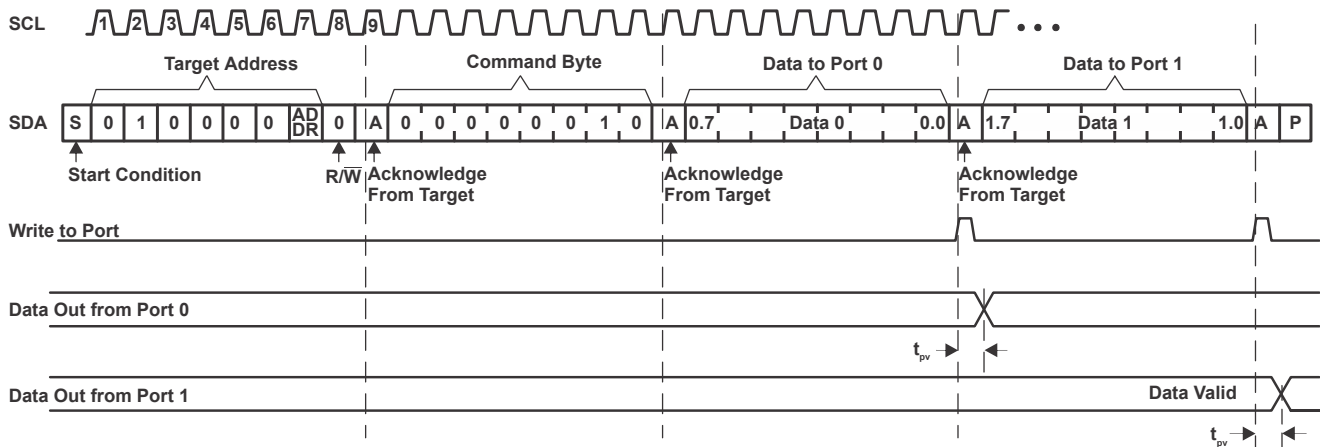

**Figure 8-8. Write to Output Port Register**

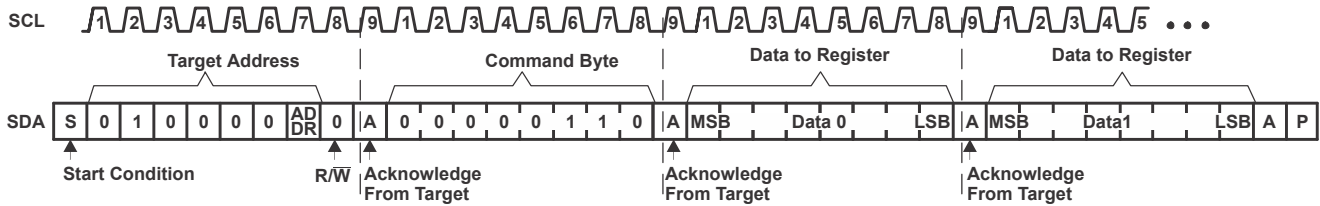

**Figure 8-9. Write to Configuration or Polarity Inversion Registers**

**8.6.4.2 Reads**

The bus controller first must send the TCA6416A address with the LSB set to a logic 0 (see Figure 8-6 for device address). The command byte is sent after the address and determines which register is accessed.

After a restart, the device address is sent again but, this time, the LSB is set to a logic 1. Data from the register defined by the command byte then is sent by the TCA6416A (see Figure 8-10 and Figure 8-11).

After a restart, the value of the register defined by the command byte matches the register being accessed when the restart occurred. For example, if the command byte references Input Port 1 before the restart, and the restart occurs when Input Port 0 is being read, the stored command byte changes to reference Input Port 0. The original command byte is forgotten. If a subsequent restart occurs, Input Port 0 is read first. Data is clocked into the register on the rising edge of the ACK clock pulse. After the first byte is read, additional bytes may be read, but the data now reflects the information in the other register in the pair. For example, if Input Port 1 is read, the next byte read is Input Port 0.

Data is clocked into the register on the rising edge of the ACK clock pulse. There is no limitation on the number of data bytes received in one read transmission, but when the final byte is received, the bus controller must not acknowledge the data.

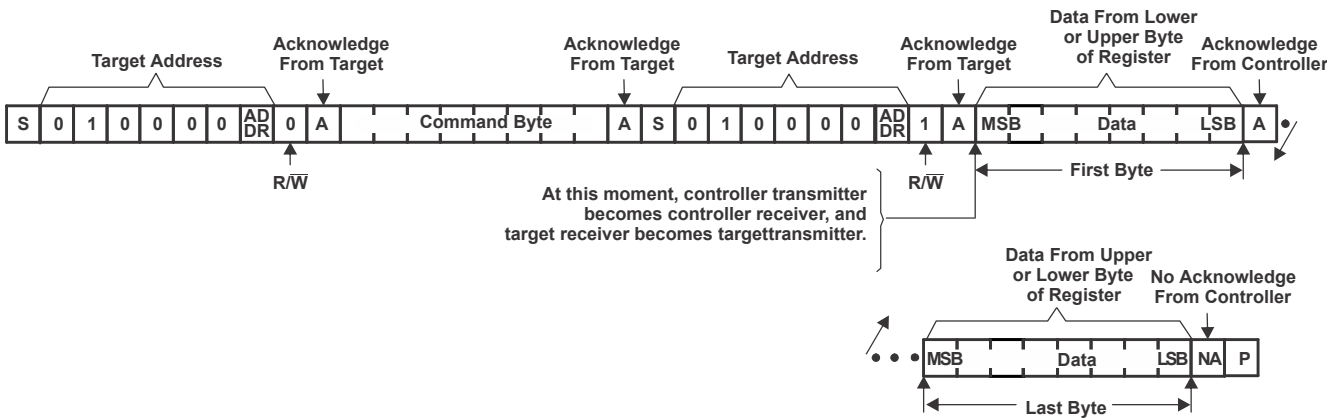

**Figure 8-10. Read From Register**

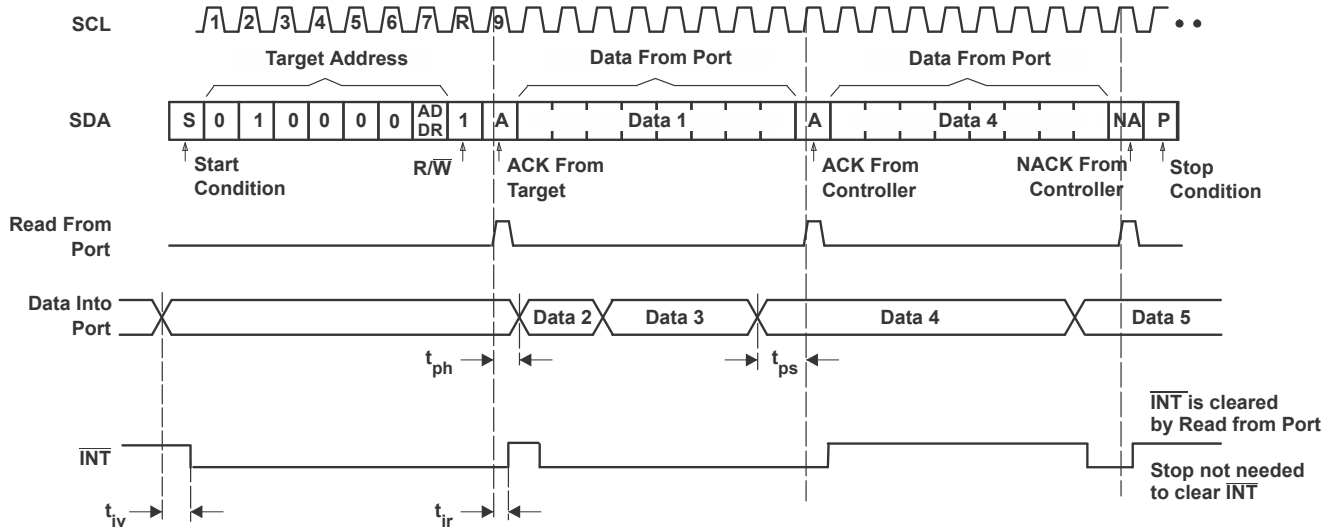

- Transfer of data can be stopped at any time by a Stop condition. When this occurs, data present at the latest acknowledge phase is valid (output mode). It is assumed that the command byte previously has been set to 00 (read Input Port register).
- This figure eliminates the command byte transfer, a restart, and target address call between the initial target address call and actual data transfer from P port (see [Figure 8-10](#)).

**Figure 8-11. Read Input Port Register**

## 9 Application and Implementation

### Note

Information in the following applications sections is not part of the TI component specification, and TI does not warrant its accuracy or completeness. TI's customers are responsible for determining suitability of components for their purposes. Customers should validate and test their design implementation to confirm system functionality.

### 9.1 Application Information

Applications of the TCA6416A will have this device connected as a target to an I2C controller (processor), and the I2C bus may contain any number of other target devices. The TCA6416A will be in a remote location from the controller, placed close to the GPIOs to which the controller needs to monitor or control.

A typical application of the TCA6416A will operate with a lower voltage on the controller side ( $V_{CCI}$ ), and a higher voltage on the P-port side ( $V_{CCP}$ ). The P-ports can be configured as outputs connected to inputs of devices such as enable, reset, power select, the gate of a switch, and LEDs. The P-ports can also be configured as inputs to receive data from interrupts, alarms, status outputs, or push buttons.

### 9.2 Typical Application

Figure 9-1 shows an application in which the TCA6416A can be used.

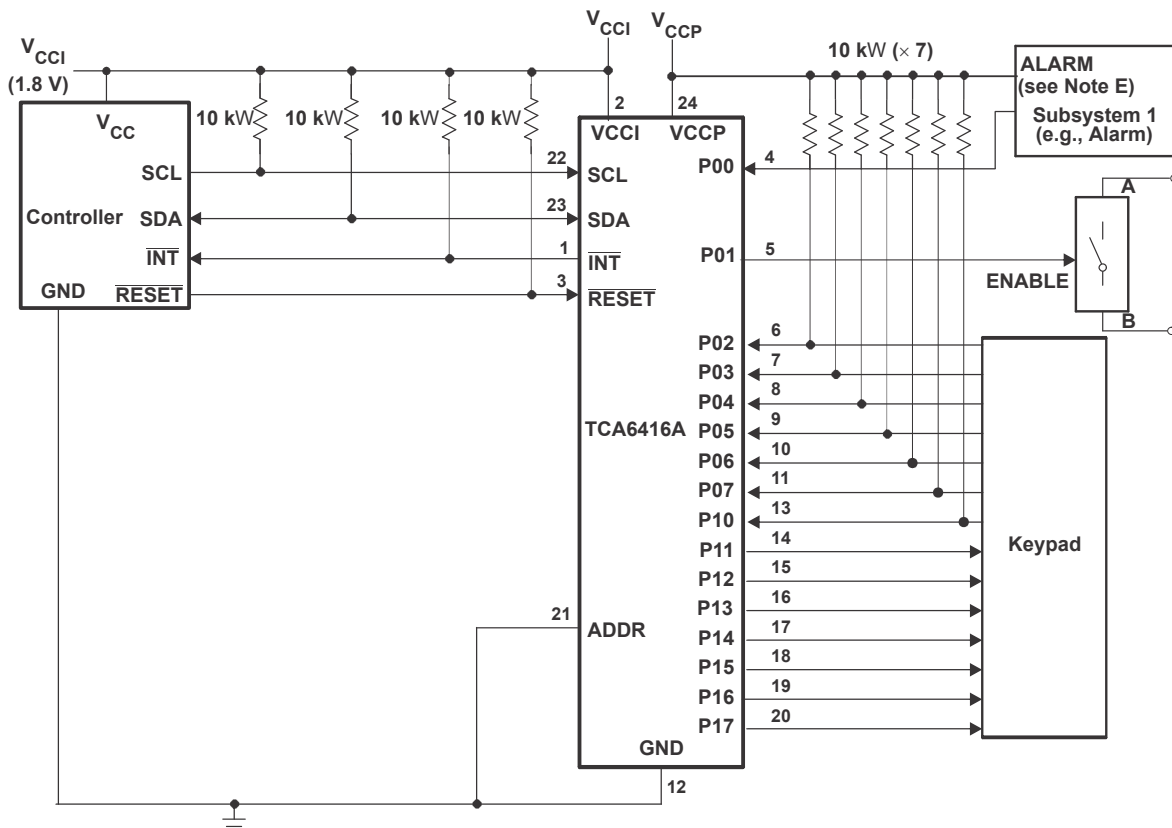

- Device address configured as 0100000 for this example.
- P00 and P02–P10 are configured as inputs.
- P01 and P11–P17 are configured as outputs.
- Pin numbers shown are for the PW package.

- E. Resistors are required for inputs (on P port) that may float. If a driver to an input will never let the input float, a resistor is not needed. Outputs (in the P port) do not need pullup resistors.

**Figure 9-1. Typical Application Schematic**

### 9.2.1 Design Requirements

**Table 9-1. Design Parameters**

DESIGN PARAMETER	EXAMPLE VALUE
I <sup>2</sup> C input voltage (V <sub>CCI</sub> )	1.8 V
P-port input/output voltage (V <sub>CCP</sub> )	5 V
Output current rating, P-port sinking (I <sub>OL</sub> )	25 mA
Output current rating, P-port sourcing (I <sub>OH</sub> )	10 mA
I <sup>2</sup> C bus clock (SCL) speed	400 kHz

### 9.2.2 Detailed Design Procedure

The pull-up resistors, R<sub>P</sub>, for the SCL and SDA lines need to be selected appropriately and take into consideration the total capacitance of all targets on the I<sup>2</sup>C bus. The minimum pull-up resistance is a function of V<sub>CC</sub>, V<sub>OL(max)</sub>, and I<sub>OL</sub>:

$$R_{p(\min)} = \frac{V_{CC} - V_{OL(\max)}}{I_{OL}} \quad (1)$$

The maximum pull-up resistance is a function of the maximum rise time, t<sub>r</sub> (300 ns for fast-mode operation, f<sub>SCL</sub> = 400 kHz) and bus capacitance, C<sub>b</sub>:

$$R_{p(\max)} = \frac{t_r}{0.8473 \times C_b} \quad (2)$$

The maximum bus capacitance for an I<sup>2</sup>C bus must not exceed 400 pF for standard-mode or fast-mode operation. The bus capacitance can be approximated by adding the capacitance of the TCA9538, C<sub>i</sub> for SCL or C<sub>io</sub> for SDA, the capacitance of wires/connections/traces, and the capacitance of additional targets on the bus.

#### 9.2.2.1 Minimizing I<sub>CC</sub> When I/Os Control LEDs

When the I/Os are used to control LEDs, normally they are connected to V<sub>CC</sub> through a resistor as shown in [Figure 9-2](#). For a P-port configured as an input, I<sub>CC</sub> increases as V<sub>I</sub> becomes lower than V<sub>CC</sub>. The LED is a diode, with threshold voltage V<sub>T</sub>, and when a P-port is configured as an input the LED will be off but V<sub>I</sub> is a V<sub>T</sub> drop below V<sub>CC</sub>.

For battery-powered applications, it is essential that the voltage of P-ports controlling LEDs is greater than or equal to V<sub>CC</sub> when the P-ports are configured as input to minimize current consumption. [Figure 9-2](#) shows a high-value resistor in parallel with the LED. [Figure 9-3](#) shows V<sub>CC</sub> less than the LED supply voltage by at least V<sub>T</sub>. Both of these methods maintain the I/O V<sub>I</sub> at or above V<sub>CC</sub> and prevents additional supply current consumption when the P-port is configured as an input and the LED is off.

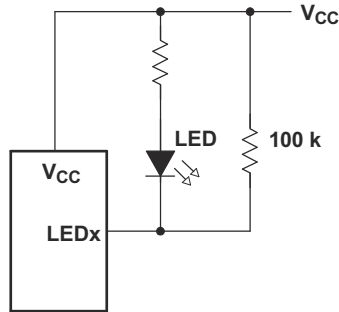

Figure 9-2. High-Value Resistor in Parallel With LED

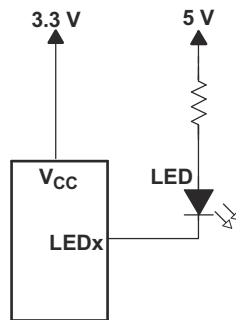
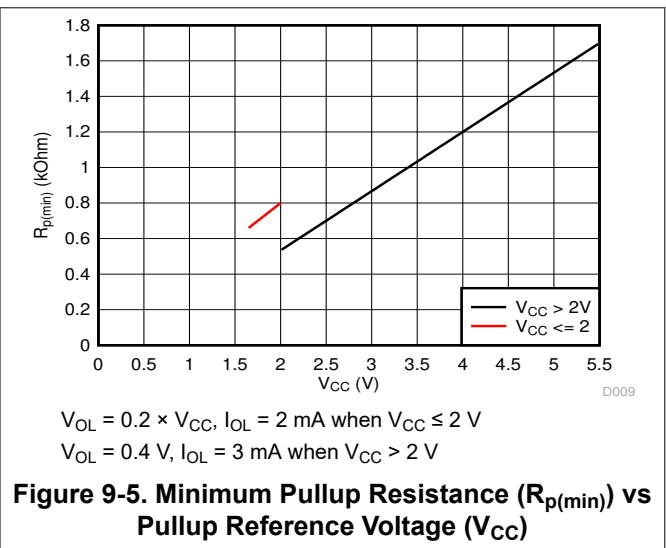
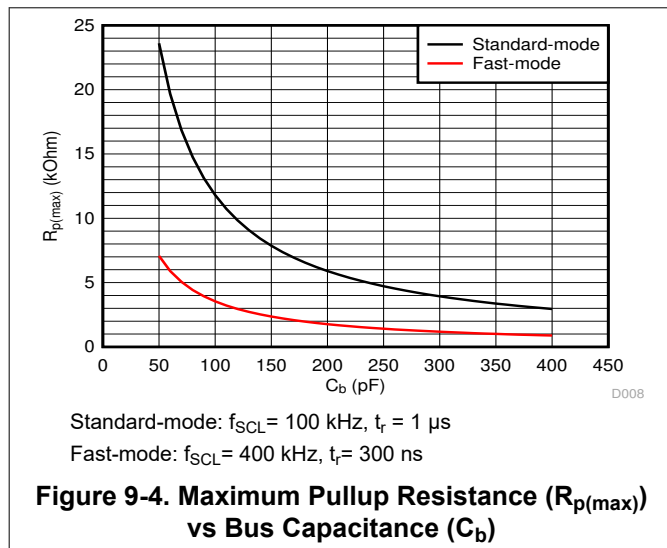

Figure 9-3. Device Supplied by a Lower Voltage

9.2.3 Application Curves



## 10 Power Supply Recommendations

### 10.1 Power-On Reset Requirements

In the event of a glitch or data corruption, TCA6416A can be reset to its default conditions by using the power-on reset feature. Power-on reset requires that the device go through a power cycle to be completely reset. This reset also happens when the device is powered on for the first time in an application.

Ramping up the device  $V_{CCP}$  before  $V_{CCI}$  is recommended to prevent SDA from potentially being stuck LOW.

The two types of power-on reset are shown in [Figure 10-1](#) and [Figure 10-2](#).

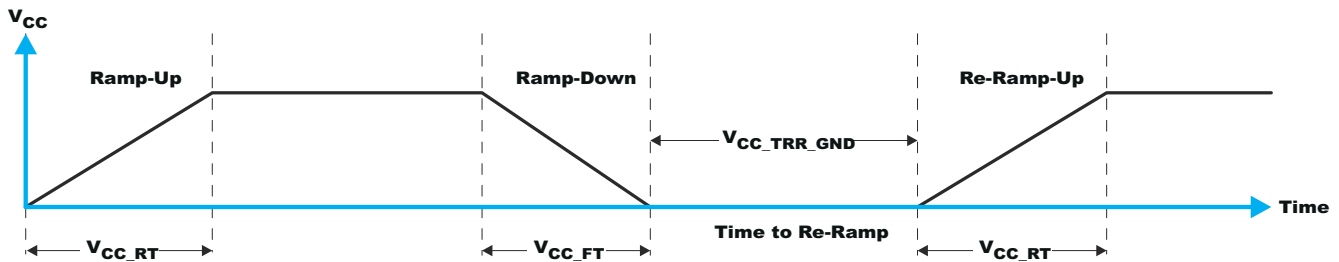

Figure 10-1.  $V_{CC}$  is Lowered Below 0.2 V or 0 V and Then Ramped up to  $V_{CC}$

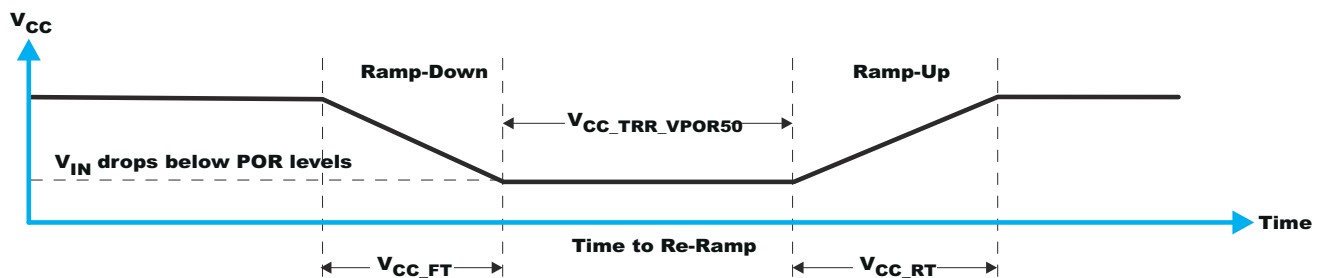

Figure 10-2.  $V_{CC}$  is Lowered Below the POR Threshold, Then Ramped Back up to  $V_{CC}$

[Table 10-1](#) specifies the performance of the power-on reset feature for TCA6416A for both types of power-on reset.

Table 10-1. Recommended Supply Sequencing and Ramp Rates

PARAMETER <sup>(1) (2)</sup>		MIN	TYP	MAX	UNIT
$t_{FT}$	Fall rate	See <a href="#">Figure 10-1</a>	0.1	2000	ms
$t_{RT}$	Rise rate	See <a href="#">Figure 10-1</a>	0.1	2000	ms
$t_{TRR\_GND}$	Time to re-ramp (when $V_{CC}$ drops to GND)	See <a href="#">Figure 10-1</a>	1		$\mu$ s
$t_{TRR\_POR50}$	Time to re-ramp (when $V_{CC}$ drops to $V_{POR\_MIN} - 50$ mV)	See <a href="#">Figure 10-2</a>	1		$\mu$ s
$V_{CC\_GH}$	Level that $V_{CCP}$ can glitch down to, but not cause a functional disruption when $V_{CCX\_GW} = 1$ $\mu$ s	See <a href="#">Figure 10-3</a>		1.2	V
$t_{GW}$	Glitch width that will not cause a functional disruption when $V_{CCX\_GH} = 0.5 \times V_{CCX}$	See <a href="#">Figure 10-3</a>		10	$\mu$ s
$V_{PORF}$	Voltage trip point of POR on falling $V_{CC}$		0.7		V
$V_{PORR}$	Voltage trip point of POR on rising $V_{CC}$			1.4	V

(1)  $T_A = 25^\circ\text{C}$  (unless otherwise noted).

(2) Not tested. Specified by design.

Glitches in the power supply can also affect the power-on reset performance of this device. The glitch width ( $V_{CC\_GW}$ ) and height ( $V_{CC\_GH}$ ) are dependent on each other. The bypass capacitance, source impedance, and device impedance are factors that affect power-on reset performance. [Figure 10-3](#) and [Table 10-1](#) provide more information on how to measure these specifications.

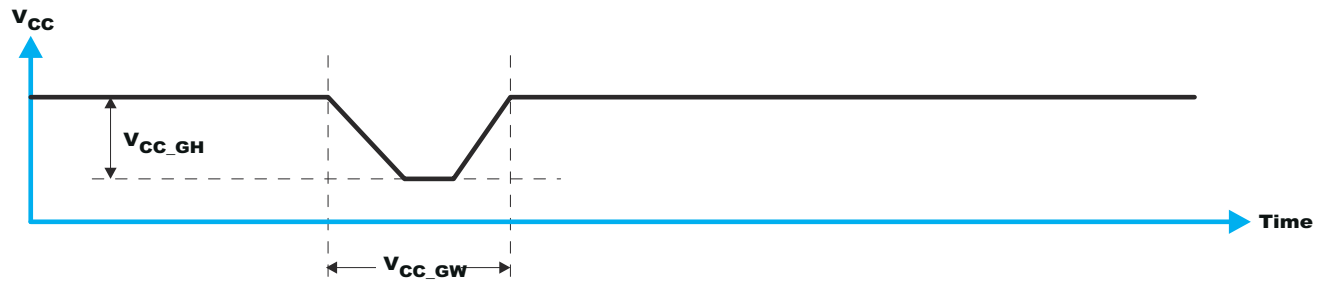

Figure 10-3. Glitch Width and Glitch Height

$V_{POR}$  is critical to the power-on reset.  $V_{POR}$  is the voltage level at which the reset condition is released and all the registers and the I<sup>2</sup>C/SMBus state machine are initialized to the default states. The value of  $V_{POR}$  differs based on the  $V_{CC}$  being lowered to or from 0. Figure 10-4 and Table 10-1 provide more details on this specification.

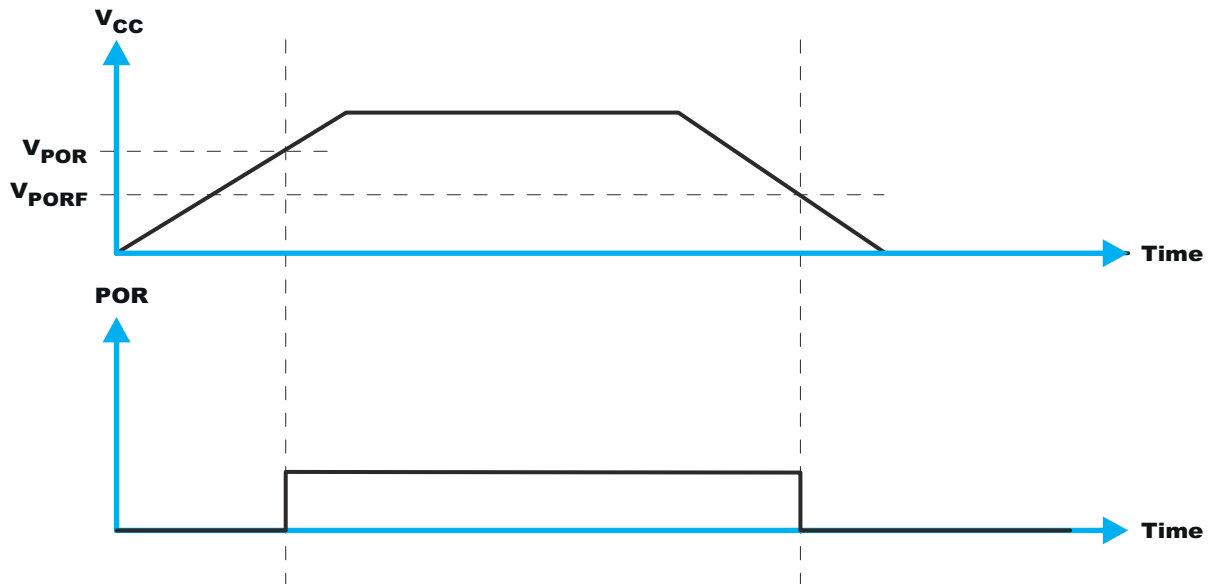

Figure 10-4.  $V_{POR}$

## 11 Layout

### 11.1 Layout Guidelines

For printed circuit board (PCB) layout of the TCA6416A, common PCB layout practices should be followed but additional concerns related to high-speed data transfer such as matched impedances and differential pairs are not a concern for I<sup>2</sup>C signal speeds.

In all PCB layouts, it is a best practice to avoid right angles in signal traces, to fan out signal traces away from each other upon leaving the vicinity of an integrated circuit (IC), and to use thicker trace widths to carry higher amounts of current that commonly pass through power and ground traces. By-pass and de-coupling capacitors are commonly used to control the voltage on the VCCP pin, using a larger capacitor to provide additional power in the event of a short power supply glitch and a smaller capacitor to filter out high-frequency ripple. These capacitors should be placed as close to the TCA6416A as possible. These best practices are shown in [Figure 11-1](#).

For the layout example provided in [Figure 11-1](#), it would be possible to fabricate a PCB with only 2 layers by using the top layer for signal routing and the bottom layer as a split plane for power ( $V_{CCI}$  and  $V_{CCP}$ ) and ground (GND). However, a 4 layer board is preferable for boards with higher density signal routing. On a 4 layer PCB, it is common to route signals on the top and bottom layer, dedicate one internal layer to a ground plane, and dedicate the other internal layer to a power plane. In a board layout using planes or split planes for power and ground, vias are placed directly next to the surface mount component pad which needs to attach to  $V_{CCI}$ ,  $V_{CCP}$ , or GND and the via is connected electrically to the internal layer or the other side of the board. Vias are also used when a signal trace needs to be routed to the opposite side of the board, but this technique is not demonstrated in [Figure 11-1](#).

## 11.2 Layout Example

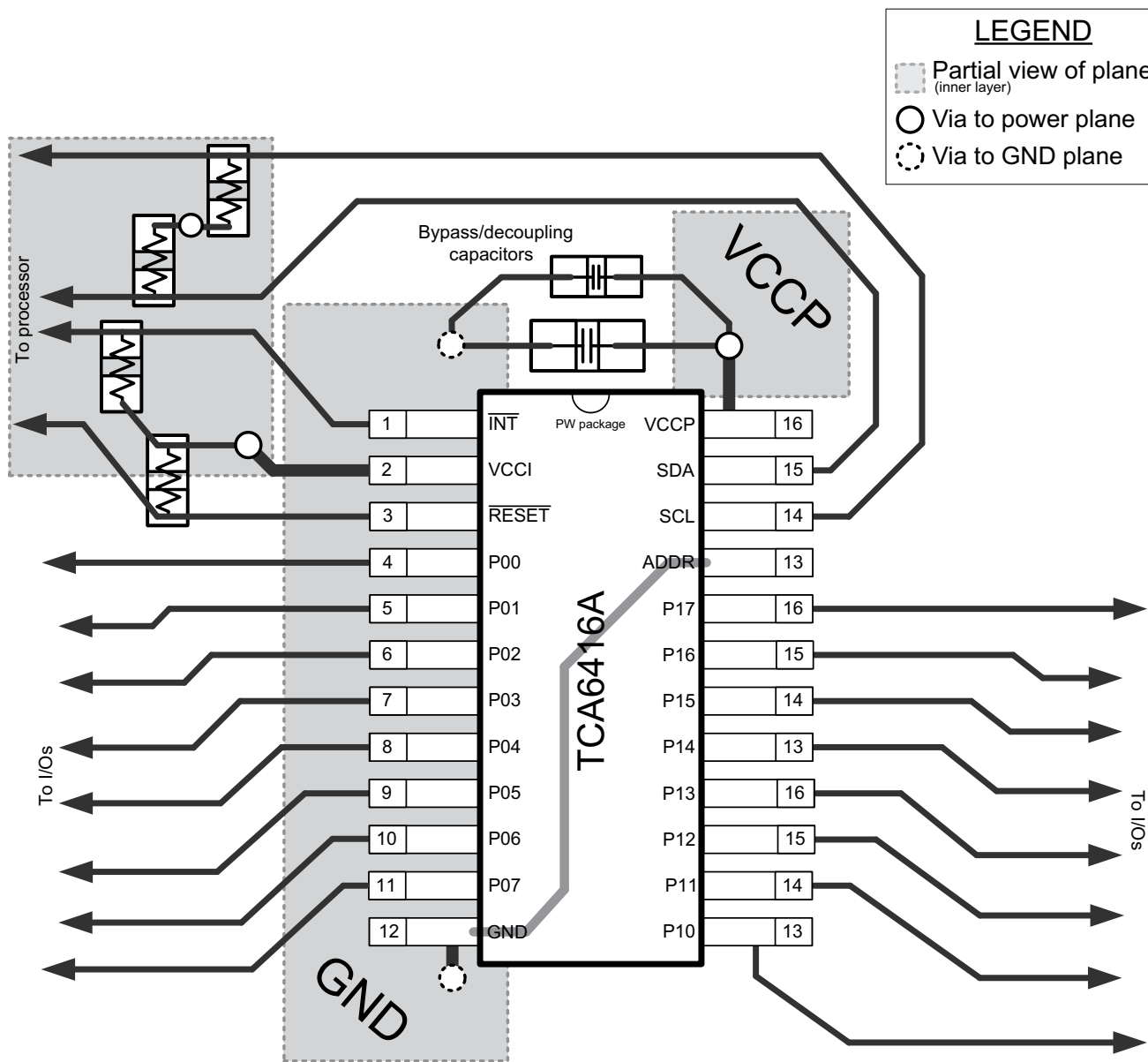

Figure 11-1. TCA6416A Layout

## 12 Device and Documentation Support

### 12.1 Receiving Notification of Documentation Updates

To receive notification of documentation updates, navigate to the device product folder on [ti.com](http://ti.com). Click on *Subscribe to updates* to register and receive a weekly digest of any product information that has changed. For change details, review the revision history included in any revised document.

### 12.2 Support Resources

[TI E2E™ support forums](#) are an engineer's go-to source for fast, verified answers and design help — straight from the experts. Search existing answers or ask your own question to get the quick design help you need.

Linked content is provided "AS IS" by the respective contributors. They do not constitute TI specifications and do not necessarily reflect TI's views; see TI's [Terms of Use](#).

### 12.3 Trademarks

Microstar BGA™ is a trademark of TI.

TI E2E™ is a trademark of Texas Instruments.

All trademarks are the property of their respective owners.

### 12.4 Electrostatic Discharge Caution



This integrated circuit can be damaged by ESD. Texas Instruments recommends that all integrated circuits be handled with appropriate precautions. Failure to observe proper handling and installation procedures can cause damage.

ESD damage can range from subtle performance degradation to complete device failure. Precision integrated circuits may be more susceptible to damage because very small parametric changes could cause the device not to meet its published specifications.

### 12.5 Glossary

[TI Glossary](#) This glossary lists and explains terms, acronyms, and definitions.

## 13 Mechanical, Packaging, and Orderable Information

The following pages include mechanical, packaging, and orderable information. This information is the most current data available for the designated devices. This data is subject to change without notice and revision of this document. For browser-based versions of this data sheet, refer to the left-hand navigation.

**PACKAGING INFORMATION**

Orderable Device	Status (1)	Package Type	Package Drawing	Pins	Package Qty	Eco Plan (2)	Lead finish/ Ball material (6)	MSL Peak Temp (3)	Op Temp (°C)	Device Marking (4/5)	Samples
TCA6416APWR	ACTIVE	TSSOP	PW	24	2000	RoHS & Green	NIPDAU	Level-1-260C-UNLIM	-40 to 85	PH416A	<a href="#">Samples</a>
TCA6416ARTWR	ACTIVE	WQFN	RTW	24	3000	RoHS & Green	NIPDAU	Level-2-260C-1 YEAR	-40 to 85	PH416A	<a href="#">Samples</a>

(1) The marketing status values are defined as follows:

**ACTIVE:** Product device recommended for new designs.

**LIFEBUY:** TI has announced that the device will be discontinued, and a lifetime-buy period is in effect.

**NRND:** Not recommended for new designs. Device is in production to support existing customers, but TI does not recommend using this part in a new design.

**PREVIEW:** Device has been announced but is not in production. Samples may or may not be available.

**OBSOLETE:** TI has discontinued the production of the device.

(2) **RoHS:** TI defines "RoHS" to mean semiconductor products that are compliant with the current EU RoHS requirements for all 10 RoHS substances, including the requirement that RoHS substance do not exceed 0.1% by weight in homogeneous materials. Where designed to be soldered at high temperatures, "RoHS" products are suitable for use in specified lead-free processes. TI may reference these types of products as "Pb-Free".

**RoHS Exempt:** TI defines "RoHS Exempt" to mean products that contain lead but are compliant with EU RoHS pursuant to a specific EU RoHS exemption.

**Green:** TI defines "Green" to mean the content of Chlorine (Cl) and Bromine (Br) based flame retardants meet JS709B low halogen requirements of <=1000ppm threshold. Antimony trioxide based flame retardants must also meet the <=1000ppm threshold requirement.

(3) MSL, Peak Temp. - The Moisture Sensitivity Level rating according to the JEDEC industry standard classifications, and peak solder temperature.

(4) There may be additional marking, which relates to the logo, the lot trace code information, or the environmental category on the device.

(5) Multiple Device Markings will be inside parentheses. Only one Device Marking contained in parentheses and separated by a "~" will appear on a device. If a line is indented then it is a continuation of the previous line and the two combined represent the entire Device Marking for that device.

(6) Lead finish/Ball material - Orderable Devices may have multiple material finish options. Finish options are separated by a vertical ruled line. Lead finish/Ball material values may wrap to two lines if the finish value exceeds the maximum column width.

**Important Information and Disclaimer:**The information provided on this page represents TI's knowledge and belief as of the date that it is provided. TI bases its knowledge and belief on information provided by third parties, and makes no representation or warranty as to the accuracy of such information. Efforts are underway to better integrate information from third parties. TI has taken and continues to take reasonable steps to provide representative and accurate information but may not have conducted destructive testing or chemical analysis on incoming materials and chemicals. TI and TI suppliers consider certain information to be proprietary, and thus CAS numbers and other limited information may not be available for release.

In no event shall TI's liability arising out of such information exceed the total purchase price of the TI part(s) at issue in this document sold by TI to Customer on an annual basis.



**TAPE AND REEL INFORMATION**

**QUADRANT ASSIGNMENTS FOR PIN 1 ORIENTATION IN TAPE**

\*All dimensions are nominal

Device	Package Type	Package Drawing	Pins	SPQ	Reel Diameter (mm)	Reel Width W1 (mm)	A0 (mm)	B0 (mm)	K0 (mm)	P1 (mm)	W (mm)	Pin1 Quadrant
TCA6416APWR	TSSOP	PW	24	2000	330.0	16.4	6.95	8.3	1.6	8.0	16.0	Q1
TCA6416ARTWR	WQFN	RTW	24	3000	330.0	12.4	4.25	4.25	1.15	8.0	12.0	Q2
TCA6416ARTWR	WQFN	RTW	24	3000	330.0	12.4	4.25	4.25	1.15	8.0	12.0	Q2

## TAPE AND REEL BOX DIMENSIONS



\*All dimensions are nominal

Device	Package Type	Package Drawing	Pins	SPQ	Length (mm)	Width (mm)	Height (mm)
TCA6416APWR	TSSOP	PW	24	2000	356.0	356.0	35.0
TCA6416ARTWR	WQFN	RTW	24	3000	356.0	356.0	35.0
TCA6416ARTWR	WQFN	RTW	24	3000	367.0	367.0	35.0

PW0024A

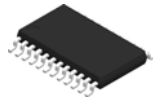

# PACKAGE OUTLINE

TSSOP - 1.2 mm max height

SMALL OUTLINE PACKAGE

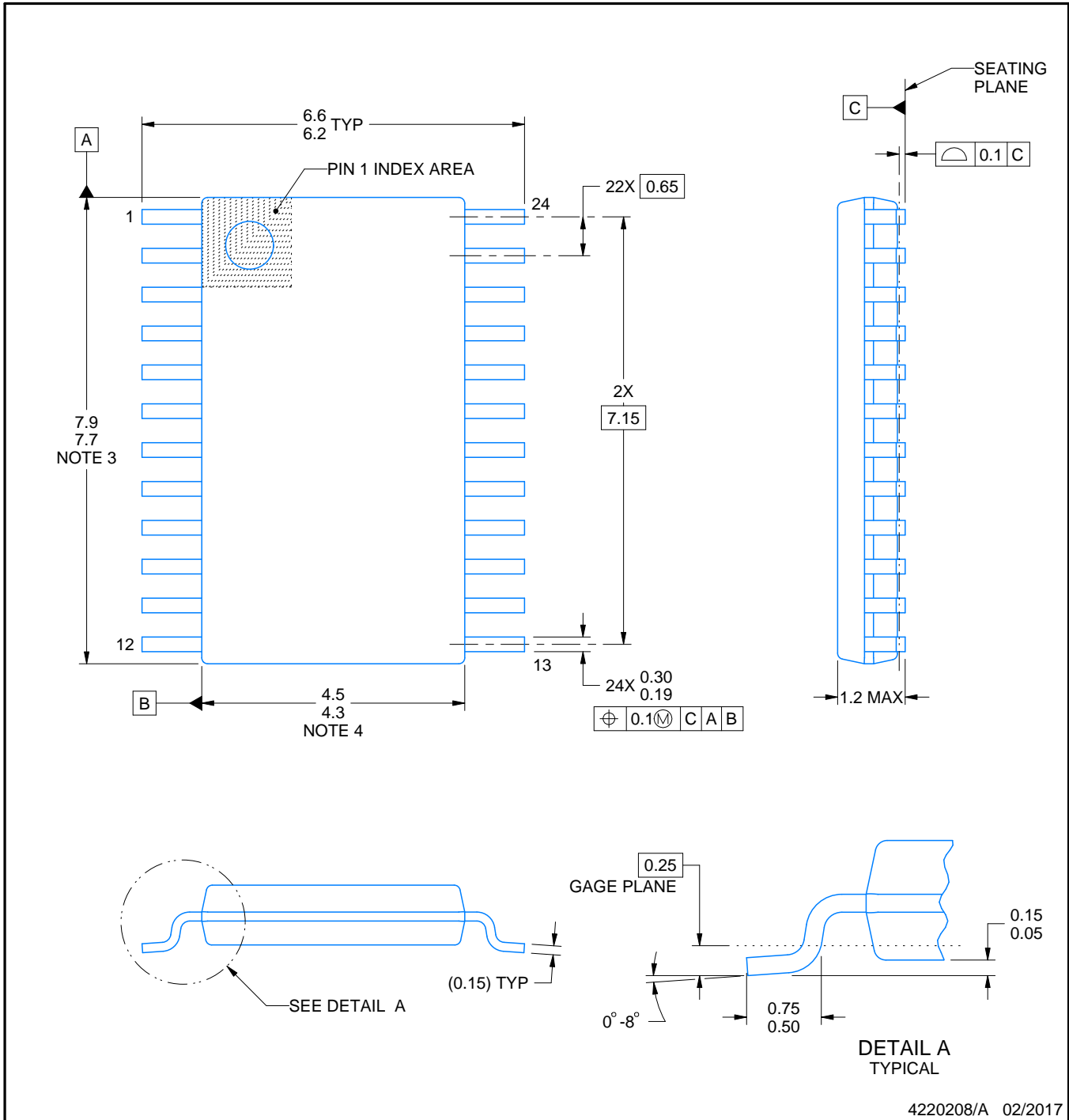

4220208/A 02/2017

NOTES:

1. All linear dimensions are in millimeters. Any dimensions in parenthesis are for reference only. Dimensioning and tolerancing per ASME Y14.5M.
2. This drawing is subject to change without notice.
3. This dimension does not include mold flash, protrusions, or gate burrs. Mold flash, protrusions, or gate burrs shall not exceed 0.15 mm per side.
4. This dimension does not include interlead flash. Interlead flash shall not exceed 0.25 mm per side.
5. Reference JEDEC registration MO-153.

# EXAMPLE BOARD LAYOUT

PW0024A

TSSOP - 1.2 mm max height

SMALL OUTLINE PACKAGE

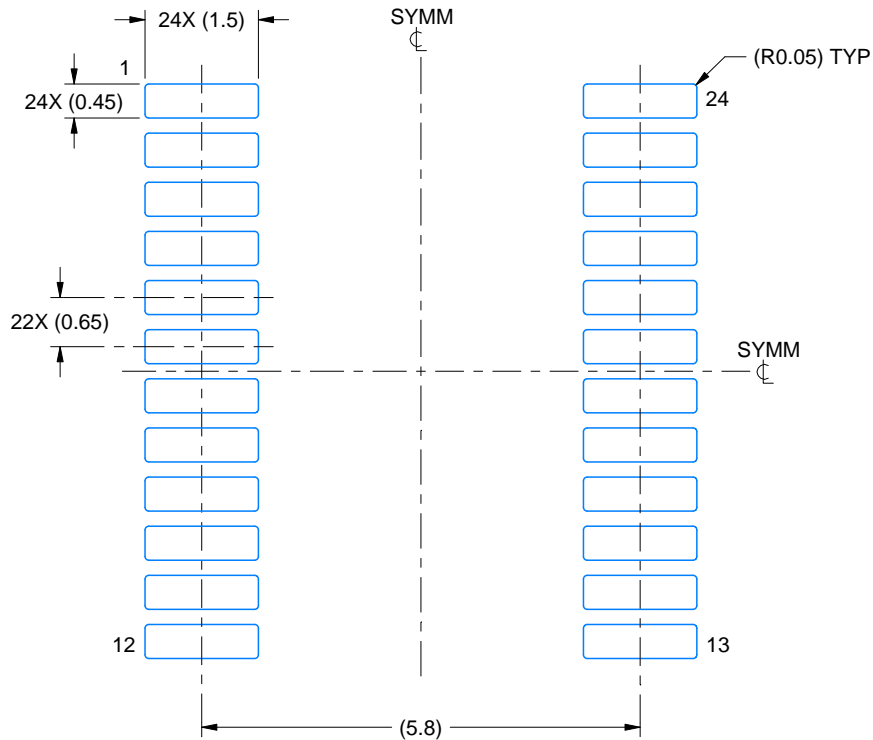

LAND PATTERN EXAMPLE  
EXPOSED METAL SHOWN  
SCALE: 10X

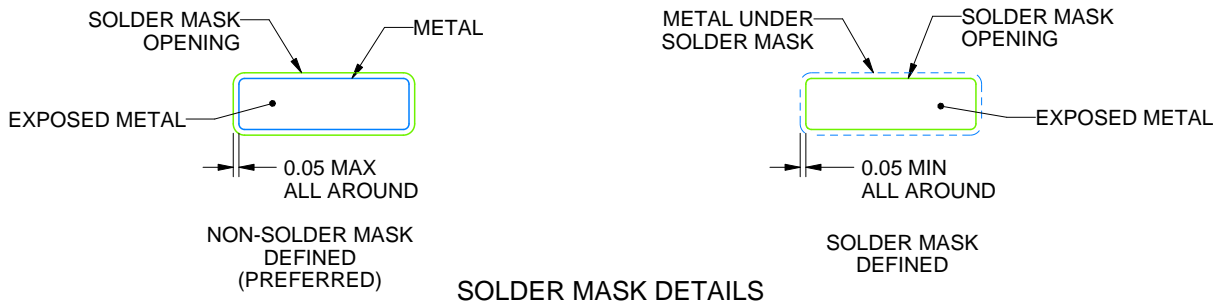

SOLDER MASK DETAILS

4220208/A 02/2017

NOTES: (continued)

- 6. Publication IPC-7351 may have alternate designs.
- 7. Solder mask tolerances between and around signal pads can vary based on board fabrication site.

# EXAMPLE STENCIL DESIGN

PW0024A

TSSOP - 1.2 mm max height

SMALL OUTLINE PACKAGE

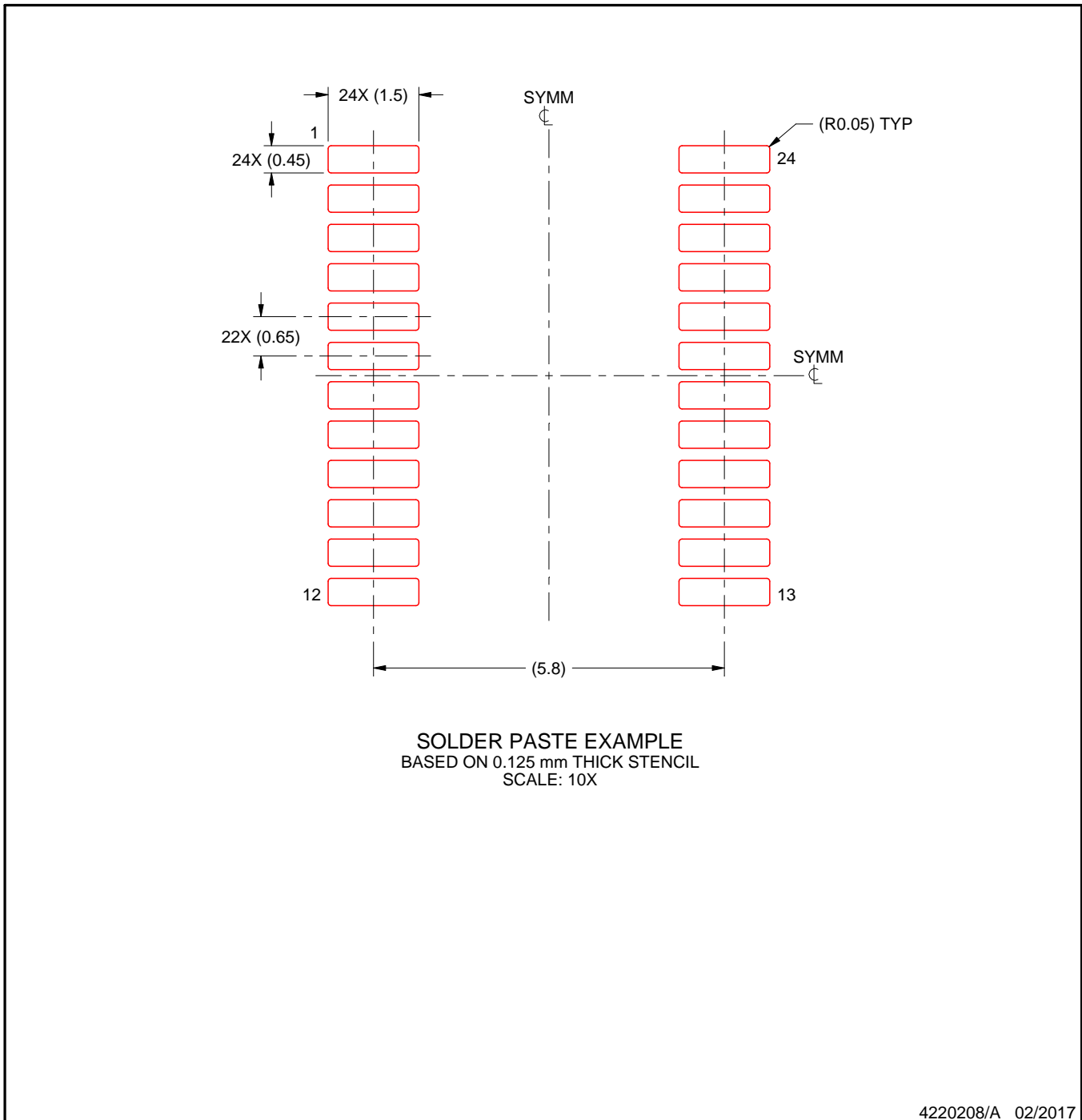

NOTES: (continued)

8. Laser cutting apertures with trapezoidal walls and rounded corners may offer better paste release. IPC-7525 may have alternate design recommendations.
9. Board assembly site may have different recommendations for stencil design.

## GENERIC PACKAGE VIEW

**RTW 24**

**WQFN - 0.8 mm max height**

4 x 4, 0.5 mm pitch

PLASTIC QUAD FLATPACK - NO LEAD

This image is a representation of the package family, actual package may vary.  
Refer to the product data sheet for package details.

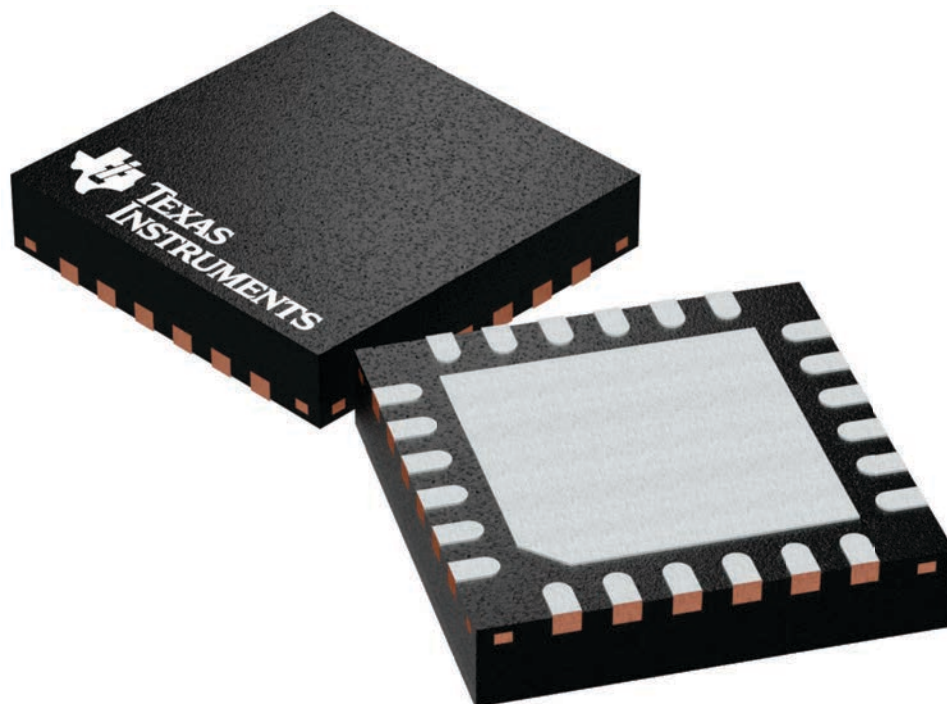

4224801/A

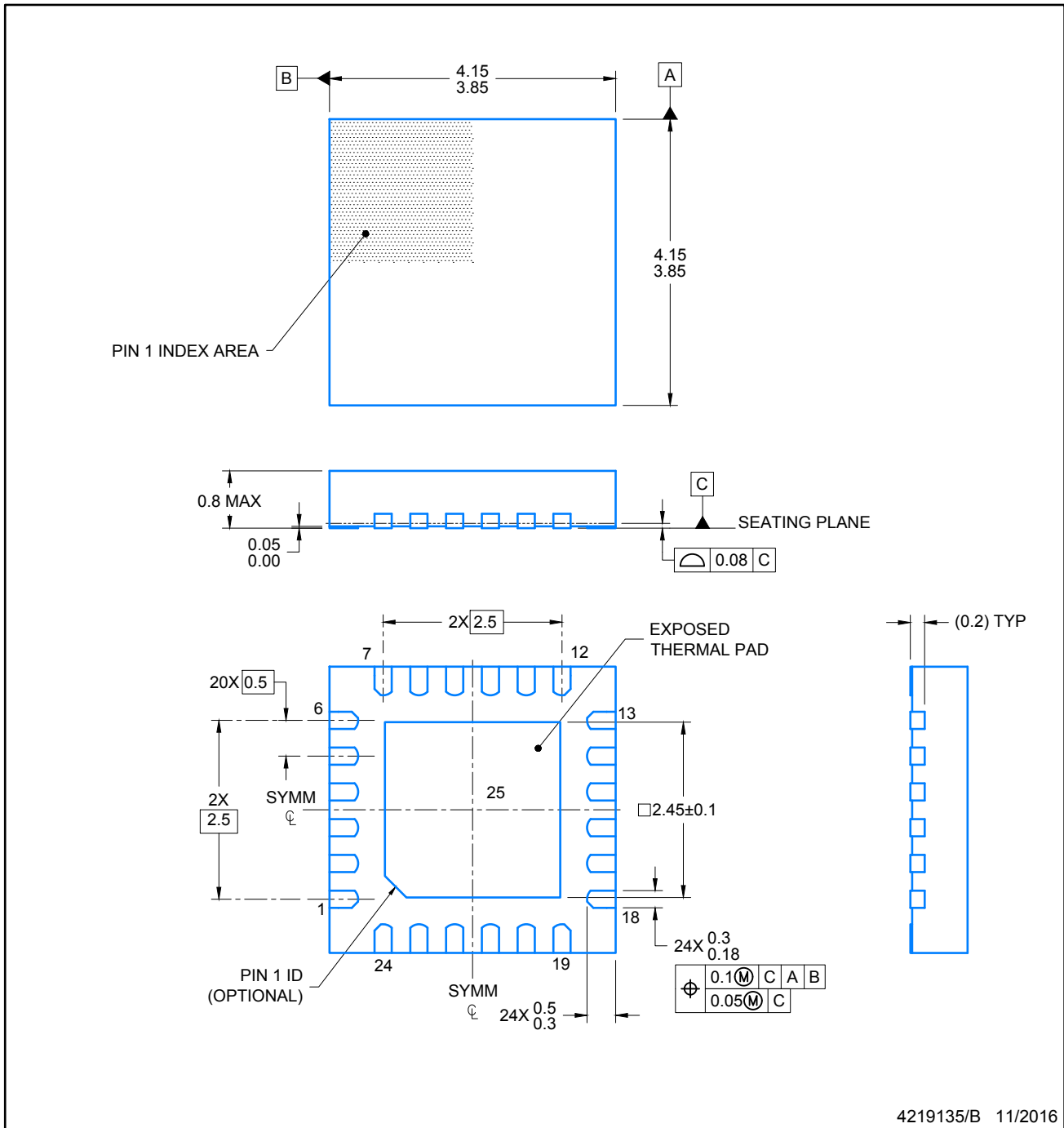

NOTES:

1. All linear dimensions are in millimeters. Any dimensions in parenthesis are for reference only. Dimensioning and tolerancing per ASME Y14.5M.
2. This drawing is subject to change without notice.

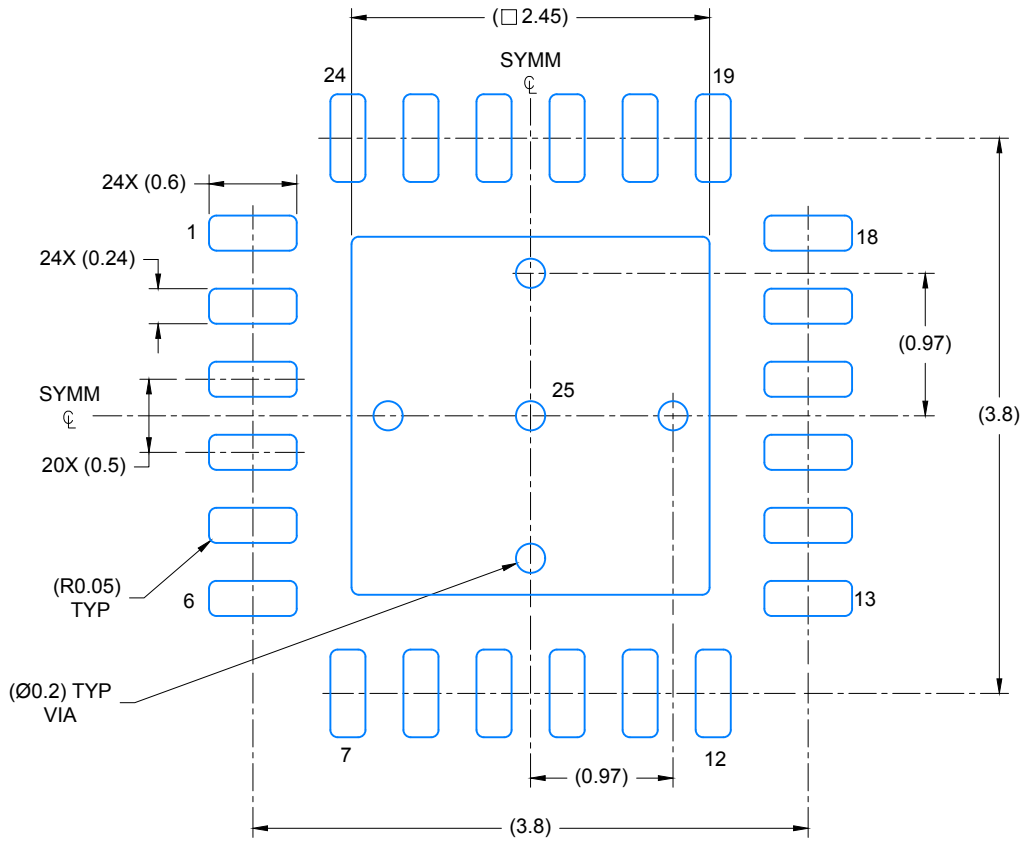

LAND PATTERN EXAMPLE  
SCALE: 20X

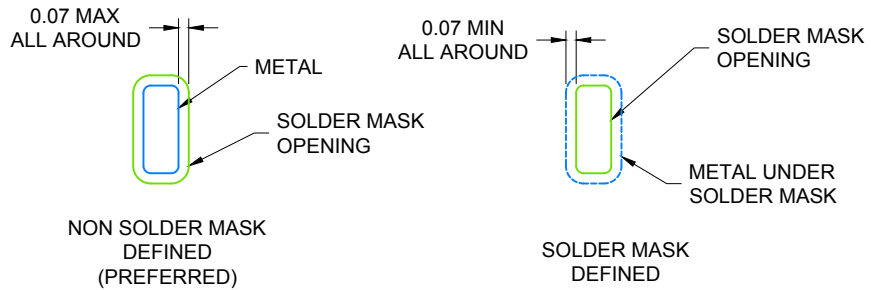

SOLDER MASK DETAILS

4219135/B 11/2016

NOTES: (continued)

- 3. For more information, see Texas Instruments literature number SLUA271 ([www.ti.com/lit/sluea271](http://www.ti.com/lit/sluea271)).

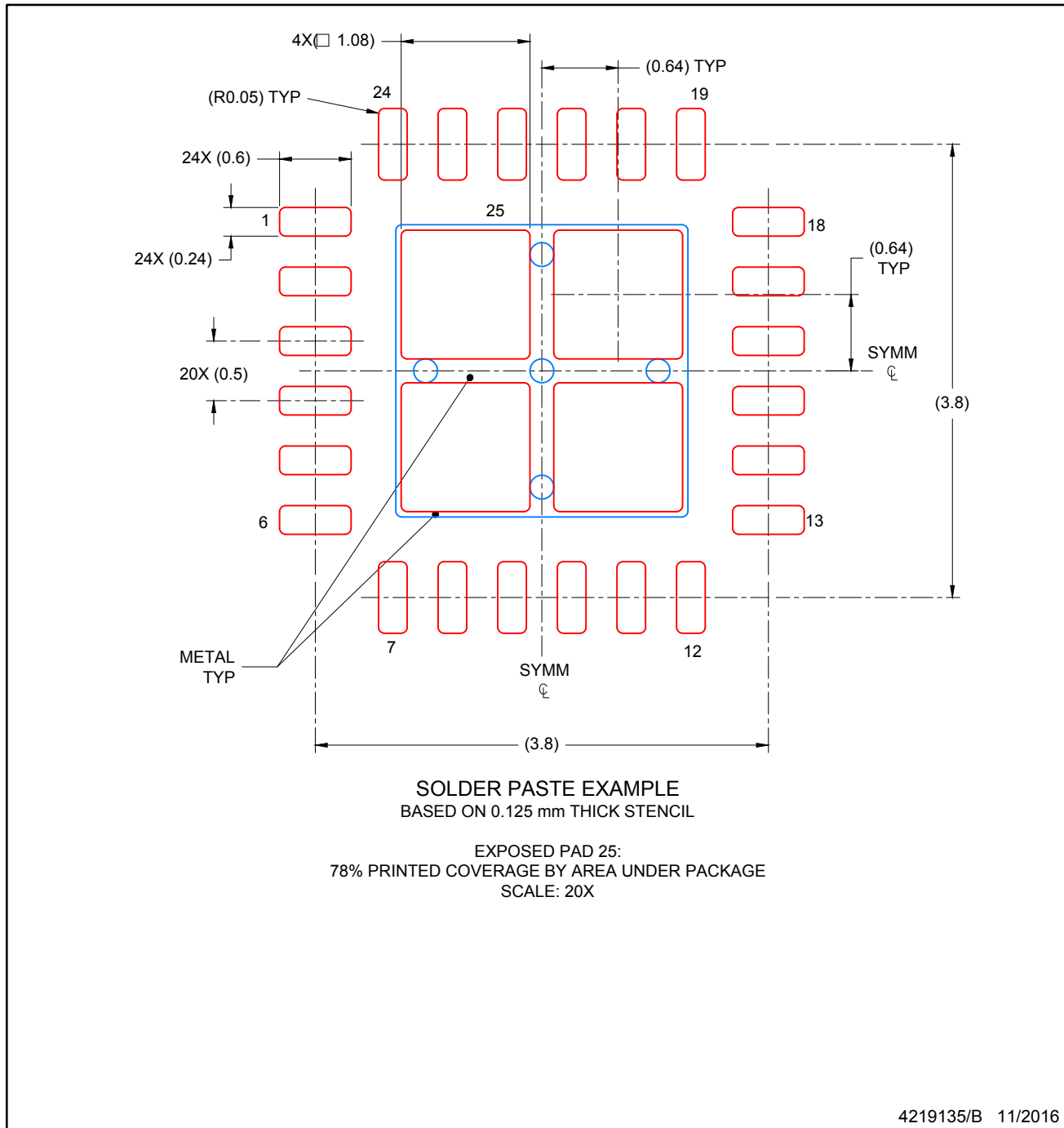

NOTES: (continued)

4. Laser cutting apertures with trapezoidal walls and rounded corners may offer better paste release. IPC-7525 may have alternate design recommendations.

## IMPORTANT NOTICE AND DISCLAIMER

TI PROVIDES TECHNICAL AND RELIABILITY DATA (INCLUDING DATA SHEETS), DESIGN RESOURCES (INCLUDING REFERENCE DESIGNS), APPLICATION OR OTHER DESIGN ADVICE, WEB TOOLS, SAFETY INFORMATION, AND OTHER RESOURCES "AS IS" AND WITH ALL FAULTS, AND DISCLAIMS ALL WARRANTIES, EXPRESS AND IMPLIED, INCLUDING WITHOUT LIMITATION ANY IMPLIED WARRANTIES OF MERCHANTABILITY, FITNESS FOR A PARTICULAR PURPOSE OR NON-INFRINGEMENT OF THIRD PARTY INTELLECTUAL PROPERTY RIGHTS.

These resources are intended for skilled developers designing with TI products. You are solely responsible for (1) selecting the appropriate TI products for your application, (2) designing, validating and testing your application, and (3) ensuring your application meets applicable standards, and any other safety, security, regulatory or other requirements.

These resources are subject to change without notice. TI grants you permission to use these resources only for development of an application that uses the TI products described in the resource. Other reproduction and display of these resources is prohibited. No license is granted to any other TI intellectual property right or to any third party intellectual property right. TI disclaims responsibility for, and you will fully indemnify TI and its representatives against, any claims, damages, costs, losses, and liabilities arising out of your use of these resources.

TI's products are provided subject to [TI's Terms of Sale](#) or other applicable terms available either on [ti.com](https://www.ti.com) or provided in conjunction with such TI products. TI's provision of these resources does not expand or otherwise alter TI's applicable warranties or warranty disclaimers for TI products.

TI objects to and rejects any additional or different terms you may have proposed.

Mailing Address: Texas Instruments, Post Office Box 655303, Dallas, Texas 75265  
Copyright © 2023, Texas Instruments Incorporated

## Looking for pricing, stock, or lifecycle information?

Click below to explore more details on WIN SOURCE:

 [View TCA6416ARTWR on WIN SOURCE](#)

 [Texas Instruments](#) Information

## Optimize Your Supply Chain with WIN SOURCE Solutions

-  Global Sourcing Solution
-  Obsolete Management
-  Cost Control Management
-  Shortage Management
-  Alternative Solution
-  Excess Inventory Management