

TOSHIBA CMOS Digital Integrated Circuit Silicon Monolithic

TC7S66F, TC7S66FU

Bilateral Switch

The TC7S66 is a high Speed C²MOS Bilateral Switch fabricated with silicon gate C²MOS technology.

It consists of a high speed switch capable of controlling either digital or analog signals while maintaining the C²MOS low power dissipation.

Control input (C) is provided to control the switch.

The switch turns ON while the C input is high, and the switch turns OFF while low.

Input is equipped with protection circuits against static discharge or transient excess voltage.

Features

- High speed: $t_{pd} = 7 \text{ ns (typ.) @} V_{CC} = 5 \text{ V}$
- Low power dissipation: $I_{CC} = 1 \mu\text{A (max) @} T_a = 25^\circ\text{C}$
- High noise immunity: $V_{NIH} = V_{NIL} = 28\% V_{CC} \text{ (min)}$
- Low ON resistance: $R_{ON} = 100 \Omega \text{ (typ.) @} V_{CC} = 9 \text{ V}$
- Low T.H.D: $\text{THD} = 0.05\% \text{ (typ.) @} V_{CC} = 5 \text{ V}$
- Pin and function compatible with TC4S66F

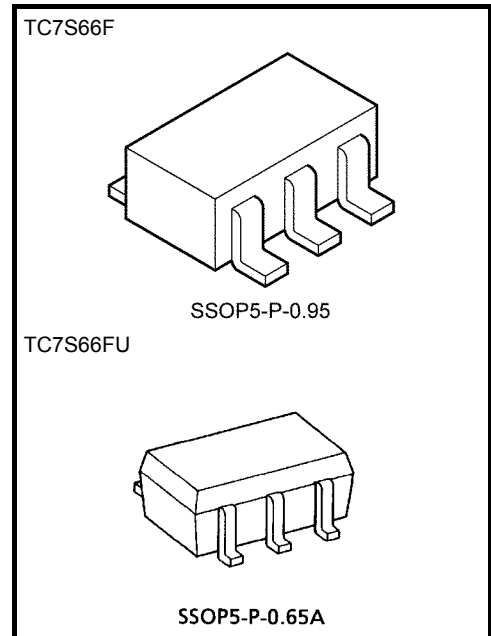

Weight
 SSOP5-P-0.95 : 0.016 g (typ.)
 SSOP5-P-0.65A : 0.006 g (typ.)

Absolute Maximum Ratings (Ta = 25°C)

Characteristics	Symbol	Rating	Unit
DC Supply voltage	V_{CC}	-0.5 to 13	V
Control input voltage	V_{IN}	-0.5 to $V_{CC} + 0.5$	V
Switch I/O voltage	$V_{I/O}$	-0.5 to $V_{CC} + 0.5$	V
Control diode current	I_{CK}	± 20	mA
I/O diode current	$I_{I/OK}$	± 20	mA
Through I/O current	I_T	± 12.5	mA
DC V_{CC} /ground current	I_{CC}	± 25	mA
Power dissipation	P_D	200	mW
Storage temperature range	T_{stg}	-65 to 150	°C
Lead temperature (10 s)	T_L	260	°C

Note: Using continuously under heavy loads (e.g. the application of high temperature/current/voltage and the significant change in temperature, etc.) may cause this product to decrease in the reliability significantly even if the operating conditions (i.e. operating temperature/current/voltage, etc.) are within the absolute maximum ratings and the operating ranges.

Please design the appropriate reliability upon reviewing the Toshiba Semiconductor Reliability Handbook ("Handling Precautions"/"Derating Concept and Methods") and individual reliability data (i.e. reliability test report and estimated failure rate, etc).

Start of commercial production
 1991-06

Marking

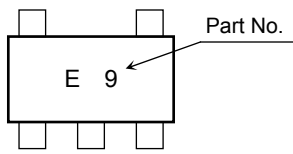

Pin Configuration (top view)

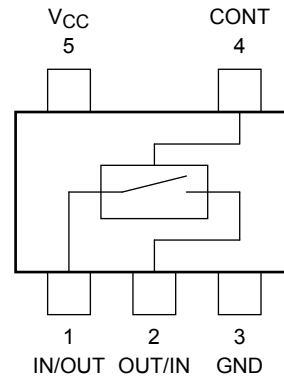

Logic Diagram

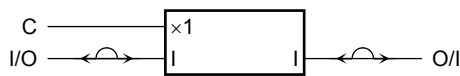

Truth Table

Control	Switch Function
H	ON
L	OFF

Operating Ranges

Characteristics	Symbol	Rating	Unit
Supply voltage	V_{CC}	2 to 12	V
Control input voltage	V_{IN}	0 to V_{CC}	V
Switch I/O voltage	$V_{I/O}$	0 to V_{CC}	V
Operating temperature range	T_{opr}	-40 to 85	°C
Input rise and fall time	t_r, t_f	0 to 1000 ($V_{CC} = 2.0$ V)	ns
		0 to 500 ($V_{CC} = 4.5$ V)	
		0 to 400 ($V_{CC} = 6.0$ V)	
		0 to 250 ($V_{CC} = 10.0$ V)	

Electrical Characteristics

DC Electrical Characteristics

Characteristics		Symbol	Test Condition	V _{CC} (V)	Ta = 25°C			Ta = -40 to 85°C		Unit
					Min	Typ.	Max	Min	Max	
Control input voltage	High level	V _{IHC}	—	2.0	1.5	—	—	1.5	—	V
				4.5	3.15	—	—	3.15	—	
				9.0	6.3	—	—	6.3	—	
				12.0	8.4	—	—	8.4	—	
	Low level	V _{ILC}	—	2.0	—	—	0.5	—	0.5	
				4.5	—	—	1.35	—	1.35	
				9.0	—	—	2.7	—	2.7	
				12.0	—	—	3.6	—	3.6	
ON resistance	R _{ON}	V _{IN} = V _{IHC} V _{I/O} = V _{CC} to GND I _{I/O} ≤ 1 mA	4.5	—	192	340	—	400	Ω	
			9.0	—	110	170	—	200		
			12.0	—	90	160	—	180		
			V _{IN} = V _{IHC} V _{I/O} = V _{CC} or GND I _{I/O} ≤ 1 mA	2.0	—	320	—	—		—
				4.5	—	140	200	—		260
				9.0	—	100	150	—		190
		12.0	—	90	140	—	180			
		Input/output leakage current (switch off)	I _{OFF}	V _{OS} = V _{CC} or GND V _{IS} = GND or V _{CC} V _{IN} = V _{ILC}	12.0	—	—	±100		—
Switch input leakage current (switch on, output open)	I _{IZ}	V _{OS} = V _{CC} or GND V _{IN} = V _{IHC}	12.0	—	—	±100	—	±1000	nA	
Control input current	I _{IN}	V _{IN} = V _{CC} or GND	12.0	—	—	±100	—	±1000	nA	
Quiescent device current	I _{CC}	V _{IN} = V _{CC} or GND	6.0	—	—	1.0	—	10.0	μA	
			9.0	—	—	4.0	—	40.0		
			12.0	—	—	8.0	—	80.0		

AC Electrical Characteristics (C_L = 50 pF, input t_r = t_f = 6 ns)

Characteristics	Symbol	Test Condition	Ta = 25°C			Ta = -40 to 85°C		Unit	
			V _{CC} (V)	Min	Typ.	Max	Min		Max
Phase difference between input and output	φ _{I-O}	—	2.0	—	20	75	—	100	ns
			4.5	—	7	15	—	20	
			9.0	—	4	12	—	15	
			12.0	—	4	11	—	14	
Output enable time	t _{pZL} t _{pZH}	R _L = 1 kΩ	2.0	—	20	150	—	190	ns
			4.5	—	13	30	—	38	
			9.0	—	9	18	—	33	
			12.0	—	8	18	—	27	
Output disable time	t _{pLZ} t _{pHZ}	R _L = 1 kΩ	2.0	—	40	170	—	220	ns
			4.5	—	11	35	—	44	
			9.0	—	10	30	—	38	
			12.0	—	9	27	—	33	
Maximum control input frequency	—	R _L = 1 kΩ C _L = 15 pF V _{OUT} = 1/2 V _{CC}	2.0	—	30	—	—	—	MHz
			4.5	—	30	—	—	—	
			9.0	—	30	—	—	—	
			12.0	—	30	—	—	—	
Control input capacitance	C _{IN}	—	—	5	10	—	10	pF	
Switch terminal capacitance	C _{I/O}	—	—	6	—	—	—	pF	
Feedthrough capacitance	C _{IOS}	—	—	0.5	—	—	—	pF	
Power dissipation capacitance	C _{PD}	(Note)	—	15	—	—	—	pF	

Note: C_{PD} is defined as the value of the internal equivalent capacitance which is calculated from the operating current consumption without load.

Average operating current can be obtained by the equation:

$$I_{CC (opr)} = C_{PD} \cdot V_{CC} \cdot f_{IN} + I_{CC}$$

Analog Switch Characteristics (GND = 0 V, Ta = 25°C) (Note)

Characteristics	Symbol	Test Condition	V _{CC} (V)	Typ.	Unit
Total harmonic distortion (T.H.D)	—	f _{IN} = 1 kHz, V _{IN} = 4 V _{p-p} (V _{CC} = 4.5 V) R _L = 10 kΩ, V _{IN} = 8 V _{p-p} (V _{CC} = 9.0 V) C _L = 50 pF	4.5	0.05	%
			9.0	0.04	
Maximum propagation frequency (switch on)	f _{MAX}	Adjust f _{IN} voltage to obtain 0dBm at V _{OS} increase f _{IN} frequency until dB meter reads -3dB. R _L = 50 Ω, C _L = 10 pF f _{IN} = 1 MHz, Sine wave	4.5	200	MHz
			9.0	200	
Feedthrough (switch on)	—	V _{IN} is centered at V _{CC} /2 adjust input for 0dBm R _L = 600 Ω, C _L = 50 pF f _{IN} = 1 MHz, Sine wave	4.5	-60	dB
			9.0	-60	
Crosstalk (control switch)	—	R _L = 600 Ω, C _L = 50 pF f _{IN} = 1 MHz, Pulse (t _r = t _f = 6 ns)	4.5	60	mV
			9.0	100	

Note: These characteristics are determined by design of devices.

Package Dimensions

SSOP5-P-0.95

Unit : mm

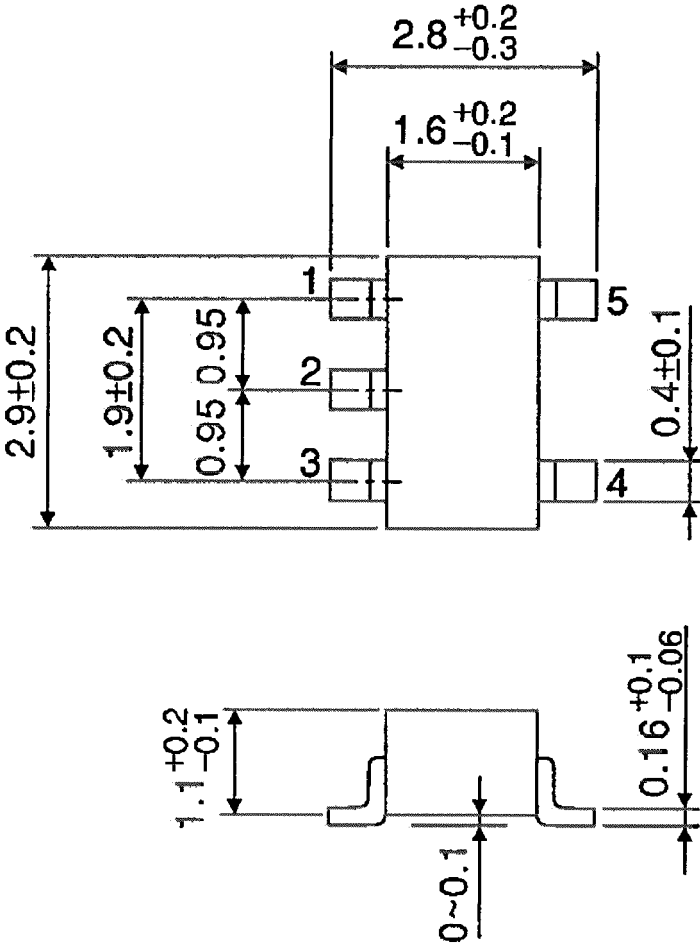

Weight: 0.016 g (typ.)

Package Dimensions

SSOP5-P-0.65A

Unit : mm

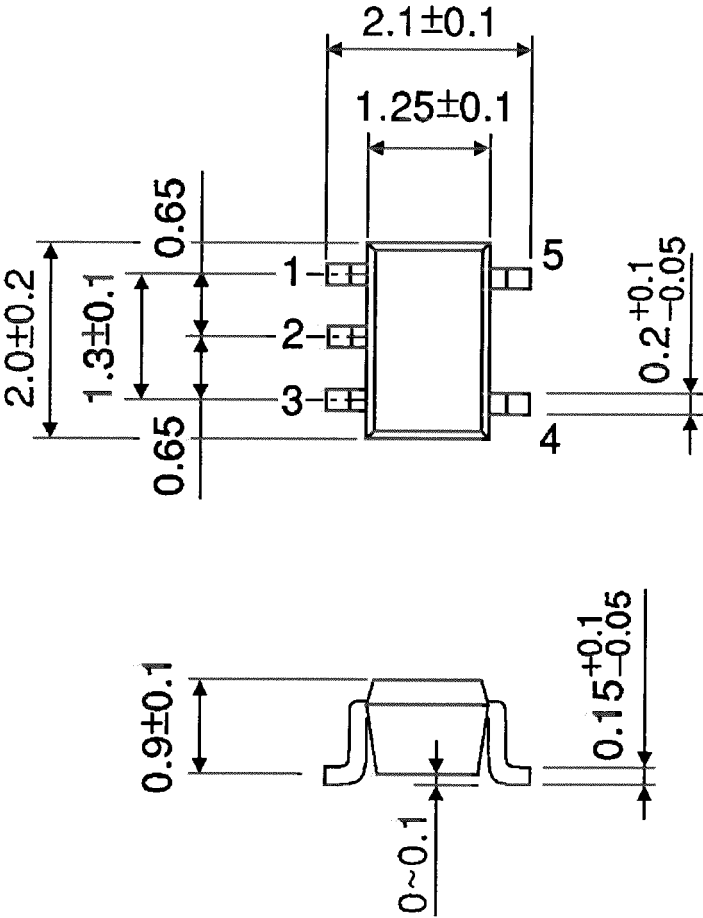

Weight: 0.006 g (typ.)

RESTRICTIONS ON PRODUCT USE

- Toshiba Corporation, and its subsidiaries and affiliates (collectively "TOSHIBA"), reserve the right to make changes to the information in this document, and related hardware, software and systems (collectively "Product") without notice.
- This document and any information herein may not be reproduced without prior written permission from TOSHIBA. Even with TOSHIBA's written permission, reproduction is permissible only if reproduction is without alteration/omission.
- Though TOSHIBA works continually to improve Product's quality and reliability, Product can malfunction or fail. Customers are responsible for complying with safety standards and for providing adequate designs and safeguards for their hardware, software and systems which minimize risk and avoid situations in which a malfunction or failure of Product could cause loss of human life, bodily injury or damage to property, including data loss or corruption. Before customers use the Product, create designs including the Product, or incorporate the Product into their own applications, customers must also refer to and comply with (a) the latest versions of all relevant TOSHIBA information, including without limitation, this document, the specifications, the data sheets and application notes for Product and the precautions and conditions set forth in the "TOSHIBA Semiconductor Reliability Handbook" and (b) the instructions for the application with which the Product will be used with or for. Customers are solely responsible for all aspects of their own product design or applications, including but not limited to (a) determining the appropriateness of the use of this Product in such design or applications; (b) evaluating and determining the applicability of any information contained in this document, or in charts, diagrams, programs, algorithms, sample application circuits, or any other referenced documents; and (c) validating all operating parameters for such designs and applications. **TOSHIBA ASSUMES NO LIABILITY FOR CUSTOMERS' PRODUCT DESIGN OR APPLICATIONS.**
- **PRODUCT IS NEITHER INTENDED NOR WARRANTED FOR USE IN EQUIPMENTS OR SYSTEMS THAT REQUIRE EXTRAORDINARILY HIGH LEVELS OF QUALITY AND/OR RELIABILITY, AND/OR A MALFUNCTION OR FAILURE OF WHICH MAY CAUSE LOSS OF HUMAN LIFE, BODILY INJURY, SERIOUS PROPERTY DAMAGE AND/OR SERIOUS PUBLIC IMPACT ("UNINTENDED USE").** Except for specific applications as expressly stated in this document, Unintended Use includes, without limitation, equipment used in nuclear facilities, equipment used in the aerospace industry, medical equipment, equipment used for automobiles, trains, ships and other transportation, traffic signaling equipment, equipment used to control combustions or explosions, safety devices, elevators and escalators, devices related to electric power, and equipment used in finance-related fields. **IF YOU USE PRODUCT FOR UNINTENDED USE, TOSHIBA ASSUMES NO LIABILITY FOR PRODUCT.** For details, please contact your TOSHIBA sales representative.
- Do not disassemble, analyze, reverse-engineer, alter, modify, translate or copy Product, whether in whole or in part.
- Product shall not be used for or incorporated into any products or systems whose manufacture, use, or sale is prohibited under any applicable laws or regulations.
- The information contained herein is presented only as guidance for Product use. No responsibility is assumed by TOSHIBA for any infringement of patents or any other intellectual property rights of third parties that may result from the use of Product. No license to any intellectual property right is granted by this document, whether express or implied, by estoppel or otherwise.
- **ABSENT A WRITTEN SIGNED AGREEMENT, EXCEPT AS PROVIDED IN THE RELEVANT TERMS AND CONDITIONS OF SALE FOR PRODUCT, AND TO THE MAXIMUM EXTENT ALLOWABLE BY LAW, TOSHIBA (1) ASSUMES NO LIABILITY WHATSOEVER, INCLUDING WITHOUT LIMITATION, INDIRECT, CONSEQUENTIAL, SPECIAL, OR INCIDENTAL DAMAGES OR LOSS, INCLUDING WITHOUT LIMITATION, LOSS OF PROFITS, LOSS OF OPPORTUNITIES, BUSINESS INTERRUPTION AND LOSS OF DATA, AND (2) DISCLAIMS ANY AND ALL EXPRESS OR IMPLIED WARRANTIES AND CONDITIONS RELATED TO SALE, USE OF PRODUCT, OR INFORMATION, INCLUDING WARRANTIES OR CONDITIONS OF MERCHANTABILITY, FITNESS FOR A PARTICULAR PURPOSE, ACCURACY OF INFORMATION, OR NONINFRINGEMENT.**
- Do not use or otherwise make available Product or related software or technology for any military purposes, including without limitation, for the design, development, use, stockpiling or manufacturing of nuclear, chemical, or biological weapons or missile technology products (mass destruction weapons). Product and related software and technology may be controlled under the applicable export laws and regulations including, without limitation, the Japanese Foreign Exchange and Foreign Trade Law and the U.S. Export Administration Regulations. Export and re-export of Product or related software or technology are strictly prohibited except in compliance with all applicable export laws and regulations.
- Please contact your TOSHIBA sales representative for details as to environmental matters such as the RoHS compatibility of Product. Please use Product in compliance with all applicable laws and regulations that regulate the inclusion or use of controlled substances, including without limitation, the EU RoHS Directive. **TOSHIBA ASSUMES NO LIABILITY FOR DAMAGES OR LOSSES OCCURRING AS A RESULT OF NONCOMPLIANCE WITH APPLICABLE LAWS AND REGULATIONS.**

Looking for pricing, stock, or lifecycle information?

Click below to explore more details on WIN SOURCE:

- [View TC7S66FU\(TE85L\) on WIN SOURCE](#)
- [Toshiba Semiconductor and Storage Information](#)

Optimize Your Supply Chain with WIN SOURCE Solutions

- ✓ Global Sourcing Solution
- ✓ Obsolete Management
- ✓ Cost Control Management
- ✓ Shortage Management
- ✓ Alternative Solution
- ✓ Excess Inventory Management