

TC74VHCT08AF, TC74VHCT08AFN, TC74VHCT08AFT, TC74VHCT08AFK

Quad 2-Input AND Gate

The TC74VHCT08A is an advanced high speed CMOS 2-INPUT AND GATE fabricated with silicon gate C²MOS technology.

It achieves the high speed operation similar to equivalent Bipolar Schottky TTL while maintaining the CMOS low power dissipation.

The input voltage are compatible with TTL output voltage.

This device may be used as a level converter for interfacing 3.3 V to 5 V system.

Input protection and output circuit ensure that 0 to 5.5 V can be applied to the input and output ^(Note) pins without regard to the supply voltage. These structure prevents device destruction due to mismatched supply and input/output voltages such as battery back up, hot board insertion, etc.

Note: $V_{CC} = 0 V$

Features

- High speed: $t_{pd} = 5.0 \text{ ns}$ (typ.) at $V_{CC} = 5 V$
- Low power dissipation: $I_{CC} = 2 \mu A$ (max) at $T_a = 25^\circ C$
- Compatible with TTL outputs: $V_{IL} = 0.8 V$ (max)
 $V_{IH} = 2.0 V$ (min)
- Power down protection is provided on all inputs and outputs.
- Balanced propagation delays: $t_{pLH} \approx t_{pHL}$
- Low noise: $V_{OLP} = 0.8 V$ (max)
- Pin and function compatible with the 74 series (74AC/HC/F/ALS/LS etc.) 08 type.

Weight	
SOP14-P-300-1.27A	: 0.18 g (typ.)
SOP14-P-300-1.27	: 0.18 g (typ.)
SOL14-P-150-1.27	: 0.12 g (typ.)
TSSOP14-P-0044-0.65A	: 0.06 g (typ.)
VSSOP14-P-0030-0.50	: 0.02 g (typ.)

Note: xxxFN (JEDEC SOP) is not available in Japan.

TC74VHCT08AF

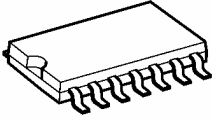

SOP14-P-300-1.27A

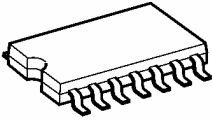

SOP14-P-300-1.27

TC74VHCT08AFN

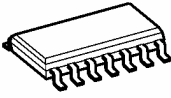

SOL14-P-150-1.27

TC74VHCT08AFT

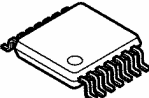

TSSOP14-P-0044-0.65A

TC74VHCT08AFK

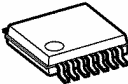

VSSOP14-P-0030-0.50

Pin Assignment

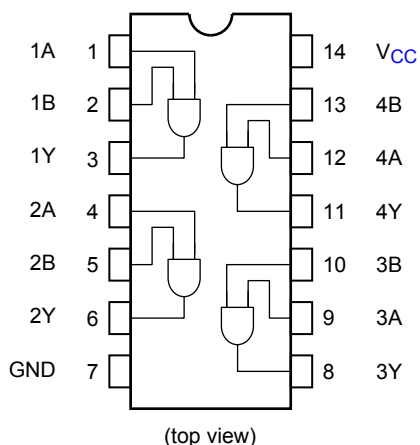

IEC Logic Symbol

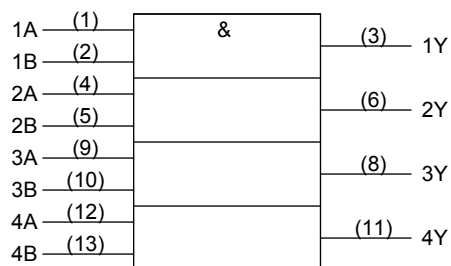

Truth Table

A	B	Y
L	L	L
L	H	L
H	L	L
H	H	H

Absolute Maximum Ratings (Note 1)

Characteristics	Symbol	Rating	Unit
Supply voltage range	V_{CC}	-0.5 to 7.0	V
DC input voltage	V_{IN}	-0.5 to 7.0	V
DC output voltage	V_{OUT}	-0.5 to 7.0 (Note 2)	V
		-0.5 to $V_{CC} + 0.5$ (Note 3)	
Input diode current	I_{IK}	-20	mA
Output diode current	I_{OK}	± 20 (Note 4)	mA
DC output current	I_{OUT}	± 25	mA
DC V_{CC} /ground current	I_{CC}	± 50	mA
Power dissipation	P_D	180	mW
Storage temperature	T_{stg}	-65 to 150	$^{\circ}C$

Note 1: Exceeding any of the absolute maximum ratings, even briefly, lead to deterioration in IC performance or even destruction.

Note 2: $V_{CC} = 0$ V

Note 3: High or low state. I_{OUT} absolute maximum rating must be observed.

Note 4: $V_{OUT} < GND$, $V_{OUT} > V_{CC}$

Recommended Operating Conditions (Note 1)

Characteristics	Symbol	Rating	Unit
Supply voltage	V_{CC}	4.5 to 5.5	V
Input voltage	V_{IN}	0 to 5.5	V
Output voltage	V_{OUT}	0 to 5.5 (Note 2)	V
		0 to V_{CC} (Note 3)	
Operating temperature	T_{opr}	-40 to 85	°C
Input rise and fall time	dt/dV	0 to 20	ns/V

Note 1: The recommended operating conditions are required to ensure the normal operation of the device.
Unused inputs must be tied to either VCC or GND.

Note 2: $V_{CC} = 0$ V

Note 3: High or low state.

Electrical Characteristics

DC Characteristics

Characteristics	Symbol	Test Condition	V_{CC} (V)	$T_a = 25^\circ\text{C}$			$T_a = -40$ to 85°C		Unit	
				Min	Typ.	Max	Min	Max		
High-level input voltage	V_{IH}	—	4.5 to 5.5	2.0	—	—	2.0	—	V	
Low-level input voltage	V_{IL}	—	4.5 to 5.5	—	—	0.8	—	0.8	V	
High-level output voltage	V_{OH}	$V_{IN} = V_{IH}$ or V_{IL}	$I_{OH} = -50 \mu\text{A}$	4.5	4.40	4.50	—	4.40	—	V
			$I_{OH} = -8 \text{ mA}$	4.5	3.94	—	—	3.80	—	
Low-level output voltage	V_{OL}	$V_{IN} = V_{IH}$ or V_{IL}	$I_{OL} = 50 \mu\text{A}$	4.5	—	0.0	0.1	—	0.1	V
			$I_{OL} = 8 \text{ mA}$	4.5	—	—	0.36	—	0.44	
Input leakage current	I_{IN}	$V_{IN} = 5.5 \text{ V}$ or GND	0 to 5.5	—	—	± 0.1	—	± 1.0	μA	
Quiescent supply current	I_{CC}	$V_{IN} = V_{CC}$ or GND	5.5	—	—	2.0	—	20.0	μA	
	I_{CCT}	Per input: $V_{IN} = 3.4 \text{ V}$ Other input: V_{CC} or GND	5.5	—	—	1.35	—	1.50	mA	
Output leakage current	I_{OPD}	$V_{OUT} = 5.5 \text{ V}$	0	—	—	0.5	—	5.0	μA	

AC Characteristics (input: $t_r = t_f = 3 \text{ ns}$)

Characteristics	Symbol	Test Condition		Ta = 25°C			Ta = -40 to 85°C		Unit	
		V _{CC} (V)	C _L (pF)	Min	Typ.	Max	Min	Max		
Propagation delay time	t _{pLH}	—	5.0 ± 0.5	15	—	5.0	6.9	1.0	8.0	ns
	t _{pHL}			50	—	5.5	7.9	1.0	9.0	
Input capacitance	C _{IN}	—		—	4	10	—	10	pF	
Power dissipation capacitance	C _{PD}	(Note)		—	18	—	—	—	pF	

Note: C_{PD} is defined as the value of the internal equivalent capacitance which is calculated from the operating current consumption without load.

Average operating current can be obtained by the equation:

$$I_{CC (opr)} = C_{PD} \cdot V_{CC} \cdot f_{IN} + I_{CC}/4 \text{ (per gate)}$$

Noise Characteristics (input: $t_r = t_f = 3 \text{ ns}$)

Characteristics	Symbol	Test Condition	Ta = 25°C			Unit
			V _{CC} (V)	Typ.	Max	
Quiet output maximum dynamic V _{OL}	V _{OLP}	C _L = 50 pF	5.0	0.4	0.8	V
Quiet output minimum dynamic V _{OL}	V _{OLV}	C _L = 50 pF	5.0	-0.4	-0.8	V
Minimum high level dynamic input voltage	V _{IHD}	C _L = 50 pF	5.0	—	2.0	V
Maximum low level dynamic input voltage	V _{ILD}	C _L = 50 pF	5.0	—	0.8	V

Package Dimensions

SOP14-P-300-1.27A

Unit: mm

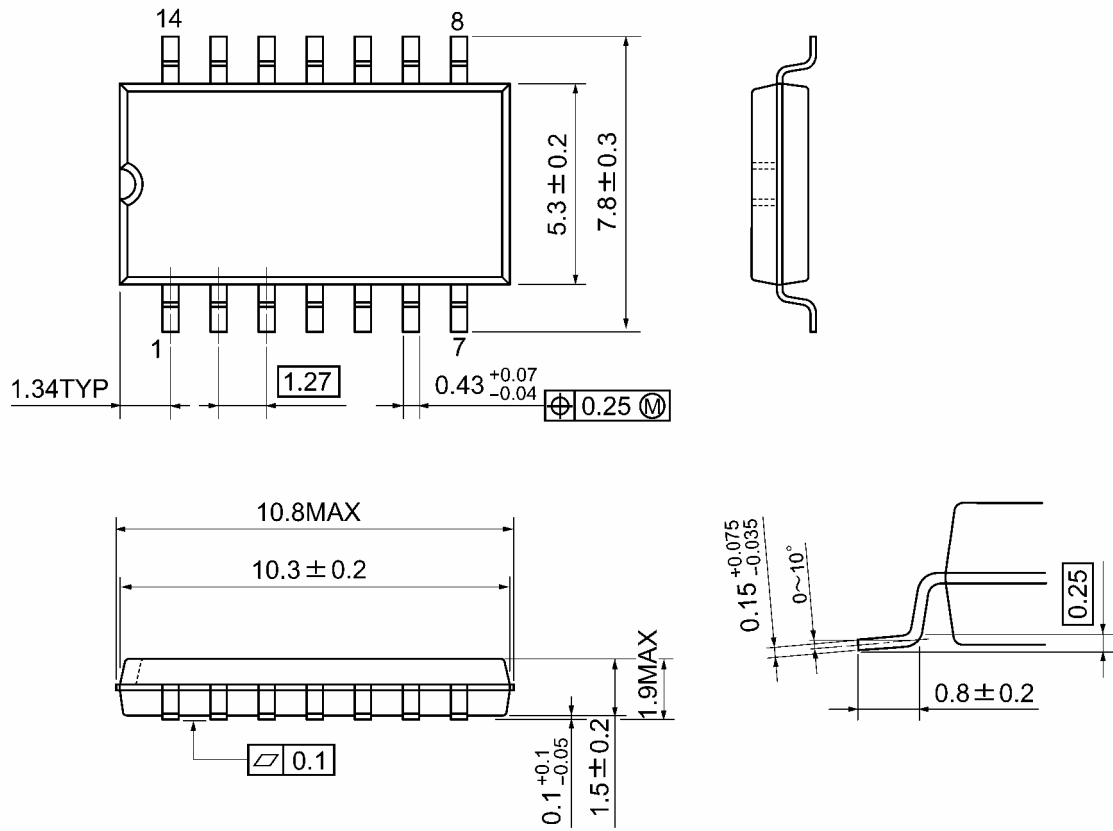

Weight: 0.18 g (typ.)

Package Dimensions

SOP14-P-300-1.27

Unit : mm

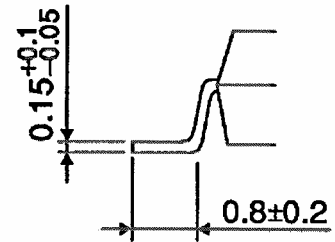
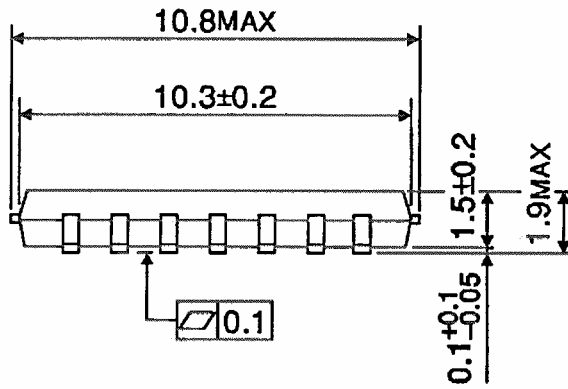
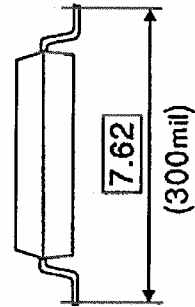
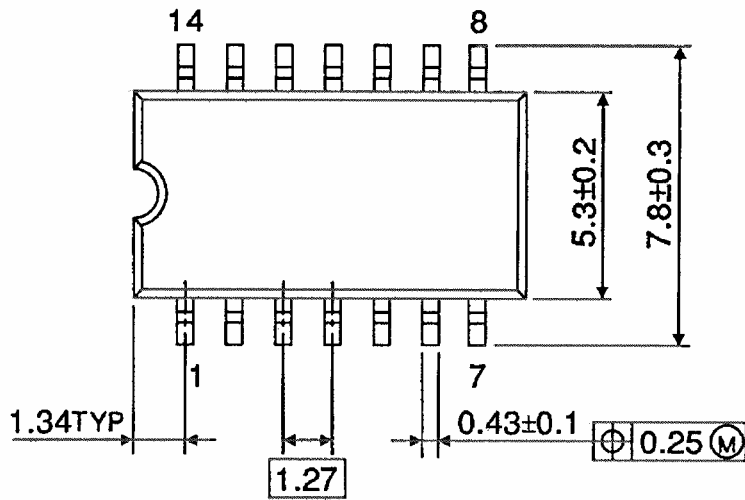

Weight: 0.18 g (typ.)

Package Dimensions (Note)

SOL14-P-150-1.27

Unit : mm

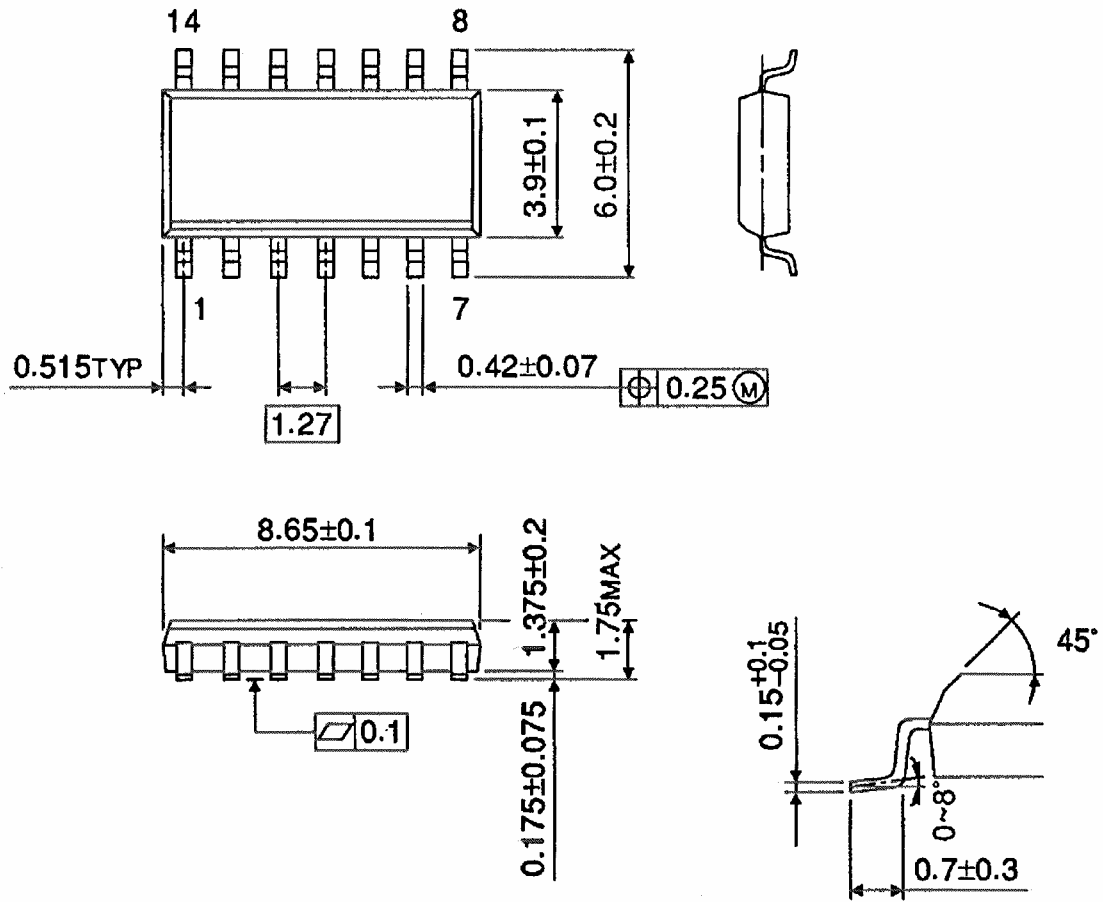

Note: This package is not available in Japan.

Weight: 0.12 g (typ.)

Package Dimensions

TSSOP14-P-0044-0.65A

Unit: mm

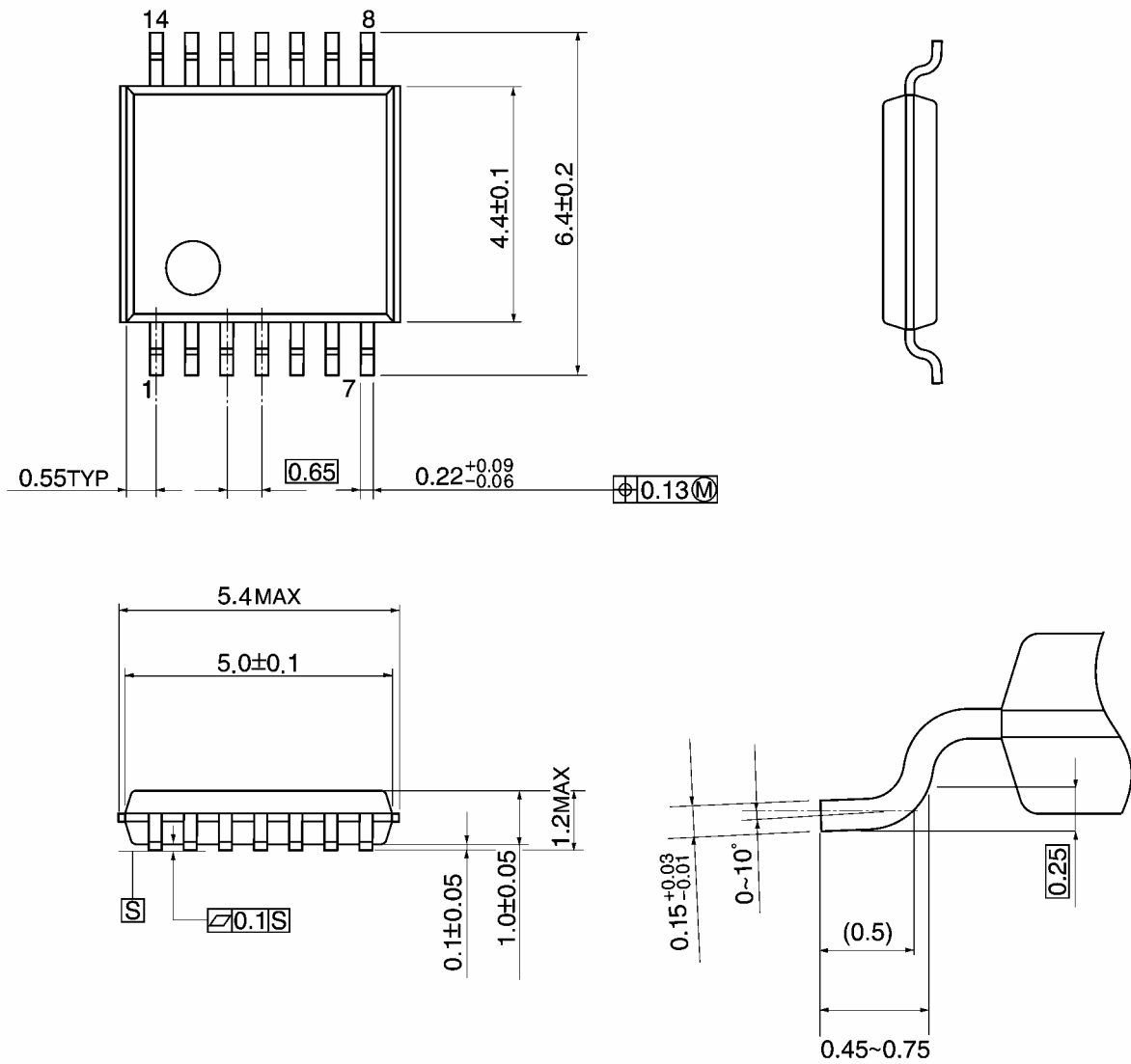

Weight: 0.06 g (typ.)

Package Dimensions

VSSOP14-P-0030-0.50

Unit: mm

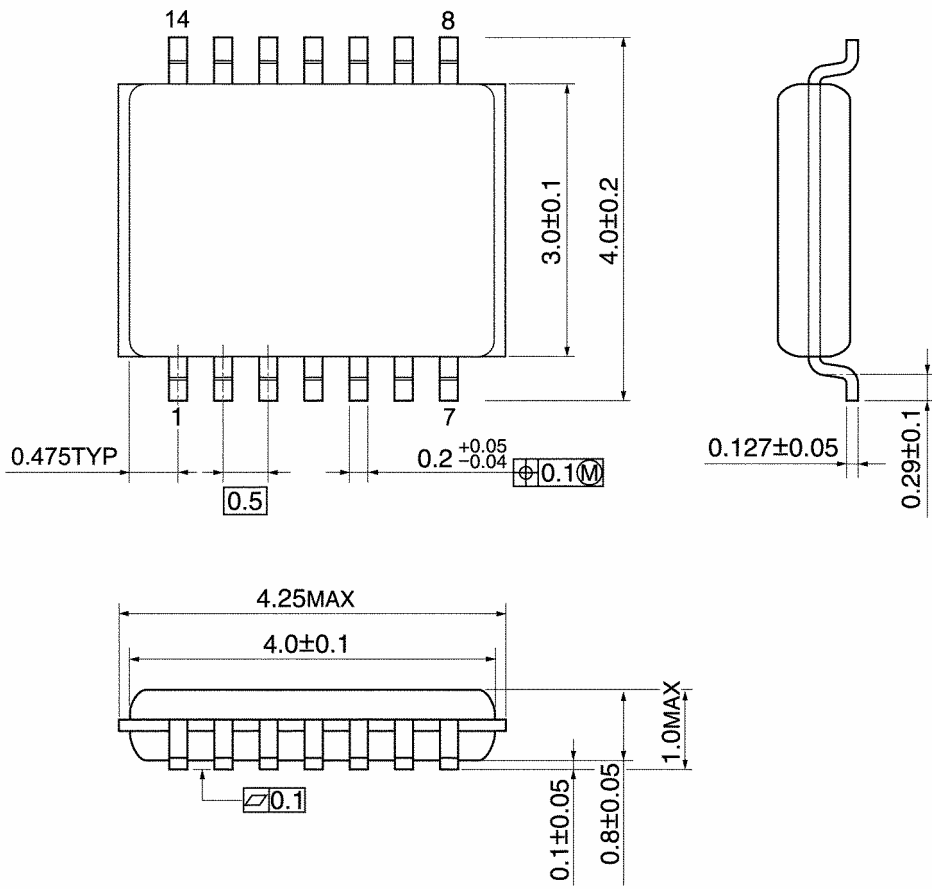

Weight: 0.02 g (typ.)

Note: Lead (Pb)-Free Packages**SOP14-P-300-1.27A SOL14-P-150-1.27 TSSOP14-P-0044-0.65A VSSOP14-P-0030-0.50****RESTRICTIONS ON PRODUCT USE**

20070701-EN

- The information contained herein is subject to change without notice.
- TOSHIBA is continually working to improve the quality and reliability of its products. Nevertheless, semiconductor devices in general can malfunction or fail due to their inherent electrical sensitivity and vulnerability to physical stress. It is the responsibility of the buyer, when utilizing TOSHIBA products, to comply with the standards of safety in making a safe design for the entire system, and to avoid situations in which a malfunction or failure of such TOSHIBA products could cause loss of human life, bodily injury or damage to property.
In developing your designs, please ensure that TOSHIBA products are used within specified operating ranges as set forth in the most recent TOSHIBA products specifications. Also, please keep in mind the precautions and conditions set forth in the "Handling Guide for Semiconductor Devices," or "TOSHIBA Semiconductor Reliability Handbook" etc.
- The TOSHIBA products listed in this document are intended for usage in general electronics applications (computer, personal equipment, office equipment, measuring equipment, industrial robotics, domestic appliances, etc.). These TOSHIBA products are neither intended nor warranted for usage in equipment that requires extraordinarily high quality and/or reliability or a malfunction or failure of which may cause loss of human life or bodily injury ("Unintended Usage"). Unintended Usage include atomic energy control instruments, airplane or spaceship instruments, transportation instruments, traffic signal instruments, combustion control instruments, medical instruments, all types of safety devices, etc.. Unintended Usage of TOSHIBA products listed in this document shall be made at the customer's own risk.
- The products described in this document shall not be used or embedded to any downstream products of which manufacture, use and/or sale are prohibited under any applicable laws and regulations.
- The information contained herein is presented only as a guide for the applications of our products. No responsibility is assumed by TOSHIBA for any infringements of patents or other rights of the third parties which may result from its use. No license is granted by implication or otherwise under any patents or other rights of TOSHIBA or the third parties.
- Please contact your sales representative for product-by-product details in this document regarding RoHS compatibility. Please use these products in this document in compliance with all applicable laws and regulations that regulate the inclusion or use of controlled substances. Toshiba assumes no liability for damage or losses occurring as a result of noncompliance with applicable laws and regulations.

Looking for pricing, stock, or lifecycle information?

Click below to explore more details on WIN SOURCE:

- [View TC74VHCT08AFT on WIN SOURCE](#)
- [Toshiba Semiconductor and Storage Information](#)

Optimize Your Supply Chain with WIN SOURCE Solutions

- ✓ Global Sourcing Solution
- ✓ Obsolete Management
- ✓ Cost Control Management
- ✓ Shortage Management
- ✓ Alternative Solution
- ✓ Excess Inventory Management