

1.2A Dual High-Speed MOSFET Drivers

Features:

- Low Cost
- Latch-Up Protected: Will Withstand 500 mA Reverse Output Current
- ESD Protected $\pm 2kV$
- High Peak Output Current: 1.2A
- Wide Operating Range:
 - 4.5V to 16V
- High Capacitive Load Drive Capability: 1000 pF in 38 nsec
- Low Delay Time: 75 nsec Max
- Logic Input Threshold Independent of Supply Voltage
- Output Voltage Swing to Within 25 mV of Ground or V_{DD}
- Low Output Impedance: 8Ω

Applications:

- Power MOSFET Drivers
- Switched Mode Power Supplies
- Pulse Transformer Drive
- Small Motor Controls
- Print Head Drive

Device Selection Table

Part Number	Package	Temp. Range
TC1426COA	8-Pin SOIC	0°C to +70°C
TC1426CPA	8-Pin PDIP	0°C to +70°C
TC1427COA	8-Pin SOIC	0°C to +70°C
TC1427CPA	8-Pin PDIP	0°C to +70°C
TC1428COA	8-Pin SOIC	0°C to +70°C
TC1428CPA	8-Pin PDIP	0°C to +70°C

Package Type

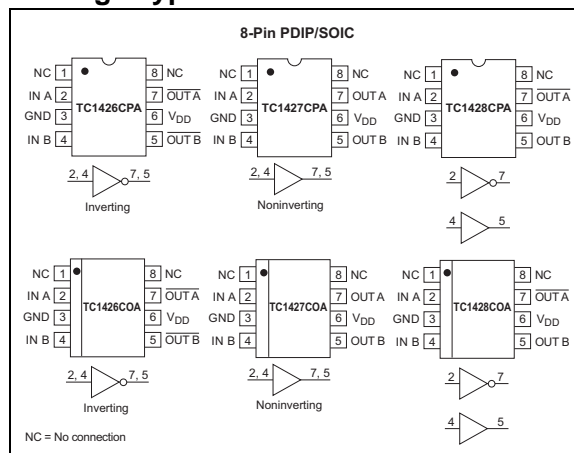

General Description:

The TC1426/TC1427/TC1428 are a family of 1.2A dual high-speed drivers. CMOS fabrication is used for low-power consumption and high efficiency.

These devices are fabricated using an epitaxial layer to effectively short out the intrinsic parasitic transistor responsible for CMOS latch-up. They incorporate a number of other design and process refinements to increase their long-term reliability.

The TC1426 is compatible with the bipolar DS0026, but only draws 1/5 of the quiescent current. The TC1426/TC1427/TC1428 are also compatible with the TC426/TC427/TC428, but with 1.2A peak output current rather than the 1.5A of the TC426/TC427/TC428 devices.

Other compatible drivers are the TC4426/TC4427/TC4428 and the TC4426A/TC4427A/TC4428A. The TC4426/TC4427/TC4428 have the added feature that the inputs can withstand negative voltage up to 5V with diode protection circuits. The TC4426A/TC4427A/TC4428A have matched input to output leading edge and falling edge delays, t_{D1} and t_{D2} , for processing short duration pulses in the 25 nanoseconds range. All of the above drivers are pin compatible.

The high-input impedance TC1426/TC1427/TC1428 drivers are CMOS/TTL input-compatible, do not require the speed-up needed by the bipolar devices, and can be directly driven by most PWM ICs.

This family of devices is available in inverting and non-inverting versions. Specifications have been optimized to achieve low-cost and high-performance devices, well-suited for the high-volume manufacturer.

TC1426/TC1427/TC1428

Functional Block Diagram

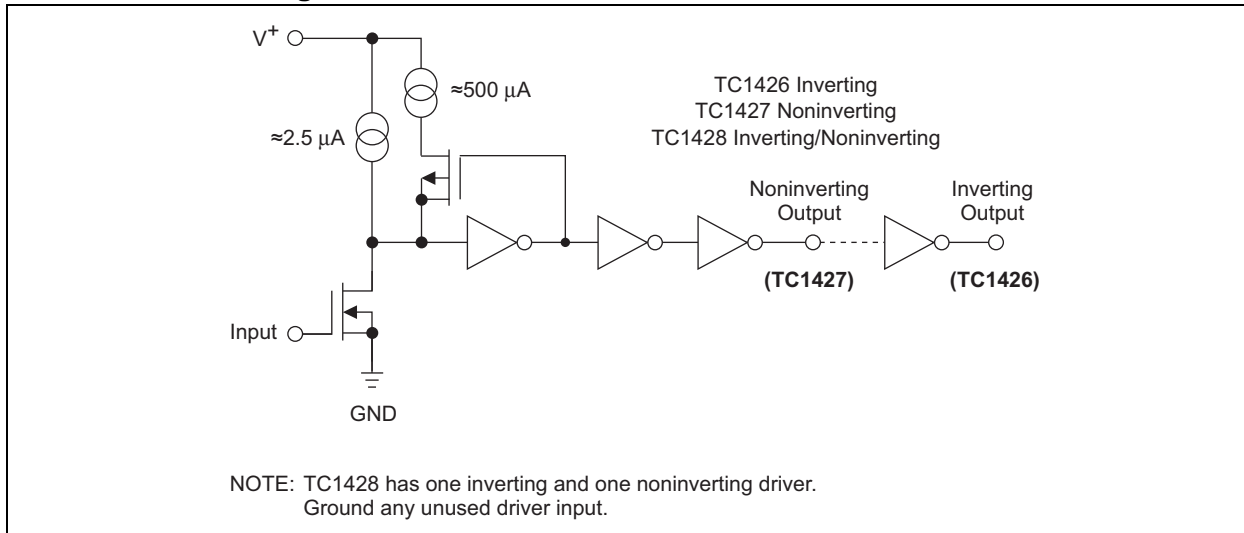

TC1426/TC1427/TC1428

1.0 ELECTRICAL CHARACTERISTICS

Absolute Maximum Ratings*

Supply Voltage	+18V
Input Voltage, Any Terminal	$V_{DD} + 0.3V$ to $GND - 0.3V$
Power Dissipation ($T_A \leq 70^\circ C$)	
PDIP	730 mW
SOIC	470 mW
Derating Factor	
PDIP	8 mW/ $^\circ C$
SOIC	4 mW/ $^\circ C$
Operating Temperature Range	
C Version	0 $^\circ C$ to +70 $^\circ C$
Storage Temperature Range	-65 $^\circ C$ to +150 $^\circ C$

*Stresses above those listed under "Absolute Maximum Ratings" may cause permanent damage to the device. These are stress ratings only and functional operation of the device at these or any other conditions above those indicated in the operation sections of the specifications is not implied. Exposure to Absolute Maximum Rating conditions for extended periods may affect device reliability.

TC1426/TC1427/TC1428 ELECTRICAL SPECIFICATIONS

Electrical Characteristics: $T_A = +25^\circ C$, with $4.5V \leq V_{DD} \leq 16V$, unless otherwise noted.						
Symbol	Parameter	Min	Typ	Max	Units	Test Conditions
Input						
V_{IH}	Logic 1, High Input Voltage	3	—	—	V	
V_{IL}	Logic 0, Low Input Voltage	—	—	0.8	V	
I_{IN}	Input Current	-1	—	1	μA	$0V \leq V_{IN} \leq V_{DD}$
Output						
V_{OH}	High Output Voltage	$V_{DD} - 0.025$	—	—	V	Figure 3-1, Figure 3-2
V_{OL}	Low Output Voltage	—	—	0.025	V	Figure 3-1, Figure 3-2
R_O	Output Resistance	—	12 8	18 12	Ω	$I_{OUT} = 10$ mA, $V_{DD} = 16V$
I_{PK}	Peak Output Current	—	1.2	—	A	
I_{REV}	Latch-Up Current Withstand Reverse Current	—	>500	—	mA	
Switching Time (Note 1)						
t_R	Rise Time	—	—	35	nsec	Figure 3-1, Figure 3-2
t_F	Fall Time	—	—	25	nsec	Figure 3-1, Figure 3-2
t_{D1}	Delay Time	—	—	75	nsec	Figure 3-1, Figure 3-2
t_{D2}	Delay Time	—	—	75	nsec	Figure 3-1, Figure 3-2
Power Supply						
I_S	Power Supply Current	—	—	9 0.5	mA	$V_{IN} = 3V$ (Both Inputs) $V_{IN} = 0V$ (Both Inputs)

Note 1: Switching times ensured by design.

TC1426/TC1427/TC1428

TC1426/TC1427/TC1428 ELECTRICAL SPECIFICATIONS (CONTINUED)

Electrical Characteristics: Over operating temperature range with $4.5V \leq V_{DD} \leq 16V$, unless otherwise noted.

Symbol	Parameter	Min	Typ	Max	Units	Test Conditions
Input						
V_{IH}	Logic 1, High Input Voltage	3	—	—	V	
V_{IL}	Logic 0, Low Input Voltage	—	—	0.8	V	
I_{IN}	Input Current	-10	—	10	μA	$0V \leq V_{IN} \leq V_{DD}$
Output						
V_{OH}	High Output Voltage	$V_{DD} - 0.025$	—	—	V	Figure 3-1, Figure 3-2
V_{OL}	Low Output Voltage	—	—	0.025	V	Figure 3-1, Figure 3-2
R_O	Output Resistance	—	15 10	23 18	Ω	$I_{OUT} = 10 \text{ mA}$, $V_{DD} = 16V$
I_{REV}	Latch-Up Current Withstand Reverse Current	—	>500	—	mA	
Switching Time (Note 1)						
t_R	Rise Time	—	—	60	nsec	Figure 3-1, Figure 3-2
t_F	Fall Time	—	—	40	nsec	Figure 3-1, Figure 3-2
t_{D1}	Delay Time	—	—	125	nsec	Figure 3-1, Figure 3-2
t_{D2}	Delay Time	—	—	125	nsec	Figure 3-1, Figure 3-2
Power Supply						
I_S	Power Supply Current	—	—	13 0.7	mA	$V_{IN} = 3V$ (Both Inputs) $V_{IN} = 0V$ (Both Inputs)

Note 1: Switching times ensured by design.

2.0 PIN DESCRIPTIONS

The descriptions of the pins are listed in Table 2-1.

TABLE 2-1: PIN FUNCTION TABLE

Pin No. (8-Pin PDIP, SOIC)	Symbol	Description
1	NC	No connection.
2	IN A	Control input A, TTL/CMOS compatible logic input.
3	GND	Ground.
4	IN B	Control input B, TTL/CMOS compatible logic input.
5	OUT B	Output B, CMOS totem-pole output.
6	V _{DD}	Supply input, 4.5V to 16V.
7	OUT A	Output A, CMOS totem-pole output.
8	NC	No connection.

TC1426/TC1427/TC1428

3.0 APPLICATIONS INFORMATION

3.1 SUPPLY BYPASSING

Large currents are required to charge and discharge capacitive loads quickly. For example, charging a 1000 pF load to 16V in 25 nsec requires a 0.8A current from the device's power supply.

To ensure low supply impedance over a wide frequency range, a parallel capacitor combination is recommended for supply bypassing. Low-inductance ceramic MLC capacitors with short lead lengths (<0.5-in.) should be used. A 1.0 μ F film capacitor in parallel with one or two 0.1 μ F ceramic MLC capacitors normally provides adequate bypassing.

3.2 GROUNDING

The TC1426 and TC1428 contain inverting drivers. Individual ground returns for the input and output circuits or a ground plane should be used. This will reduce negative feedback that causes degradation in switching speed characteristics.

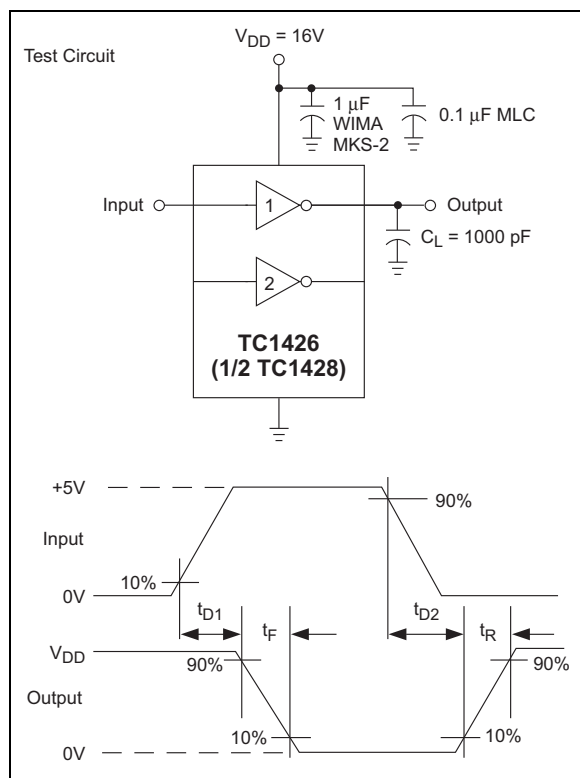

FIGURE 3-1: Inverting Driver Switching Time

3.3 INPUT STAGE

The input voltage level changes the no-load or quiescent supply current. The N-channel MOSFET input stage transistor drives a 2.5 mA current source load. With a logic '1' input, the maximum quiescent supply current is 9 mA. Logic '0' input level signals reduce quiescent current to 500 μ A maximum. **Unused driver inputs must be connected to V_{DD} or GND.** Minimum power dissipation occurs for logic '0' inputs for the TC1426/TC1427/TC1428.

The drivers are designed with 100 mV of hysteresis. This provides clean transitions and minimizes output stage current spiking when changing states. Input voltage thresholds are approximately 1.5V, making a logic '1' input any voltage greater than 1.5V up to V_{DD}. Input current is less than 1 μ A over this range.

The TC1426/TC1427/TC1428 may be directly driven by the TL494, SG1526/27, TC38C42, TC170 and similar switch-mode power supply integrated circuits.

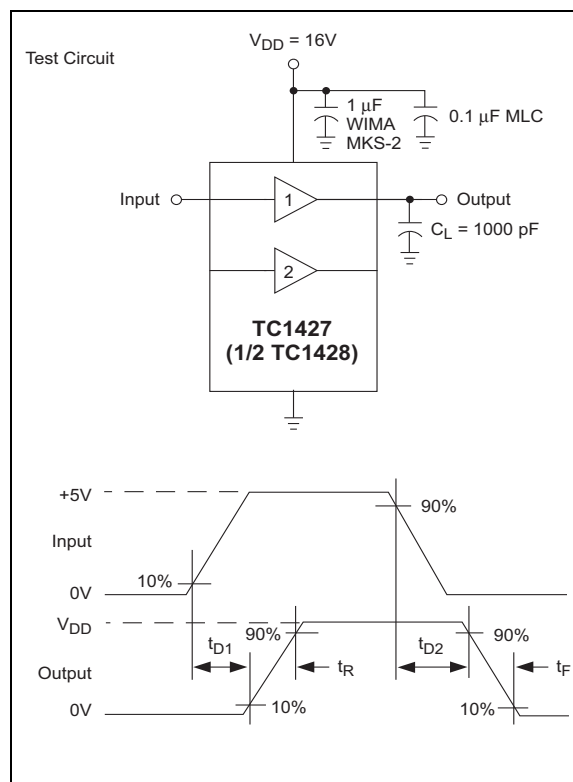
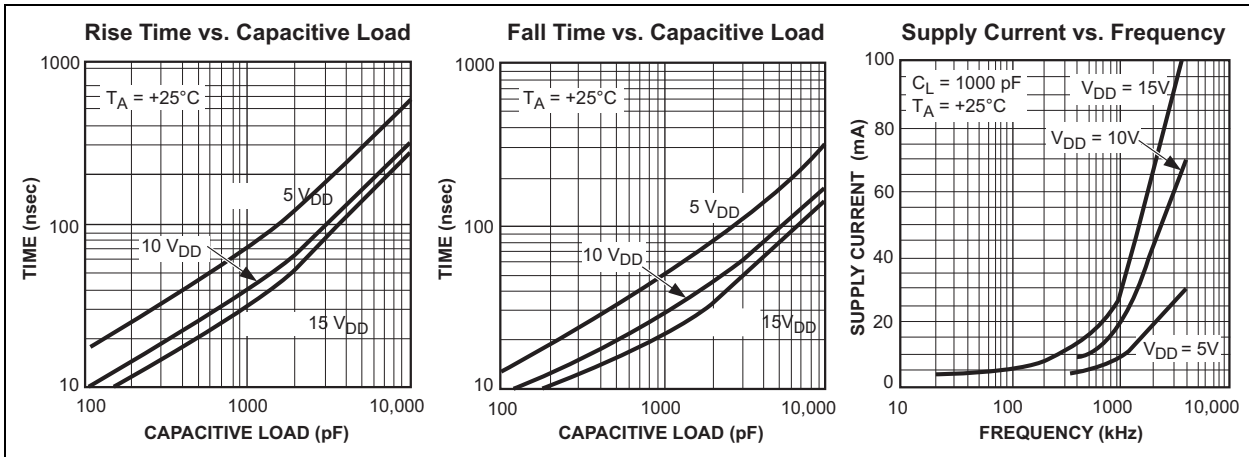
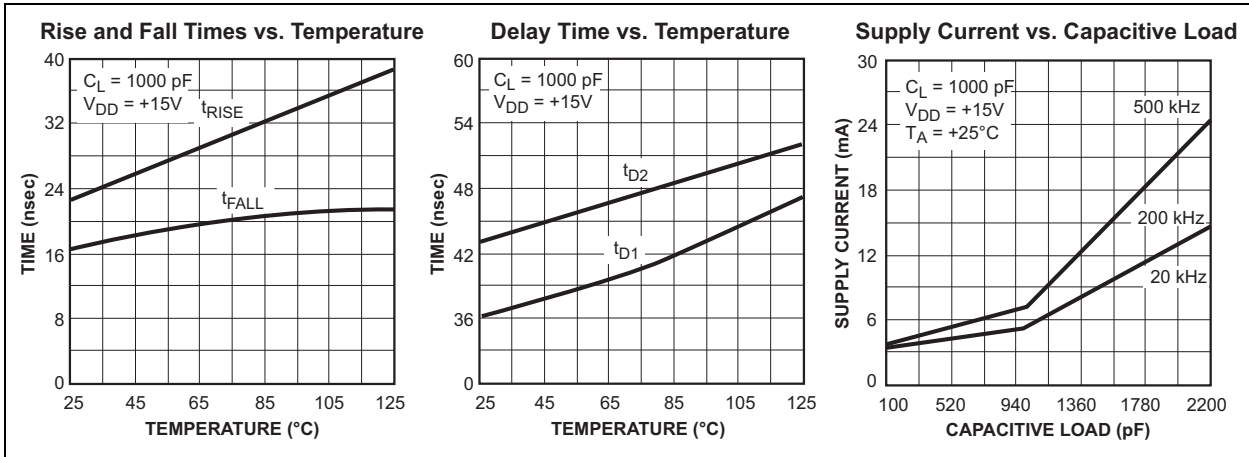
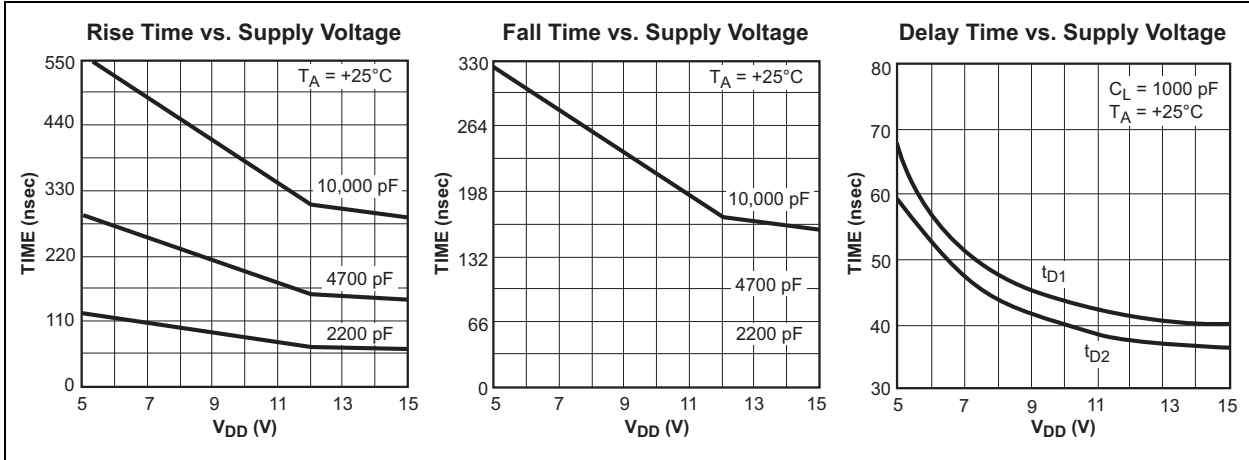

FIGURE 3-2: Noninverting Driver Switching Time

TC1426/TC1427/TC1428

4.0 TYPICAL CHARACTERISTICS

Note: The graphs and tables provided following this note are a statistical summary based on a limited number of samples and are provided for informational purposes only. The performance characteristics listed herein are not tested or guaranteed. In some graphs or tables, the data presented may be outside the specified operating range (e.g., outside specified power supply range) and therefore outside the warranted range.



TC1426/TC1427/TC1428

TYPICAL CHARACTERISTICS (CONTINUED)

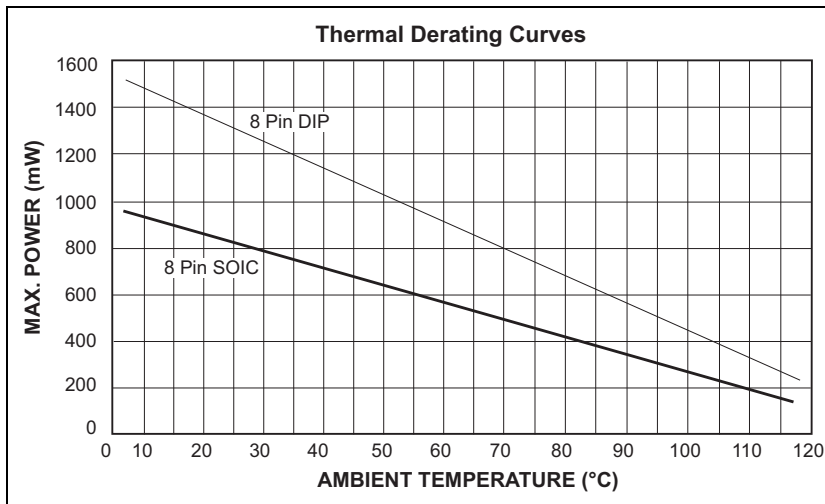
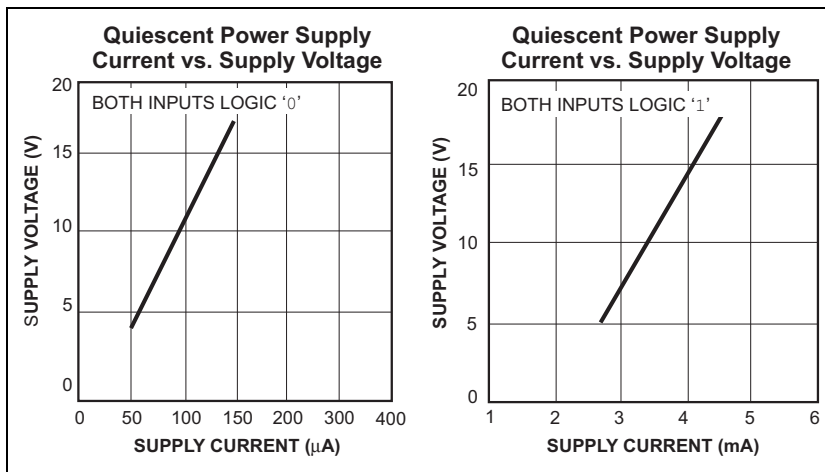
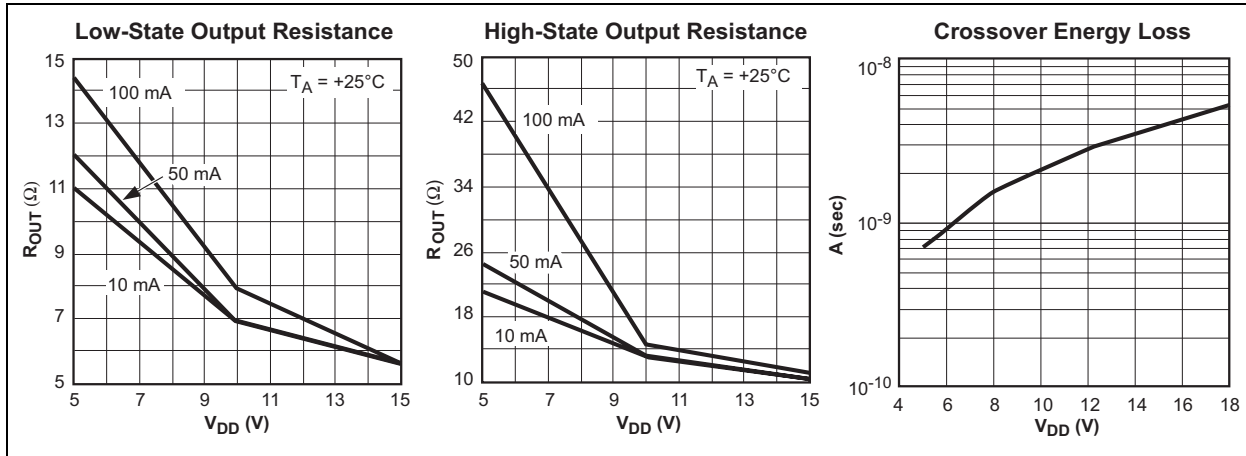

5.0 PACKAGING INFORMATION

5.1 Package Marking Information

Package marking data not available at this time.

5.2 Taping Form

Component Taping Orientation for 8-Pin MSOP Devices

Standard Reel Component Orientation
for 713 Suffix Device

Carrier Tape, Number of Components Per Reel and Reel Size

Package	Carrier Width (W)	Pitch (P)	Part Per Full Reel	Reel Size
8-Pin MSOP	12 mm	8 mm	2500	13 in

Component Taping Orientation for 8-Pin SOIC (Narrow) Devices

Standard Reel Component Orientation
for 713 Suffix Device

Carrier Tape, Number of Components Per Reel and Reel Size

Package	Carrier Width (W)	Pitch (P)	Part Per Full Reel	Reel Size
8-Pin SOIC (N)	12 mm	8 mm	2500	13 in

TC1426/TC1427/TC1428

5.3 Package Dimensions

Note: For the most current package drawings, please see the Microchip Packaging Specification located at <http://www.microchip.com/packaging>

8-Pin Plastic DIP

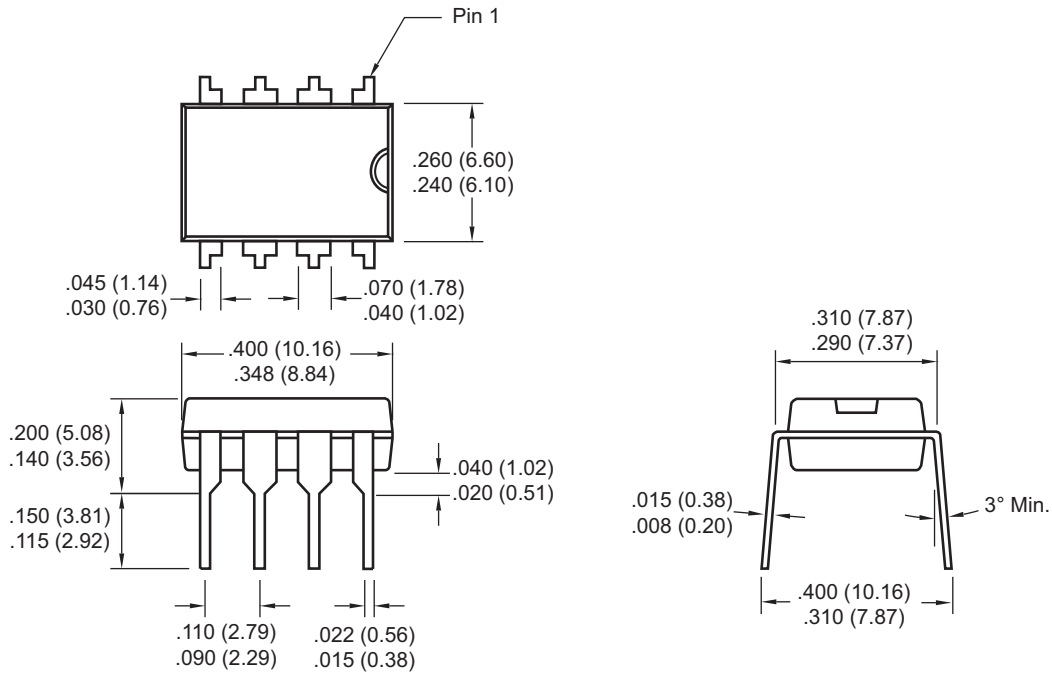

Dimensions: inches (mm)

Note: For the most current package drawings, please see the Microchip Packaging Specification located at <http://www.microchip.com/packaging>

8-Pin SOIC

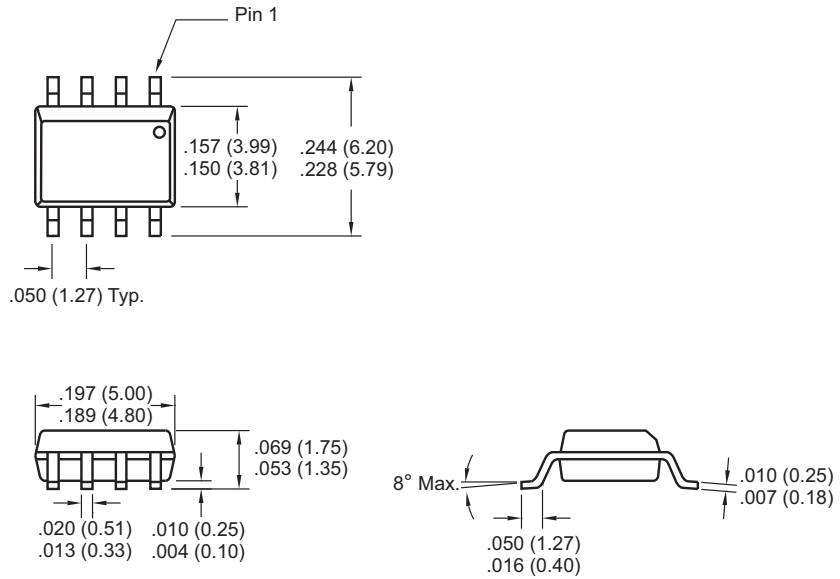

Dimensions: inches (mm)

TC1426/TC1427/TC1428

6.0 REVISION HISTORY

Revision D (December 2012)

Added a note to each package outline drawing.

THE MICROCHIP WEB SITE

Microchip provides online support via our WWW site at www.microchip.com. This web site is used as a means to make files and information easily available to customers. Accessible by using your favorite Internet browser, the web site contains the following information:

- **Product Support** – Data sheets and errata, application notes and sample programs, design resources, user's guides and hardware support documents, latest software releases and archived software
- **General Technical Support** – Frequently Asked Questions (FAQ), technical support requests, online discussion groups, Microchip consultant program member listing
- **Business of Microchip** – Product selector and ordering guides, latest Microchip press releases, listing of seminars and events, listings of Microchip sales offices, distributors and factory representatives

CUSTOMER CHANGE NOTIFICATION SERVICE

Microchip's customer notification service helps keep customers current on Microchip products. Subscribers will receive e-mail notification whenever there are changes, updates, revisions or errata related to a specified product family or development tool of interest.

To register, access the Microchip web site at www.microchip.com. Under "Support", click on "Customer Change Notification" and follow the registration instructions.

CUSTOMER SUPPORT

Users of Microchip products can receive assistance through several channels:

- Distributor or Representative
- Local Sales Office
- Field Application Engineer (FAE)
- Technical Support

Customers should contact their distributor, representative or field application engineer (FAE) for support. Local sales offices are also available to help customers. A listing of sales offices and locations is included in the back of this document.

Technical support is available through the web site at: <http://microchip.com/support>

TC1426/TC1427/TC1428

READER RESPONSE

It is our intention to provide you with the best documentation possible to ensure successful use of your Microchip product. If you wish to provide your comments on organization, clarity, subject matter, and ways in which our documentation can better serve you, please FAX your comments to the Technical Publications Manager at (480) 792-4150.

Please list the following information, and use this outline to provide us with your comments about this document.

TO: Technical Publications Manager Total Pages Sent _____

RE: Reader Response

From: Name _____

Company _____

Address _____

City / State / ZIP / Country _____

Telephone: (_____) _____ - _____ FAX: (_____) _____ - _____

Application (optional):

Would you like a reply? Y N

Device: TC1426/TC1427/TC1428

Literature Number: DS21393D

Questions:

1. What are the best features of this document?

2. How does this document meet your hardware and software development needs?

3. Do you find the organization of this document easy to follow? If not, why?

4. What additions to the document do you think would enhance the structure and subject?

5. What deletions from the document could be made without affecting the overall usefulness?

6. Is there any incorrect or misleading information (what and where)?

7. How would you improve this document?

Note the following details of the code protection feature on Microchip devices:

- Microchip products meet the specification contained in their particular Microchip Data Sheet.
- Microchip believes that its family of products is one of the most secure families of its kind on the market today, when used in the intended manner and under normal conditions.
- There are dishonest and possibly illegal methods used to breach the code protection feature. All of these methods, to our knowledge, require using the Microchip products in a manner outside the operating specifications contained in Microchip's Data Sheets. Most likely, the person doing so is engaged in theft of intellectual property.
- Microchip is willing to work with the customer who is concerned about the integrity of their code.
- Neither Microchip nor any other semiconductor manufacturer can guarantee the security of their code. Code protection does not mean that we are guaranteeing the product as “unbreakable.”

Code protection is constantly evolving. We at Microchip are committed to continuously improving the code protection features of our products. Attempts to break Microchip's code protection feature may be a violation of the Digital Millennium Copyright Act. If such acts allow unauthorized access to your software or other copyrighted work, you may have a right to sue for relief under that Act.

Information contained in this publication regarding device applications and the like is provided only for your convenience and may be superseded by updates. It is your responsibility to ensure that your application meets with your specifications. MICROCHIP MAKES NO REPRESENTATIONS OR WARRANTIES OF ANY KIND WHETHER EXPRESS OR IMPLIED, WRITTEN OR ORAL, STATUTORY OR OTHERWISE, RELATED TO THE INFORMATION, INCLUDING BUT NOT LIMITED TO ITS CONDITION, QUALITY, PERFORMANCE, MERCHANTABILITY OR FITNESS FOR PURPOSE. Microchip disclaims all liability arising from this information and its use. Use of Microchip devices in life support and/or safety applications is entirely at the buyer's risk, and the buyer agrees to defend, indemnify and hold harmless Microchip from any and all damages, claims, suits, or expenses resulting from such use. No licenses are conveyed, implicitly or otherwise, under any Microchip intellectual property rights.

Trademarks

The Microchip name and logo, the Microchip logo, dsPIC, FlashFlex, KEELOQ, KEELOQ logo, MPLAB, PIC, PICmicro, PICSTART, PIC³² logo, rPIC, SST, SST Logo, SuperFlash and UNI/O are registered trademarks of Microchip Technology Incorporated in the U.S.A. and other countries.

FilterLab, Hampshire, HI-TECH C, Linear Active Thermistor, MTP, SEEVAL and The Embedded Control Solutions Company are registered trademarks of Microchip Technology Incorporated in the U.S.A.

Silicon Storage Technology is a registered trademark of Microchip Technology Inc. in other countries.

Analog-for-the-Digital Age, Application Maestro, BodyCom, chipKIT, chipKIT logo, CodeGuard, dsPICDEM, dsPICDEM.net, dsPICworks, dsSPEAK, ECAN, ECONOMONITOR, FanSense, HI-TIDE, In-Circuit Serial Programming, ICSP, Mindi, MiWi, MPASM, MPF, MPLAB Certified logo, MPLIB, MPLINK, mTouch, Omniclient Code Generation, PICC, PICC-18, PICDEM, PICDEM.net, PICkit, PICtail, REAL ICE, rLAB, Select Mode, SQI, Serial Quad I/O, Total Endurance, TSHARC, UniWinDriver, WiperLock, ZENA and Z-Scale are trademarks of Microchip Technology Incorporated in the U.S.A. and other countries.

SQTP is a service mark of Microchip Technology Incorporated in the U.S.A.

GestIC and ULPP are registered trademarks of Microchip Technology Germany II GmbH & Co. & KG, a subsidiary of Microchip Technology Inc., in other countries.

All other trademarks mentioned herein are property of their respective companies.

© 2001-2012, Microchip Technology Incorporated, Printed in the U.S.A., All Rights Reserved.

 Printed on recycled paper.

ISBN: 9781620767887

QUALITY MANAGEMENT SYSTEM
CERTIFIED BY DNV
== ISO/TS 16949 ==

Microchip received ISO/TS-16949:2009 certification for its worldwide headquarters, design and wafer fabrication facilities in Chandler and Tempe, Arizona; Gresham, Oregon and design centers in California and India. The Company's quality system processes and procedures are for its PIC[®] MCUs and dsPIC[®] DSCs, KEELOQ[®] code hopping devices, Serial EEPROMs, microperipherals, nonvolatile memory and analog products. In addition, Microchip's quality system for the design and manufacture of development systems is ISO 9001:2000 certified.



MICROCHIP

Worldwide Sales and Service

AMERICAS

Corporate Office
2355 West Chandler Blvd.
Chandler, AZ 85224-6199
Tel: 480-792-7200
Fax: 480-792-7277
Technical Support:
<http://www.microchip.com/support>
Web Address:
www.microchip.com

Atlanta
Duluth, GA
Tel: 678-957-9614
Fax: 678-957-1455

Boston
Westborough, MA
Tel: 774-760-0087
Fax: 774-760-0088

Chicago
Itasca, IL
Tel: 630-285-0071
Fax: 630-285-0075

Cleveland
Independence, OH
Tel: 216-447-0464
Fax: 216-447-0643

Dallas
Addison, TX
Tel: 972-818-7423
Fax: 972-818-2924

Detroit
Farmington Hills, MI
Tel: 248-538-2250
Fax: 248-538-2260

Indianapolis
Noblesville, IN
Tel: 317-773-8323
Fax: 317-773-5453

Los Angeles
Mission Viejo, CA
Tel: 949-462-9523
Fax: 949-462-9608

Santa Clara
Santa Clara, CA
Tel: 408-961-6444
Fax: 408-961-6445

Toronto
Mississauga, Ontario,
Canada
Tel: 905-673-0699
Fax: 905-673-6509

ASIA/PACIFIC

Asia Pacific Office
Suites 3707-14, 37th Floor
Tower 6, The Gateway
Harbour City, Kowloon
Hong Kong
Tel: 852-2401-1200
Fax: 852-2401-3431

Australia - Sydney
Tel: 61-2-9868-6733
Fax: 61-2-9868-6755

China - Beijing
Tel: 86-10-8569-7000
Fax: 86-10-8528-2104

China - Chengdu
Tel: 86-28-8665-5511
Fax: 86-28-8665-7889

China - Chongqing
Tel: 86-23-8980-9588
Fax: 86-23-8980-9500

China - Hangzhou
Tel: 86-571-2819-3187
Fax: 86-571-2819-3189

China - Hong Kong SAR
Tel: 852-2943-5100
Fax: 852-2401-3431

China - Nanjing
Tel: 86-25-8473-2460
Fax: 86-25-8473-2470

China - Qingdao
Tel: 86-532-8502-7355
Fax: 86-532-8502-7205

China - Shanghai
Tel: 86-21-5407-5533
Fax: 86-21-5407-5066

China - Shenyang
Tel: 86-24-2334-2829
Fax: 86-24-2334-2393

China - Shenzhen
Tel: 86-755-8864-2200
Fax: 86-755-8203-1760

China - Wuhan
Tel: 86-27-5980-5300
Fax: 86-27-5980-5118

China - Xian
Tel: 86-29-8833-7252
Fax: 86-29-8833-7256

China - Xiamen
Tel: 86-592-2388138
Fax: 86-592-2388130

China - Zhuhai
Tel: 86-756-3210040
Fax: 86-756-3210049

ASIA/PACIFIC

India - Bangalore
Tel: 91-80-3090-4444
Fax: 91-80-3090-4123

India - New Delhi
Tel: 91-11-4160-8631
Fax: 91-11-4160-8632

India - Pune
Tel: 91-20-2566-1512
Fax: 91-20-2566-1513

Japan - Osaka
Tel: 81-66-152-7160
Fax: 81-66-152-9310

Japan - Yokohama
Tel: 81-45-471-6166
Fax: 81-45-471-6122

Korea - Daegu
Tel: 82-53-744-4301
Fax: 82-53-744-4302

Korea - Seoul
Tel: 82-2-554-7200
Fax: 82-2-558-5932 or
82-2-558-5934

Malaysia - Kuala Lumpur
Tel: 60-3-6201-9857
Fax: 60-3-6201-9859

Malaysia - Penang
Tel: 60-4-227-8870
Fax: 60-4-227-4068

Philippines - Manila
Tel: 63-2-634-9065
Fax: 63-2-634-9069

Singapore
Tel: 65-6334-8870
Fax: 65-6334-8850

Taiwan - Hsin Chu
Tel: 886-3-5778-366
Fax: 886-3-5770-955

Taiwan - Kaohsiung
Tel: 886-7-213-7828
Fax: 886-7-330-9305

Taiwan - Taipei
Tel: 886-2-2508-8600
Fax: 886-2-2508-0102

Thailand - Bangkok
Tel: 66-2-694-1351
Fax: 66-2-694-1350

EUROPE

Austria - Wels
Tel: 43-7242-2244-39
Fax: 43-7242-2244-393

Denmark - Copenhagen
Tel: 45-4450-2828
Fax: 45-4485-2829

France - Paris
Tel: 33-1-69-53-63-20
Fax: 33-1-69-30-90-79

Germany - Munich
Tel: 49-89-627-144-0
Fax: 49-89-627-144-44

Italy - Milan
Tel: 39-0331-742611
Fax: 39-0331-466781

Netherlands - Drunen
Tel: 31-416-690399
Fax: 31-416-690340

Spain - Madrid
Tel: 34-91-708-08-90
Fax: 34-91-708-08-91

UK - Wokingham
Tel: 44-118-921-5869
Fax: 44-118-921-5820

11/27/12

Looking for pricing, stock, or lifecycle information?

Click below to explore more details on WIN SOURCE:

- ⊖ [View TC1426COA on WIN SOURCE](#)
- ⊖ [Microchip Technology](#) Information

Optimize Your Supply Chain with WIN SOURCE Solutions

- ✓ Global Sourcing Solution
- ✓ Obsolete Management
- ✓ Cost Control Management
- ✓ Shortage Management
- ✓ Alternative Solution
- ✓ Excess Inventory Management