



**THE DATASHEET OF
74VHC393MTCX**



74VHC393 Dual 4-Bit Binary Counter

Features

- High Speed: $f_{MAX} = 170\text{MHz}$ (Typ.) at $T_A = 25^\circ\text{C}$
- Low power dissipation: $I_{CC} = 4\mu\text{A}$ (Max.) at $T_A = 25^\circ\text{C}$
- High noise immunity: $V_{NIH} = V_{NIL} = 28\% V_{CC}$ (Min.)
- Power down protection is provided on all inputs
- Pin and function compatible with 74HC393

General Description

The VHC393 is an advanced high speed CMOS 4-bit Binary Counter fabricated with silicon gate CMOS technology. It achieves the high speed operation similar to equivalent Bipolar Schottky TTL while maintaining the CMOS low power dissipation. It contains two independent counter circuits in one package, so that counting or frequency division of 8 binary bits can be achieved with one IC. This device changes state on the negative going transition of the $\overline{\text{CLOCK}}$ pulse. The counter can be reset to "0" ($Q_0-Q_3 = \text{"L"}$) by a HIGH at the CLEAR input regardless of other inputs.

An input protection circuit ensures that 0V to 7V can be applied to the input pins without regard to the supply voltage. This device can be used to interface 5V to 3V systems and two supply systems such as battery back up. This circuit prevents device destruction due to mismatched supply and input voltages.

Ordering Information

Order Number	Package Number	Package Description
74VHC393M	M14A	14-Lead Small Outline Integrated Circuit (SOIC), JEDEC MS-012, 0.150" Narrow
74VHC393SJ	M14D	14-Lead Small Outline Package (SOP), EIAJ TYPE II, 5.3mm Wide
74VHC393MTC	MTC14	14-Lead Thin Shrink Small Outline Package (TSSOP), JEDEC MO-153, 4.4mm Wide

Device also available in Tape and Reel. Specify by appending suffix letter "X" to the ordering number.

 All packages are lead free per JEDEC: J-STD-020B standard.

Connection Diagram

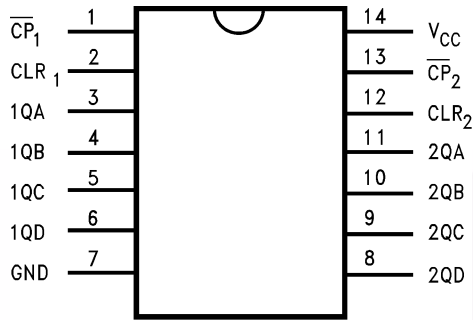

Logic Symbol/s

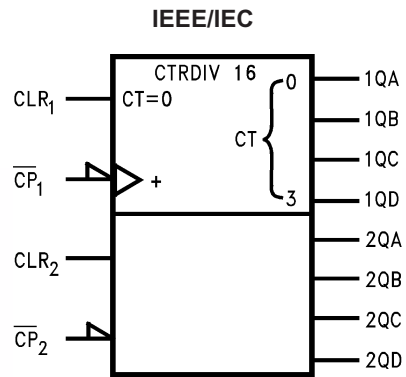

Pin Descriptions

Pin Names	Description
CLR ₁ , CLR ₂	Clear Inputs
\overline{CP}_1 , \overline{CP}_2	Clock Pulse Inputs
QA, QB, QC, QD	Outputs

Truth Table

Inputs		Outputs			
\overline{CP}	CLR	QA	QB	QC	QD
X	H	L	L	L	L
$\overline{\text{L}}$	L	Count Up			
L	L	No Change			

X: Don't Care

System Diagram

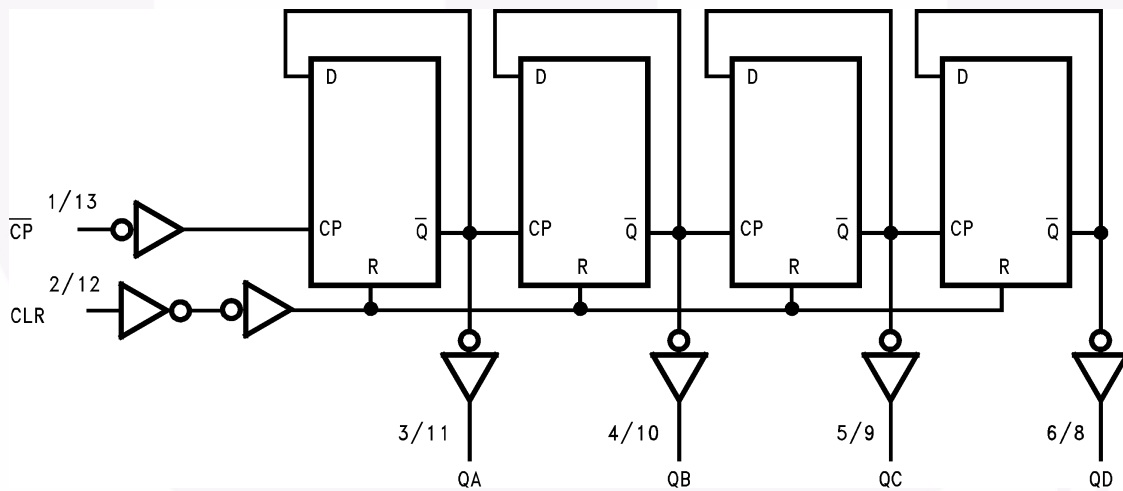

Timing Chart

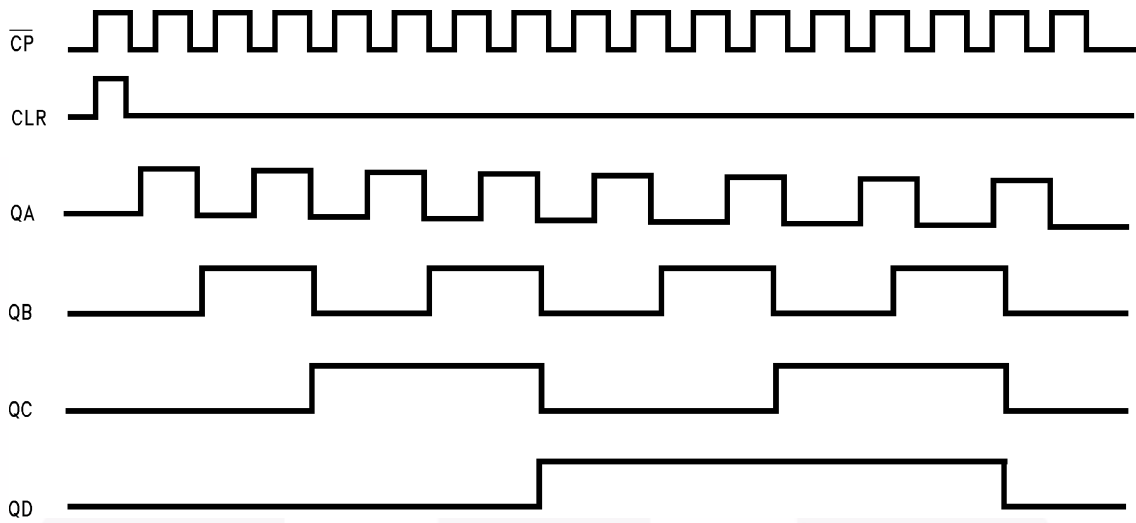

Absolute Maximum Ratings

Stresses exceeding the absolute maximum ratings may damage the device. The device may not function or be operable above the recommended operating conditions and stressing the parts to these levels is not recommended. In addition, extended exposure to stresses above the recommended operating conditions may affect device reliability. The absolute maximum ratings are stress ratings only.

Symbol	Parameter	Rating
V_{CC}	Supply Voltage	-0.5V to +7.0V
V_{IN}	DC Input Voltage	-0.5V to +7.0V
V_{OUT}	DC Output Voltage	-0.5V to $V_{CC} + 0.5V$
I_{IK}	Input Diode Current	-20mA
I_{OK}	Output Diode Current ⁽⁴⁾	$\pm 20mA$
I_{OUT}	DC Output Current	$\pm 25mA$
I_{CC}	DC V_{CC} /GND Current	$\pm 75mA$
T_{STG}	Storage Temperature	-65°C to +150°C
T_L	Lead Temperature (Soldering, 10 seconds)	260°C

Recommended Operating Conditions⁽¹⁾

The Recommended Operating Conditions table defines the conditions for actual device operation. Recommended operating conditions are specified to ensure optimal performance to the datasheet specifications. Fairchild does not recommend exceeding them or designing to absolute maximum ratings.

Symbol	Parameter	Rating
V_{CC}	Supply Voltage	2.0V to +5.5V
V_{IN}	Input Voltage	0V to +5.5V
V_{OUT}	Output Voltage	0V to V_{CC}
T_{OPR}	Operating Temperature	-40°C to +85°C
t_r, t_f	Input Rise and Fall Time $V_{CC} = 3.3V \pm 0.3V$ $V_{CC} = 5.0V \pm 0.5V$	0 ~ 100ns/V 0 ~ 20ns/V

Note:

1. Unused inputs must be held HIGH or LOW. They may not float.

DC Electrical Characteristics

Symbol	Parameter	V_{CC} (V)	Conditions	$T_A = 25^\circ\text{C}$			$T_A = -40^\circ\text{C}$ to $+85^\circ\text{C}$		Units	
				Min.	Typ.	Max.	Min.	Max.		
V_{IH}	HIGH Level Input Voltage	2.0		1.50			1.50		V	
		3.0 – 5.5		$0.7 \times V_{CC}$			$0.7 \times V_{CC}$			
V_{IL}	LOW Level Input Voltage	2.0				0.50		0.50	V	
		3.0 – 5.5				$0.3 \times V_{CC}$		$0.3 \times V_{CC}$		
V_{OH}	HIGH Level Output Voltage	2.0	$V_{IN} = V_{IH}$ or V_{IL}	$I_{OH} = -50\mu\text{A}$	1.9	2.0		1.9		V
		3.0			2.9	3.0		2.9		
		4.5			4.4	4.5		4.4		
		3.0		$I_{OH} = -4\text{mA}$	2.58			2.48		V
		4.5		$I_{OH} = -8\text{mA}$	3.94			3.80		
V_{OL}	LOW Level Output Voltage	2.0	$V_{IN} = V_{IH}$ or V_{IL}	$I_{OL} = 50\mu\text{A}$		0.0	0.1		0.1	V
		3.0				0.0	0.1		0.1	
		4.5				0.0	0.1		0.1	
		3.0		$I_{OL} = 4\text{mA}$			0.36		0.44	V
		4.5		$I_{OL} = 8\text{mA}$			0.36		0.44	
I_{IN}	Input Leakage Current	0 – 5.5	$V_{IN} = 5.5\text{V}$ or GND			± 0.1		± 1.0	μA	
I_{CC}	Quiescent Supply Current	5.5	$V_{IN} = V_{CC}$ or GND			4.0		40.0	μA	

AC Electrical Characteristics

Symbol	Parameter	V _{CC} (V)	Conditions	T _A = 25°C			T _A = -40°C to +85°C		Units
				Min.	Typ.	Max.	Min.	Max.	
t _{PLH} , t _{PHL}	Propagation Delay Time (CP-QA)	3.3 ± 0.3	C _L = 15pF		8.6	13.2	1.0	15.5	ns
			C _L = 50pF		11.1	16.7	1.0	19.0	
		5.0 ± 0.5	C _L = 15pF		5.8	8.5	1.0	10.0	
			C _L = 50pF		7.3	10.5	1.0	12.0	
t _{PLH} , t _{PHL}	Propagation Delay Time (CP-QB)	3.3 ± 0.3	C _L = 15pF		10.2	15.8	1.0	18.5	ns
			C _L = 50pF		12.7	19.3	1.0	22.0	
		5.0 ± 0.5	C _L = 15pF		6.8	9.8	1.0	11.5	
			C _L = 50pF		8.3	11.8	1.0	13.5	
t _{PLH} , t _{PHL}	Propagation Delay Time (CP-QC)	3.3 ± 0.3	C _L = 15pF		11.7	18.0	1.0	21.0	ns
			C _L = 50pF		14.2	21.5	1.0	24.5	
		5.0 ± 0.5	C _L = 15pF		7.7	11.2	1.0	13.0	
			C _L = 50pF		9.2	13.2	1.0	15.0	
t _{PLH} , t _{PHL}	Propagation Delay Time (CP-QD)	3.3 ± 0.3	C _L = 15pF		13.0	19.7	1.0	23.0	ns
			C _L = 50pF		15.5	23.2	1.0	26.5	
		5.0 ± 0.5	C _L = 15pF		8.5	12.5	1.0	14.5	
			C _L = 50pF		10.0	14.5	1.0	16.5	
t _{PLH} , t _{PHL}	Propagation Delay Time (CLR-Q _n)	3.3 ± 0.3	C _L = 15pF		7.9	12.3	1.0	14.5	ns
			C _L = 50pF		10.4	15.8	1.0	18.0	
		5.0 ± 0.5	C _L = 15pF		5.4	8.1	1.0	9.5	
			C _L = 50pF		6.9	10.1	1.0	11.5	
f _{MAX}	Maximum Clock	3.3 ± 0.3	C _L = 15pF	75	120		65	MHz	
			C _L = 50pF	45	65		35		
		5.0 ± 0.5	C _L = 15pF	125	170		105		
			C _L = 50pF	85	115		75		
C _{IN}	Input Capacitance		V _{CC} = Open		4	10		10	pF
C _{PD}	Power Dissipation Capacitance		(2)		23				pF

Note:

2. C_{PD} is defined as the value of the internal equivalent capacitance which is calculated from the operating current consumption without load. Average operating current can be obtained by the equation:

$$I_{CC(Oper.)} = C_{PD} \cdot V_{CC} \cdot f_{IN} + I_{CC} / 2 \text{ (per Counter)}$$

AC Operating Requirements

Symbol	Parameter	V _{CC} (V)	T _A = 25°C		T _A = -40°C to +85°C		Units
			Typ.	Guaranteed Minimum	Guaranteed Minimum	Guaranteed Minimum	
t _{W(L)} , t _{W(H)}	Minimum Pulse Width (CP)	3.3 ± 0.3		5.0	5.0	ns	
		5.0 ± 0.5		5.0	5.0		
t _{W(H)}	Minimum Pulse Width (CLR)	3.3 ± 0.3		5.0	5.0	ns	
		5.0 ± 0.5		5.0	5.0		
t _{REM}	Minimum Removal Time	3.3 ± 0.3		5.0	5.0	ns	
		5.0 ± 0.5		4.0	4.0		

Physical Dimensions

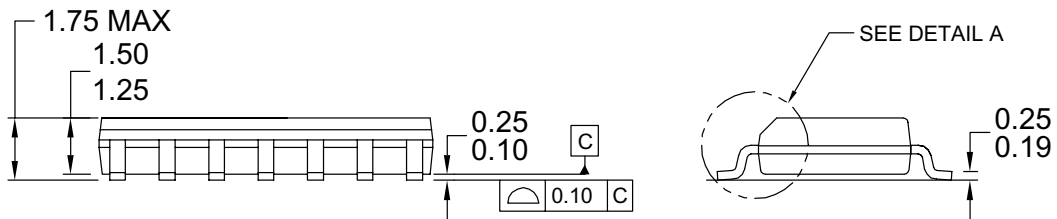
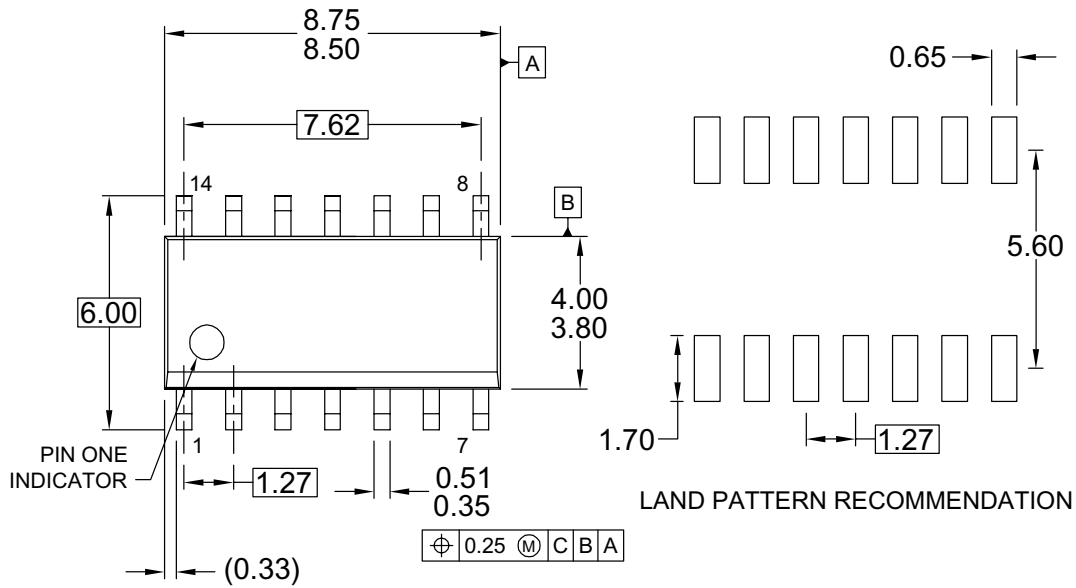

NOTES: UNLESS OTHERWISE SPECIFIED

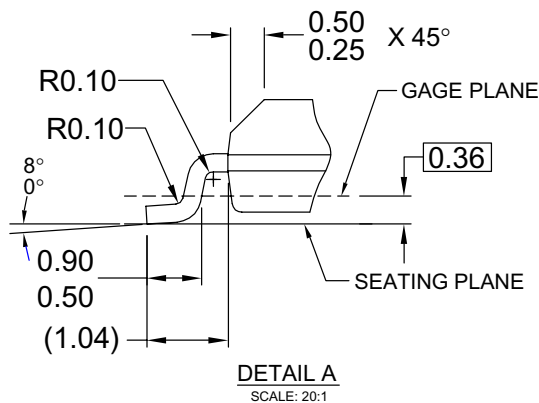

- A) THIS PACKAGE CONFORMS TO JEDEC MS-012, VARIATION AB, ISSUE C,
- B) ALL DIMENSIONS ARE IN MILLIMETERS.
- C) DIMENSIONS DO NOT INCLUDE MOLD FLASH OR BURRS.
- D) LANDPATTERN STANDARD: SOIC127P600X145-14M
- E) DRAWING CONFORMS TO ASME Y14.5M-1994
- F) DRAWING FILE NAME: M14AREV13

Figure 1. 14-Lead Small Outline Integrated Circuit (SOIC), JEDEC MS-012, 0.150" Narrow

Package drawings are provided as a service to customers considering Fairchild components. Drawings may change in any manner without notice. Please note the revision and/or date on the drawing and contact a Fairchild Semiconductor representative to verify or obtain the most recent revision. Package specifications do not expand the terms of Fairchild's worldwide terms and conditions, specifically the warranty therein, which covers Fairchild products.

Always visit Fairchild Semiconductor's online packaging area for the most recent package drawings:

<http://www.fairchildsemi.com/packaging/>

Physical Dimensions (Continued)

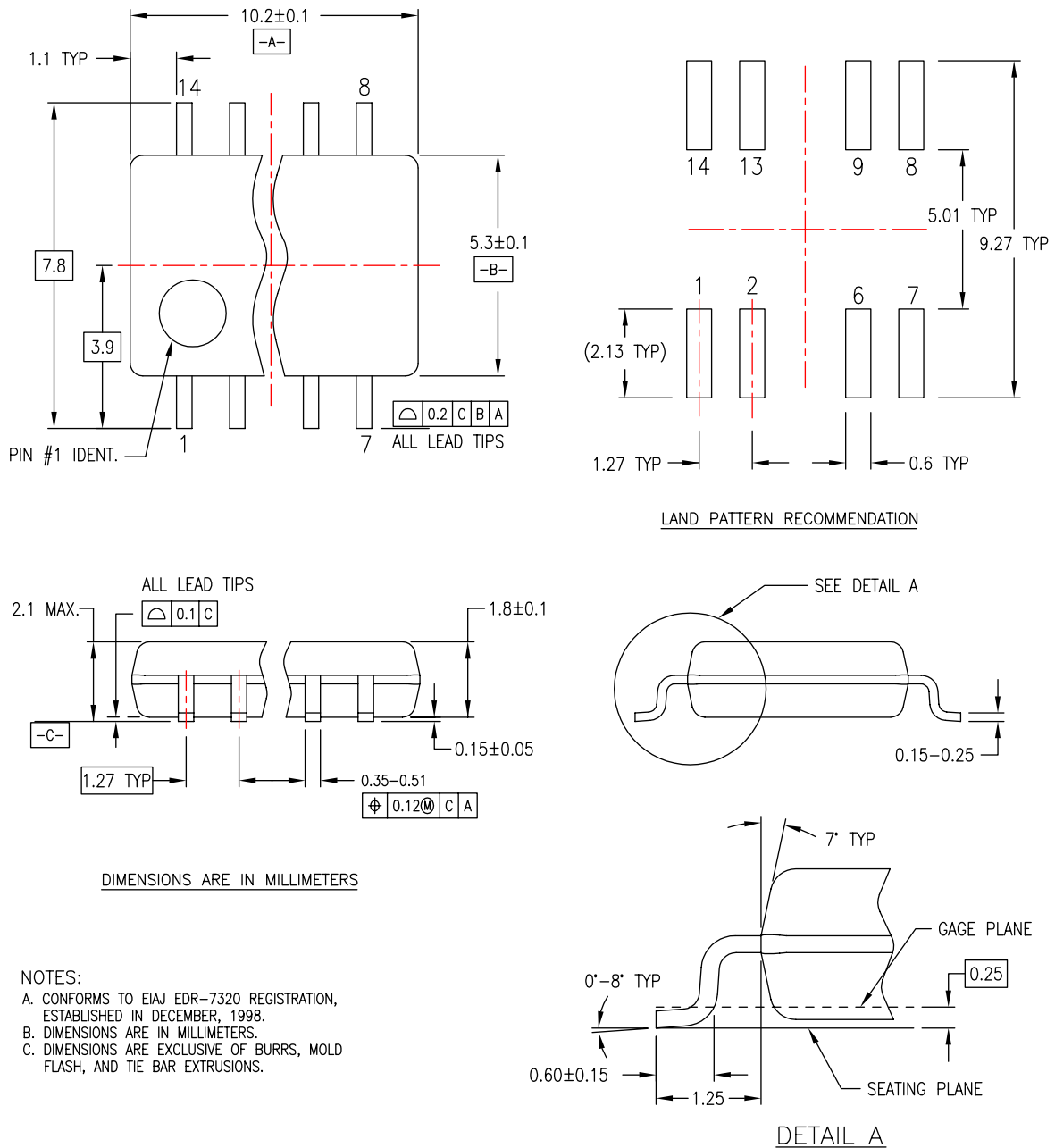

M14DREVC

Figure 2. 14-Lead Small Outline Package (SOP), EIAJ TYPE II, 5.3mm Wide

Package drawings are provided as a service to customers considering Fairchild components. Drawings may change in any manner without notice. Please note the revision and/or date on the drawing and contact a Fairchild Semiconductor representative to verify or obtain the most recent revision. Package specifications do not expand the terms of Fairchild's worldwide terms and conditions, specifically the warranty therein, which covers Fairchild products.



Always visit Fairchild Semiconductor's online packaging area for the most recent package drawings:

<http://www.fairchildsemi.com/packaging/>



TRADEMARKS

The following includes registered and unregistered trademarks and service marks, owned by Fairchild Semiconductor and/or its global subsidiaries, and is not intended to be an exhaustive list of all such trademarks.

ACEx®	FPST™	PDP-SPM™	SyncFET™
Build it Now™	FRFET®	Power220®	SYSTEM GENERAL®
CorePLUS™	Global Power Resource™	Power247®	The Power Franchise®
CROSSVOLT™	Green FPS™	POWEREDGE®	the power®
CTL™	Green FPS™ e-Series™	Power-SPM™	franchise
Current Transfer Logic™	GTO™	PowerTrench®	TinyBoost™
EcoSPARK®	i-Lo™	Programmable Active Droop™	TinyBuck™
EZSWITCH™ *	IntelliMAX™	QFET®	TinyLogic®
 ™	ISOPLANAR™	QST™	TINYOPTO™
 ™	MegaBuck™	QT Optoelectronics™	TinyPower™
Fairchild®	MICROCOUPLER™	Quiet Series™	TinyPWM™
Fairchild Semiconductor®	MicroFET™	RapidConfigure™	TinyWire™
FACT Quiet Series™	MicroPak™	SMART START™	µSerDes™
FACT®	MillerDrive™	SPM®	UHC®
FAST®	Motion-SPM™	STEALTH™	Ultra FRFET™
FastvCore™ *	OPTOLOGIC®	SuperFET™	UniFET™
FlashWriter® *	OPTOPLANAR®	SuperSOT™-3	VCX™
		SuperSOT™-6	
		SuperSOT™-8	

* EZSWITCH™ and FlashWriter® are trademarks of System General Corporation, used under license by Fairchild Semiconductor.

DISCLAIMER

FAIRCHILD SEMICONDUCTOR RESERVES THE RIGHT TO MAKE CHANGES WITHOUT FURTHER NOTICE TO ANY PRODUCTS HEREIN TO IMPROVE RELIABILITY, FUNCTION, OR DESIGN. FAIRCHILD DOES NOT ASSUME ANY LIABILITY ARISING OUT OF THE APPLICATION OR USE OF ANY PRODUCT OR CIRCUIT DESCRIBED HEREIN; NEITHER DOES IT CONVEY ANY LICENSE UNDER ITS PATENT RIGHTS, NOR THE RIGHTS OF OTHERS. THESE SPECIFICATIONS DO NOT EXPAND THE TERMS OF FAIRCHILD'S WORLDWIDE TERMS AND CONDITIONS, SPECIFICALLY THE WARRANTY THEREIN, WHICH COVERS THESE PRODUCTS.

LIFE SUPPORT POLICY

FAIRCHILD'S PRODUCTS ARE NOT AUTHORIZED FOR USE AS CRITICAL COMPONENTS IN LIFE SUPPORT DEVICES OR SYSTEMS WITHOUT THE EXPRESS WRITTEN APPROVAL OF FAIRCHILD SEMICONDUCTOR CORPORATION.

As used herein:

1. Life support devices or systems are devices or systems which, (a) are intended for surgical implant into the body or (b) support or sustain life, and (c) whose failure to perform when properly used in accordance with instructions for use provided in the labeling, can be reasonably expected to result in a significant injury of the user.
2. A critical component in any component of a life support, device, or system whose failure to perform can be reasonably expected to cause the failure of the life support device or system, or to affect its safety or effectiveness.

PRODUCT STATUS DEFINITIONS

Definition of Terms

Datasheet Identification	Product Status	Definition
Advance Information	Formative or In Design	This datasheet contains the design specifications for product development. Specifications may change in any manner without notice.
Preliminary	First Production	This datasheet contains preliminary data; supplementary data will be published at a later date. Fairchild Semiconductor reserves the right to make changes at any time without notice to improve design.
No Identification Needed	Full Production	This datasheet contains final specifications. Fairchild Semiconductor reserves the right to make changes at any time without notice to improve the design.
Obsolete	Not In Production	This datasheet contains specifications on a product that has been discontinued by Fairchild Semiconductor. The datasheet is printed for reference information only.

Rev. I32

Looking for pricing, stock, or lifecycle information?

Click below to explore more details on WIN SOURCE:

-  [View 74VHC393MTCX on WIN SOURCE](#)
-  [Fairchild/ON Semiconductor Information](#)

Optimize Your Supply Chain with WIN SOURCE Solutions

-  Global Sourcing Solution
-  Obsolete Management
-  Cost Control Management
-  Shortage Management
-  Alternative Solution
-  Excess Inventory Management