

TOSHIBA BiCD Integrated Circuit Silicon Monolithic

# TB6607FLG

## DC and Stepping Motor Driver IC

The TB6607FLG is a DC motor driver IC using LDMOS output transistors with low ON-resistance.

The TB6607FLG incorporates two PWM-controlled, constant-current H-bridge drivers and three direct-PWM-controlled H-bridge drivers. The TB6607FLG is best suited to control various lens actuators in digital still cameras.

The drivers of the TB6607FLG are controlled via a three-wire serial interface, thus reducing the number of lines required for interfacing with the control IC.

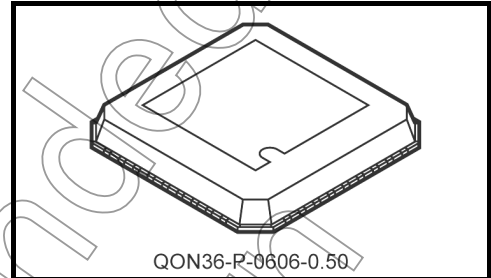

Weight: 0.08 g (typ.)

### Features

- Motor power supply voltage:  $V_M \leq 6$  V (max)
- Control power supply voltage:  $V_{CC} = 2.7$  to 6 V
- Output current:  $I_{OUT} \leq 0.8$  A (max)
- Complementary P- and N-channel LDMOS output transistors
- Output ON-resistance:  $R_{ON}$  (upper and lower sum at) =  $1.5 \Omega$  (typ.)

Channels D and E: Constant-current H-bridge drivers

- Produces low-ripple current with high-speed PWM control at several hundred kHz

Channels A, B and C: Stepping motor drivers

- Three H-bridge drivers for direct PWM control

Other Features

- Two 6-bit DACs provide reference values for constant-current limiters
- Independent Standby (power-save) mode
- Thermal shutdown (TSD): Disables the output bias generator when the internal junction temperature exceeds  $170^\circ\text{C}$ .
- Undervoltage lockout (UVLO): Resets and disables the internal circuitry when  $V_{CC}$  falls below 2.2 V (typ.)
- Small QON-36 package (0.5-mm lead pitch)
- Compatible with Pb-free reflow soldering

Note: This product has a MOS structure and is sensitive to electrostatic discharge. When handling this product, ensure that the environment is protected against electrostatic discharge by using an earth strap, a conductive mat and an ionizer. Ensure also that the ambient temperature and relative humidity are maintained at reasonable levels.

The TB6607FLG is a Pb-free product.

About solderability, following conditions were confirmed

- Solderability
  - (1) Use of Sn-37Pb solder Bath
    - solder bath temperature =  $230^\circ\text{C}$
    - dipping time = 5 seconds
    - the number of times = once
    - use of R-type flux
  - (2) Use of Sn-3.0Ag-0.5Cu solder Bath
    - solder bath temperature =  $245^\circ\text{C}$
    - dipping time = 5 seconds
    - the number of times = once
    - use of R-type flux

**Block Diagram**

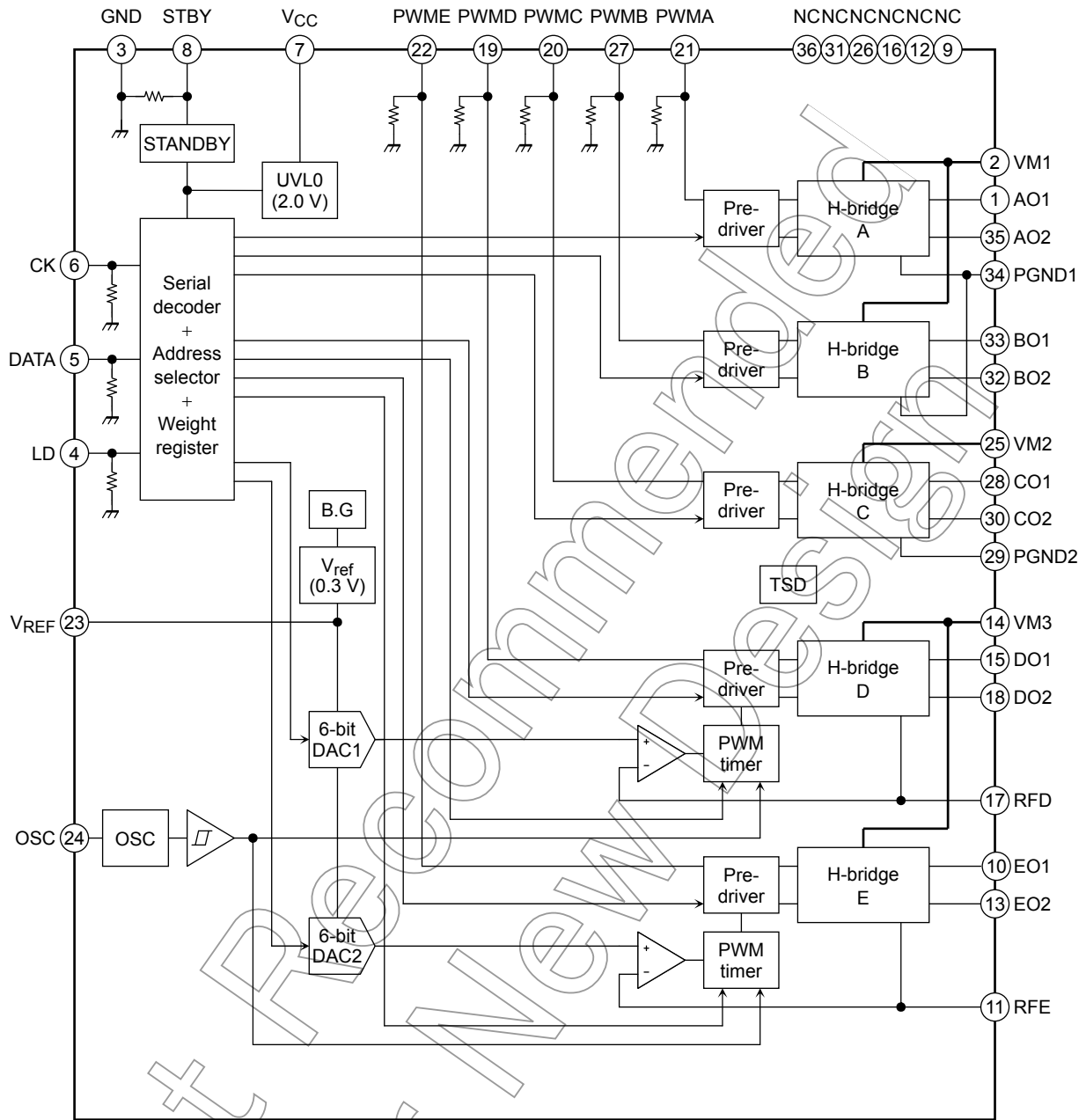

Not for Newbies

## Pin Function

No.	Pin Name	I/O	Function
1	AO1	O	Channel-A output 1
2	VM1	—	Motor power supply 1
3	GND	—	Ground
4	LD	I	Serial load enable
5	DATA	I	Serial data input
6	CK	I	Serial clock input
7	VCC	—	Power supply pin
8	STBY	I	Standby (power-save) control input
9	NC	—	No-connect
10	EO1	O	Channel-E output 1
11	RFE	—	Connection pin for a current sensing resistor (Channel-E)
12	NC	—	No-connect
13	EO2	O	Channel-E output 2
14	VM3	—	Motor power supply 3
15	DO1	O	Channel-D output 1
16	NC	—	No-connect
17	RFD	—	Connection pin for a current sensing resistor (Channel-D)
18	DO2	O	D-channel output 2
19	PWMD	I	PWM signal input (Channel-D)
20	PWMC	I	PWM signal input (Channel-C)
21	PWMA	I	PWM signal input (Channel-A)
22	PWME	I	PWM signal input (Channel-E)
23	VREF	O	Reference voltage output (0.3 V)
24	OSC	—	Connection pin for an external capacitor for on-chip oscillation
25	VM2	—	Motor power supply 2
26	NC	—	No-connect
27	PWMB	I	PWM signal input (Channel-B)
28	CO1	O	Channel-C output 1
29	PGND2	—	Motor ground pin 2
30	CO2	O	Channel-C output 2
31	NC	—	No-connect
32	BO2	O	Channel-B output 2
33	BO1	O	Channel-B output 1
34	PGND1	—	Motor ground pin 1
35	AO2	O	Channel-A output 2
36	NC	—	No-connect

## Absolute Maximum Ratings (Ta = 25°C)

Characteristics	Symbol	Rating	Unit	Remarks
Supply voltage	V <sub>CC</sub>	6	V	V <sub>CC</sub>
Motor supply voltage	V <sub>M</sub>	6	V	V <sub>M</sub>
Output voltage	V <sub>OUT</sub>	-0.2 to 6	V	
Output current	I <sub>OUT</sub>	0.8	A	
Input voltage	V <sub>IN</sub>	-0.2 to 6	V	Control input pins
Power dissipation	P <sub>D</sub>	0.6	W	IC only
		1.04	W	(Note)
Operating temperature	T <sub>opr</sub>	-20 to 85	°C	
Storage temperature	T <sub>stg</sub>	-55 to 150	°C	

Note: When mounted on a single-sided glass epoxy PCB (size: 50 mm × 50 mm × 1.6 mm) with a 40% dissipating copper surface.

## Operating Conditions (Ta = -20 to 85°C)

Characteristics	Symbol	Min	Typ.	Max	Unit	
Supply voltage for small-signal circuitry	V <sub>CC</sub>	2.7	3	5.5	V	
Motor supply voltage	V <sub>M</sub>	2.5	5	5.5	V	
Output current	I <sub>OUT</sub>	—	—	600	mA	V <sub>M</sub> = 3 to 5.5 V
				350		2.2 V ≤ V <sub>M</sub> ≤ 3 V
PWM frequency	f <sub>pwm</sub>	—	—	500	kHz	
OSC frequency	f <sub>osc</sub>	—	—	1	MHz	

Not Recommended for New Design

**Operating Conditions: Serial Data Controller (Ta = -20 to 85°C)**

Characteristics	Symbol	Min	Max	Unit
Clock pulse width Low	t <sub>CKL</sub>	200	—	ns
Clock pulse width High	t <sub>CKH</sub>	200	—	ns
Clock rise time	t <sub>Cr</sub>	—	50	ns
Clock fall time	t <sub>Cf</sub>	—	50	ns
Data setup time	t <sub>DCH</sub>	30	—	ns
Data hold time	t <sub>CHD</sub>	60	—	ns
LD setup time	t <sub>CHL</sub>	200	—	ns
LD hold time	t <sub>LDC</sub>	200	—	ns
LD to PWM delay	t <sub>LDC2</sub>	100	—	ns
Load pulse width High	t <sub>LDH</sub>	2	—	μs
CK frequency	f <sub>CLK</sub>	—	5	MHz

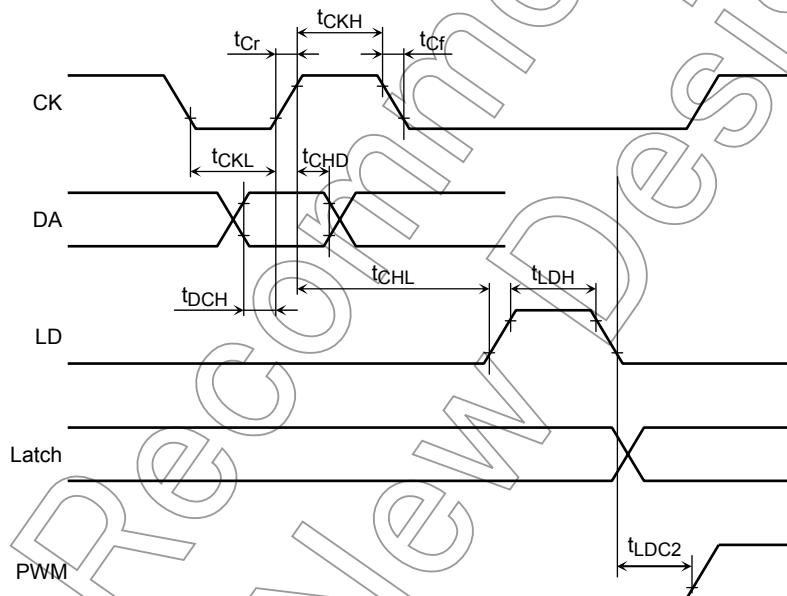

Not Recommended for New Design

**Principle of Operation:**

**Bridge Outputs: Channels A through E**

**PWM Control**

In PWM constant-current mode, the PWM chopper circuit alternates between on ( $t_1, t_5$ ) and short brake ( $t_3$ ).

(To eliminate shoot-through current, a dead time ( $t_2, t_4$ ) is inserted when the PWM is turned on and off.)

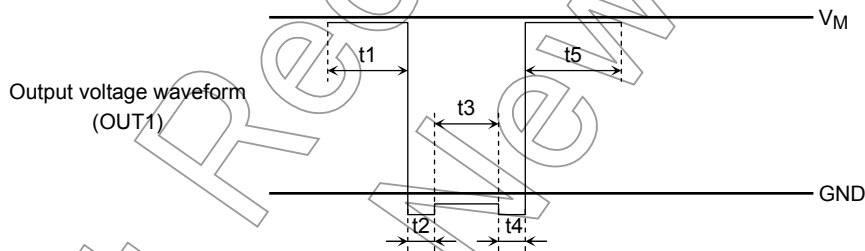
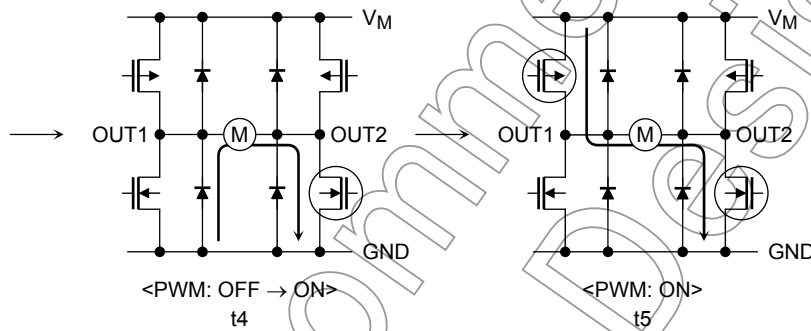
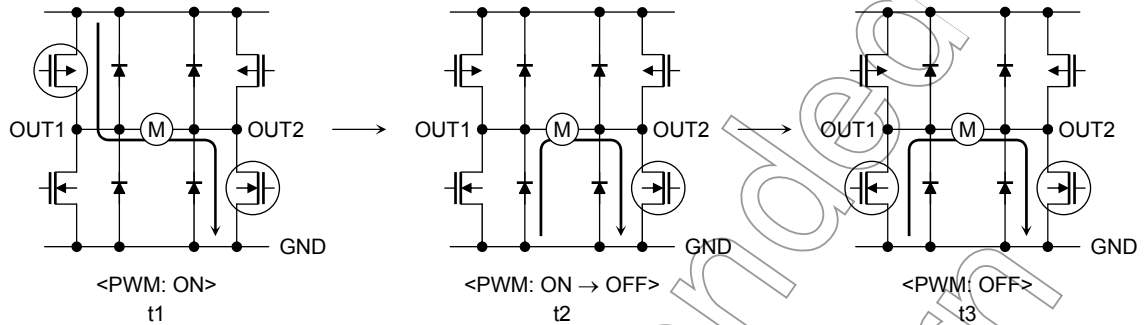

Not for

Oscillator Operation: The on-chip oscillation is controlled by the charging and discharging of an external capacitor (COSC).

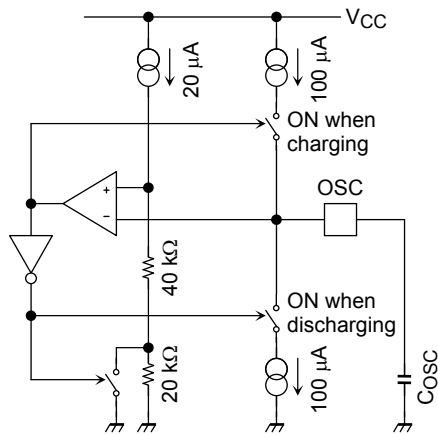

**Oscillator**

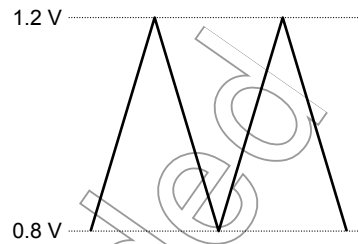

**Vosc Waveform**

In the above circuit, the charging and discharging rate (Vosc) of the external capacitor is calculated as follows:

$$V_{OSC} = \frac{1}{C_{OSC}} \int i dt$$

Let the time at VOSC = 0.8 V be t1 and the time at VOSC = 1.2 V be t2, then the VOSC slope (ΔVOSC) is calculated as:

$$\Delta V_{OSC} = I \times (t_1 - t_2) / C_{OSC}$$

which can be rewritten as:

$$\frac{1}{t_1 - t_2} = \frac{I}{\Delta V_{OSC} \cdot C_{OSC}}$$

The cycle period of the triangular wave oscillation is equal to the period of rise and fall times of VOSC slope, which is, twice the time from t1 to t2.

Hence, fOSC can be expressed as a function of COSC as follows:

$$f_{OSC} = \frac{1}{2(t_1 - t_2)} = \frac{I}{2 \cdot \Delta V_{OSC} \cdot C_{OSC}}$$

In the above diagrams, ΔVOSC = |1.2 V - 0.8 V| = 0.4 V. Thus, fOSC can be calculated as:

$$f_{OSC} = \frac{1}{2 \times 0.4 / 100 \mu A \times C_{OSC}} = \frac{1}{6.957 \times 10^3 \times C_{OSC}}$$

Examples: fOSC = 532 kHz when COSC = 270 pF  
 fOSC = 256 kHz when COSC = 560 pF

In actual applications, however, the capacitance required for COSC may slightly differ from the theoretical value due to the board capacitance on the OSC pin and other factors. It is therefore recommended to adjust the external capacitor value (COSC) experimentally.

- Constant-Current Bridges (Channels D and E): PWM constant-current choppers

The TB6607FLG has PWM choppers with a constant turn-off period.

The TB6607FLG measures the turn-off period by counting the number of rising edges of the externally applied CLK signal. The turn-off period can be changed by changing either the CLK frequency or the number of its rising edges counted (three or five counts; the default is five counts).

Turning on the power supply causes a current to flow into the motor coils. The peak current through the winding is sensed via an external current-sensing resistor. As the current increases, a voltage (VRF) develops across the resistor, which is fed back to the comparator. At the predetermined reference voltage (Vlimit), the comparator turns off (chops) the power supply.

When high-side output transistors are turned off, the TB6607FLG, by default, counts five rising edges of the internal CK signal as turn-off period. (The counter resets at the sixth rising edge of CK.)

Based on this turn-off period, the TB6607FLG generates a PWM signal that turns on and off the output transistors.

Timing Diagram of the PWM Constant-Current Chopper Circuit with the Default Turn-Off Period

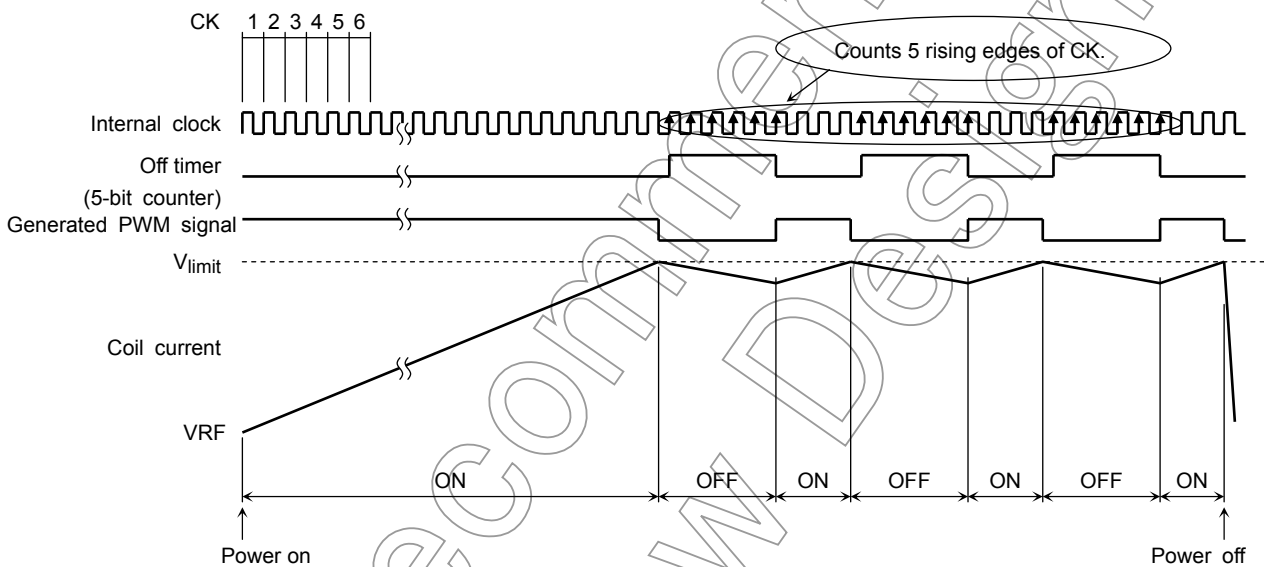

(The upper limit of the coil current (IO peak) can be calculated as:  $I_O = V_{limit}/R_{NF}$ .)

- Input Pins

All input pins (CK, DATA, LD, PWMA-PWME, STBY) have a pull-down resistor of about 200 kΩ.

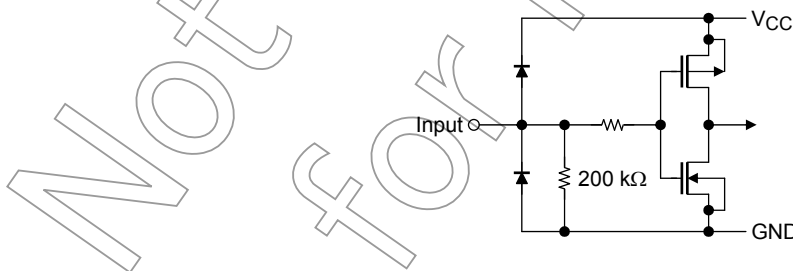

## Serial Data Format:

10-Bit Serial Data (MSB first)

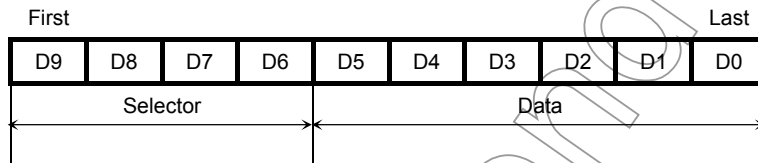
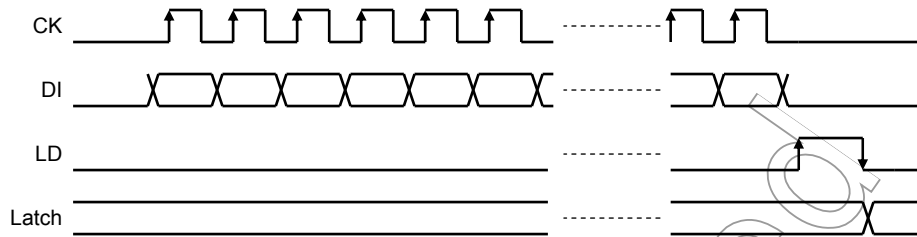

D9	D8	D7	D6	D5	D4	D3	D2	D1	D0	Address		
0	0	0	0	p2a	p2b	p1a	p1b	—	—	0		
0	0	0	1	mod2	mod1	pm2	pm1	—	—	1		
0	0	1	0	mod3	pm3	p3a	p3b	—	—	2		
0	0	1	1	p5a	p5b	p4a	p4b	off5	off4	3		
0	1	0	0	mod5	mod4	pm5	pm4	—	—	4		
0	1	0	1	DA1 (6 bits): Sets the current level for channel D						—	—	5
0	1	1	0	DA2 (6 bits): Sets the current level for channel E						—	—	6

Turn-off period settings (2 modes)

off4: Selects the chopper turn-off period for channel D (0 = 5 CLK cycles/1 = 3 CLK cycles)

off5: Selects the chopper turn-off period for channel E (0 = 5 CLK cycles/1 = 3 CLK cycles)

**DA values: The D5-D0 field specifies the current levels for DA1 and DA2 outputs in 64 steps**

D5	D4	D3	D2	D1	D0	Value
0	0	0	0	0	0	0
0	0	0	0	0	1	1
0	0	0	0	1	0	2
0	0	0	0	1	1	3
0	0	0	1	0	0	4
⋮	⋮	⋮	⋮	⋮	⋮	⋮
⋮	⋮	⋮	⋮	⋮	⋮	⋮
1	1	1	1	0	1	61
1	1	1	1	1	0	62
1	1	1	1	1	1	63

## Driver Operating Modes:

The pxa, pxb, modx and pmx bits determine the driver operating mode, as shown below:

### modx = 0, pmx = 0

pxa	pxb	IC Pins			Mode
		PWMx	OutxA	OutxB	
0	0	X	Z	Z	Stop
0	1	L	L	L	Short brake
0	1	H	L	H	Reverse
1	0	L	L	L	Short brake
1	0	H	H	L	Forward
1	1	X	L	L	Short brake

### modx = 0, pmx = 1

pxa	pxb	IC Pins			Mode
		PWMx	OutxA	OutxB	
0	0	X	Z	Z	Stop
0	1	L	L	H	Reverse
0	1	H	L	L	Short brake
1	0	L	H	L	Forward
1	0	H	L	L	Short brake
1	1	X	L	L	Short brake

### modx = 1, pmx = X

pxa	pxb	IC Pins			Mode
		PWMx	OutxA	OutxB	
0	X	X	Z	Z	Stop
1	0	L	H	L	Forward
1	0	H	L	H	Reverse
1	1	X	L	L	Short brake

X = Don't care

**Electrical Characteristics (unless otherwise specified, Ta = 25°C, VCC = 3.0 V, VM = 5 V)**

Characteristics		Symbol	Test Condition	Min.	Typ.	Max.	Unit
Supply current		ICC	All 5 channels in Forward mode	—	1	2	mA
		ICC (STB)	Standby mode (STBY = 0 V)	—	0.1	10	μA
		IM (STB)		—	0	1	
Serial, STBY and PWM inputs	Input voltage	VINH		VCC - 0.8	—	VCC + 0.2	V
		VINL		-0.2	—	0.4	
	Input current	IINH	VIH = 3 V	5	15	25	μA
		IINL	VIL = 0 V	—	—	1	
Output saturation voltage (Channels A to E)		Vsat (U+L)	IO = 0.2 A	—	0.3	0.4	V
			IO = 0.6 A	—	0.9	1.2	
Output leakage current (Channels A to E)		IL (U)	VM = 6 V	—	—	1	μA
		IL (L)		—	—	1	
Output diode forward voltage		VF (U)	IF = 0.6 A (Design target only)	—	1	—	V
		VF (L)		—	1	—	
Internal reference voltage		Vref		0.28	0.305	0.33	V
6-bit DAC	Nonlinearity	LB	Channels D and E	-3	—	3	LSB
	Differential linearity error	DLB		-2	—	2	
Oscillator	Oscillation frequency	fosc	COSC = 270 pF	392	560	728	kHz
Thermal shutdown threshold		TSD	(Design target only.)	—	170	—	°C
Thermal shutdown hysteresis		ΔTSD		—	20	—	

Not Recommended for New Design



## QON Package Considerations

### Package Appearances

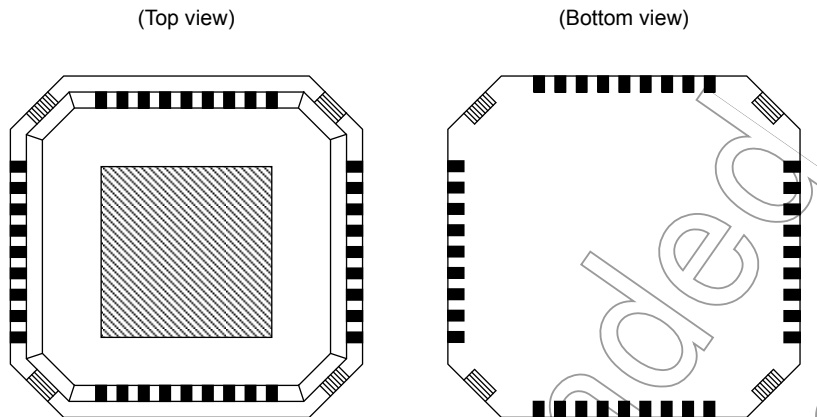

Please follow the following guidelines for the QON package.

#### Guidelines:

- (1) The solder plated pads at the four corners of the package (shaded areas in the bottom view) should not be soldered for the purpose of improving the mechanical strength of solder joints.
- (2) When using the TB6607FLG, it should be ensured that the thermal pad and solder plated pads (shaded areas in the top and bottom views) are electrically insulated (Note).

Note: Care should be taken in the board design to prevent solder for through-hole joints from flowing to the solder plated pads on the bottom of the package (shaded areas in the bottom view).

- When mounting or soldering this package, care must be taken to avoid electrostatic discharge or electrical overstress to the IC. (This is to avoid electrical leakage and a buildup of electrostatic charge in the end product.)
- It should be ensured that no voltage is directly applied to the solder plated pads when designing the PC board.

Top View Image

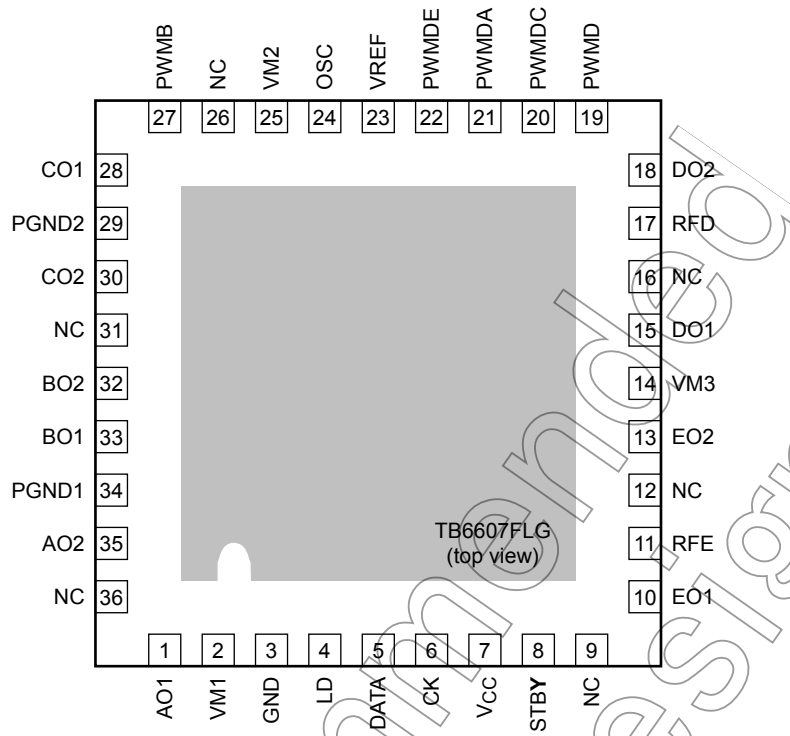

Not Recommended for New Design

**Package Dimensions**

QON36-P-0606-0.50

Unit: mm

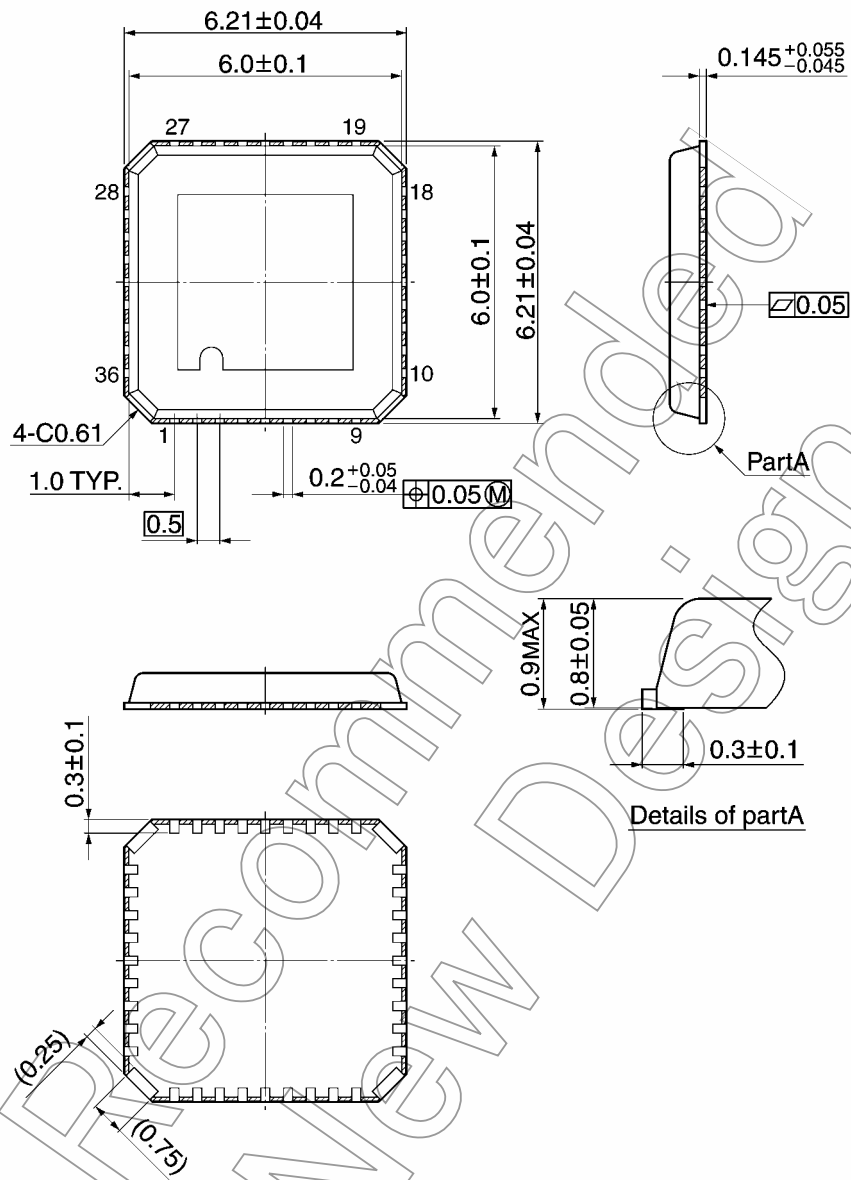

Note 1) The solder plating portion in four corners of the package shall not be treated as an external terminal.

Note 2) Don't carry out soldering to four corners of the package.

Note 3)  area : Resin surface

Weight: 0.08 g (typ.)

## Notes on Contents

### 1. Block Diagrams

Some of the functional blocks, circuits, or constants in the block diagram may be omitted or simplified for explanatory purposes.

### 2. Equivalent Circuits

The equivalent circuit diagrams may be simplified or some parts of them may be omitted for explanatory purposes.

### 3. Timing Charts

Timing charts may be simplified for explanatory purposes.

### 4. Application Circuits

The application circuits shown in this document are provided for reference purposes only. Thorough evaluation is required, especially at the mass production design stage. Toshiba does not grant any license to any industrial property rights by providing these examples of application circuits.

### 5. Test Circuits

Components in the test circuits are used only to obtain and confirm the device characteristics. These components and circuits are not guaranteed to prevent malfunction or failure from occurring in the application equipment.

## IC Usage Considerations

### Notes on handling of ICs

- (1) The absolute maximum ratings of a semiconductor device are a set of ratings that must not be exceeded, even for a moment. Do not exceed any of these ratings. Exceeding the rating(s) may cause the device breakdown, damage or deterioration, and may result injury by explosion or combustion.
- (2) Use an appropriate power supply fuse to ensure that a large current does not continuously flow in case of over current and/or IC failure. The IC will fully break down when used under conditions that exceed its absolute maximum ratings, when the wiring is routed improperly or when an abnormal pulse noise occurs from the wiring or load, causing a large current to continuously flow and the breakdown can lead smoke or ignition. To minimize the effects of the flow of a large current in case of breakdown, appropriate settings, such as fuse capacity, fusing time and insertion circuit location, are required.
- (3) If your design includes an inductive load such as a motor coil, incorporate a protection circuit into the design to prevent device malfunction or breakdown caused by the current resulting from the inrush current at power ON or the negative current resulting from the back electromotive force at power OFF. IC breakdown may cause injury, smoke or ignition. Use a stable power supply with ICs with built-in protection functions. If the power supply is unstable, the protection function may not operate, causing IC breakdown. IC breakdown may cause injury, smoke or ignition.
- (4) Do not insert devices in the wrong orientation or incorrectly. Make sure that the positive and negative terminals of power supplies are connected properly. Otherwise, the current or power consumption may exceed the absolute maximum rating, and exceeding the rating(s) may cause the device breakdown, damage or deterioration, and may result injury by explosion or combustion. In addition, do not use any device that is applied the current with inserting in the wrong orientation or incorrectly even just one time.

## Points to remember on handling of ICs

(1) Over current Protection Circuit

Over current protection circuits (referred to as current limiter circuits) do not necessarily protect ICs under all circumstances. If the Over current protection circuits operate against the over current, clear the over current status immediately.

Depending on the method of use and usage conditions, such as exceeding absolute maximum ratings can cause the over current protection circuit to not operate properly or IC breakdown before operation. In addition, depending on the method of use and usage conditions, if over current continues to flow for a long time after operation, the IC may generate heat resulting in breakdown.

(2) Heat Radiation Design

In using an IC with large current flow such as power amp, regulator or driver, please design the device so that heat is appropriately radiated, not to exceed the specified junction temperature ( $T_j$ ) at any time and condition. These ICs generate heat even during normal use. An inadequate IC heat radiation design can lead to decrease in IC life, deterioration of IC characteristics or IC breakdown. In addition, please design the device taking into considerate the effect of IC heat radiation with peripheral components.

(3) Back-EMF

When a motor rotates in the reverse direction, stops or slows down abruptly, a current flow back to the motor's power supply due to the effect of back-EMF. If the current sink capability of the power supply is small, the device's motor power supply and output pins might be exposed to conditions beyond maximum ratings. To avoid this problem, take the effect of back-EMF into consideration in system design.

Not Recommended for New Design

**RESTRICTIONS ON PRODUCT USE**

070122EBA\_R6

- The information contained herein is subject to change without notice. 021023\_D
- TOSHIBA is continually working to improve the quality and reliability of its products. Nevertheless, semiconductor devices in general can malfunction or fail due to their inherent electrical sensitivity and vulnerability to physical stress. It is the responsibility of the buyer, when utilizing TOSHIBA products, to comply with the standards of safety in making a safe design for the entire system, and to avoid situations in which a malfunction or failure of such TOSHIBA products could cause loss of human life, bodily injury or damage to property.  
In developing your designs, please ensure that TOSHIBA products are used within specified operating ranges as set forth in the most recent TOSHIBA products specifications. Also, please keep in mind the precautions and conditions set forth in the "Handling Guide for Semiconductor Devices," or "TOSHIBA Semiconductor Reliability Handbook" etc. 021023\_A
- The TOSHIBA products listed in this document are intended for usage in general electronics applications (computer, personal equipment, office equipment, measuring equipment, industrial robotics, domestic appliances, etc.). These TOSHIBA products are neither intended nor warranted for usage in equipment that requires extraordinarily high quality and/or reliability or a malfunction or failure of which may cause loss of human life or bodily injury ("Unintended Usage"). Unintended Usage include atomic energy control instruments, airplane or spaceship instruments, transportation instruments, traffic signal instruments, combustion control instruments, medical instruments, all types of safety devices, etc. Unintended Usage of TOSHIBA products listed in this document shall be made at the customer's own risk. 021023\_B
- The products described in this document shall not be used or embedded to any downstream products of which manufacture, use and/or sale are prohibited under any applicable laws and regulations. 060106\_Q
- The information contained herein is presented only as a guide for the applications of our products. No responsibility is assumed by TOSHIBA for any infringements of patents or other rights of the third parties which may result from its use. No license is granted by implication or otherwise under any patents or other rights of TOSHIBA or the third parties. 070122\_C
- Please use this product in compliance with all applicable laws and regulations that regulate the inclusion or use of controlled substances.  
Toshiba assumes no liability for damage or losses occurring as a result of noncompliance with applicable laws and regulations. 060819\_AF
- The products described in this document are subject to foreign exchange and foreign trade control laws. 060925\_E

## Looking for pricing, stock, or lifecycle information?

Click below to explore more details on WIN SOURCE:

- [View TB6607FLG\(O,EL\) on WIN SOURCE](#)
- [Toshiba Semiconductor and Storage Information](#)

## Optimize Your Supply Chain with WIN SOURCE Solutions

- ✓ Global Sourcing Solution
- ✓ Obsolete Management
- ✓ Cost Control Management
- ✓ Shortage Management
- ✓ Alternative Solution
- ✓ Excess Inventory Management