

Toshiba Bi-CD Integrated Circuit Silicon Monolithic

TB6593FNG

Driver IC for DC motor

TB6593FNG is a driver IC for DC motor with output transistor in LD MOS structure with low ON-resistor. Two input signals, IN1 and IN2, can choose one of four modes such as CW, CCW, short break, and stop mode.

Features

- Power supply voltage : $V_M = 15\text{ V}$ (Max)
- Output current : $I_{out} = 1.2\text{ A}$ (ave)/ 3.2 A (peak)
- Output low ON resistor : $0.35\ \Omega$ ((typ. @ $V_M \geq 5\text{ V}$)
- Standby (Power save)system
- CW/CCW/short break/stop function modes
- Built-in thermal shutdown circuit and low voltage detecting circuit
- Small faced package (SSOP20:0.65 mm pitch)
- RoHS compatible

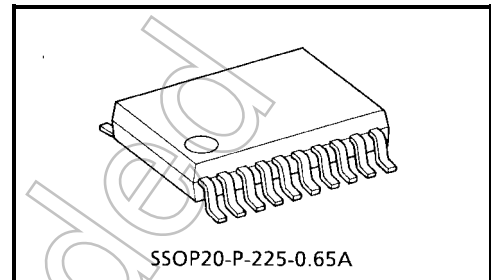

SSOP20-P-225-0.65A

Weight: 0.09 g (typ.)

* This product has a MOS structure and is sensitive to electrostatic discharge. When handling this product, ensure that the environment is protected against electrostatic discharge by using an earth strap, a conductive mat and an ionizer. Ensure also that the ambient temperature and relative humidity are maintained at reasonable levels.

Block Diagram

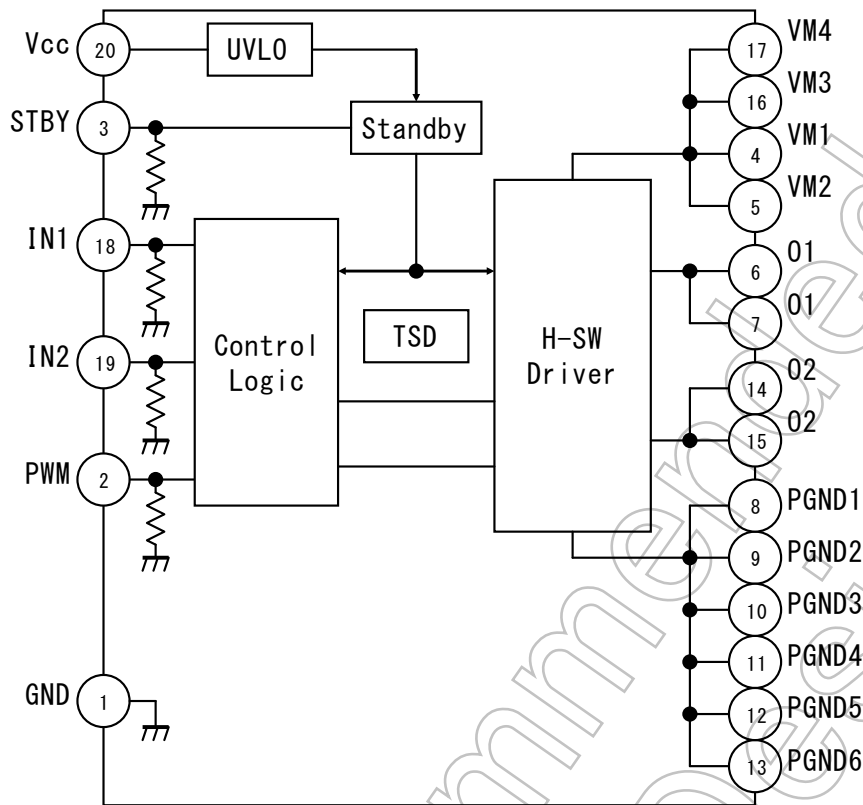

Pin Functions

Pin NO.	Symbol	Characteristics	Remarks
1	GND	Small signal GND	
2	PWM	PWM signal input	"H" = Active/200 kΩ pull-down at internal
3	STBY	Standby signal input	"L" = Standby/200 kΩ pull-down at internal
4	VM1	VM supply	VM = 2.5 V to 13.5 V
5	VM2		
6	O1	Output1	
7	O1		
8	PGND1	Power GND	
9	PGND2		
10	PGND3		
11	PGND4		
12	PGND5		
13	PGND6		
14	O2	Output2	
15	O2		
16	VM3	VM supply	VM = 2.5 V to 13.5 V
17	VM4		
18	IN1	Control signal input 1	200 kΩ pull-down at internal
19	IN2	Control signal input 2	
20	Vcc	Small signal supply	Vcc = 2.7 V to 5.5 V

Absolute Maximum Ratings (Ta = 25°C)

Characteristics	Symbol	Rating	Unit	Remarks
Supply voltage	VM	15	V	
	Vcc	6		
Input voltage	VIN	-0.2 to 6	V	IN1,IN2,STBY,PWM pins
Output voltage	Vout	15	V	O1,O2 pins
Output current	Iout	1.2	A	
	Iout (peak)	3.2		tw = 10 ms, Superimposed pulse, Duty is 20 % or less.
		4.5		tw = 10 ms, Single pulse
Power dissipation	PD	1.18	W	76.2 mm × 114.3 mm × 1.6 mm When it is packaged to the board made of glass-epoxy (Cu 30 %).
		0.96		50 mm × 50 mm × 1.6 mm When it is packaged to the board made of glass-epoxy (Cu 40 %).
		0.71		IC only
Operating temperature	Topr	-20 to 85	°C	
Storage temperature	Tstg	-55 to 150	°C	

Operating Ranges (Ta = -20 to 85°C)

Characteristics	Symbol	Min	Typ.	Max	Unit
Supply voltage	Vcc	2.7	3	5.5	V
	VM	2.5	5	13.5	V
Output current (H-SW)	Iout	—	—	1.0	A
Switching frequency	fPWM	—	—	100	kHz

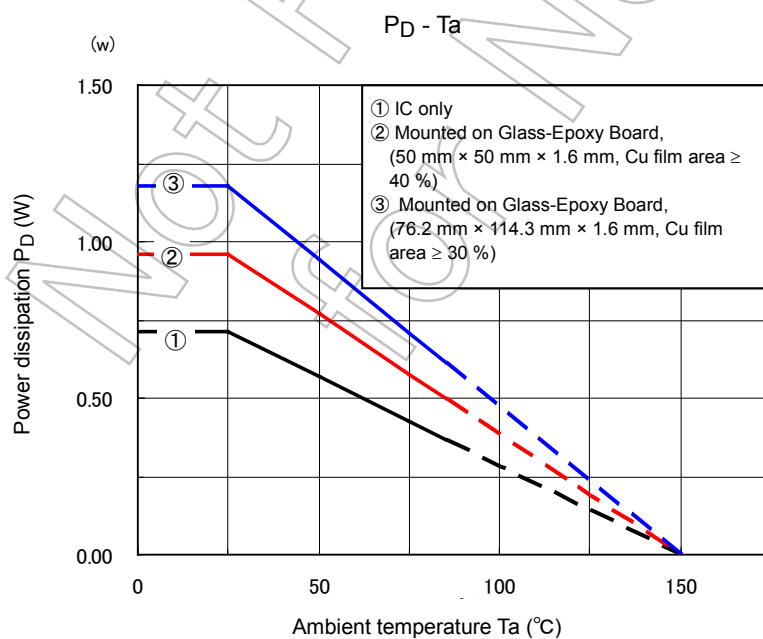

H-SW Control Function

Input				Output		
IN1	IN2	PWM	STBY	OUT1	OUT2	Mode
H	H	H/L	H	L	L	Short break
L	H	H	H	L	H	CCW
		L	H	L	L	Short break
H	L	H	H	H	L	CW
		L	H	L	L	Short break
L	L	H/L	H	OFF (High impedance)		Stop
H/L	H/L	H/L	L	OFF (High impedance)		Standby

H-SW Operating Description

• To prevent penetrating current, dead time t_2 and t_4 (300 ns: Designed value) is provided in switching to each mode in the IC.

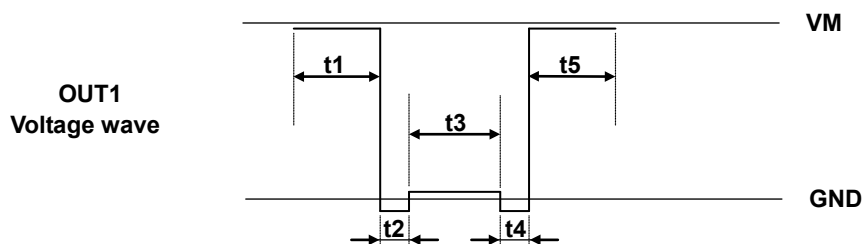
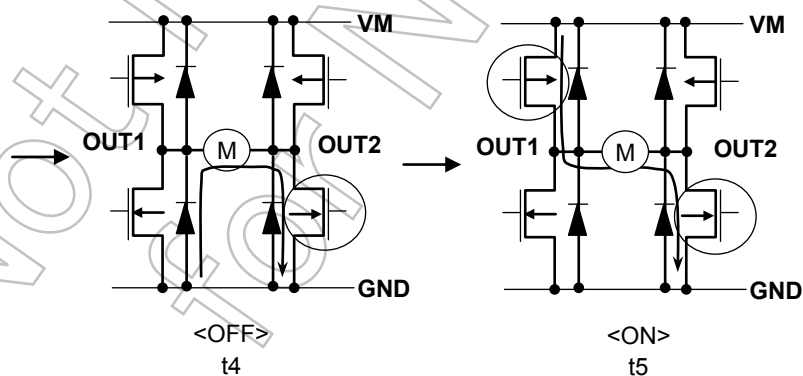
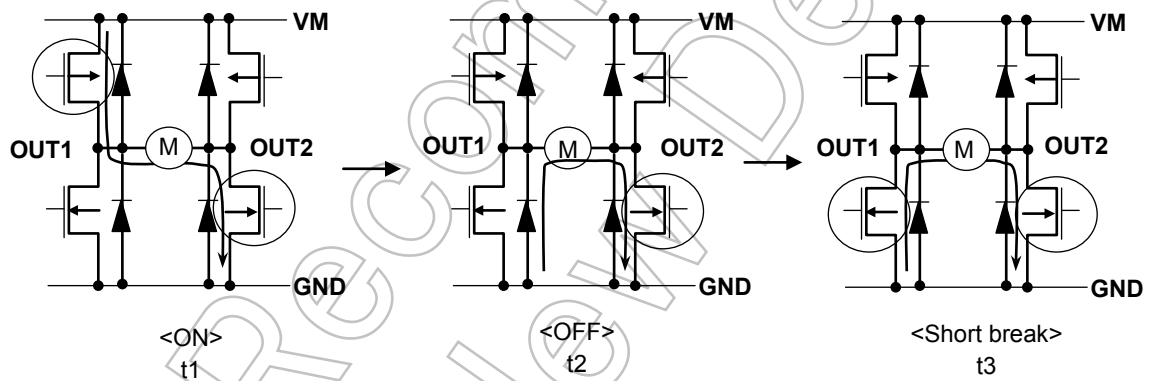

Electrical Characteristics (unless otherwise specified, Vcc = 3 V, VM = 5 V, Ta = 25°C)

Characteristics	Symbol	Test Condition	Min	Typ.	Max	Unit
Supply current	Icc	STBY = Vcc	—	0.9	1.2	mA
	Icc(STB)	STBY = 0 V	—	—	1	μA
	IM(STB)		—	—	1	
Control input voltage	VIH		2	—	Vcc+0.2	V
	VIL		-0.2	—	0.8	
Control input current	IIH	VIN = 3 V	5	15	25	μA
	IIL	VIN = 0 V	—	—	1	
Standby input voltage	VIH(STB)		2	—	Vcc+0.2	V
	VIL(STB)		-0.2	—	0.8	
Standby input current	IIH(STB)	VIN = 3 V	5	15	25	μA
	IIL(STB)	VIN = 0 V	—	—	1	
Output saturating voltage	Vsat(U+L)	Io = 1 A	—	0.35	0.5	V
Output leakage current	IL(U)	VM = Vout = 15 V	—	—	1	μA
	IL(L)	VM = 15 V, Vout = 0 V	-1	—	—	
Regenerative diode VF	VF(U)	IF = 1 A	—	1	1.1	V
	VF(L)		—	1	1.1	
Low voltage detecting voltage	UVLD	(Designed value)	—	2.0	—	V
Recovering voltage	UVLC		—	2.2	—	
Thermal shutdown circuit operating temperature	TSD	(Designed value)	—	170	—	°C
Thermal shutdown hysteresis	ΔTSD		—	20	—	

Not Recommended for New Design

Typical Application Diagram

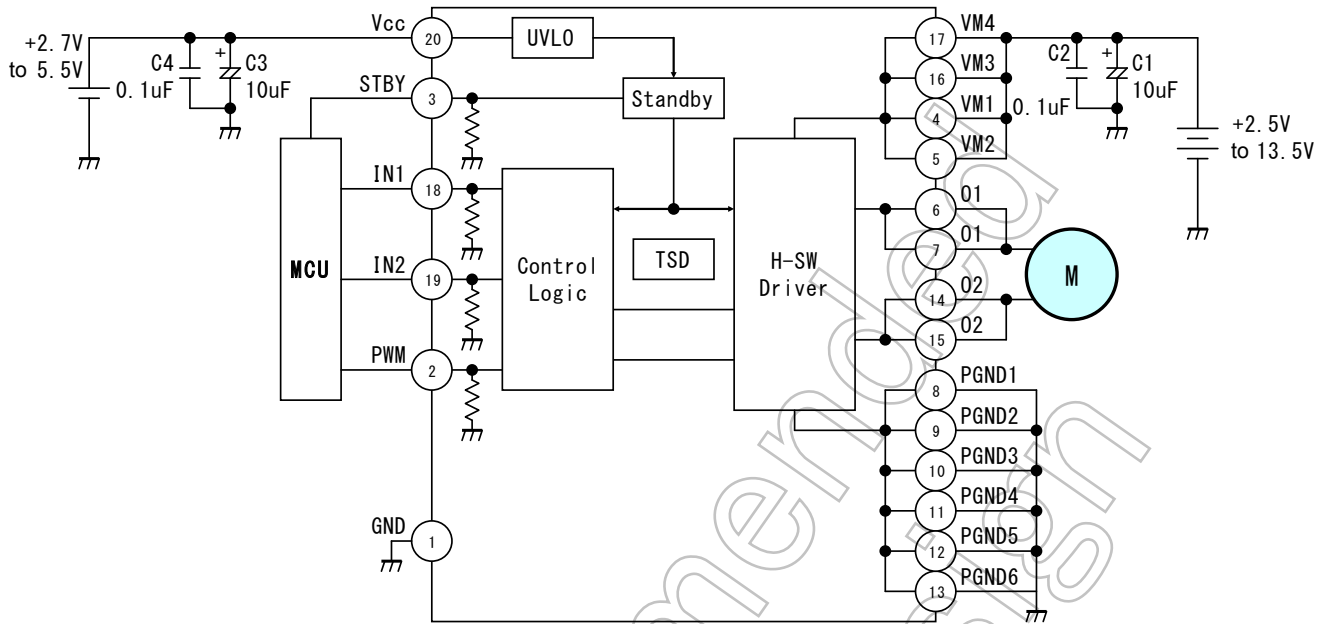

Note: Bypass capacitors (C1, C2, C3, and C4) should be connected as close as possible to the IC.

Not Recommended for New Design

Package Dimensions

SSOP20-P-225-0.65A

Unit : mm

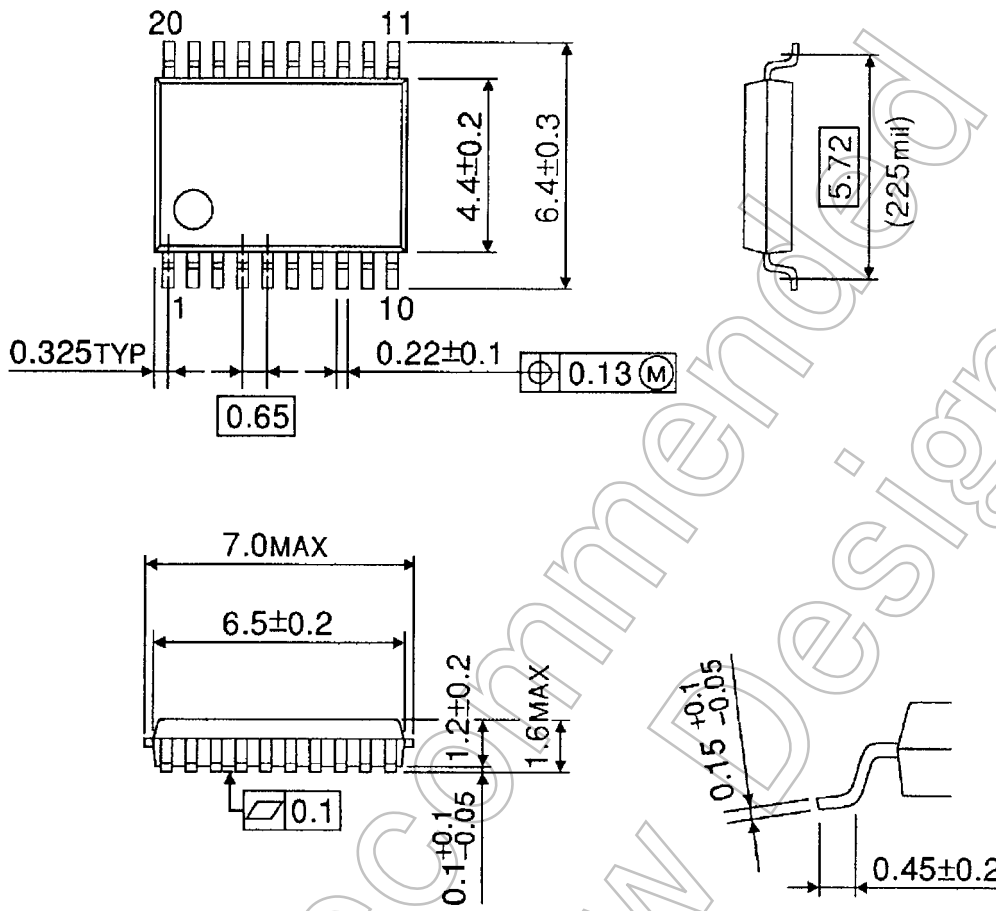

Weight: 0.09 g (Typ.)

Not Recommended for New Design

Notes on Contents**1. Block Diagrams**

Some of the functional blocks, circuits, or constants in the block diagram may be omitted or simplified for explanatory purposes.

2. Equivalent Circuits

The equivalent circuit diagrams may be simplified or some parts of them may be omitted for explanatory purposes.

3. Timing Charts

Timing charts may be simplified for explanatory purposes.

4. Application Circuits

The application circuits shown in this document are provided for reference purposes only. Thorough evaluation is required, especially at the mass production design stage.

Toshiba does not grant any license to any industrial property rights by providing these examples of application circuits.

5. Test Circuits

Components in the test circuits are used only to obtain and confirm the device characteristics. These components and circuits are not guaranteed to prevent malfunction or failure from occurring in the application equipment.

IC Usage Considerations**Notes on handling of ICs**

- [1] The absolute maximum ratings of a semiconductor device are a set of ratings that must not be exceeded, even for a moment. Do not exceed any of these ratings.
Exceeding the rating(s) may cause the device breakdown, damage or deterioration, and may result injury by explosion or combustion.
- [2] Use an appropriate power supply fuse to ensure that a large current does not continuously flow in case of over current and/or IC failure. The IC will fully break down when used under conditions that exceed its absolute maximum ratings, when the wiring is routed improperly or when an abnormal pulse noise occurs from the wiring or load, causing a large current to continuously flow and the breakdown can lead smoke or ignition. To minimize the effects of the flow of a large current in case of breakdown, appropriate settings, such as fuse capacity, fusing time and insertion circuit location, are required.
- [3] If your design includes an inductive load such as a motor coil, incorporate a protection circuit into the design to prevent device malfunction or breakdown caused by the current resulting from the inrush current at power ON or the negative current resulting from the back electromotive force at power OFF. IC breakdown may cause injury, smoke or ignition.
Use a stable power supply with ICs with built-in protection functions. If the power supply is unstable, the protection function may not operate, causing IC breakdown. IC breakdown may cause injury, smoke or ignition.
- [4] Do not insert devices in the wrong orientation or incorrectly.
Make sure that the positive and negative terminals of power supplies are connected properly.
Otherwise, the current or power consumption may exceed the absolute maximum rating, and exceeding the rating(s) may cause the device breakdown, damage or deterioration, and may result injury by explosion or combustion.
In addition, do not use any device that is applied the current with inserting in the wrong orientation or incorrectly even just one time.

Points to remember on handling of ICs**(1) Thermal Shutdown Circuit**

Thermal shutdown circuits do not necessarily protect ICs under all circumstances. If the thermal shutdown circuits operate against the over temperature, clear the heat generation status immediately.

Depending on the method of use and usage conditions, such as exceeding absolute maximum ratings can cause the thermal shutdown circuit to not operate properly or IC breakdown before operation.

(2) Heat Radiation Design

In using an IC with large current flow such as power amp, regulator or driver, please design the device so that heat is appropriately radiated, not to exceed the specified junction temperature (T_J) at any time and condition. These ICs generate heat even during normal use. An inadequate IC heat radiation design can lead to decrease in IC life, deterioration of IC characteristics or IC breakdown. In addition, please design the device taking into consideration the effect of IC heat radiation with peripheral components.

(3) Back-EMF

When a motor rotates in the reverse direction, stops or slows down abruptly, a current flow back to the motor's power supply due to the effect of back-EMF. If the current sink capability of the power supply is small, the device's motor power supply and output pins might be exposed to conditions beyond maximum ratings. To avoid this problem, take the effect of back-EMF into consideration in system design.

Not Recommended for New Design

RESTRICTIONS ON PRODUCT USE

- Toshiba Corporation, and its subsidiaries and affiliates (collectively "TOSHIBA"), reserve the right to make changes to the information in this document, and related hardware, software and systems (collectively "Product") without notice.
- This document and any information herein may not be reproduced without prior written permission from TOSHIBA. Even with TOSHIBA's written permission, reproduction is permissible only if reproduction is without alteration/omission.
- Though TOSHIBA works continually to improve Product's quality and reliability, Product can malfunction or fail. Customers are responsible for complying with safety standards and for providing adequate designs and safeguards for their hardware, software and systems which minimize risk and avoid situations in which a malfunction or failure of Product could cause loss of human life, bodily injury or damage to property, including data loss or corruption. Before customers use the Product, create designs including the Product, or incorporate the Product into their own applications, customers must also refer to and comply with (a) the latest versions of all relevant TOSHIBA information, including without limitation, this document, the specifications, the data sheets and application notes for Product and the precautions and conditions set forth in the "TOSHIBA Semiconductor Reliability Handbook" and (b) the instructions for the application with which the Product will be used with or for. Customers are solely responsible for all aspects of their own product design or applications, including but not limited to (a) determining the appropriateness of the use of this Product in such design or applications; (b) evaluating and determining the applicability of any information contained in this document, or in charts, diagrams, programs, algorithms, sample application circuits, or any other referenced documents; and (c) validating all operating parameters for such designs and applications. **TOSHIBA ASSUMES NO LIABILITY FOR CUSTOMERS' PRODUCT DESIGN OR APPLICATIONS.**
- **PRODUCT IS NEITHER INTENDED NOR WARRANTED FOR USE IN EQUIPMENTS OR SYSTEMS THAT REQUIRE EXTRAORDINARILY HIGH LEVELS OF QUALITY AND/OR RELIABILITY, AND/OR A MALFUNCTION OR FAILURE OF WHICH MAY CAUSE LOSS OF HUMAN LIFE, BODILY INJURY, SERIOUS PROPERTY DAMAGE AND/OR SERIOUS PUBLIC IMPACT ("UNINTENDED USE").** Except for specific applications as expressly stated in this document, Unintended Use includes, without limitation, equipment used in nuclear facilities, equipment used in the aerospace industry, medical equipment, equipment used for automobiles, trains, ships and other transportation, traffic signaling equipment, equipment used to control combustions or explosions, safety devices, elevators and escalators, devices related to electric power, and equipment used in finance-related fields. **IF YOU USE PRODUCT FOR UNINTENDED USE, TOSHIBA ASSUMES NO LIABILITY FOR PRODUCT.** For details, please contact your TOSHIBA sales representative.
- Do not disassemble, analyze, reverse-engineer, alter, modify, translate or copy Product, whether in whole or in part.
- Product shall not be used for or incorporated into any products or systems whose manufacture, use, or sale is prohibited under any applicable laws or regulations.
- The information contained herein is presented only as guidance for Product use. No responsibility is assumed by TOSHIBA for any infringement of patents or any other intellectual property rights of third parties that may result from the use of Product. No license to any intellectual property right is granted by this document, whether express or implied, by estoppel or otherwise.
- **ABSENT A WRITTEN SIGNED AGREEMENT, EXCEPT AS PROVIDED IN THE RELEVANT TERMS AND CONDITIONS OF SALE FOR PRODUCT, AND TO THE MAXIMUM EXTENT ALLOWABLE BY LAW, TOSHIBA (1) ASSUMES NO LIABILITY WHATSOEVER, INCLUDING WITHOUT LIMITATION, INDIRECT, CONSEQUENTIAL, SPECIAL, OR INCIDENTAL DAMAGES OR LOSS, INCLUDING WITHOUT LIMITATION, LOSS OF PROFITS, LOSS OF OPPORTUNITIES, BUSINESS INTERRUPTION AND LOSS OF DATA, AND (2) DISCLAIMS ANY AND ALL EXPRESS OR IMPLIED WARRANTIES AND CONDITIONS RELATED TO SALE, USE OF PRODUCT, OR INFORMATION, INCLUDING WARRANTIES OR CONDITIONS OF MERCHANTABILITY, FITNESS FOR A PARTICULAR PURPOSE, ACCURACY OF INFORMATION, OR NONINFRINGEMENT.**
- Do not use or otherwise make available Product or related software or technology for any military purposes, including without limitation, for the design, development, use, stockpiling or manufacturing of nuclear, chemical, or biological weapons or missile technology products (mass destruction weapons). Product and related software and technology may be controlled under the applicable export laws and regulations including, without limitation, the Japanese Foreign Exchange and Foreign Trade Law and the U.S. Export Administration Regulations. Export and re-export of Product or related software or technology are strictly prohibited except in compliance with all applicable export laws and regulations.
- Please contact your TOSHIBA sales representative for details as to environmental matters such as the RoHS compatibility of Product. Please use Product in compliance with all applicable laws and regulations that regulate the inclusion or use of controlled substances, including without limitation, the EU RoHS Directive. **TOSHIBA ASSUMES NO LIABILITY FOR DAMAGES OR LOSSES OCCURRING AS A RESULT OF NONCOMPLIANCE WITH APPLICABLE LAWS AND REGULATIONS.**

Looking for pricing, stock, or lifecycle information?

Click below to explore more details on WIN SOURCE:

- [View TB6593FNG\(O,EL\) on WIN SOURCE](#)
- [Toshiba Semiconductor and Storage Information](#)

Optimize Your Supply Chain with WIN SOURCE Solutions

- ✓ Global Sourcing Solution
- ✓ Obsolete Management
- ✓ Cost Control Management
- ✓ Shortage Management
- ✓ Alternative Solution
- ✓ Excess Inventory Management