

# TB6590FTG

## Dual DC Motor Driver

The TB6590FTG is a dual DC motor driver IC using LDMOS output transistors with low ON-resistance.

Four operation modes are selectable via IN1 and IN2: forward, reverse, short brake and stop.

### Features

- Power supply voltage:  $V_M = 6\text{ V}$  (max)
- Output current:  $I_{OUT} = 0.5\text{ A}$  (max)
- Output ON-resistance:  $2.5\ \Omega$   
(upper and lower sum (typ.) @  $V_M \geq 5\text{ V}$ )
- Dedicated standby (power-save) pin
- Forward, reverse, short brake and stop
- Thermal shutdown (TSD) and undervoltage lockout (UVLO) circuits
- Small surface-mount package (VQON16: 0.5-mm lead pitch)
- Lead(Pb)-free solderable

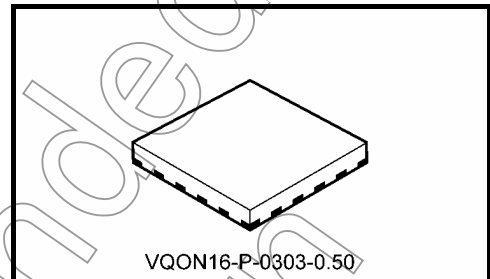

Weight: 0.01 g (typ.)

\*: This product has a MOS structure and is sensitive to electrostatic discharge. When handling this product, ensure that the environment is protected against electrostatic discharge by using an earth strap, a conductive mat and an ionizer. Ensure also that the ambient temperature and relative humidity are maintained at reasonable levels.

Not Recommended for New Designs

## Block Diagram

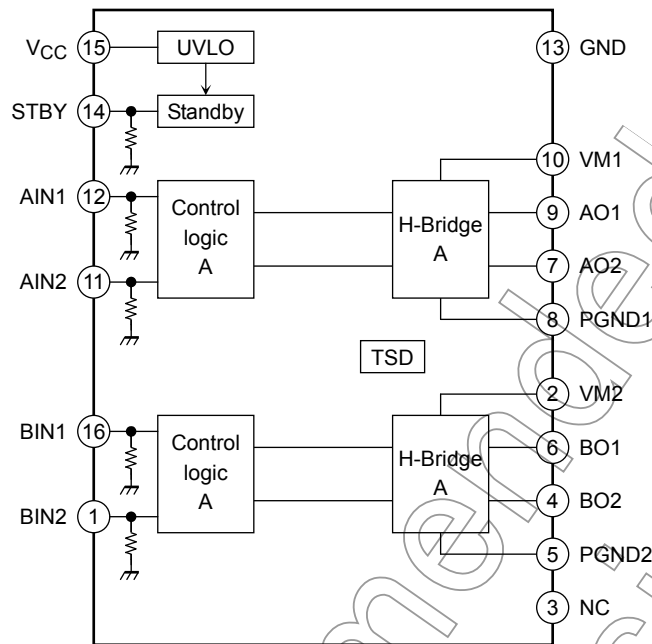

## Pin Functions

Pin No.	Symbol	Function	Remarks
1	BIN2	Channel-B input 2	<ul style="list-style-type: none"> <li>• TTL compatible</li> <li>• Internal pull-down resistor of 200 k<math>\Omega</math></li> </ul>
2	VM2	Motor power supply 2	$V_M = 2.2$ to $5.5$ V
3	NC	No connect	
4	BO2	Channel-B output 2	
5	PGND2	Power ground 2	
6	BO1	Channel-B output 1	
7	AO2	Channel-A output 2	
8	PGND1	Power ground 1	
9	AO1	Channel-A output 1	
10	VM1	Motor power supply 1	$V_M = 2.2$ to $5.5$ V
11	AIN2	Channel-A input 2	<ul style="list-style-type: none"> <li>• TTL compatible</li> <li>• Internal pull-down resistor of 200 k<math>\Omega</math></li> </ul>
12	AIN1	Channel-A input 1	<ul style="list-style-type: none"> <li>• TTL compatible</li> <li>• Internal pull-down resistor of 200 k<math>\Omega</math></li> </ul>
13	GND	Small signal ground	
14	STBY	Standby control input	L = standby; internal pull-down resistor of 200 k $\Omega$
15	VCC	VCC power supply pin	$V_{CC}$ (opr.) = 2.7 to 5.5 V
16	BIN1	Channel-B input 1	<ul style="list-style-type: none"> <li>• TTL compatible</li> <li>• Internal pull-down resistor of 200 k<math>\Omega</math></li> </ul>

## Absolute Maximum Ratings (Ta = 25°C)

Characteristics	Symbol	Rating	Unit	Remarks
Supply voltage	V <sub>M</sub>	6	V	
	V <sub>CC</sub>	6		
Input voltage	V <sub>IN</sub>	-0.2 to 6	V	AIN1, AIN2, BIN1, BIN2 and STBY pins
Output voltage	V <sub>OUT</sub>	6	V	AO1, AO2, BO1 and BO2 pins
Output current	I <sub>OUT</sub>	0.5	A	
Power dissipation	P <sub>D</sub>	0.275	W	(Note)
Operating temperature	T <sub>opr</sub>	-20 to 85	°C	
Storage temperature	T <sub>stg</sub>	-55 to 150	°C	

Note: The rated power dissipation should be derated by 2.2 mW/°C above 25°C ambient.

## Operating Ranges (Ta = -20 to 85°C)

Characteristics	Symbol	Min	Typ.	Max	Unit
Supply voltage	V <sub>CC</sub>	2.7	3	5.5	V
	V <sub>M</sub>	2.2	5	5.5	V
Output current	I <sub>OUT</sub>	-	-	0.4	A
PWM frequency	f <sub>PWM</sub>	-	-	200	kHz

Not Recommended for New Design

**Function Table for H-Bridge Control**

Input			Output		Function Mode
IN1	IN2	STBY	OUT1	OUT2	
H	H	H	L	L	Short brake
L	H	H	L	H	CCW
H	L	H	H	L	CW
L	L	H	OFF (high impedance)		Stop
H/L	H/L	L	OFF (high impedance)		Standby

**Functional Description of H-Bridge Driver**

To eliminate shoot-through current, a dead time ( $t_2, t_4$ ) is inserted when the PWM is turned on and off.

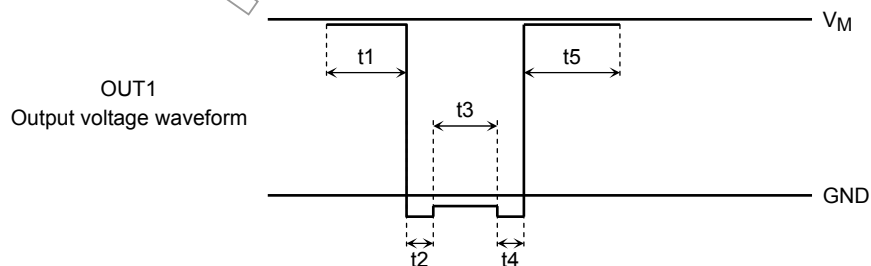
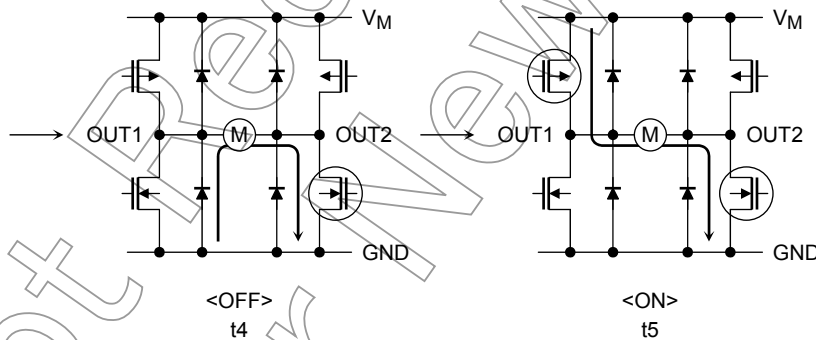
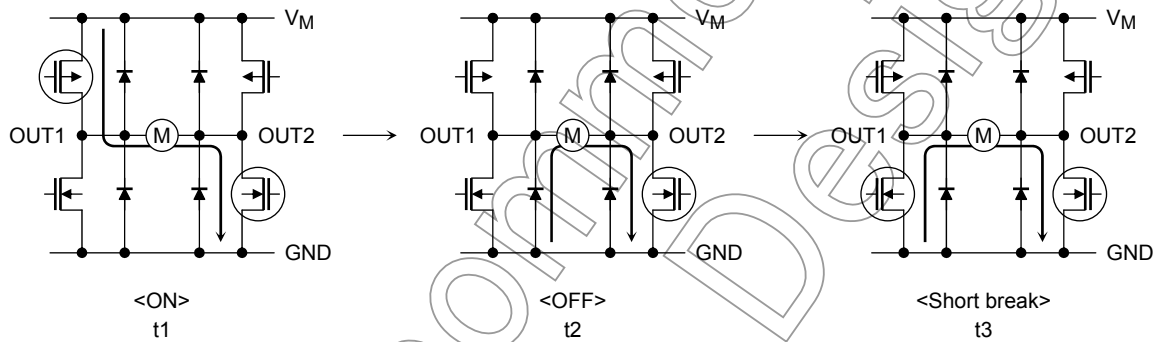

## Electrical Characteristics (unless otherwise specified, $T_a = 25^\circ\text{C}$ , $V_{CC} = 3\text{ V}$ , $V_M = 5\text{ V}$ )

Characteristics	Symbol	Test Condition	Min	Typ.	Max	Unit
Supply current	$I_{CC}$	STBY = $V_{CC}$	—	0.3	0.6	mA
	$I_{CC}(\text{STB})$	STBY = 0 V	—	—	10	$\mu\text{A}$
	$I_M(\text{STB})$		—	—	1	
Control input voltage	$V_{IH}$		2	—	$V_{CC} + 0.2$	V
	$V_{IL}$		-0.2	—	0.8	
Control input current	$I_{IH}$	$V_{IN} = 3\text{ V}$	5	15	25	$\mu\text{A}$
	$I_{IL}$	$V_{IN} = 0\text{ V}$	—	—	1	
Standby input voltage	$V_{IH}(\text{STB})$		2	—	$V_{CC} + 0.2$	V
	$V_{IL}(\text{STB})$		-0.2	—	0.8	
Standby input current	$I_{IH}(\text{STB})$	$V_{IN} = 3\text{ V}$	5	15	25	$\mu\text{A}$
	$I_{IL}(\text{STB})$	$V_{IN} = 0\text{ V}$	—	—	1	
Output saturation voltage	$V_{\text{sat}}(U + L)$	$I_O = 0.2\text{ A}$	—	0.5	0.7	V
Output leakage current	$I_L(U)$	$V_M = V_{\text{OUT}} = 6\text{ V}$	—	—	1	$\mu\text{A}$
	$I_L(L)$	$V_M = 6\text{ V}, V_{\text{OUT}} = 0\text{ V}$	-1	—	—	
Forward voltage of a regenerative diode	$V_F(U)$	$I_F = 0.4\text{ A}$ (Design target only)	—	0.9	—	V
	$V_F(L)$		—	0.9	—	
Undervoltage lockout trip threshold	UVLD	(Design target only)	—	2.2	—	V
Undervoltage lockout recovery	UVLC		—	2.4	—	V
Thermal shutdown threshold	TSD	(Design target only)	—	170	—	$^\circ\text{C}$
Thermal shutdown hysteresis	$\Delta\text{TSD}$		—	20	—	$^\circ\text{C}$
Output transistor switching characteristics	$t_r$	$R_L = 100\ \Omega$ (Design target only)	—	10	—	ns
	$t_f$		—	10	—	
	$t_{PLH}$		—	50	—	
	$t_{PHL}$		—	50	—	
Dead time for shoot-through prevention	$t_{\text{dead}}$	(Design target only)	—	100	—	ns

**Application Circuit Example**

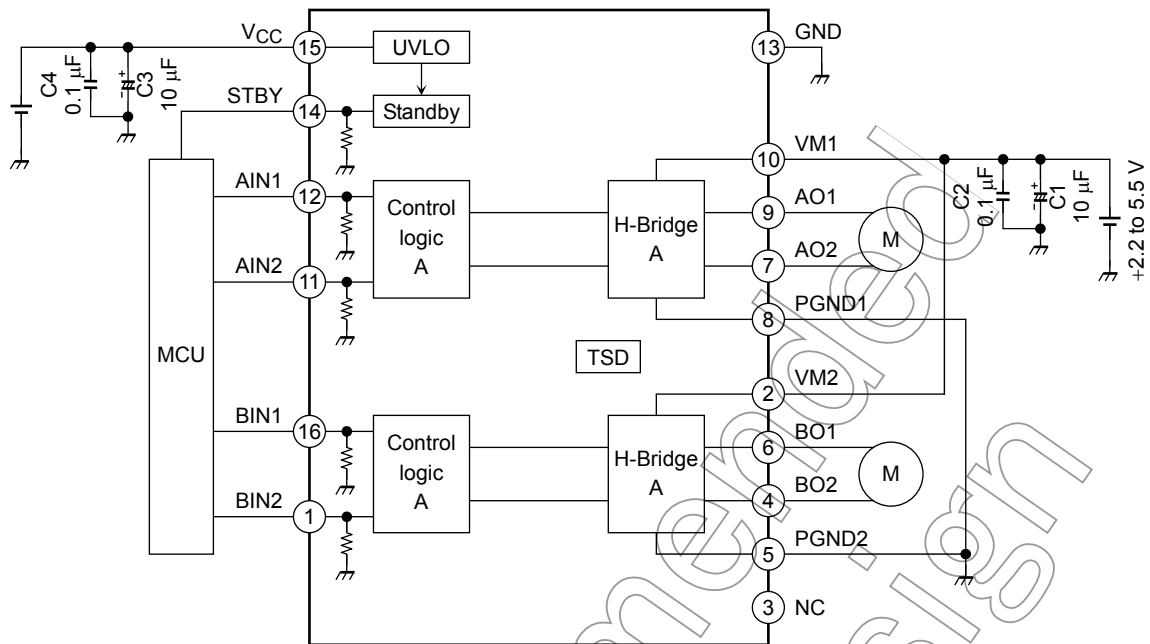

Note 1: Bypass capacitors (C1, C2, C3 and C4) should be placed as close as possible to the IC.

Note 2: Excessive power might be introduced into the IC in case of a short-circuit between power supply and ground, an output short-circuit to power supply, an output short-circuit to ground or a short-circuit across the load. If any of these events occur, the device may be degraded or permanently damaged.

Not Recommended for New Design

**Package Dimensions**

VQON16-P-0303-0.50

Unit: mm

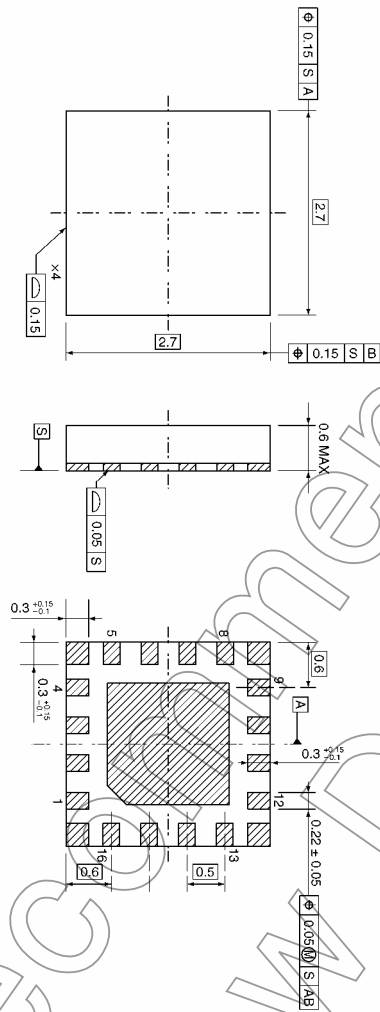

Note: The burr size as viewed from the top should not exceed 0.15 mm (max) per side.

Weight: 0.01 g (typ.)

Not Recommended for New Design

## Notes on Contents

### 1. Block Diagrams

Some of the functional blocks, circuits, or constants in the block diagram may be omitted or simplified for explanatory purposes.

### 2. Equivalent Circuits

The equivalent circuit diagrams may be simplified or some parts of them may be omitted for explanatory purposes.

### 3. Timing Charts

Timing charts may be simplified for explanatory purposes.

### 4. Application Circuits

The application circuits shown in this document are provided for reference purposes only. Thorough evaluation is required, especially at the mass production design stage.

Toshiba does not grant any license to any industrial property rights by providing these examples of application circuits.

### 5. Test Circuits

Components in the test circuits are used only to obtain and confirm the device characteristics. These components and circuits are not guaranteed to prevent malfunction or failure from occurring in the application equipment.

## IC Usage Considerations

### Notes on Handling of ICs

- (1) The absolute maximum ratings of a semiconductor device are a set of ratings that must not be exceeded, even for a moment. Do not exceed any of these ratings.  
Exceeding the rating(s) may cause the device breakdown, damage or deterioration, and may result injury by explosion or combustion.
- (2) Use an appropriate power supply fuse to ensure that a large current does not continuously flow in case of over current and/or IC failure. The IC will fully break down when used under conditions that exceed its absolute maximum ratings, when the wiring is routed improperly or when an abnormal pulse noise occurs from the wiring or load, causing a large current to continuously flow and the breakdown can lead smoke or ignition. To minimize the effects of the flow of a large current in case of breakdown, appropriate settings, such as fuse capacity, fusing time and insertion circuit location, are required.
- (3) If your design includes an inductive load such as a motor coil, incorporate a protection circuit into the design to prevent device malfunction or breakdown caused by the current resulting from the inrush current at power ON or the negative current resulting from the back electromotive force at power OFF. IC breakdown may cause injury, smoke or ignition.  
Use a stable power supply with ICs with built-in protection functions. If the power supply is unstable, the protection function may not operate, causing IC breakdown. IC breakdown may cause injury, smoke or ignition.
- (4) Do not insert devices in the wrong orientation or incorrectly.  
Make sure that the positive and negative terminals of power supplies are connected properly. Otherwise, the current or power consumption may exceed the absolute maximum rating, and exceeding the rating(s) may cause the device breakdown, damage or deterioration, and may result injury by explosion or combustion.  
In addition, do not use any device that is applied the current with inserting in the wrong orientation or incorrectly even just one time.

### Points to Remember on Handling of ICs

- (1) **Thermal Shutdown Circuit**  
Thermal shutdown circuits do not necessarily protect ICs under all circumstances. If the thermal shutdown circuits operate against the over temperature, clear the heat generation status immediately. Depending on the method of use and usage conditions, such as exceeding absolute maximum ratings can cause the thermal shutdown circuit to not operate properly or IC breakdown before operation.
- (2) **Heat Radiation Design**  
In using an IC with large current flow such as power amp, regulator or driver, please design the device so that heat is appropriately radiated, not to exceed the specified junction temperature ( $T_j$ ) at any time and condition. These ICs generate heat even during normal use. An inadequate IC heat radiation design can lead to decrease in IC life, deterioration of IC characteristics or IC breakdown. In addition, please design the device taking into consideration the effect of IC heat radiation with peripheral components.
- (3) **Back-EMF**  
When a motor rotates in the reverse direction, stops or slows down abruptly, a current flow back to the motor's power supply due to the effect of back-EMF. If the current sink capability of the power supply is small, the device's motor power supply and output pins might be exposed to conditions beyond maximum ratings. To avoid this problem, take the effect of back-EMF into consideration in system design.

Not Recommended for New Design

About solderability, following conditions were confirmed

- Solderability
  - (1) Use of Sn-37Pb solder Bath
    - solder bath temperature = 230°C
    - dipping time = 5 seconds
    - the number of times = once
    - use of R-type flux
  - (2) Use of Sn-3.0Ag-0.5Cu solder Bath
    - solder bath temperature = 245°C
    - dipping time = 5 seconds
    - the number of times = once
    - use of R-type flux

## RESTRICTIONS ON PRODUCT USE

070122EBA\_R6

- The information contained herein is subject to change without notice. 021023\_D
- TOSHIBA is continually working to improve the quality and reliability of its products. Nevertheless, semiconductor devices in general can malfunction or fail due to their inherent electrical sensitivity and vulnerability to physical stress. It is the responsibility of the buyer, when utilizing TOSHIBA products, to comply with the standards of safety in making a safe design for the entire system, and to avoid situations in which a malfunction or failure of such TOSHIBA products could cause loss of human life, bodily injury or damage to property.  
In developing your designs, please ensure that TOSHIBA products are used within specified operating ranges as set forth in the most recent TOSHIBA products specifications. Also, please keep in mind the precautions and conditions set forth in the "Handling Guide for Semiconductor Devices," or "TOSHIBA Semiconductor Reliability Handbook" etc. 021023\_A
- The TOSHIBA products listed in this document are intended for usage in general electronics applications (computer, personal equipment, office equipment, measuring equipment, industrial robotics, domestic appliances, etc.). These TOSHIBA products are neither intended nor warranted for usage in equipment that requires extraordinarily high quality and/or reliability or a malfunction or failure of which may cause loss of human life or bodily injury ("Unintended Usage"). Unintended Usage include atomic energy control instruments, airplane or spaceship instruments, transportation instruments, traffic signal instruments, combustion control instruments, medical instruments, all types of safety devices, etc. Unintended Usage of TOSHIBA products listed in this document shall be made at the customer's own risk. 021023\_B
- The products described in this document shall not be used or embedded to any downstream products of which manufacture, use and/or sale are prohibited under any applicable laws and regulations. 060106\_Q
- The information contained herein is presented only as a guide for the applications of our products. No responsibility is assumed by TOSHIBA for any infringements of patents or other rights of the third parties which may result from its use. No license is granted by implication or otherwise under any patents or other rights of TOSHIBA or the third parties. 070122\_C
- Please use this product in compliance with all applicable laws and regulations that regulate the inclusion or use of controlled substances.  
Toshiba assumes no liability for damage or losses occurring as a result of noncompliance with applicable laws and regulations. 060819\_AF
- The products described in this document are subject to foreign exchange and foreign trade control laws. 060925\_E

## Looking for pricing, stock, or lifecycle information?

Click below to explore more details on WIN SOURCE:

- ⊖ [View TB6590FTG\(UM,O,EL\) on WIN SOURCE](#)
- ⊖ [Toshiba Semiconductor and Storage Information](#)

## Optimize Your Supply Chain with WIN SOURCE Solutions

- ✓ Global Sourcing Solution
- ✓ Obsolete Management
- ✓ Cost Control Management
- ✓ Shortage Management
- ✓ Alternative Solution
- ✓ Excess Inventory Management