

74VHC123AFT, 74VHC221AFT

1. Functional Description

- Dual Monostable Multivibrator
- 74VHC123AFT: Retriggerable
- 74VHC221AFT: Non-Retriggerable

2. General

The 74VHC123A/221AFT are high speed CMOS MONOSTABLE MULTIVIBRATOR fabricated with silicon gate C²MOS technology.

There are two trigger inputs, \overline{A} input (negative edge), and B input (positive edge). These inputs are valid for a slow rise/fall time signal ($t_r = t_f = 1$ s) as they are schmitt trigger inputs. This device may also be triggered by using \overline{CLR} input (positive edge).

After triggering, the output stays in a MONOSTABLE state for a time period determined by the external resistor and capacitor (R_X , C_X). A low level at the \overline{CLR} input breaks this state.

Limits for C_X and R_X are:

External capacitor, C_X : No limit

External resistor, R_X : $V_{CC} = 2.0$ V more than 5 k Ω

$V_{CC} \geq 3.0$ V more than 1 k Ω

An input protection circuit ensures that 0 to 5.5 V can be applied to the input pins without regard to the supply voltage. This device can be used to interface 5 V to 3 V systems and two supply systems such as battery back up. This circuit prevents device destruction due to mismatched supply and input voltages.

3. Features (Note)

- (1) AEC-Q100 (Rev. H) (Note 1)
- (2) Wide operating temperature range: $T_{opr} = -40$ to 125 °C
- (3) High speed: Propagation delay time = 8.1 ns (typ.) at $V_{CC} = 5$ V
- (4) Low power dissipation:
 - Standby state: 4.0 μ A (max) at $T_a = 25$ °C
 - Active state: 750 μ A (max) at $T_a = 25$ °C
- (5) High noise immunity: $V_{NIH} = V_{NIL} = 28\%$ V_{CC} (min)
- (6) Power-down protection is provided on all inputs.
- (7) Balanced propagation delays: $t_{PLH} \approx t_{PHL}$
- (8) Wide operating voltage range: $V_{CC(opr)} = 2.0$ V to 5.5 V
- (9) Pin and function compatible with 74HC123, 74HC221 type.

Note: In the case of using only one circuit, \overline{CLR} should be tied to GND, $R_X/C_X \cdot C_X \cdot Q \cdot \overline{Q}$ should be tied to OPEN, the other inputs should be tied to V_{CC} or GND.

Note 1: This device is compliant with the reliability requirements of AEC-Q100. For details, contact your Toshiba sales representative.

4. Packaging

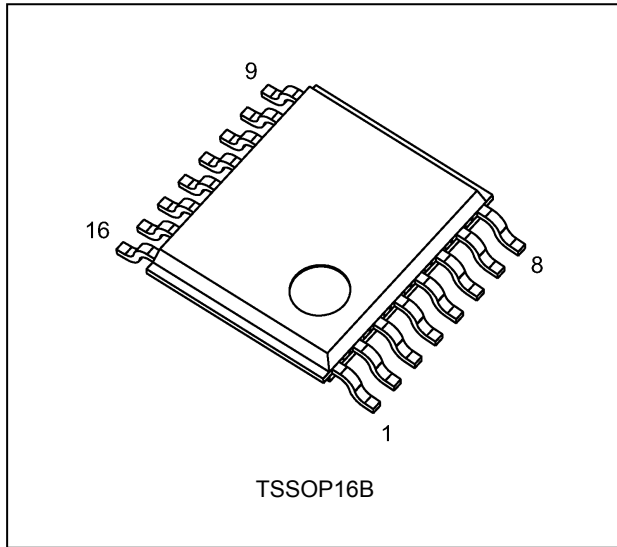

5. Pin Assignment

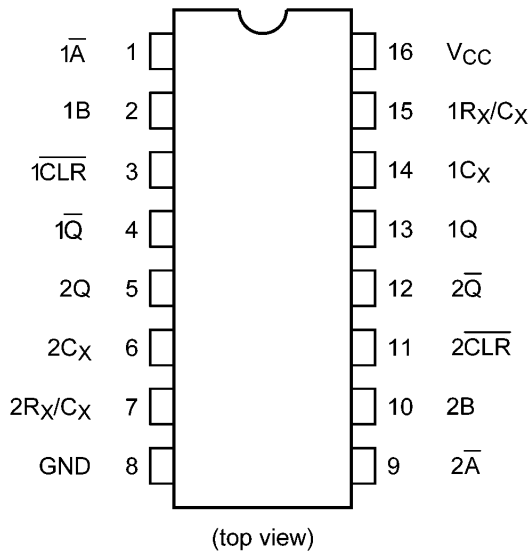

6. Marking

74VHC123AFT

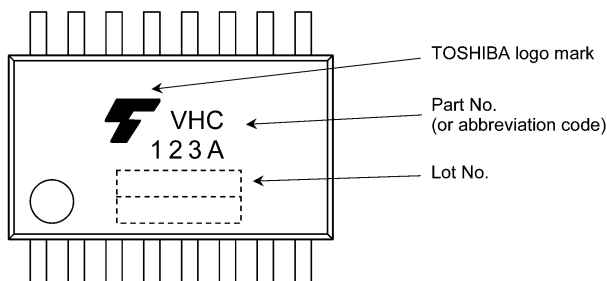

74VHC221AFT

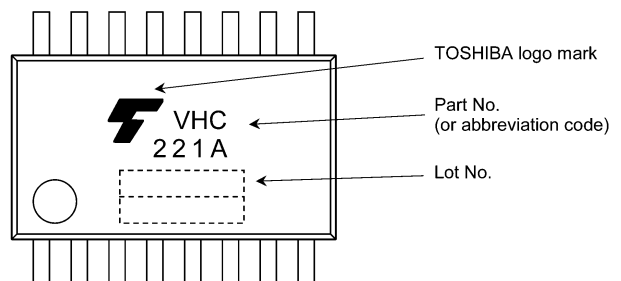

7. IEC Logic Symbol

74VHC123AFT

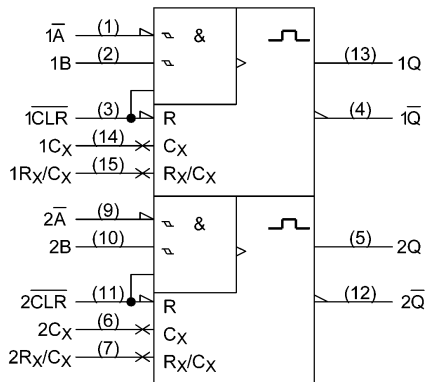

74VHC221AFT

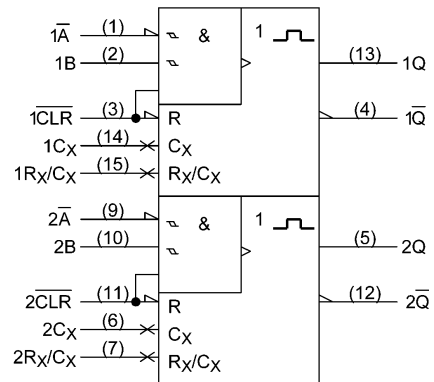

8. Truth Table

Inputs			Outputs		Function
\bar{A}	B	\bar{CLR}	Q	\bar{Q}	
	H	H			Output Enable
X	L	H	L	H	Inhibit
H	X	H	L	H	Inhibit
L		H			Output Enable
L	H				Output Enable
X	X	L	L	H	Reset

X: Don't care

9. Block Diagram

- (1) C_X , R_X , D_X are external
Capacitor, resistor, and diode, respectively.
- (2) External clamping diode, D_X ;

The external capacitor is charged to V_{CC} level in the wait state, i.e. when no trigger is applied. If the supply voltage is turned off, C_X is discharged mainly through the internal (parasitic) diode. If C_X is sufficiently large and V_{CC} drops rapidly, there will be some possibility of damaging the IC through inrush current or latch-up. If the capacitance of the supply voltage filter is large enough and V_{CC} drops slowly, the inrush current is automatically limited and damage to the IC is avoided.

The maximum value of forward current through the parasitic diode is ± 20 mA.

In the case of a large C_X , the limit of fall time of the supply voltage is determined as follows:

$$t_f \geq (V_{CC} - 0.7) C_X / 20 \text{ mA}$$

(t_f is the time between the supply voltage turn off and the supply voltage reaching $0.4 V_{CC}$.)

In the even a system does not satisfy the above condition, an external clamping diode (D_X) is needed to protect the IC from rush current.

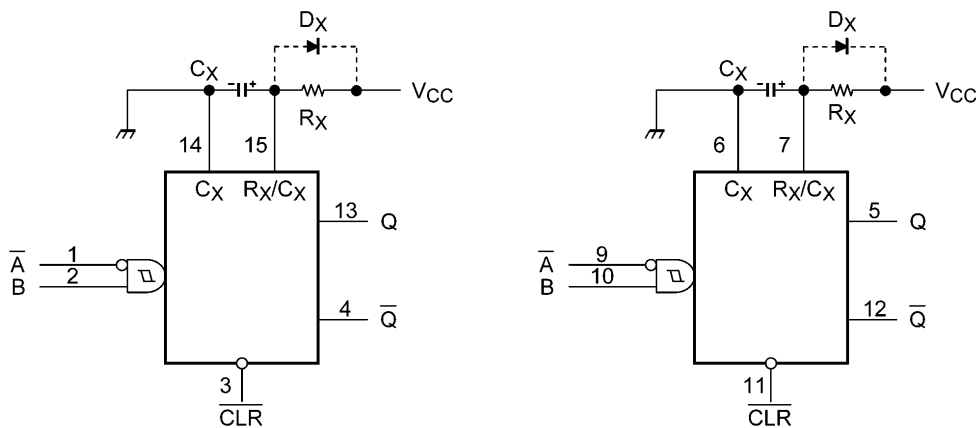

10. System Diagram

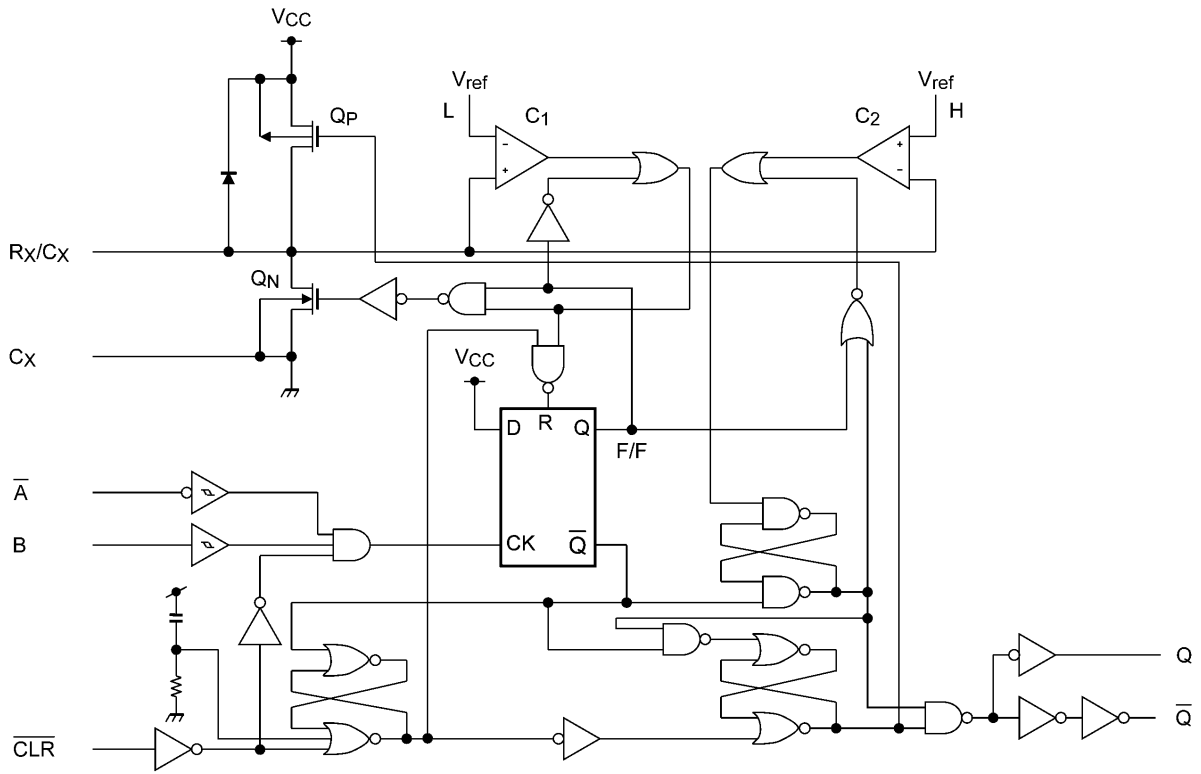

Fig. 10.1 74VHC123AFT

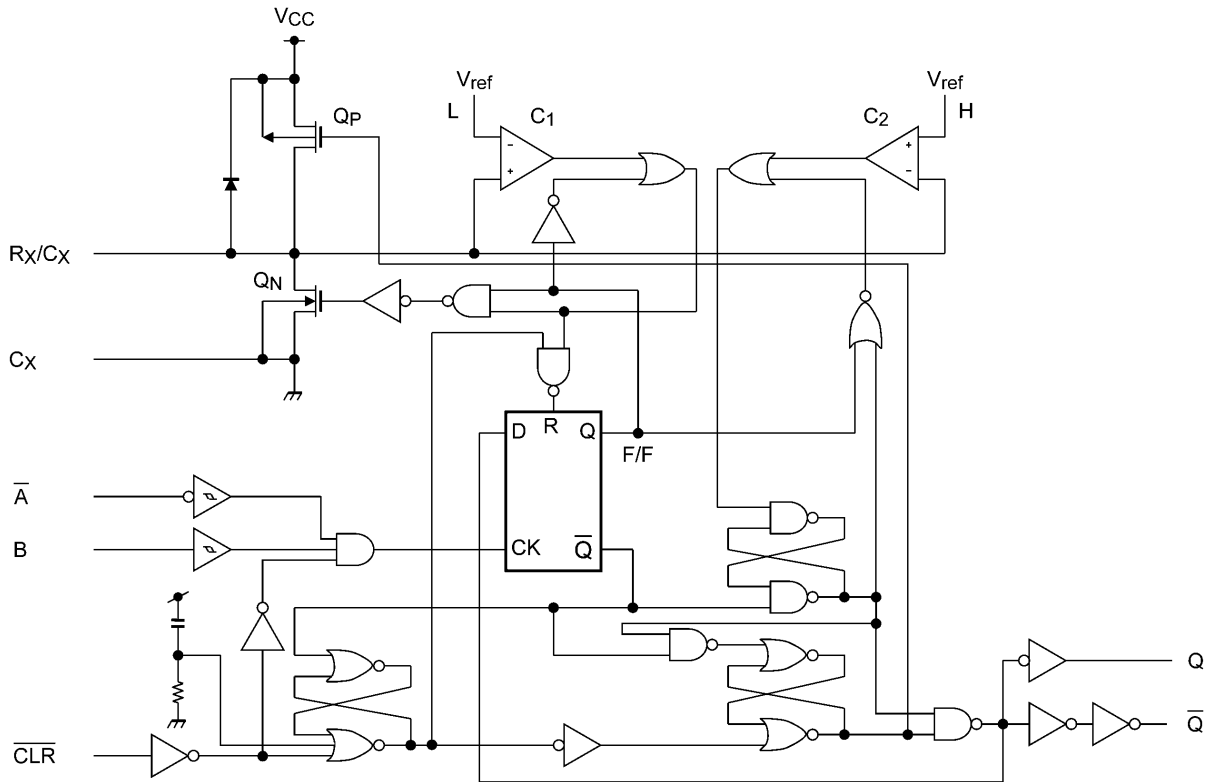

Fig. 10.2 74VHC221AFT

11. Timing Chart

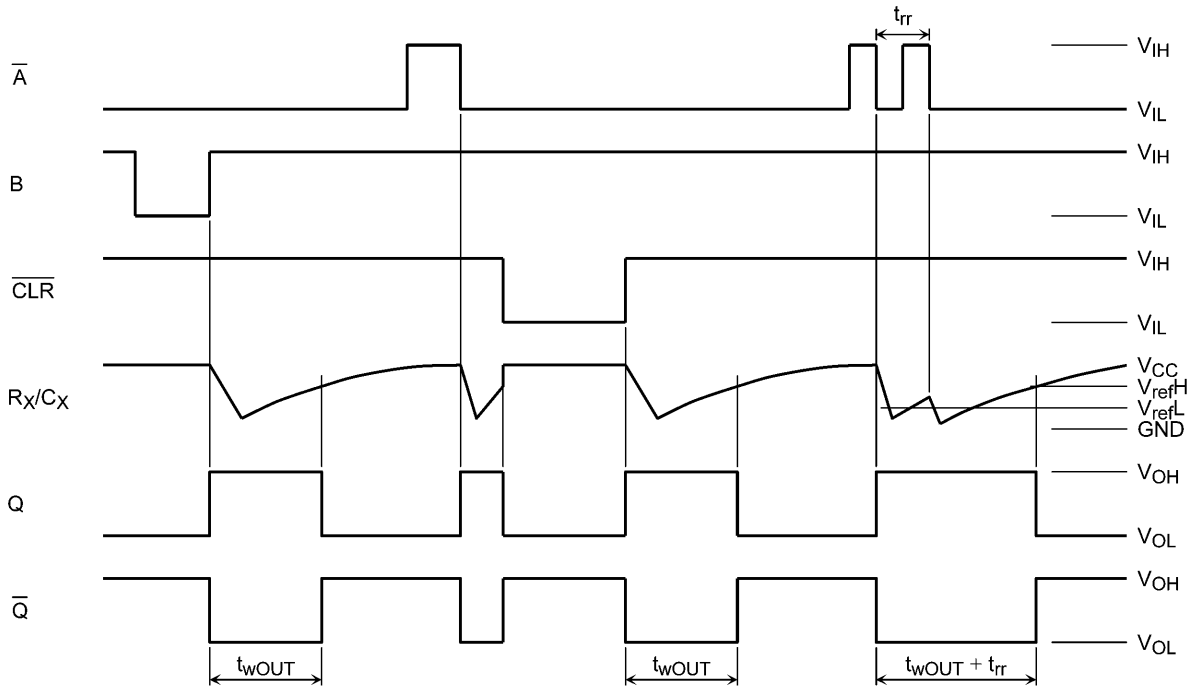

Fig. 11.1 74VHC123AFT

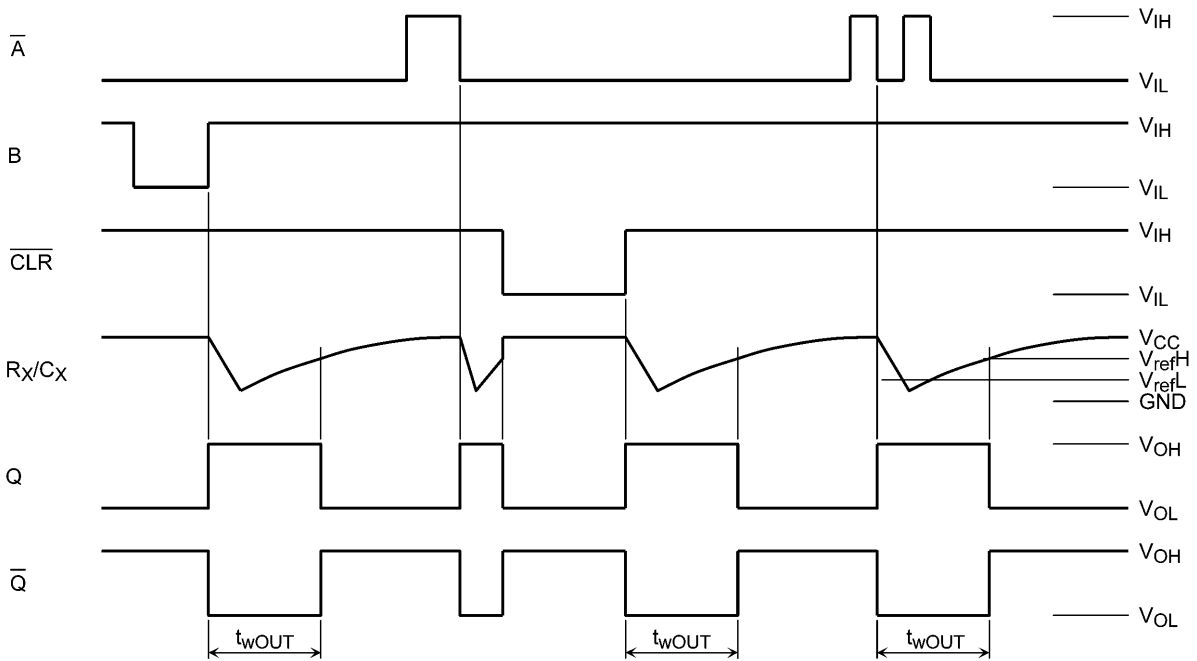

Fig. 11.2 74VHC221AFT

12. Functional Description

(1) Standby state

The external capacitor (C_X) is fully charged to V_{CC} in the stand-by state. That means, before triggering, the Q_P and Q_N transistors which are connected to the R_X/C_X node are in the off state. Two comparators that relate to the timing of the output pulse, and two reference voltage supplies turn off. The total supply current is only leakage current.

(2) Trigger operation

Trigger operation is effective in any of the following three cases. First, the condition where the \bar{A} input is low, and the B input has a rising signal; second, where the B input is high, and the \bar{A} input has a falling signal; and third, where the \bar{A} input is low and the B input is high, and the \overline{CLR} input has a rising signal. After a trigger becomes effective, comparators C_1 and C_2 start operating, and Q_N is turned on. The external capacitor discharges through Q_N . The voltage level at the R_X/C_X node drops. If the R_X/C_X voltage level falls to the internal reference voltage V_{refL} , the output of C_1 becomes low. The flip-flop is then reset and Q_N turns off. At that moment C_1 stops but C_2 continues operating.

After Q_N turns off, the voltage at the R_X/C_X node starts rising at a rate determined by the time constant of external capacitor C_X and resistor R_X .

Upon triggering, output Q becomes high, following some delay time of the internal F/F and gates. It stays high even if the voltage of R_X/C_X changes from falling to rising. When R_X/C_X reaches the internal reference voltage V_{refH} , the output of C_2 becomes low, the output Q goes low and C_2 stops its operation. That means, after triggering, when the voltage level of the R_X/C_X node reaches V_{refH} , the IC returns to its MONOSTABLE state.

With large values of C_X and R_X , and ignoring the discharge time of the capacitor and internal delays of the IC, the width of the output pulse, t_{wOUT} , is as follows:

$$t_{wOUT} = 1.0 \times C_X \times R_X$$

(3) Retrigger operation

When a new trigger is applied to either input \bar{A} or B while in the MONOSTABLE state, it is effective only if the IC is charging C_X . The voltage level of the R_X/C_X node then falls to V_{refL} level again. Therefore the Q output stays high if the next trigger comes in before the time period set by C_X and R_X .

If the new trigger is very close to previous trigger, such as an occurrence during the discharge cycle, it will have no effect.

The minimum time for a trigger to be effective 2 nd trigger, t_{tr} (min), depends on V_{CC} and C_X .(74VHC123AFT)

(4) Reset operation

In normal operation, the \overline{CLR} input is held high. If \overline{CLR} is low, a trigger has no effect because the Q output is held low and the trigger control F/F is reset. Also, Q_P turns on and C_X is charged rapidly to V_{CC} . This means if \overline{CLR} is set low, the IC goes into a wait state.

13. Absolute Maximum Ratings (Note)

Characteristics	Symbol	Note	Rating	Unit
Supply voltage	V_{CC}		-0.5 to 7.0	V
Input voltage	V_{IN}		-0.5 to 7.0	V
Output voltage	V_{OUT}		-0.5 to $V_{CC} + 0.5$	V
Input diode current	I_{IK}		-20	mA
Output diode current	I_{OK}		± 20	mA
Output current	I_{OUT}		± 25	mA
V_{CC} /ground current	I_{CC}		± 50	mA
Power dissipation	P_D	(Note 1)	180	mW
Storage temperature	T_{stg}		-65 to 150	$^{\circ}C$

Note: Exceeding any of the absolute maximum ratings, even briefly, lead to deterioration in IC performance or even destruction.

Using continuously under heavy loads (e.g. the application of high temperature/current/voltage and the significant change in temperature, etc.) may cause this product to decrease in the reliability significantly even if the operating conditions (i.e. operating temperature/current/voltage, etc.) are within the absolute maximum ratings and the operating ranges.

Please design the appropriate reliability upon reviewing the Toshiba Semiconductor Reliability Handbook (“Handling Precautions”/“Derating Concept and Methods”) and individual reliability data (i.e. reliability test report and estimated failure rate, etc).

Note 1: 180 mW in the range of $T_a = -40$ to $85^{\circ}C$. From $T_a = 85$ to $125^{\circ}C$ a derating factor of -3.25 mW/ $^{\circ}C$ shall be applied until 50 mW.

14. Operating Ranges (Note)

Characteristics	Symbol	Note	Test Condition	Rating	Unit
Supply voltage	V_{CC}		—	2.0 to 5.5	V
Input voltage	V_{IN}		—	0 to 5.5	V
Output voltage	V_{OUT}		—	0 to V_{CC}	V
Operating temperature	T_{opr}		—	-40 to 125	$^{\circ}C$
Input rise and fall times	dt/dv		$V_{CC} = 3.3 \pm 0.3$ V	0 to 100	ns/V
			$V_{CC} = 5 \pm 0.5$ V	0 to 20	
External capacitor	C_X	(Note 1)	—	No limitation	F
External resistor	R_X	(Note 1)	$V_{CC} = 2.0$ V	≥ 5 k	Ω
			$V_{CC} \geq 3.0$ V	≥ 1 k	

Note: The operating ranges must be maintained to ensure the normal operation of the device.

Unused inputs must be tied to either V_{CC} or GND.

Note 1: The maximum allowable values of C_X and R_X are a function of leakage of capacitor C_X , the leakage of 74VHC123A/221AFT, and leakage due to board layout and surface resistance.

Susceptibility to externally induced noise signals may occur for $R_X > 1$ M Ω .

15. Electrical Characteristics

15.1. DC Characteristics (Unless otherwise specified, $T_a = 25\text{ }^\circ\text{C}$)

Characteristics	Symbol	Test Condition	V_{CC} (V)	Min	Typ.	Max	Unit	
High-level input voltage	V_{IH}	—	2.0	1.50	—	—	V	
			3.0 to 5.5	$V_{CC} \times 0.7$	—	—		
Low-level input voltage	V_{IL}	—	2.0	—	—	0.50	V	
			3.0 to 5.5	—	—	$V_{CC} \times 0.3$		
High-level output voltage	V_{OH}	$V_{IN} = V_{IH}$ or V_{IL}	$I_{OH} = -50\text{ }\mu\text{A}$	2.0	1.9	2.0	—	V
				3.0	2.9	3.0	—	
				4.5	4.4	4.5	—	
			$I_{OH} = -4\text{ mA}$	3.0	2.58	—	—	
$I_{OH} = -8\text{ mA}$	4.5	3.94		—	—			
	Low-level output voltage	V_{OL}	$V_{IN} = V_{IH}$ or V_{IL}	$I_{OL} = 50\text{ }\mu\text{A}$	2.0	—	0.0	0.1
3.0					—	0.0	0.1	
4.5					—	0.0	0.1	
$I_{OL} = 4\text{ mA}$				3.0	—	—	0.36	
				$I_{OL} = 8\text{ mA}$	4.5	—	—	0.36
Input leakage current	I_{IN}	$V_{IN} = 5.5\text{ V}$ or GND	0 to 5.5		—	—	± 0.1	μA
R_X/C_X terminal OFF-state current	I_{IN}	$V_{IN} = V_{CC}$ or GND	5.5	—	—	± 0.25	μA	
Quiescent supply current	I_{CC}	$V_{IN} = V_{CC}$ or GND	5.5	—	—	4.0	μA	
Active-state supply current (per circuit)	$I_{CC(opr)}$	$V_{IN} = V_{CC}$ or GND $R_X/C_X = 0.5 V_{CC}$	3.0	—	160	250	μA	
			4.5	—	380	500		
			5.5	—	560	750		

15.2. DC Characteristics (Unless otherwise specified, $T_a = -40$ to $85\text{ }^\circ\text{C}$)

Characteristics	Symbol	Test Condition	V_{CC} (V)	Min	Max	Unit	
High-level input voltage	V_{IH}	—	2.0	1.50	—	V	
			3.0 to 5.5	$V_{CC} \times 0.7$	—		
Low-level input voltage	V_{IL}	—	2.0	—	0.50	V	
			3.0 to 5.5	—	$V_{CC} \times 0.3$		
High-level output voltage	V_{OH}	$V_{IN} = V_{IH}$ or V_{IL}	$I_{OH} = -50\text{ }\mu\text{A}$	2.0	1.9	—	V
				3.0	2.9	—	
				4.5	4.4	—	
			$I_{OH} = -4\text{ mA}$	3.0	2.48	—	
$I_{OH} = -8\text{ mA}$	4.5	3.80		—			
	Low-level output voltage	V_{OL}	$V_{IN} = V_{IH}$ or V_{IL}	$I_{OL} = 50\text{ }\mu\text{A}$	2.0	—	0.1
3.0					—	0.1	
4.5					—	0.1	
$I_{OL} = 4\text{ mA}$				3.0	—	0.44	
				$I_{OL} = 8\text{ mA}$	4.5	—	0.44
Input leakage current	I_{IN}	$V_{IN} = 5.5\text{ V}$ or GND	0 to 5.5		—	± 1.0	μA
R_X/C_X terminal OFF-state current	I_{IN}	$V_{IN} = V_{CC}$ or GND	5.5	—	± 2.5	μA	
Quiescent supply current	I_{CC}	$V_{IN} = V_{CC}$ or GND	5.5	—	40.0	μA	
Active-state supply current (per circuit)	$I_{CC(opr)}$	$V_{IN} = V_{CC}$ or GND $R_X/C_X = 0.5 V_{CC}$	3.0	—	280	μA	
			4.5	—	650		
			5.5	—	975		

15.3. DC Characteristics (Unless otherwise specified, $T_a = -40$ to 125 °C)

Characteristics	Symbol	Test Condition		V_{CC} (V)	Min	Max	Unit
High-level input voltage	V_{IH}	—		2.0	1.50	—	V
				3.0 to 5.5	$V_{CC} \times 0.7$	—	
Low-level input voltage	V_{IL}	—		2.0	—	0.50	V
				3.0 to 5.5	—	$V_{CC} \times 0.3$	
High-level output voltage	V_{OH}	$V_{IN} = V_{IH}$ or V_{IL}	$I_{OH} = -50 \mu A$	2.0	1.9	—	V
				3.0	2.9	—	
				4.5	4.4	—	
				$I_{OH} = -4$ mA	3.0	2.40	
Low-level output voltage	V_{OL}	$V_{IN} = V_{IH}$ or V_{IL}	$I_{OL} = 50 \mu A$	2.0	—	0.1	V
				3.0	—	0.1	
				4.5	—	0.1	
				$I_{OL} = 4$ mA	3.0	—	
Input leakage current	I_{IN}	$V_{IN} = 5.5$ V or GND		0 to 5.5	—	± 2.0	μA
				5.5	—	± 10.0	
R_X/C_X terminal OFF-state current	I_{IN}	$V_{IN} = V_{CC}$ or GND		5.5	—	± 10.0	μA
Quiescent supply current	I_{CC}	$V_{IN} = V_{CC}$ or GND		5.5	—	80.0	μA
Active-state supply current (per circuit)	$I_{CC(opr)}$	$V_{IN} = V_{CC}$ or GND $R_X/C_X = 0.5 V_{CC}$		3.0	—	280	μA
				4.5	—	650	
				5.5	—	975	

15.4. Timing Requirements (Unless otherwise specified, $T_a = 25$ °C, Input: $t_r = t_f = 3$ ns)

Characteristics	Part Number	Symbol	Test Condition	V_{CC} (V)	Typ.	Limit	Unit
Minimum pulse width		$t_{w(L)}, t_{w(H)}$	—	3.3 ± 0.3	—	5.0	ns
				5.0 ± 0.5	—	5.0	
Minimum pulse width (CLR)		$t_{w(L)}$	—	3.3 ± 0.3	—	5.0	ns
				5.0 ± 0.5	—	5.0	
Minimum retrigger time	74VHC123AFT	t_{rr}	$R_X = 1$ k Ω , $C_X = 100$ pF	3.3 ± 0.3	60	—	ns
				5.0 ± 0.5	39	—	
			$R_X = 1$ k Ω , $C_X = 0.01$ μF	3.3 ± 0.3	1.5	—	μs
				5.0 ± 0.5	1.2	—	

15.5. Timing Requirements (Unless otherwise specified, $T_a = -40$ to 85 °C, Input: $t_r = t_f = 3$ ns)

Characteristics	Symbol	Test Condition	V_{CC} (V)	Limit	Unit
Minimum pulse width	$t_{w(L)}, t_{w(H)}$	—	3.3 ± 0.3	5.0	ns
			5.0 ± 0.5	5.0	
Minimum pulse width (CLR)	$t_{w(L)}$	—	3.3 ± 0.3	5.0	ns
			5.0 ± 0.5	5.0	

15.6. Timing Requirements
(Unless otherwise specified, $T_a = -40$ to 125 °C, Input: $t_r = t_f = 3$ ns)

Characteristics	Symbol	Test Condition	V_{CC} (V)	Limit	Unit
Minimum pulse width	$t_{w(L)}, t_{w(H)}$	—	3.3 ± 0.3	5.0	ns
			5.0 ± 0.5	5.0	
Minimum pulse width (\overline{CLR})	$t_{w(L)}$	—	3.3 ± 0.3	5.0	ns
			5.0 ± 0.5	5.0	

15.7. AC Characteristics (Unless otherwise specified, $T_a = 25$ °C, Input: $t_r = t_f = 3$ ns)

Characteristics	Symbol	Note	Test Condition	V_{CC} (V)	C_L (pF)	Min	Typ.	Max	Unit
Propagation delay time (A, B-Q, \overline{Q})	t_{PLH}, t_{PHL}		—	3.3 ± 0.3	15	—	13.4	20.6	ns
					50	—	15.9	24.1	
				5.0 ± 0.5	15	—	8.1	12.0	
					50	—	9.6	14.0	
Propagation delay time (CLR trigger-Q, \overline{Q})	t_{PLH}, t_{PHL}		—	3.3 ± 0.3	15	—	14.5	22.4	ns
					50	—	17.0	25.9	
				5.0 ± 0.5	15	—	8.7	12.9	
					50	—	10.2	14.9	
Propagation delay time (\overline{CLR} -Q, \overline{Q})	t_{PLH}, t_{PHL}		—	3.3 ± 0.3	15	—	10.3	15.8	ns
					50	—	12.8	19.3	
				5.0 ± 0.5	15	—	6.3	9.4	
					50	—	7.8	11.4	
Output pulse width	t_{wOUT}		$C_X = 28$ pF, $R_X = 2$ k Ω	3.3 ± 0.3	50	—	160	240	ns
						5.0 ± 0.5	—	133	
				3.3 ± 0.3	50	90	100	110	μ s
						5.0 ± 0.5	90	100	
				3.3 ± 0.3	50	0.9	1.0	1.1	ms
						5.0 ± 0.5	0.9	1.0	
Output pulse width error between circuits (in same package)	Δt_{wOUT}		—			—	± 1	—	%
Input capacitance	C_{IN}		—			—	4	10	pF
Power dissipation capacitance	C_{PD}	(Note 1)	—			—	73	—	pF

Note 1: C_{PD} is defined as the value of the internal equivalent capacitance which is calculated from the operating current consumption without load. Average operating current can be obtained by the equation.

$$I_{CC(opr)} = C_{PD} \times V_{CC} \times f_{IN} + I_{CC'} \times \text{Duty}/100 + I_{CC}/2 \text{ (per circuit),}$$

($I_{CC'}$: Active supply current),
(Duty: %)

15.8. AC Characteristics

(Unless otherwise specified, $T_a = -40$ to 85 °C, Input: $t_r = t_f = 3$ ns)

Characteristics	Symbol	Test Condition	V_{CC} (V)	C_L (pF)	Min	Max	Unit		
Propagation delay time (A, B-Q, \bar{Q})	t_{PLH}, t_{PHL}	—	3.3 ± 0.3	15	1.0	24.0	ns		
				50	1.0	27.5			
			5.0 ± 0.5	15	1.0	14.0			
				50	1.0	16.0			
Propagation delay time (CLR trigger-Q, \bar{Q})	t_{PLH}, t_{PHL}	—	3.3 ± 0.3	15	1.0	26.0	ns		
				50	1.0	29.5			
			5.0 ± 0.5	15	1.0	15.0			
				50	1.0	17.0			
Propagation delay time (CLR-Q, \bar{Q})	t_{PLH}, t_{PHL}	—	3.3 ± 0.3	15	1.0	18.5	ns		
				50	1.0	22.0			
			5.0 ± 0.5	15	1.0	11.0			
				50	1.0	13.0			
Output pulse width	t_{WOUT}	$C_X = 28$ pF, $R_X = 2$ k Ω	3.3 ± 0.3	50	—	300	ns		
					5.0 ± 0.5	—		240	
			$C_X = 0.01$ μ F, $R_X = 10$ k Ω	3.3 ± 0.3	50	90	110	μ s	
						5.0 ± 0.5	90		110
		$C_X = 0.1$ μ F, $R_X = 10$ k Ω	3.3 ± 0.3	50	0.9	1.1	ms		
					5.0 ± 0.5	0.9		1.1	
		Input capacitance	C_{IN}	—			—	10	pF

15.9. AC Characteristics

(Unless otherwise specified, $T_a = -40$ to 125 °C, Input: $t_r = t_f = 3$ ns)

Characteristics	Symbol	Test Condition	V_{CC} (V)	C_L (pF)	Min	Max	Unit		
Propagation delay time (A, B-Q, \bar{Q})	t_{PLH}, t_{PHL}	—	3.3 ± 0.3	15	1.0	27.0	ns		
				50	1.0	30.5			
			5.0 ± 0.5	15	1.0	15.5			
				50	1.0	17.5			
Propagation delay time (CLR trigger-Q, \bar{Q})	t_{PLH}, t_{PHL}	—	3.3 ± 0.3	15	1.0	29.0	ns		
				50	1.0	32.5			
			5.0 ± 0.5	15	1.0	17.0			
				50	1.0	19.0			
Propagation delay time (CLR-Q, \bar{Q})	t_{PLH}, t_{PHL}	—	3.3 ± 0.3	15	1.0	21.0	ns		
				50	1.0	24.5			
			5.0 ± 0.5	15	1.0	12.5			
				50	1.0	14.5			
Output pulse width	t_{WOUT}	$C_X = 28$ pF, $R_X = 2$ k Ω	3.3 ± 0.3	50	—	300	ns		
					5.0 ± 0.5	50		—	240
			$C_X = 0.01$ μ F, $R_X = 10$ k Ω	3.3 ± 0.3	50	85	115	μ s	
						5.0 ± 0.5	50		85
		$C_X = 0.1$ μ F, $R_X = 10$ k Ω	3.3 ± 0.3	50	0.85	1.15	ms		
					5.0 ± 0.5	50		0.85	1.15
		Input capacitance	C_{IN}	—			—	10	pF

16. Characteristics Curves (Note)

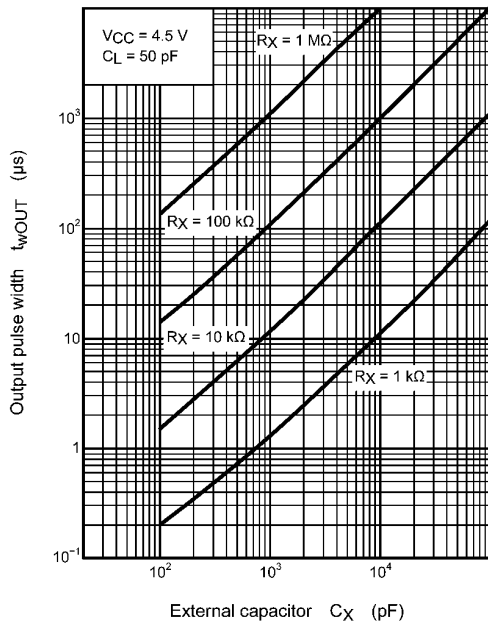
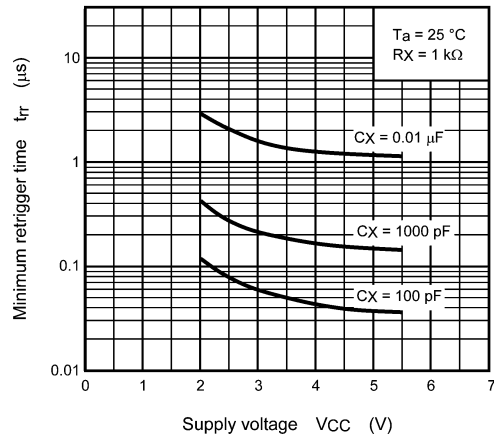

Fig. 16.1 t_{wOUT} - C_X (typ.)



**Fig. 16.2 t_r - V_{CC} (typ.)
(74VHC123AFT)**

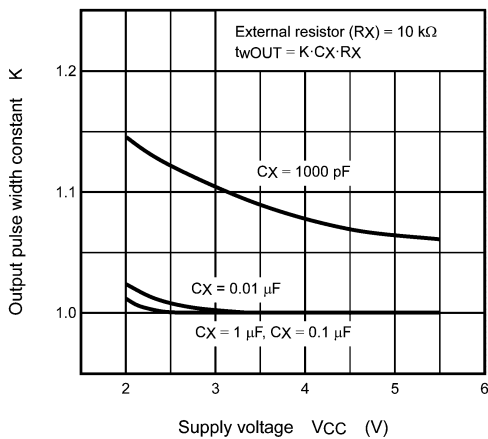
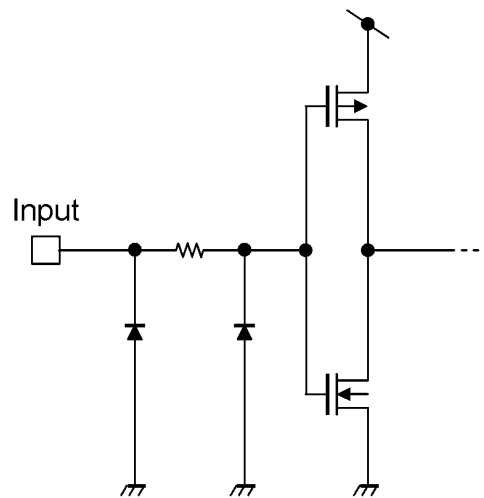

Fig. 16.3 Output Pulse Width Constant K - Supply Voltage (typ.)

Note: The above characteristics curves are presented for reference only and not guaranteed by production test, unless otherwise noted.

17. Internal Equivalent Circuit



Package Dimensions

Unit: mm

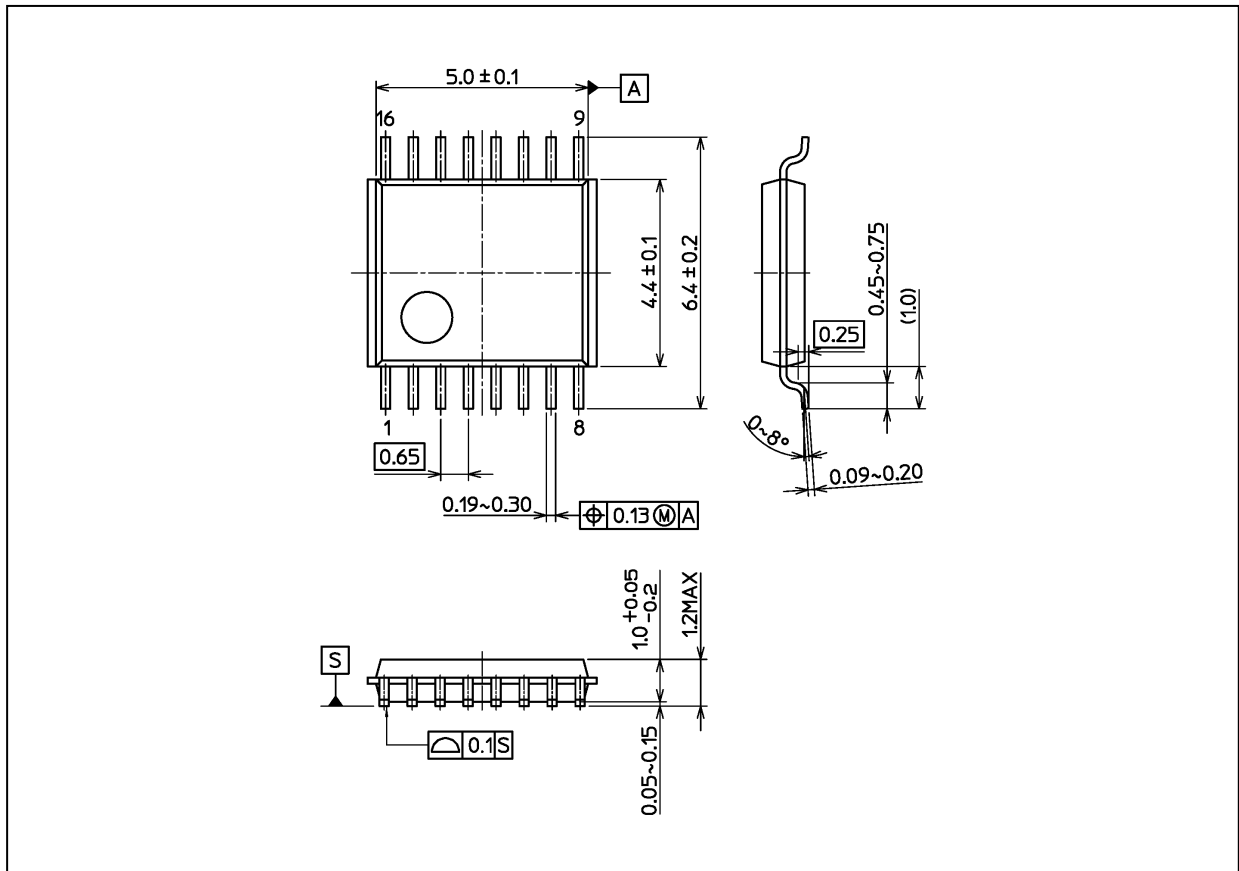

Weight: 0.055 g (typ.)

Package Name(s)
Nickname: TSSOP16B

RESTRICTIONS ON PRODUCT USE

- Toshiba Corporation, and its subsidiaries and affiliates (collectively "TOSHIBA"), reserve the right to make changes to the information in this document, and related hardware, software and systems (collectively "Product") without notice.
- This document and any information herein may not be reproduced without prior written permission from TOSHIBA. Even with TOSHIBA's written permission, reproduction is permissible only if reproduction is without alteration/omission.
- Though TOSHIBA works continually to improve Product's quality and reliability, Product can malfunction or fail. Customers are responsible for complying with safety standards and for providing adequate designs and safeguards for their hardware, software and systems which minimize risk and avoid situations in which a malfunction or failure of Product could cause loss of human life, bodily injury or damage to property, including data loss or corruption. Before customers use the Product, create designs including the Product, or incorporate the Product into their own applications, customers must also refer to and comply with (a) the latest versions of all relevant TOSHIBA information, including without limitation, this document, the specifications, the data sheets and application notes for Product and the precautions and conditions set forth in the "TOSHIBA Semiconductor Reliability Handbook" and (b) the instructions for the application with which the Product will be used with or for. Customers are solely responsible for all aspects of their own product design or applications, including but not limited to (a) determining the appropriateness of the use of this Product in such design or applications; (b) evaluating and determining the applicability of any information contained in this document, or in charts, diagrams, programs, algorithms, sample application circuits, or any other referenced documents; and (c) validating all operating parameters for such designs and applications. **TOSHIBA ASSUMES NO LIABILITY FOR CUSTOMERS' PRODUCT DESIGN OR APPLICATIONS.**
- **PRODUCT IS NEITHER INTENDED NOR WARRANTED FOR USE IN EQUIPMENTS OR SYSTEMS THAT REQUIRE EXTRAORDINARILY HIGH LEVELS OF QUALITY AND/OR RELIABILITY, AND/OR A MALFUNCTION OR FAILURE OF WHICH MAY CAUSE LOSS OF HUMAN LIFE, BODILY INJURY, SERIOUS PROPERTY DAMAGE AND/OR SERIOUS PUBLIC IMPACT ("UNINTENDED USE").** Except for specific applications as expressly stated in this document, Unintended Use includes, without limitation, equipment used in nuclear facilities, equipment used in the aerospace industry, medical equipment, equipment used for automobiles, trains, ships and other transportation, traffic signaling equipment, equipment used to control combustions or explosions, safety devices, elevators and escalators, devices related to electric power, and equipment used in finance-related fields. **IF YOU USE PRODUCT FOR UNINTENDED USE, TOSHIBA ASSUMES NO LIABILITY FOR PRODUCT.** For details, please contact your TOSHIBA sales representative.
- Do not disassemble, analyze, reverse-engineer, alter, modify, translate or copy Product, whether in whole or in part.
- Product shall not be used for or incorporated into any products or systems whose manufacture, use, or sale is prohibited under any applicable laws or regulations.
- The information contained herein is presented only as guidance for Product use. No responsibility is assumed by TOSHIBA for any infringement of patents or any other intellectual property rights of third parties that may result from the use of Product. No license to any intellectual property right is granted by this document, whether express or implied, by estoppel or otherwise.
- **ABSENT A WRITTEN SIGNED AGREEMENT, EXCEPT AS PROVIDED IN THE RELEVANT TERMS AND CONDITIONS OF SALE FOR PRODUCT, AND TO THE MAXIMUM EXTENT ALLOWABLE BY LAW, TOSHIBA (1) ASSUMES NO LIABILITY WHATSOEVER, INCLUDING WITHOUT LIMITATION, INDIRECT, CONSEQUENTIAL, SPECIAL, OR INCIDENTAL DAMAGES OR LOSS, INCLUDING WITHOUT LIMITATION, LOSS OF PROFITS, LOSS OF OPPORTUNITIES, BUSINESS INTERRUPTION AND LOSS OF DATA, AND (2) DISCLAIMS ANY AND ALL EXPRESS OR IMPLIED WARRANTIES AND CONDITIONS RELATED TO SALE, USE OF PRODUCT, OR INFORMATION, INCLUDING WARRANTIES OR CONDITIONS OF MERCHANTABILITY, FITNESS FOR A PARTICULAR PURPOSE, ACCURACY OF INFORMATION, OR NONINFRINGEMENT.**
- Do not use or otherwise make available Product or related software or technology for any military purposes, including without limitation, for the design, development, use, stockpiling or manufacturing of nuclear, chemical, or biological weapons or missile technology products (mass destruction weapons). Product and related software and technology may be controlled under the applicable export laws and regulations including, without limitation, the Japanese Foreign Exchange and Foreign Trade Law and the U.S. Export Administration Regulations. Export and re-export of Product or related software or technology are strictly prohibited except in compliance with all applicable export laws and regulations.
- Please contact your TOSHIBA sales representative for details as to environmental matters such as the RoHS compatibility of Product. Please use Product in compliance with all applicable laws and regulations that regulate the inclusion or use of controlled substances, including without limitation, the EU RoHS Directive. **TOSHIBA ASSUMES NO LIABILITY FOR DAMAGES OR LOSSES OCCURRING AS A RESULT OF NONCOMPLIANCE WITH APPLICABLE LAWS AND REGULATIONS.**

Looking for pricing, stock, or lifecycle information?

Click below to explore more details on WIN SOURCE:

- ⊖ [View 74VHC221AFT on WIN SOURCE](#)
- ⊖ [Toshiba Semiconductor and Storage Information](#)

Optimize Your Supply Chain with WIN SOURCE Solutions

- ✓ Global Sourcing Solution
- ✓ Obsolete Management
- ✓ Cost Control Management
- ✓ Shortage Management
- ✓ Alternative Solution
- ✓ Excess Inventory Management