



# THE DATASHEET OF TAS5611APHDR



# 125W STEREO/250W MONO PurePath™ HD ANALOG-INPUT POWER STAGE

Check for Samples: [TAS5611A](#)

## FEATURES

- **PurePath™ HD Enabled Integrated Feedback Provides:**
  - Signal Bandwidth up to 80kHz for High Frequency Content From HD Sources
  - Ultralow 0.03% THD at 1W into 4Ω
  - Flat THD at all Frequencies for Natural Sound
  - 80dB PSRR (BTL, No Input Signal)
  - >100dB (A weighted) SNR
  - Click and Pop Free Startup
- **Pin compatible with TAS5630, TAS5615 and TAS5613**
- **Multiple Configurations Possible on the Same PCB With Stuffing Options:**
  - Mono Parallel Bridge Tied Load (PBTL)
  - Stereo Bridge Tied Load (BTL)
  - 2.1 Single Ended Stereo Pair and Bridge Tied Load Subwoofer
- **Total Output Power at 10%THD+N**
  - 250W in Mono PBTL Configuration into 2Ω
  - 125W per Channel in Stereo BTL Configuration into 4Ω
- **Total Output Power in BTL configuration at 1%THD+N**
  - 130W Stereo into 3Ω
  - 105W Stereo into 4Ω
  - 70W Stereo into 6Ω
  - 55W Stereo into 8Ω
- **>90% Efficient Power Stage With 60-mΩ Output MOSFETs**
- **Self-Protection Design (Including Undervoltage, Overtemperature, Clipping, and Short-Circuit Protection) With Error Reporting**
- **EMI Compliant When Used With Recommended System Design**
- **Thermally Enhanced Package Options:**
  - PHD (64-Pin QFP)

## APPLICATIONS

- Home Theater Systems
- AV Receivers
- DVD/Blu-ray Receivers
- Mini Combo System
- Active Speakers and Subwoofers

## DESCRIPTION

The TAS5611A is a high performance analog input Class D amplifier with integrated closed loop feedback technology (known as PurePath™ HD) with the ability to drive up to 125W <sup>(1)</sup> Stereo into 4 to 8 Ω Speakers from a single 32.5V supply.

PurePath™ HD technology enables traditional AB-Amplifier performance (<0.03% THD) levels while providing the power efficiency of traditional class D amplifiers.

Unlike traditional Class D amplifiers, the distortion curve only increases once the output levels move into clipping.

PurePath™ HD technology enables lower idle losses making the device even more efficient.

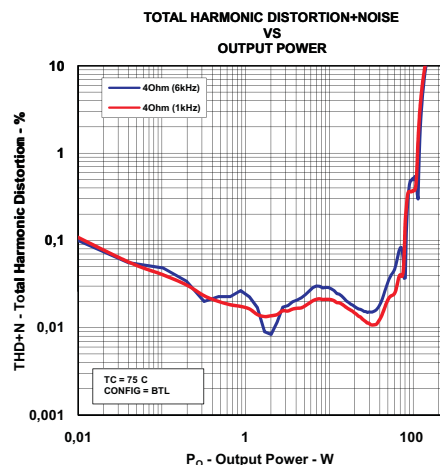

- (1) Achievable output power levels are dependent on the thermal configuration of the target application. A high performance thermal interface material between the package exposed heatslug and the heat sink should be used to achieve high output power levels.



Please be aware that an important notice concerning availability, standard warranty, and use in critical applications of Texas Instruments semiconductor products and disclaimers thereto appears at the end of this data sheet.

PurePath, Power PAD are trademarks of Texas Instruments.  
All other trademarks are the property of their respective owners.

UNLESS OTHERWISE NOTED this document contains PRODUCTION DATA information current as of publication date. Products conform to specifications per the terms of Texas Instruments standard warranty. Production processing does not necessarily include testing of all parameters.



These devices have limited built-in ESD protection. The leads should be shorted together or the device placed in conductive foam during storage or handling to prevent electrostatic damage to the MOS gates.

## DEVICE INFORMATION

### Pin Assignment

The TAS5611A is available in a thermally enhanced packages:

- 64-Pin QFP (PHD) Power Package

The package types contain heat slugs that are located on the top side of the device for convenient thermal coupling to the heat sink.

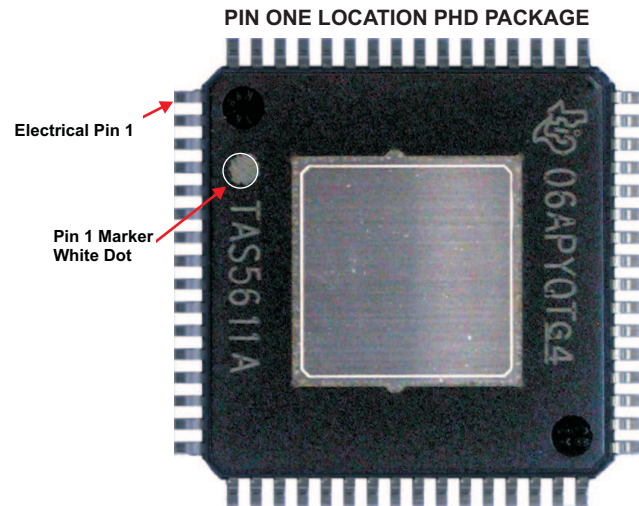
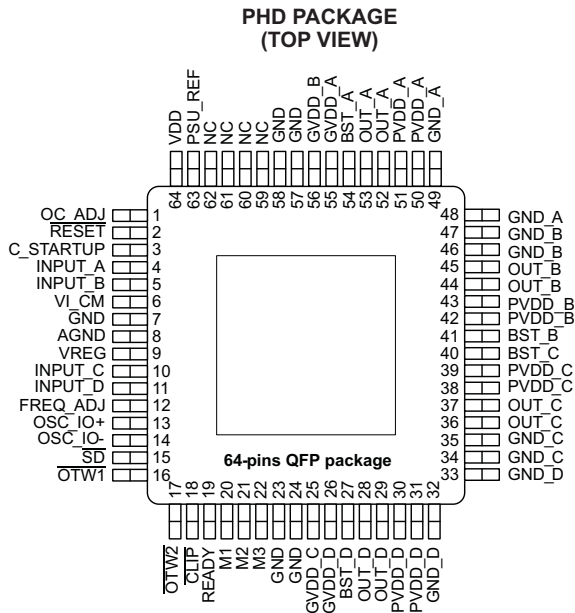

### MODE SELECTION PINS

| MODE PINS |    |    | ANALOG INPUT              | OUTPUT CONFIGURATION | DESCRIPTION               |                        |         |
|-----------|----|----|---------------------------|----------------------|---------------------------|------------------------|---------|
| M3        | M2 | M1 |                           |                      | INPUT_C <sup>(1)</sup>    | INPUT_D <sup>(1)</sup> |         |
| 0         | 0  | 0  | Differential              | 2 × BTL              | AD mode                   |                        |         |
| 0         | 0  | 1  | —                         | —                    | Reserved                  |                        |         |
| 0         | 1  | 0  | Differential              | 2 × BTL              | BD mode                   |                        |         |
| 0         | 1  | 1  | Differential Single Ended | 1 × BTL + 2 × SE     | BD mode, BTL Differential |                        |         |
| 1         | 0  | 0  | Single Ended              | 4 × SE               | AD mode                   |                        |         |
| 1         | 0  | 1  | Differential              | 1 × PBTL             | 0                         | 0                      | AD mode |
|           |    |    |                           |                      | 1                         | 0                      | BD mode |
| 1         | 1  | 0  | Reserved                  |                      |                           |                        |         |
| 1         | 1  | 1  | Reserved                  |                      |                           |                        |         |

(1) INPUT\_C and D are used to select between a subset of AD and BD mode operations in PBTL mode (1=VREG and 0=GND).

**PACKAGE HEAT DISSIPATION RATINGS<sup>(1)</sup>**

| PARAMETER   | TAS5611APHD        |
|---|--------------------|
| $R_{\theta JC}$ (°C/W) – 2 BTL or 4 SE channels   | 3.2                |
| $R_{\theta JC}$ (°C/W) – 1 BTL or 2 SE channel(s) | 5.4                |
| $R_{\theta JC}$ (°C/W) – 1 SE channel             | 7.9                |
| Pad Area <sup>(2)</sup>                           | 64 mm <sup>2</sup> |

- (1)  $J_C$  is junction-to-case, CH is case-to-heat sink  
 (2)  $R_{\theta CH}$  is an important consideration. Assume a 2-mil thickness of thermal grease with a thermal conductivity of 2.5 W/mK between the pad area and the heat sink and both channels active. The  $R_{\theta CH}$  with this condition is 1.1°C/W for the PHD package and 0.44°C/W for the DKD package.

**Table 1. ORDERING INFORMATION<sup>(1)</sup>**

| $T_A$    | PACKAGE     | DESCRIPTION  |
|----------|-------------|--------------|
| 0°C–70°C | TAS5611APHD | 64 pin HTQFP |

- (1) For the most current package and ordering information, see the Package Option Addendum at the end of this document, or see the TI website at [www.ti.com](http://www.ti.com).

**ABSOLUTE MAXIMUM RATINGS**

 over operating free-air temperature range unless otherwise noted <sup>(1)</sup>

|  | VALUE  | UNIT   |
|--|--|--------|
| VDD to GND   | –0.3 to 13.2                                   | V      |
| GVDD to GND  | –0.3 to 13.2                                   | V      |
| PVDD_X to GND_X <sup>(2)</sup>   | –0.3 to 53                                     | V      |
| OUT_X to GND_X <sup>(2)</sup>  | –0.3 to 53                                     | V      |
| BST_X to GND_X <sup>(2)</sup>  | –0.3 to 66.2                                   | V      |
| BST_X to GVDD_X <sup>(2)</sup>   | –0.3 to 53                                     | V      |
| VREG to GND  | –0.3 to 4.2                                    | V      |
| GND_X to GND   | –0.3 to 0.3                                    | V      |
| GND to AGND  | –0.3 to 0.3                                    | V      |
| OC_ADJ, M1, M2, M3, OSC_IO+, OSC_IO-, FREQ_ADJ, VI_CM, C_STARTUP, PSU_REF to GND   | –0.3 to 4.2                                    | V      |
| INPUT_X  | –0.3 to 7                                      | V      |
| $\overline{RESET}$ , $\overline{SD}$ , $\overline{OTW1}$ , $\overline{OTW2}$ , $\overline{CLIP}$ , $\overline{READY}$ to GND | –0.3 to 7                                      | V      |
| Continuous sink current ( $\overline{SD}$ , $\overline{OTW1}$ , $\overline{OTW2}$ , $\overline{CLIP}$ , $\overline{READY}$ ) | 9  | mA     |
| Operating junction temperature range, $T_J$  | 0 to 150                                       | °C     |
| Storage temperature, $T_{stg}$   | –40 to 150                                     | °C     |
| Electrostatic discharge  | Human body model <sup>(3)</sup> (all pins)     | ±2 kV  |
|  | Charged device model <sup>(3)</sup> (all pins) | ±500 V |

- (1) Stresses beyond those listed under *Absolute Maximum Ratings* may cause permanent damage to the device. These are stress ratings only, and functional operation of the device at these or any other conditions beyond those indicated under *Recommended Operating Conditions* is not implied. Exposure to absolute-maximum-rated conditions for extended periods may affect device reliability.  
 (2) These voltages represents the DC voltage + peak AC waveform measured at the terminal of the device in all conditions.  
 (3) Failure to follow good anti-static ESD handling during manufacture and rework will contribute to device malfunction. Please ensure operators handling the device are adequately grounded through the use of ground straps or alternative ESD protection.

## RECOMMENDED OPERATING CONDITIONS

over operating free-air temperature range (unless otherwise noted)

|                            |   | MIN                  | TYP  | MAX   | UNIT |     |
|----------------------------|---|----------------------|------|---|------|-----|
| PVDD_x                     | Half-bridge supply  | 16                   | 32.5 | 34.1  | V    |     |
| GVDD_x                     | Supply for logic regulators and gate-drive circuitry                            | 10.8                 | 12   | 13.2  | V    |     |
| VDD                        | Digital regulator supply voltage  | 10.8                 | 12   | 13.2  | V    |     |
| R <sub>L</sub> (BTL)       | Load impedance  | 3.5                  | 4    | Output filter according to schematics in the application information section  | Ω    |     |
| R <sub>L</sub> (SE)        |   | 1.8                  | 2    |   |      |     |
| R <sub>L</sub> (PBTL)      |   | 1.6                  | 2    |   |      |     |
| R <sub>L</sub> (BTL)       | Load impedance  | 2.8                  | 3    | Output filter according to schematics in the application information section and add Schottky diodes on all output nodes to GND_X, ROC = 22kΩ | Ω    |     |
| L <sub>OUTPUT</sub> (BTL)  | Output filter inductance  | 7                    | 10   | Minimum output inductance at I <sub>OC</sub>  | μH   |     |
| L <sub>OUTPUT</sub> (SE)   |   | 7                    | 15   |   |      |     |
| L <sub>OUTPUT</sub> (PBTL) |   | 7                    | 10   |   |      |     |
| F <sub>PWM</sub>           | PWM frame rate selectable for AM interference avoidance; 1% Resistor tolerance. | Nominal              | 385  | 400   | 415  | kHz |
|                            |   | AM1                  | 315  | 333   | 350  |     |
|                            |   | AM2                  | 260  | 300   | 335  |     |
| R <sub>FREQ_ADJ</sub>      | PWM frame rate programming resistor   | Nominal; Master mode | 9.9  | 10  | 10.1 | kΩ  |
|                            |   | AM1; Master mode     | 19.8 | 20  | 20.2 |     |
|                            |   | AM2; Master mode     | 29.7 | 30  | 30.3 |     |
| C <sub>PVDD</sub>          | PVDD close decoupling capacitors  |                      | 2.0  |   | μF   |     |
| R <sub>OC</sub>            | Over-current programming resistor   |                      | 22   | 30  | kΩ   |     |
| R <sub>OC_LATCHED</sub>    | Over-current programming resistor   |                      | 47   | 64  | kΩ   |     |
| V <sub>FREQ_ADJ</sub>      | Voltage on FREQ_ADJ pin for slave mode operation                                |                      | 3.3  |   | V    |     |
| T <sub>J</sub>             | Junction temperature  | 0                    |      | 125   | °C   |     |

## PIN FUNCTIONS

| PIN       |                   | FUNCTION <sup>(1)</sup> | DESCRIPTION   |
|-----------|-------------------|-------------------------|---|
| NAME      | PHD NO.           |                         |   |
| AGND      | 8                 | P                       | Analog ground   |
| BST_A     | 54                | P                       | HS bootstrap supply (BST), external 0.033 μF capacitor to OUT_A required. |
| BST_B     | 41                | P                       | HS bootstrap supply (BST), external 0.033 μF capacitor to OUT_B required. |
| BST_C     | 40                | P                       | HS bootstrap supply (BST), external 0.033 μF capacitor to OUT_C required. |
| BST_D     | 27                | P                       | HS bootstrap supply (BST), external 0.033 μF capacitor to OUT_D required. |
| CLIP      | 18                | O                       | Clipping warning; open drain; active low                                  |
| C_STARTUP | 3                 | O                       | Startup ramp requires a charging capacitor of 4.7 nF to GND in BTL mode   |
| FREQ_ADJ  | 12                | I                       | PWM frame rate programming pin requires resistor to GND                   |
| GND       | 7, 23, 24, 57, 58 | P                       | Ground  |
| GND_A     | 48, 49            | P                       | Power ground for half-bridge A  |
| GND_B     | 46, 47            | P                       | Power ground for half-bridge B  |
| GND_C     | 34, 35            | P                       | Power ground for half-bridge C  |
| GND_D     | 32, 33            | P                       | Power ground for half-bridge D  |
| GVDD_A    | 55                | P                       | Gate drive voltage supply requires 0.1 μF capacitor to GND_A              |
| GVDD_B    | 56                | P                       | Gate drive voltage supply requires 0.1 μF capacitor to GND_B              |
| GVDD_C    | 25                | P                       | Gate drive voltage supply requires 0.1 μF capacitor to GND_C              |
| GVDD_D    | 26                | P                       | Gate drive voltage supply requires 0.1 μF capacitor to GND_D              |
| GVDD_AB   | —                 | P                       | Gate drive voltage supply requires 0.22 μF capacitor to GND_A/GND_B       |
| GVDD_CD   | —                 | P                       | Gate drive voltage supply requires 0.22 μF capacitor to GND_C/GND_D       |

(1) I = Input, O = Output, P = Power

**PIN FUNCTIONS (continued)**

| PIN                       |         | FUNCTION <sup>(1)</sup> | DESCRIPTION  |
|---------------------------|---------|-------------------------|--|
| NAME                      | PHD NO. |                         |  |
| INPUT_A                   | 4       | I                       | Input signal for half bridge A   |
| INPUT_B                   | 5       | I                       | Input signal for half bridge B   |
| INPUT_C                   | 10      | I                       | Input signal for half bridge C   |
| INPUT_D                   | 11      | I                       | Input signal for half bridge D   |
| M1                        | 20      | I                       | Mode selection   |
| M2                        | 21      | I                       | Mode selection   |
| M3                        | 22      | I                       | Mode selection   |
| NC                        | 59–62   | —                       | No connect, pins may be grounded.  |
| OC_ADJ                    | 1       | O                       | Analog overcurrent programming pin requires 30kΩ resistor to GND.  |
| OSC_IO+                   | 13      | I/O                     | Oscillator master/slave output/input.  |
| OSC_IO–                   | 14      | I/O                     | Oscillator master/slave output/input.  |
| $\overline{\text{OTW}}$   | —       | O                       | Overtemperature warning signal, open drain, active low.  |
| $\overline{\text{OTW1}}$  | 16      | O                       | Overtemperature warning signal, open drain, active low.  |
| $\overline{\text{OTW2}}$  | 17      | O                       | Overtemperature warning signal, open drain, active low.  |
| OUT_A                     | 52, 53  | O                       | Output, half bridge A  |
| OUT_B                     | 44, 45  | O                       | Output, half bridge B  |
| OUT_C                     | 36, 37  | O                       | Output, half bridge C  |
| OUT_D                     | 28, 29  | O                       | Output, half bridge D  |
| PSU_REF                   | 63      | P                       | PSU Reference requires close decoupling of 330 pF to GND   |
| PVDD_A                    | 50, 51  | P                       | Power supply input for half bridge A requires close decoupling of 2uF capacitor GND_A  |
| PVDD_B                    | 42, 43  | P                       | Power supply input for half bridge B requires close decoupling of 2uF capacitor GND_B  |
| PVDD_C                    | 38, 39  | P                       | Power supply input for half bridge C requires close decoupling of 2uF capacitor GND_C  |
| PVDD_D                    | 30, 31  | P                       | Power supply input for half bridge D requires close decoupling of 2uF capacitor GND_D  |
| READY                     | 19      | O                       | Normal operation; open drain; active high  |
| $\overline{\text{RESET}}$ | 2       | I                       | Device reset Input; active low   |
| $\overline{\text{SD}}$    | 15      | O                       | Shutdown signal, open drain, active low  |
| VDD                       | 64      | P                       | Power supply for digital voltage regulator requires a 10-μF capacitor in parallel with a 0.1-μF capacitor to GND for decoupling. |
| VI_CM                     | 6       | O                       | Analog comparator reference node requires close decoupling of 1nF to GND   |
| VREG                      | 9       | P                       | Digital regulator supply filter pin requires 0.1-μF capacitor to GND   |

**TYPICAL SYSTEM BLOCK DIAGRAM**

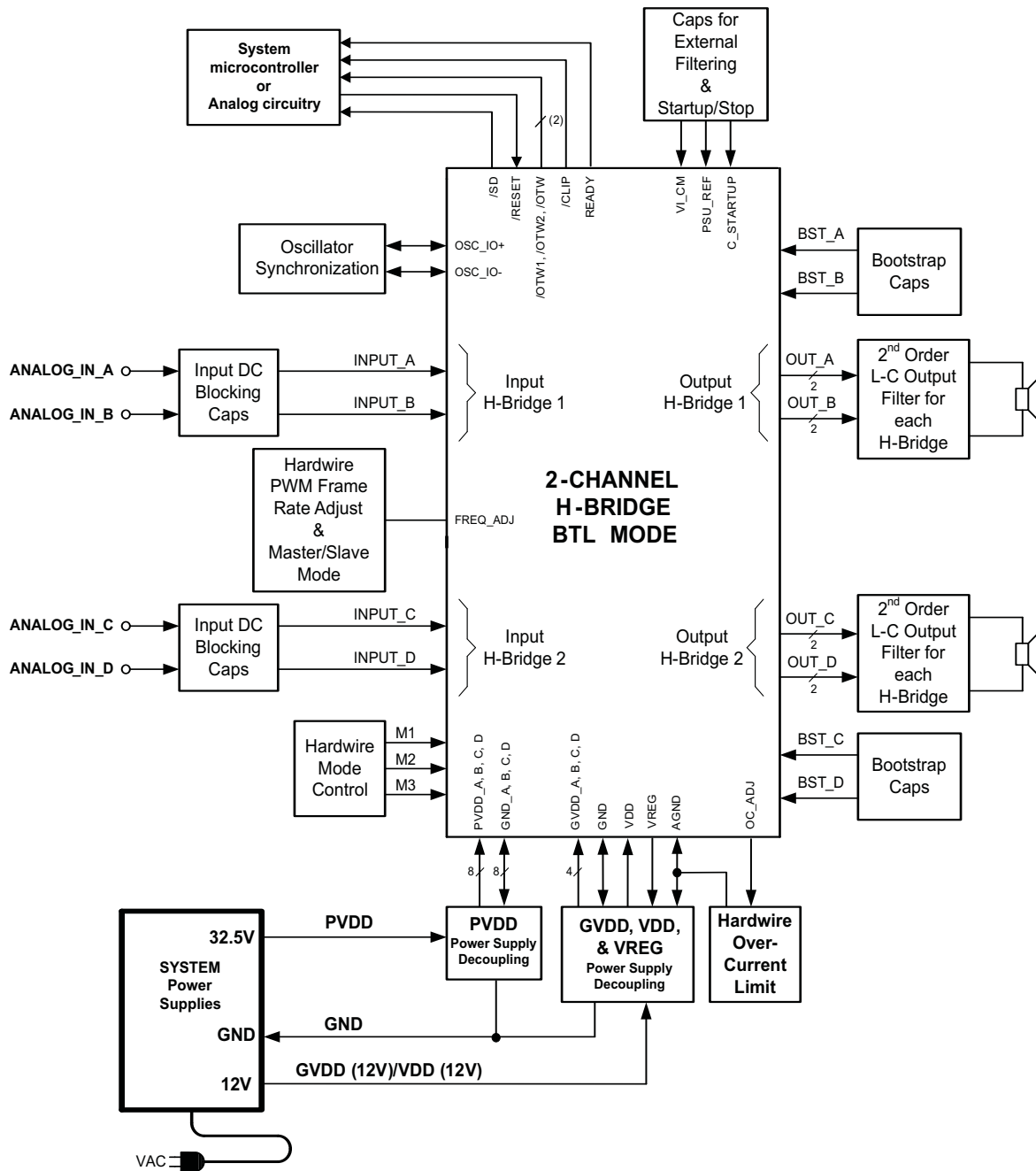

FUNCTIONAL BLOCK DIAGRAM

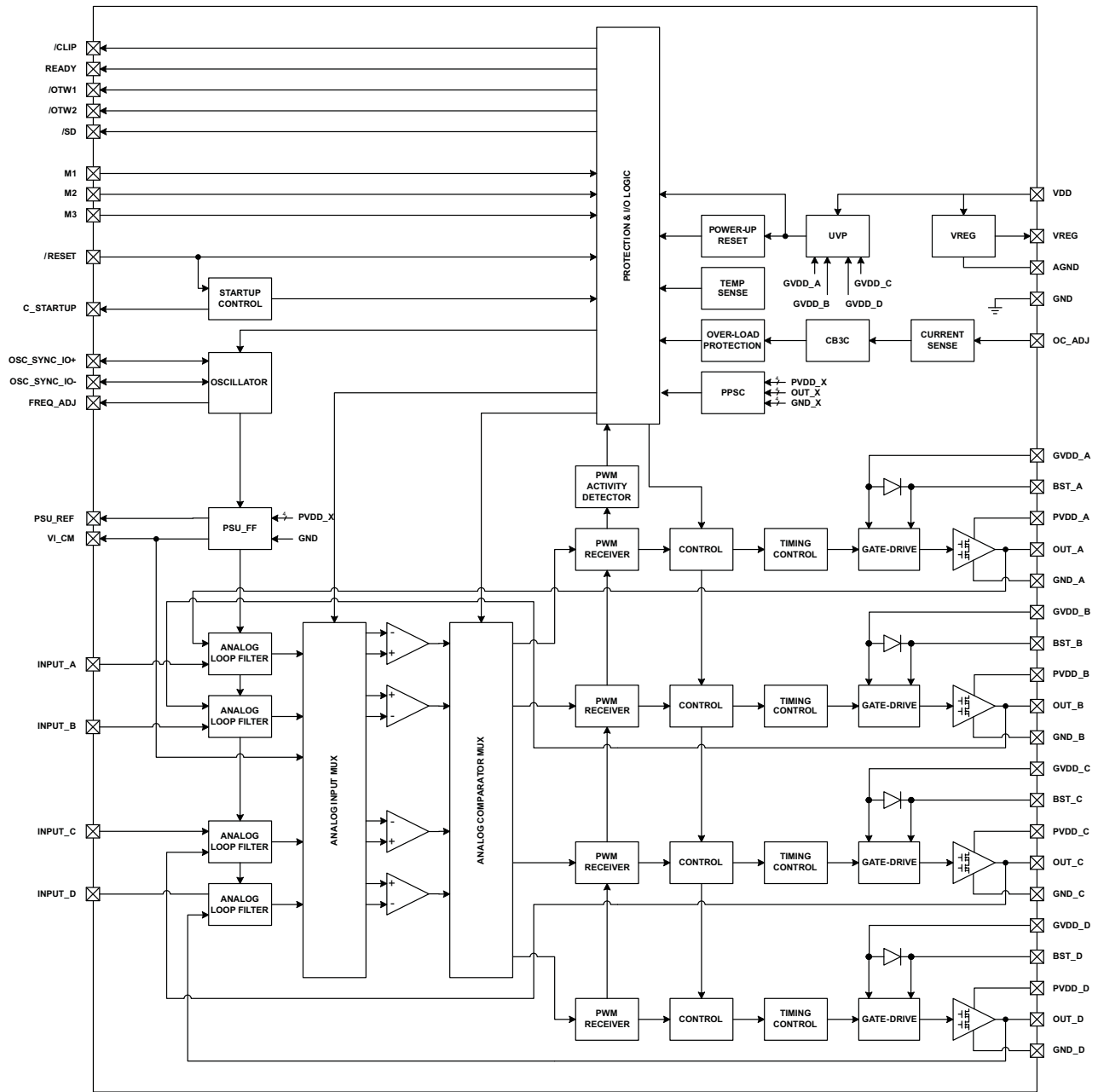

## AUDIO CHARACTERISTICS (BTL)

PCB and system configuration are in accordance with recommended guidelines. Audio frequency = 1kHz, PVDD\_X = 32.5V, GVDD\_X = 12 V, R<sub>L</sub> = 4Ω, f<sub>S</sub> = 400kHz, R<sub>OC</sub> = 30kΩ, T<sub>C</sub> = 75°C, Output Filter: L<sub>DEM</sub> = 7μH, C<sub>DEM</sub> = 680nF, MODE = 010, unless otherwise noted.

| PARAMETER         |   | TEST CONDITIONS  | MIN | TYP   | MAX | UNIT |
|-------------------|---|--|-----|-------|-----|------|
| P <sub>O</sub>    | Power output per channel                                    | R <sub>L</sub> = 3 Ω, 10% THD+N (add Schottky diodes on all output nodes OUT_X to GND_X, ROC = 22kΩ) |     | 165   |     | W    |
|                   |   | R <sub>L</sub> = 4 Ω, 10% THD+N  |     | 125   |     |      |
|                   |   | R <sub>L</sub> = 3 Ω, 1% THD+N (add Schottky diodes on all output nodes OUT_X to GND_X, ROC = 22kΩ)  |     | 130   |     |      |
|                   |   | R <sub>L</sub> = 4 Ω, 1% THD+N   |     | 105   |     |      |
| THD+N             | Total harmonic distortion + noise                           | 1 W  |     | 0.03% |     |      |
| V <sub>n</sub>    | Output integrated noise                                     | A-weighted, AES17 filter, Input Capacitor Grounded   |     | 168   |     | μV   |
| V <sub>OS</sub>   | Output offset voltage                                       | Inputs AC coupled to GND   |     | 5     | 18  | mV   |
| SNR               | Signal-to-noise ratio <sup>(1)</sup>                        | A-weighted, AES17 filter   |     | 100   |     | dB   |
| DNR               | Dynamic range   | A-weighted, AES17 filter   |     | 100   |     | dB   |
| P <sub>idle</sub> | Power dissipation due to Idle losses (I <sub>PVDD_X</sub> ) | P <sub>O</sub> = 0, 4 channels switching <sup>(2)</sup>  |     | 1.3   |     | W    |

(1) SNR is calculated relative to 1% THD+N output level..

(2) Actual system idle losses also are affected by core losses of output inductors.

## AUDIO CHARACTERISTICS (PBTL)

PCB and system configuration are in accordance with recommended guidelines. Audio frequency = 1kHz, PVDD\_X = 32.5V, GVDD\_X = 12 V, R<sub>L</sub> = 2Ω, f<sub>S</sub> = 400kHz, R<sub>OC</sub> = 30kΩ, T<sub>C</sub> = 75°C, Output Filter: L<sub>DEM</sub> = 7 μH, C<sub>DEM</sub> = 1.5 μF, MODE = 101-10, unless otherwise noted.

| PARAMETER         |  | TEST CONDITIONS   | MIN | TYP   | MAX | UNIT |
|-------------------|--|---|-----|-------|-----|------|
| P <sub>O</sub>    | Power output per channel                       | R <sub>L</sub> = 2 Ω, 10% THD+N                         |     | 250   |     | W    |
|                   |  | R <sub>L</sub> = 3 Ω, 10% THD+N                         |     | 165   |     |      |
|                   |  | R <sub>L</sub> = 4 Ω, 10% THD+N                         |     | 125   |     |      |
|                   |  | R <sub>L</sub> = 2 Ω, 1% THD+N                          |     | 210   |     |      |
|                   |  | R <sub>L</sub> = 3 Ω, 1% THD+N                          |     | 135   |     |      |
|                   |  | R <sub>L</sub> = 4 Ω, 1% THD+N                          |     | 105   |     |      |
| THD+N             | Total harmonic distortion + noise              | 1 W   |     | 0.03% |     |      |
| V <sub>n</sub>    | Output integrated noise                        | A-weighted  |     | 170   |     | μV   |
| SNR               | Signal to noise ratio <sup>(1)</sup>           | A-weighted  |     | 100   |     | dB   |
| DNR               | Dynamic range                                  | A-weighted  |     | 100   |     | dB   |
| P <sub>idle</sub> | Power dissipation due to idle losses (IPVDD_X) | P <sub>O</sub> = 0, 4 channels switching <sup>(2)</sup> |     | 1.3   |     | W    |

(1) SNR is calculated relative to 1% THD-N output level.

(2) Actual system idle losses are affected by core losses of output inductors.

**ELECTRICAL CHARACTERISTICS**

 PVDD\_X = 32.5V, GVDD\_X = 12 V, VDD = 12 V, T<sub>C</sub> (Case temperature) = 75°C, f<sub>s</sub> = 400 kHz, unless otherwise specified.

| PARAMETER   |  | TEST CONDITIONS   | MIN  | TYP  | MAX  | UNIT |
|---|--|---|------|------|------|------|
| <b>INTERNAL VOLTAGE REGULATOR AND CURRENT CONSUMPTION</b> |  |   |      |      |      |      |
| VREG  | Voltage regulator, only used as reference node, VREG | VDD = 12 V  | 3    | 3.3  | 3.6  | V    |
| VI_CM   | Analog comparator reference node, VI_CM              |   | 1.5  | 1.75 | 1.9  | V    |
| I <sub>VDD</sub>  | VDD supply current                                   | Operating, 50% duty cycle   | 20   |      |      | mA   |
|   |  | Idle, reset mode  | 20   |      |      |      |
| I <sub>GVDD_X</sub>                                       | GVDD_x gate-supply current per half-bridge           | 50% duty cycle  | 10   |      |      | mA   |
|   |  | Reset mode  | 1.5  |      |      |      |
| I <sub>PVDD_X</sub>                                       | Half-bridge supply current                           | 50% duty cycle with recommended output filter                         | 10   |      |      | mA   |
|   |  | Reset mode, No switching  | 540  |      |      |      |
| <b>ANALOG INPUTS</b>                                      |  |   |      |      |      |      |
| R <sub>IN</sub>   | Input resistance                                     | READY = HIGH  | 33   |      |      | kΩ   |
| V <sub>IN</sub>   | Maximum input voltage swing                          |   | 7    |      |      | V    |
| I <sub>IN</sub>   | Maximum input current                                |   | 1    |      |      | mA   |
| G   | Voltage Gain (V <sub>OUT</sub> /V <sub>IN</sub> )    |   | 20   |      |      | dB   |
| <b>OSCILLATOR</b>   |  |   |      |      |      |      |
| f <sub>OSC_IO+</sub>                                      | Nominal, Master Mode                                 | F <sub>PWM</sub> × 10   | 3.85 | 4    | 4.15 | MHz  |
|   | AM1, Master Mode                                     |   | 3.15 | 3.33 | 3.5  |      |
|   | AM2, Master Mode                                     |   | 2.6  | 3    | 3.35 |      |
| V <sub>IH</sub>   | High level input voltage                             |   | 1.86 |      |      | V    |
| V <sub>IL</sub>   | Low level input voltage                              |   | 1.45 |      |      | V    |
| <b>OUTPUT-STAGE MOSFETS</b>                               |  |   |      |      |      |      |
| R <sub>DS(on)</sub>                                       | Drain-to-source resistance, low side (LS)            | T <sub>J</sub> = 25°C, excludes metallization resistance, GVDD = 12 V | 60   | 100  | mΩ   |      |
|   | Drain-to-source resistance, high side (HS)           |   | 60   | 100  | mΩ   |      |

**ELECTRICAL CHARACTERISTICS (continued)**

PVDD\_X = 32.5V, GVDD\_X = 12 V, VDD = 12 V, T<sub>C</sub> (Case temperature) = 75°C, f<sub>s</sub> = 400 kHz, unless otherwise specified.

| PARAMETER                            |   | TEST CONDITIONS  | MIN | TYP  | MAX | UNIT    |
|--------------------------------------|---|--|-----|------|-----|---------|
| <b>I/O PROTECTION</b>                |   |  |     |      |     |         |
| V <sub>uvp,G</sub>                   | Undervoltage protection limit, GVDD_x and VDD   |  |     | 9.5  |     | V       |
| V <sub>uvp,hyst</sub> <sup>(1)</sup> |   |  |     | 0.6  |     | V       |
| OTW1 <sup>(1)</sup>                  | Overtemperature warning 1   |  | 95  | 100  | 105 | °C      |
| OTW2 <sup>(1)</sup>                  | Overtemperature warning 2   |  | 115 | 125  | 135 | °C      |
| OTW <sub>hyst</sub> <sup>(1)</sup>   | Temperature drop needed below OTW temperature for $\overline{OTW}$ to be inactive after $\overline{OTW}$ event. |  |     | 25   |     | °C      |
| OTE <sup>(1)</sup>                   | Overtemperature error   |  | 145 | 155  | 165 | °C      |
|                                      | OTE-OTW differential  |  |     | 30   |     | °C      |
| OTE <sub>hyst</sub> <sup>(1)</sup>   | A reset needs to occur for $\overline{SD}$ to be released following an OTE event                                |  |     | 25   |     | °C      |
| OLPC                                 | Overload protection counter   | f <sub>PWM</sub> = 400 kHz   |     | 2.6  |     | ms      |
| I <sub>OC</sub>                      | Overcurrent limit protection  | Resistor – programmable, nominal peak current in 1Ω load, R <sub>OCP</sub> = 30kΩ  |     | 12.6 |     | A       |
|                                      |   | Resistor – programmable, nominal peak current in 1Ω load, R <sub>OCP</sub> = 22kΩ (add Schottky diodes on all output nodes OUT_X to GND_X) |     | 16.3 |     | A       |
| I <sub>OC_LATCHED</sub>              | Overcurrent limit protection  | Resistor – programmable, nominal peak current in 1Ω load, R <sub>OCP</sub> = 64kΩ  |     | 12.6 |     | A       |
|                                      |   | Resistor – programmable, nominal peak current in 1Ω load, R <sub>OCP</sub> = 47kΩ (add Schottky diodes on all output nodes OUT_X to GND_X) |     | 16.3 |     | A       |
| I <sub>OCT</sub>                     | Overcurrent response time   | Time from switching transition to flip-state induced by overcurrent  |     | 150  |     | ns      |
| I <sub>PD</sub>                      | Internal pulldown resistor at output of each half bridge  | Connected when $\overline{RESET}$ is active to provide bootstrap charge. Not used in SE mode.  |     | 3    |     | mA      |
| <b>STATIC DIGITAL SPECIFICATIONS</b> |   |  |     |      |     |         |
| V <sub>IH</sub>                      | High level input voltage  | INPUT_X, M1, M2, M3, RESET   | 1.9 |      |     | V       |
| V <sub>IL</sub>                      | Low level input voltage   |  |     | 0.8  |     | V       |
| I <sub>lkg</sub>                     | Input leakage current   |  |     | 100  |     | μA      |
| <b>OTW/SHUTDOWN (SD)</b>             |   |  |     |      |     |         |
| R <sub>INT_PU</sub>                  | Internal pullup resistance, $\overline{OTW1}$ to VREG, $\overline{OTW2}$ to VREG, $\overline{SD}$ to VREG       |  | 20  | 26   | 32  | kΩ      |
| V <sub>OH</sub>                      | High level output voltage   | Internal pullup resistor   | 3   | 3.3  | 3.6 | V       |
|                                      |   | External pullup of 4.7 kΩ to 5 V   | 4.5 |      | 5   |         |
| V <sub>OL</sub>                      | Low level output voltage  | I <sub>O</sub> = 4 mA  |     | 200  | 500 | mV      |
| FANOUT                               | Device fanout $\overline{OTW1}$ , $\overline{OTW2}$ , $\overline{SD}$ , $\overline{CLIP}$ , $\overline{READY}$  | No external pullup   |     | 30   |     | devices |

(1) Specified by design.

TYPICAL CHARACTERISTICS, BTL CONFIGURATION

TOTAL HARMONIC+NOISE  
vs  
OUTPUT POWER

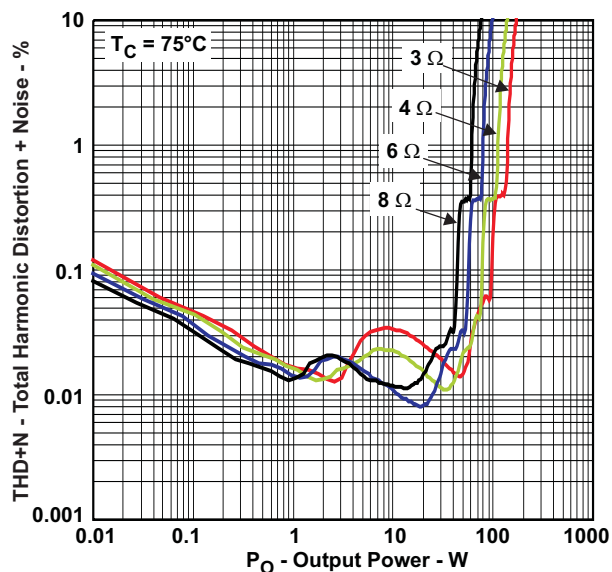

Figure 1.

OUTPUT POWER  
vs  
SUPPLY VOLTAGE

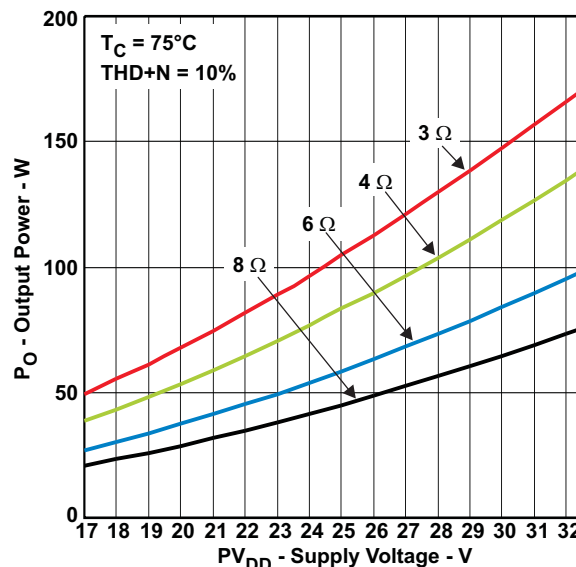

Figure 2.

UNCLIPPED OUTPUT POWER  
vs  
SUPPLY VOLTAGE

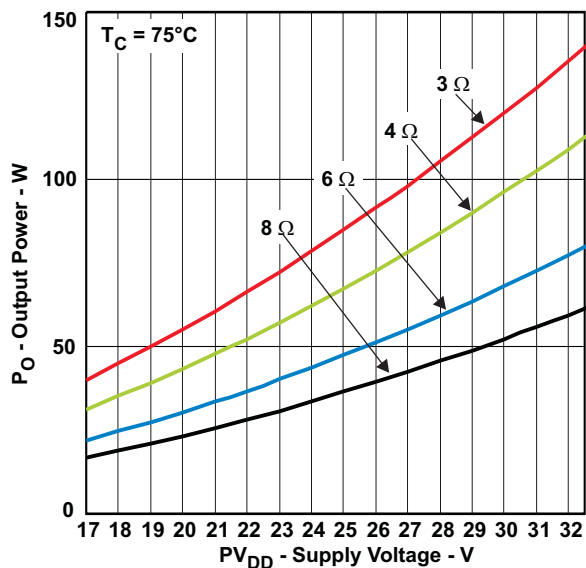

Figure 3.

SYSTEM EFFICIENCY  
vs  
OUTPUT POWER

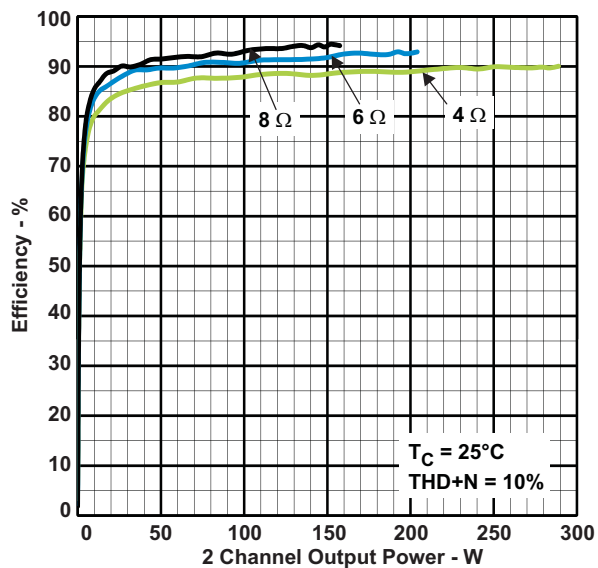

Figure 4.

**TYPICAL CHARACTERISTICS, BTL CONFIGURATION (continued)**

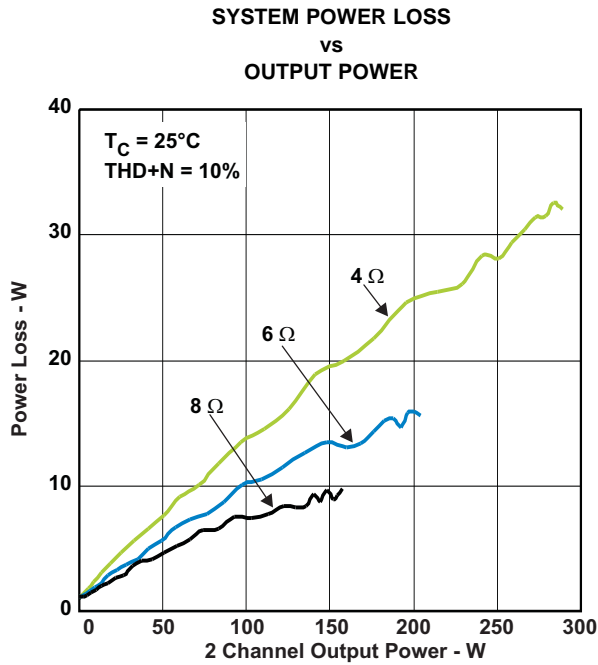

Figure 5.

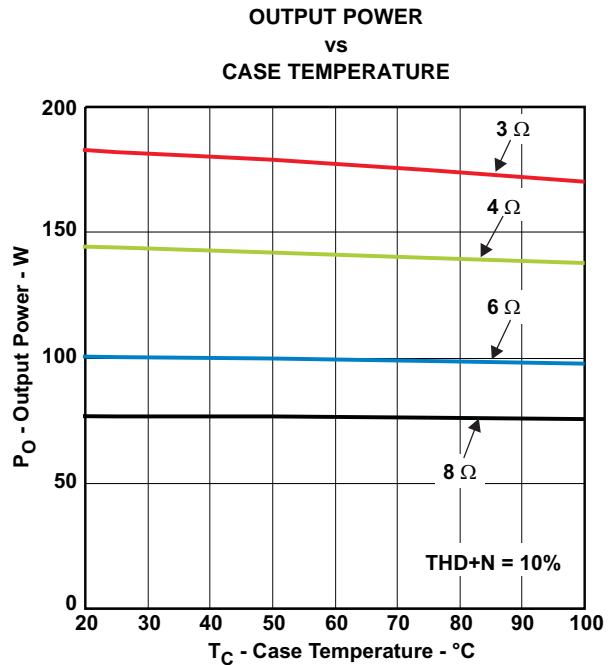

Figure 6.

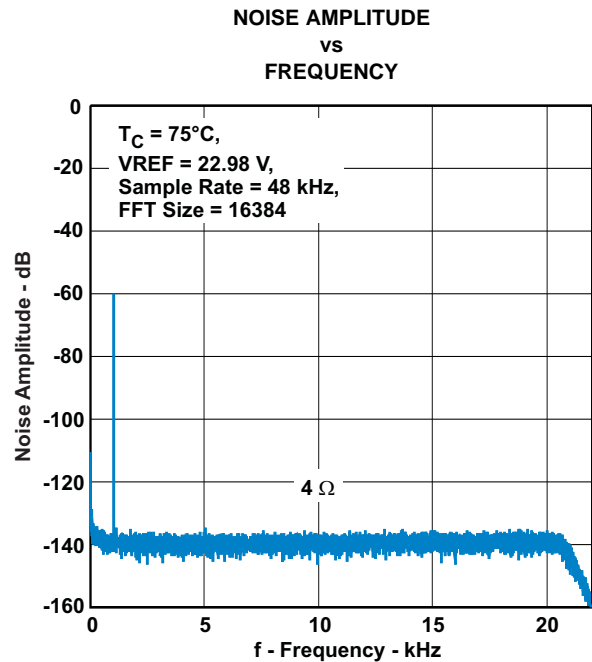

Figure 7.

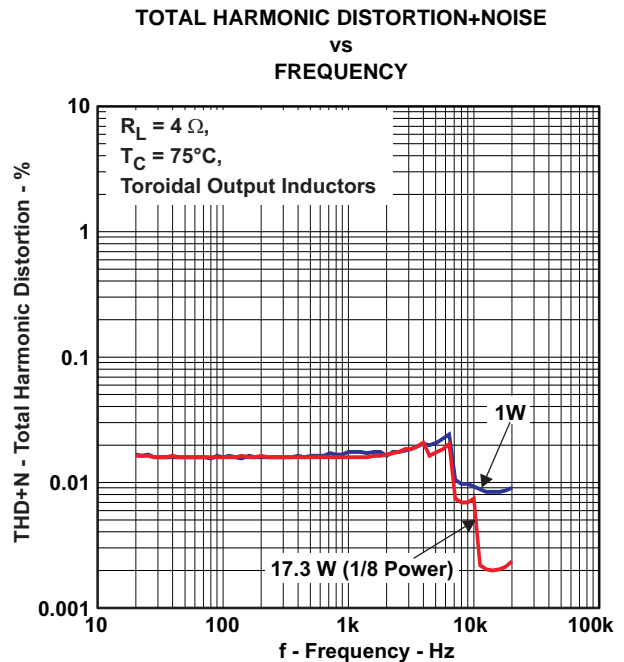

Figure 8.

TYPICAL CHARACTERISTICS, PBTL CONFIGURATION

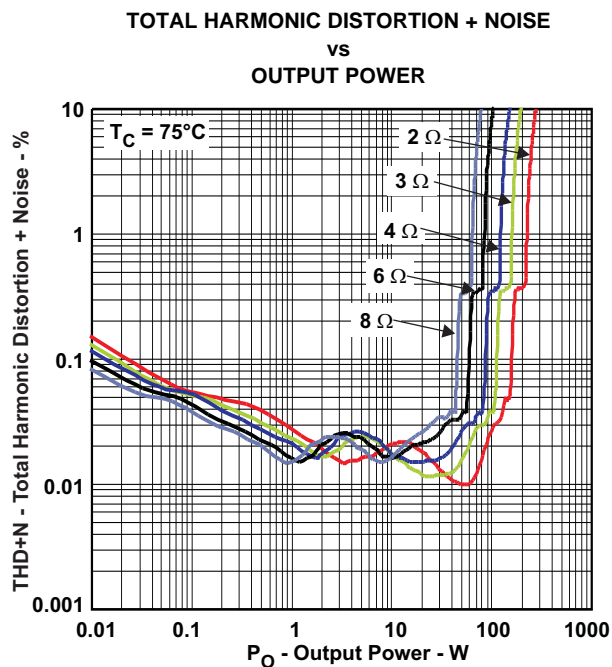

Figure 9.

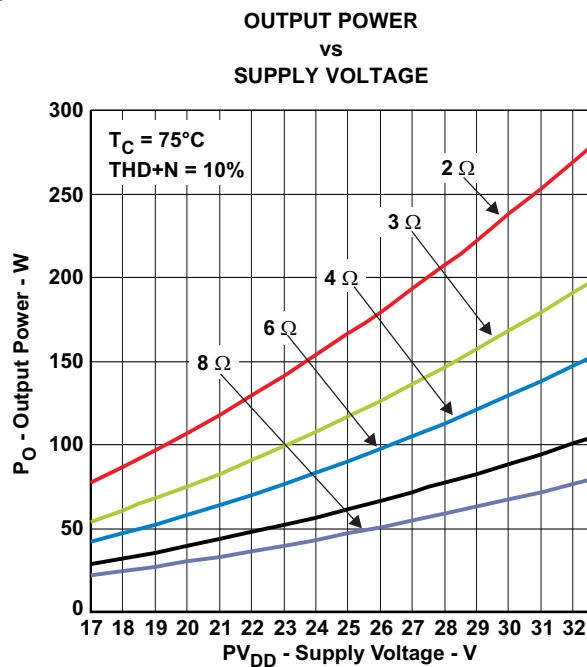

Figure 10.

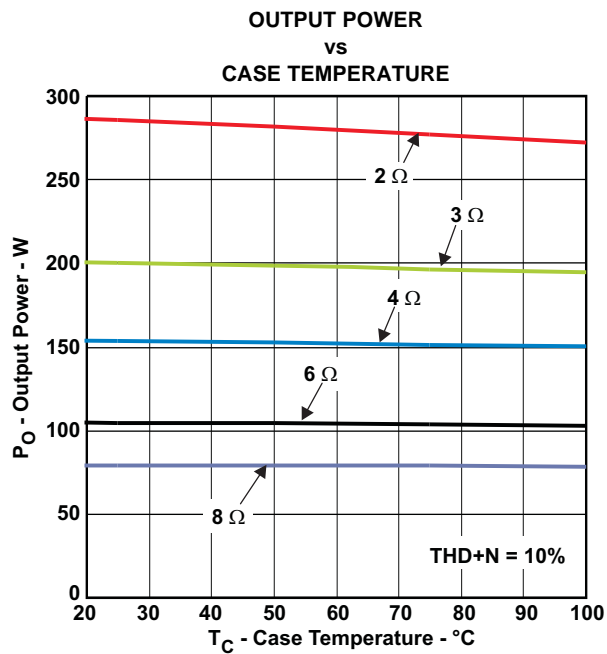

Figure 11.

## APPLICATION INFORMATION

### PCB MATERIAL RECOMMENDATION

FR-4 Glass Epoxy material with 2 oz. (70 $\mu$ m) is recommended for use with the TAS5611A. The use of this material can provide for higher power output, improved thermal performance, and better EMI margin (due to lower PCB trace inductance).

### PVDD CAPACITOR RECOMMENDATION

The large capacitors used in conjunction with each full-bridge, are referred to as the PVDD Capacitors. These capacitors should be selected for proper voltage margin and adequate capacitance to support the power requirements. In practice, with a well designed system power supply, 1000 $\mu$ F, 50V will support more applications. The PVDD capacitors should be low ESR type because they are used in a circuit associated with high-speed switching.

### DECOUPLING CAPACITOR RECOMMENDATIONS

To design an amplifier that has robust performance, passes regulatory requirements, and exhibits good audio performance, a quality decoupling capacitors should be used. In practice, X7R should be used in this application.

The voltage of the decoupling capacitors should be selected in accordance with good design practices. Temperature, ripple current, and voltage overshoot must be considered. This fact is particularly true in the selection of the 2 $\mu$ F that is placed on the power supply to each half-bridge. It must withstand the voltage overshoot of the PWM switching, the heat generated by the amplifier during high power output, and the ripple current created by high power output. A minimum voltage rating of 50V is required for use with a 32.5V power supply.

### SYSTEM DESIGN RECOMMENDATIONS

The following schematics and PCB layouts illustrate *best practices* used for the TAS5611A.

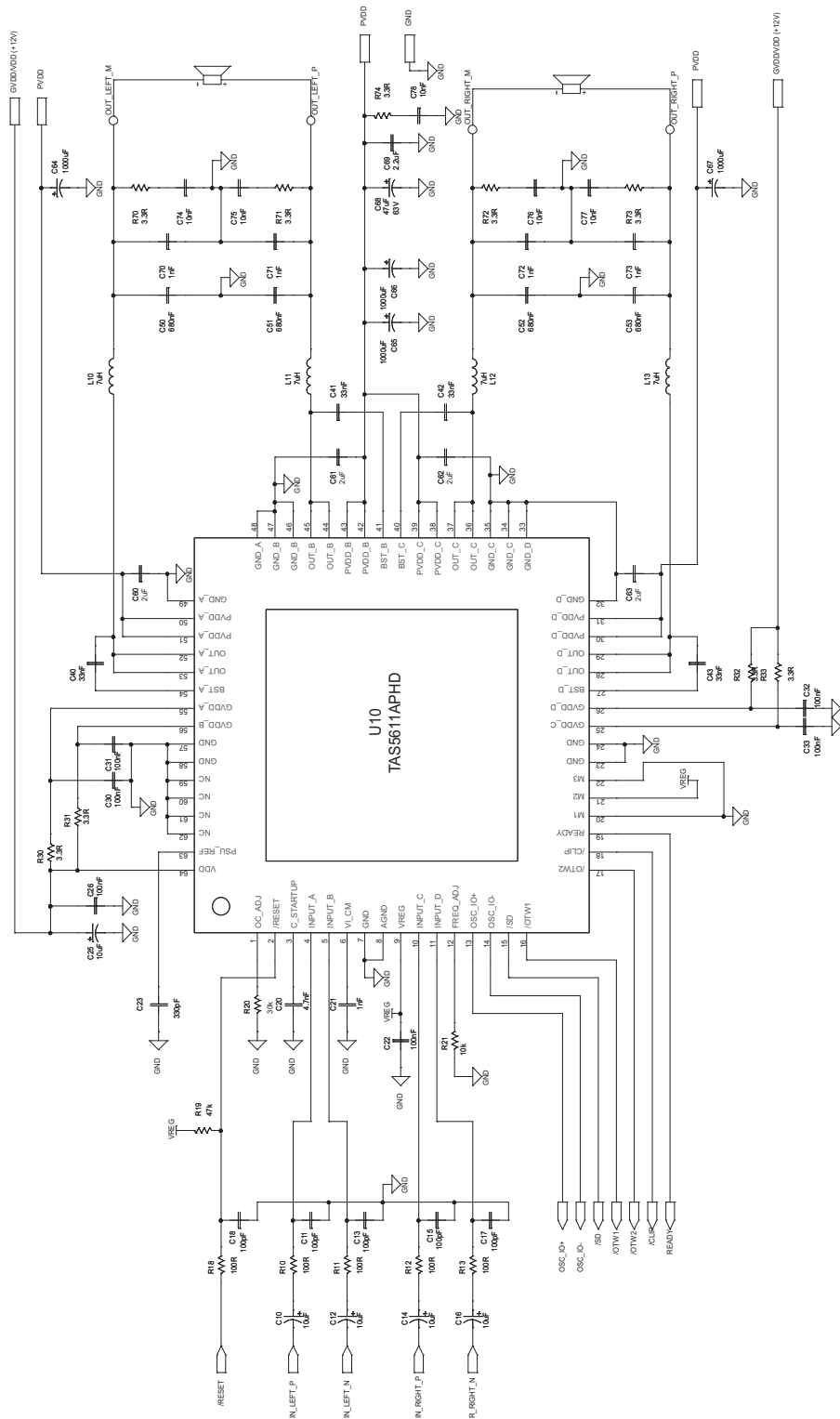

Figure 12. Typical Differential Input BTL Application With BD Modulation Filters



## THEORY OF OPERATION

### POWER SUPPLIES

To facilitate system design, the TAS5611A needs only a 12V supply in addition to the (typical) 32.5V power-stage supply. An internal voltage regulator provides suitable voltage levels for the digital and low-voltage analog circuitry. Additionally, all circuitry requiring a floating voltage supply, e.g., the high-side gate drive, is accommodated by built-in bootstrap circuitry requiring only an external capacitor for each half-bridge.

To provide outstanding electrical and acoustical characteristics, the PWM signal path including gate drive and output stage is designed as identical, independent half-bridges. For this reason, each half-bridge has separate gate drive supply (GVDD\_X), bootstrap pins (BST\_X), and power-stage supply pins (PVDD\_X). Furthermore, an additional pin (VDD) is provided as supply for all common circuits. Although supplied from the same 12V source, it is highly recommended to separate GVDD\_A, GVDD\_B, GVDD\_C, GVDD\_D, and VDD on the printed-circuit board (PCB) by RC filters (see application diagram for details). These RC filters provide the recommended high-frequency isolation. Special attention should be paid to placing all decoupling capacitors as close to their associated pins as possible. In general, inductance between the power supply pins and decoupling capacitors must be avoided. (See reference board documentation for additional information.)

For a properly functioning bootstrap circuit, a small ceramic capacitor must be connected from each bootstrap pin (BST\_X) to the power-stage output pin (OUT\_X). When the power-stage output is low, the bootstrap capacitor is charged through an internal diode connected between the gate-drive power-supply pin (GVDD\_X) and the bootstrap pin. When the powerstage output is high, the bootstrap capacitor potential is shifted above the output potential and thus provides a suitable voltage supply for the high-side gate driver. In an application with PWM switching frequencies in the range from 300kHz to 400kHz, it is recommended to use 33nF ceramic capacitors, size 0603 or 0805, for the bootstrap supply. These 33nF capacitors ensure sufficient energy storage, even during minimal PWM duty cycles, to keep the high-side power stage FET (LDMOS) fully turned on during the remaining part of the PWM cycle.

Special attention should be paid to the power-stage power supply; this includes component selection, PCB placement, and routing. As indicated, each half-bridge has independent power-stage supply pins (PVDD\_X). For optimal electrical performance, EMI compliance, and system reliability, it is important that each PVDD\_X pin is decoupled with a 2 $\mu$ F ceramic capacitor placed as close as possible to each supply pin. It is recommended to follow the PCB layout of the TAS5611A reference design. For additional information on recommended power supply and required components, see the application diagrams in this data sheet.

The 12V supply should be from a low-noise, low-output impedance voltage regulator. Likewise, the 32.5V power-stage supply is assumed to have low output impedance and low noise. The power-supply sequence is not critical as facilitated by the internal power-on-reset circuit. Moreover, the TAS5611A is fully protected against erroneous power-stage turn on due to parasitic gate charging. Thus, voltage-supply ramp rates (dV/dt) are non-critical within the specified range (see the [Recommended Operating Conditions](#) table of this data sheet).

### SYSTEM POWER-UP/POWER-DOWN SEQUENCE

#### Powering Up

The TAS5611A does not require a power-up sequence. The outputs of the H-bridges remain in a high-impedance state until the gate-drive supply voltage (GVDD\_X) and VDD voltage are above the undervoltage protection (UVP) voltage threshold (see the [Electrical Characteristics](#) table of this data sheet). Although not specifically required, it is recommended to hold RESET in a low state while powering up the device. This allows an internal circuit to charge the external bootstrap capacitors by enabling a weak pulldown of the half-bridge output.

#### Powering Down

The TAS5611A does not require a power-down sequence. The device remains fully operational as long as the gate-drive supply (GVDD\_X) voltage and VDD voltage are above the undervoltage protection (UVP) voltage threshold (see the [Electrical Characteristics](#) table of this data sheet). Although not specifically required, it is a good practice to hold RESET low during power down, thus preventing audible artifacts including pops or clicks.

## ERROR REPORTING

The  $\overline{SD}$ ,  $\overline{OTW}$ ,  $\overline{OTW1}$  and  $\overline{OTW2}$  pins are active low, open-drain outputs. Their function is for protection-mode signaling to a PWM controller or other system-control device.

Any fault resulting in device shutdown is signaled by the  $\overline{SD}$  pin going low. Likewise,  $\overline{OTW}$  and  $\overline{OTW2}$  goes low when the device junction temperature exceeds 125°C and  $\overline{OTW1}$  goes low when the junction temperature exceeds 100°C (see the following table).

| $\overline{SD}$ | $\overline{OTW1}$ | $\overline{OTW2}$ ,<br>$\overline{OTW}$ | DESCRIPTION  |
|-----------------|-------------------|---|--|
| 0               | 0                 | 0                                       | Overtemperature (OTE) or overload (OLP) or undervoltage (UVP)  |
| 0               | 0                 | 1                                       | Overload (OLP) or undervoltage (UVP). Junction temperature higher than 100°C (overtemperature warning) |
| 0               | 1                 | 1                                       | Overload (OLP) or undervoltage (UVP)   |
| 1               | 0                 | 0                                       | Junction temperature higher than 125°C (overtemperature warning)                                       |
| 1               | 0                 | 1                                       | Junction temperature higher than 100°C (overtemperature warning)                                       |
| 1               | 1                 | 1                                       | Junction temperature lower than 100°C and no OLP or UVP faults (normal operation)                      |

Note that asserting either  $\overline{RESET}$  low forces the  $\overline{SD}$  signal high, independent of faults being present. TI recommends monitoring the  $\overline{OTW}$  signal using the system microcontroller and responding to an overtemperature warning signal by, e.g., turning down the volume to prevent further heating of the device resulting in device shutdown (OTE).

To reduce external component count, an internal pullup resistor to 3.3V is provided on both  $\overline{SD}$  and  $\overline{OTW}$  outputs. Level compliance for 5V logic can be obtained by adding external pullup resistors to 5V (see the [Electrical Characteristics](#) table of this data sheet for further specifications).

## DEVICE PROTECTION SYSTEM

The TAS5611A contains advanced protection circuitry carefully designed to facilitate system integration and ease of use, as well as to safeguard the device from permanent failure due to a wide range of fault conditions such as short circuits, overload, overtemperature, and undervoltage. The TAS5611A responds to a fault by immediately setting the power stage in a high-impedance (Hi-Z) state and asserting the  $\overline{SD}$  pin low. In situations other than overload and overtemperature error (OTE), the device automatically recovers when the fault condition has been removed, i.e., the supply voltage has increased.

The device will function on errors, as shown in the following table.

| BTL Mode       |                 | PBTL Mode      |                 | SE Mode        |                 |
|----------------|-----------------|----------------|-----------------|----------------|-----------------|
| Local error in | Turns Off or in | Local error in | Turns Off or in | Local error in | Turns Off or in |
| A              | A+B             | A              | A+B+C+D         | A              | A+B             |
| B              |                 | B              |                 | B              |                 |
| C              | C+D             | C              |                 | C              | C+D             |
| D              |                 | D              |                 | D              |                 |

Bootstrap UVP does not shutdown according to the table, it shuts down the respective halfbridge.

## PIN-TO-PIN SHORT CIRCUIT PROTECTION (PPSC)

The PPSC detection system protects the device from permanent damage if a power output pin (OUT\_X) is shorted to GND\_X or PVDD\_X. For comparison, the OC protection system detects an over current after the demodulation filter where PPSC detects shorts directly at the pin before the filter. PPSC detection is performed at startup i.e. when VDD is supplied, consequently a short to either GND\_X or PVDD\_X after system startup will not activate the PPSC detection system. When PPSC detection is activated by a short on the output, all half bridges are kept in a Hi-Z state until the short is removed, the device then continues the startup sequence and starts switching. The detection is controlled globally by a two step sequence. The first step ensures that there are no shorts from OUT\_X to GND\_X, the second step tests that there are no shorts from OUT\_X to PVDD\_X. The total duration of this process is roughly proportional to the capacitance of the output LC filter. The typical duration is

<15ms/μF. While the PPSC detection is in progress,  $\overline{SD}$  is kept low, and the device will not react to changes applied to the  $\overline{RESET}$  pins. If no shorts are present the PPSC detection passes, and  $\overline{SD}$  is released. A device reset will not start a new PPSC detection. PPSC detection is enabled in BTL and PBTL output configurations, the detection is not performed in SE mode. To make sure the PPSC detection system is not tripped, it is recommended not to insert resistive load to GND\_X or PVDD\_X.

## OVERTEMPERATURE PROTECTION

### PHD Package:

The TAS5611A PHD package option has a three-level temperature-protection system that asserts an active low warning signal ( $\overline{OTW1}$ ) when the device junction temperature exceeds 100°C (typical), ( $\overline{OTW2}$ ) when the device junction temperature exceeds 125°C (typical) and, if the device junction temperature exceeds 155°C (typical), the device is put into thermal shutdown, resulting in all half-bridge outputs being set in the high-impedance (Hi-Z) state and  $\overline{SD}$  being asserted low. OTE is latched in this case. To clear the OTE latch,  $\overline{RESET}$  must be asserted. Thereafter, the device resumes normal operation.

## UNDERVOLTAGE PROTECTION (UVP) AND POWER-ON RESET (POR)

The UVP and POR circuits of the TAS5611A fully protect the device in any power-up/down and brownout situation. While powering up, the POR circuit resets the overload circuit (OLP) and ensures that all circuits are fully operational when the GVDD\_X and VDD supply voltages reach stated in the [Electrical Characteristics](#) table. Although GVDD\_X and VDD are independently monitored, a supply voltage drop below the UVP threshold on any VDD or GVDD\_X pin results in all half-bridge outputs immediately being set in the high-impedance (Hi-Z) state and  $\overline{SD}$  being asserted low. The device automatically resumes operation when all supply voltages have increased above the UVP threshold.

## DEVICE RESET

When  $\overline{RESET}$  is asserted low, all power-stage FETs in the four half-bridges are forced into a high-impedance (Hi-Z) state.

In BTL modes, to accommodate bootstrap charging prior to switching start, asserting the reset input low enables weak pulldown of the half-bridge outputs. In the SE mode, the output is forced into a high impedance state when asserting the reset input low. Asserting reset input low removes any fault information to be signaled on the  $\overline{SD}$  output, i.e.,  $\overline{SD}$  is forced high. A rising-edge transition on reset input allows the device to resume operation after an overload fault. To ensure thermal reliability, the rising edge of reset must occur no sooner than 4 ms after the falling edge of  $\overline{SD}$ .

## SYSTEM DESIGN CONSIDERATION

A rising-edge transition on reset input allows the device to execute the startup sequence and starts switching.

Apply only audio when the state of  $\overline{READY}$  is high that will start and stop the amplifier without having audible artifacts that is heard in the output transducers. If an overcurrent protection event is introduced the  $\overline{READY}$  signal goes low, hence, filtering is needed if the signal is intended for audio muting in non microcontroller systems.

The CLIP signal is indicating that the output is approaching clipping. The signal can be used to either an audio volume decrease or intelligent power supply controlling a low and a high rail.

The device is inverting the audio signal from input to output.

The VREG pin is not recommended to be used as a voltage source for external circuitry.

## OSCILLATOR

The oscillator frequency can be trimmed by external control of the  $\overline{FREQ\_ADJ}$  pin.

To reduce interference problems while using radio receiver tuned within the AM band, the switching frequency can be changed from nominal to lower values. These values should be chosen such that the nominal and the lower value switching frequencies together results in the fewest cases of interference throughout the AM band, and can be selected by the value of the  $\overline{FREQ\_ADJ}$  resistor connected to GND in master mode.

For slave mode operation, turn of the oscillator by pulling the  $\overline{FREQ\_ADJ}$  pin to VREG. This will configure the  $\overline{OSC\_I/O}$  pins as inputs and needs to be slaved from an external clock.

## PRINTED CIRCUIT BOARD RECOMMENDATION

Use an unbroken ground plane to have good low impedance and inductance return path to the power supply for power and audio signals. PCB layout, audio performance and EMI are linked closely together. The circuit contains high fast switching currents; therefore, care must be taken to prevent damaging voltage spikes. Routing the audio input should be kept short and together with the accompanied audio source ground. A local ground area underneath the device is important to keep solid to minimize ground bounce.

Netlist for this printed circuit board is generated from the schematic in [Figure 12](#).

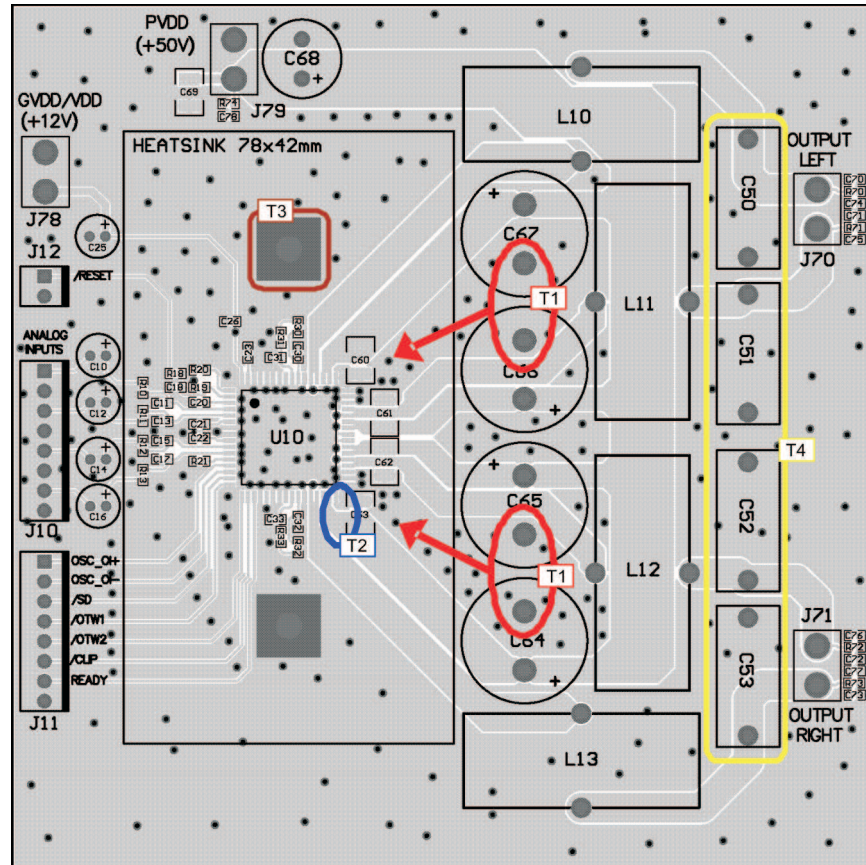

**Note T1:** PVDD decoupling bulk capacitors C60-C64 should be as close as possible to the PVDD and GND\_X pins, the heat sink sets the distance. Wide traces should be routed on the top layer with direct connection to the pins and without going through vias. No vias or traces should be blocking the current path.

**Note T2:** Close decoupling of PVDD with low impedance X7R ceramic capacitors is placed under the heat sink and close to the pins.

**Note T3:** Heat sink needs to have a good connection to PCB ground.

**Note T4:** Output filter capacitors must be linear in the applied voltage range preferable metal film types.

**Figure 14. Printed Circuit Board - Top Layer**

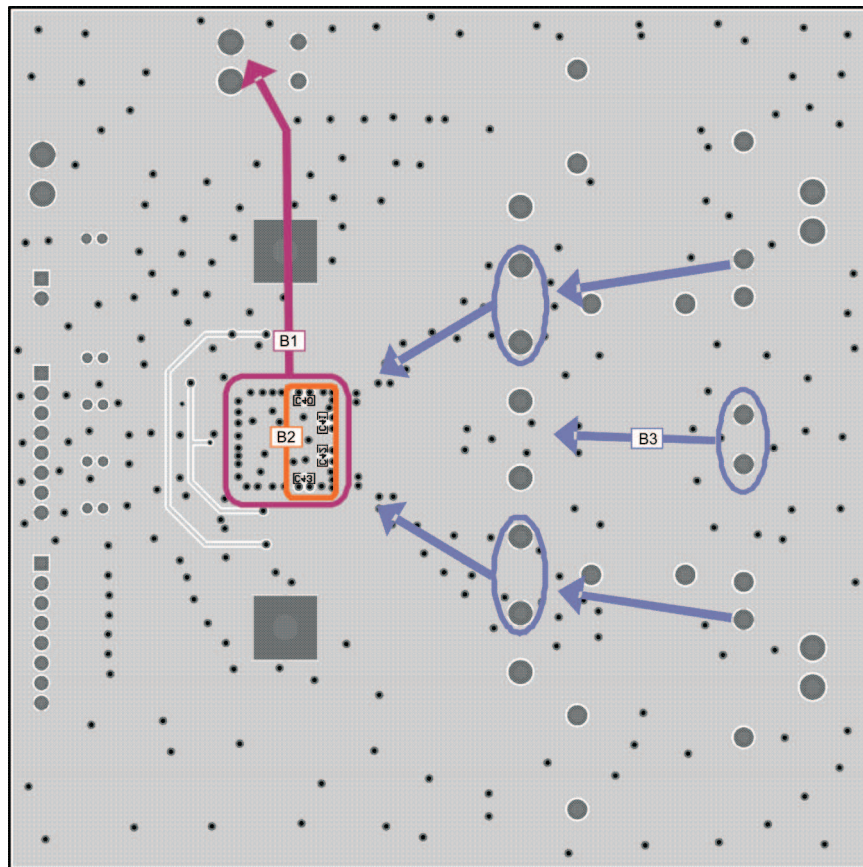

**Note B1:** It is important to have a direct low impedance return path for high current back to the power supply. Keep impedance low from top to bottom side of PCB through a lot of ground vias.

**Note B2:** Bootstrap low impedance X7R ceramic capacitors placed on bottom side providing a short low inductance current loop.

**Note B3:** Return currents from bulk capacitors and output filter capacitors.

**Figure 15. Printed Circuit Board – Bottom Layer**

## REVISION HISTORY

| Changes from Original (June 2010) to Revision A   | Page        |
|---|-------------|
| • Deleted the DKD 44-Pin package form the Features .....  | 1           |
| • Deleted DKD package drawing from the Pin Assignment section .....   | 2           |
| • Deleted the TAS5611ADKD from the PACKAGE HEAT DISSIPATION RATINGS table .....   | 3           |
| • Deleted the TAS5611ADKD from the ORDERING INFORMATION table .....   | 3           |
| • Changed the $F_{PWM\ MIN}$ and $R_{FREQ\_ADJ}$ values in the RECOMMENDED OPERATING CONDITIONS table .....                   | 4           |
| • Changed the $T_J$ Max value From: 150 To: 125 in the ROC table .....  | 4           |
| • Changed the $ V_{OS} $ values in the AUDIO CHARACTERISTICS (BTL) table From: TYP = 20, MAX = 40 To: TYP = 5, MAX = 18 ..... | 8           |
| • Changed the values fo the OSCILLATOR section of the ELECTRICAL CHARACTERISTICS TABLE .....                                  | 9           |
| • Deleted Figure 14. Typical Differential.....DKD Package drawing .....   | 14          |
| • Deleted the DKD Package text from the OVERTEMPERATURE PROTECTION section .....  | 19          |
| <br><b>Changes from Revision A (March 2011) to Revision B</b>   | <b>Page</b> |
| • Changed Voltage gain (G) TYP spec from "21" to "20" db db .....   | 9           |

**PACKAGING INFORMATION**

| Orderable Device | Status<br>(1) | Package Type | Package Drawing | Pins | Package Qty | Eco Plan<br>(2)         | Lead/Ball Finish | MSL Peak Temp<br>(3) | Op Temp (°C) | Top-Side Markings<br>(4) | Samples                 |
|------------------|---------------|--------------|-----------------|------|-------------|-------------------------|------------------|----------------------|--------------|--------------------------|-------------------------|
| TAS5611APHD      | ACTIVE        | HTQFP        | PHD             | 64   | 90          | Green (RoHS & no Sb/Br) | CU NIPDAU        | Level-3-260C-168 HR  | 0 to 70      | TAS5611A                 | <a href="#">Samples</a> |
| TAS5611APHDR     | ACTIVE        | HTQFP        | PHD             | 64   | 1000        | Green (RoHS & no Sb/Br) | CU NIPDAU        | Level-3-260C-168 HR  | 0 to 70      | TAS5611A                 | <a href="#">Samples</a> |

(1) The marketing status values are defined as follows:

**ACTIVE:** Product device recommended for new designs.

**LIFEBUY:** TI has announced that the device will be discontinued, and a lifetime-buy period is in effect.

**NRND:** Not recommended for new designs. Device is in production to support existing customers, but TI does not recommend using this part in a new design.

**PREVIEW:** Device has been announced but is not in production. Samples may or may not be available.

**OBSOLETE:** TI has discontinued the production of the device.

(2) Eco Plan - The planned eco-friendly classification: Pb-Free (RoHS), Pb-Free (RoHS Exempt), or Green (RoHS & no Sb/Br) - please check <http://www.ti.com/productcontent> for the latest availability information and additional product content details.

**TBD:** The Pb-Free/Green conversion plan has not been defined.

**Pb-Free (RoHS):** TI's terms "Lead-Free" or "Pb-Free" mean semiconductor products that are compatible with the current RoHS requirements for all 6 substances, including the requirement that lead not exceed 0.1% by weight in homogeneous materials. Where designed to be soldered at high temperatures, TI Pb-Free products are suitable for use in specified lead-free processes.

**Pb-Free (RoHS Exempt):** This component has a RoHS exemption for either 1) lead-based flip-chip solder bumps used between the die and package, or 2) lead-based die adhesive used between the die and leadframe. The component is otherwise considered Pb-Free (RoHS compatible) as defined above.

**Green (RoHS & no Sb/Br):** TI defines "Green" to mean Pb-Free (RoHS compatible), and free of Bromine (Br) and Antimony (Sb) based flame retardants (Br or Sb do not exceed 0.1% by weight in homogeneous material)

(3) MSL, Peak Temp. -- The Moisture Sensitivity Level rating according to the JEDEC industry standard classifications, and peak solder temperature.

(4) Multiple Top-Side Markings will be inside parentheses. Only one Top-Side Marking contained in parentheses and separated by a "~" will appear on a device. If a line is indented then it is a continuation of the previous line and the two combined represent the entire Top-Side Marking for that device.

**Important Information and Disclaimer:** The information provided on this page represents TI's knowledge and belief as of the date that it is provided. TI bases its knowledge and belief on information provided by third parties, and makes no representation or warranty as to the accuracy of such information. Efforts are underway to better integrate information from third parties. TI has taken and continues to take reasonable steps to provide representative and accurate information but may not have conducted destructive testing or chemical analysis on incoming materials and chemicals. TI and TI suppliers consider certain information to be proprietary, and thus CAS numbers and other limited information may not be available for release.

In no event shall TI's liability arising out of such information exceed the total purchase price of the TI part(s) at issue in this document sold by TI to Customer on an annual basis.

## TAPE AND REEL INFORMATION



### QUADRANT ASSIGNMENTS FOR PIN 1 ORIENTATION IN TAPE



\*All dimensions are nominal

| Device       | Package Type | Package Drawing | Pins | SPQ  | Reel Diameter (mm) | Reel Width W1 (mm) | A0 (mm) | B0 (mm) | K0 (mm) | P1 (mm) | W (mm) | Pin1 Quadrant |
|--------------|--------------|-----------------|------|------|--------------------|--------------------|---------|---------|---------|---------|--------|---------------|
| TAS5611APHDR | HTQFP        | PHD             | 64   | 1000 | 330.0              | 24.4               | 17.0    | 17.0    | 1.5     | 20.0    | 24.0   | Q2            |

**TAPE AND REEL BOX DIMENSIONS**



\*All dimensions are nominal

| Device       | Package Type | Package Drawing | Pins | SPQ  | Length (mm) | Width (mm) | Height (mm) |
|--------------|--------------|-----------------|------|------|-------------|------------|-------------|
| TAS5611APHDR | HTQFP        | PHD             | 64   | 1000 | 350.0       | 350.0      | 43.0        |

## GENERIC PACKAGE VIEW

**PHD 64**

**HTQFP - 1.20 mm max height**

14 x 14, 0.8 mm pitch

QUAD FLATPACK

This image is a representation of the package family, actual package may vary.  
Refer to the product data sheet for package details.

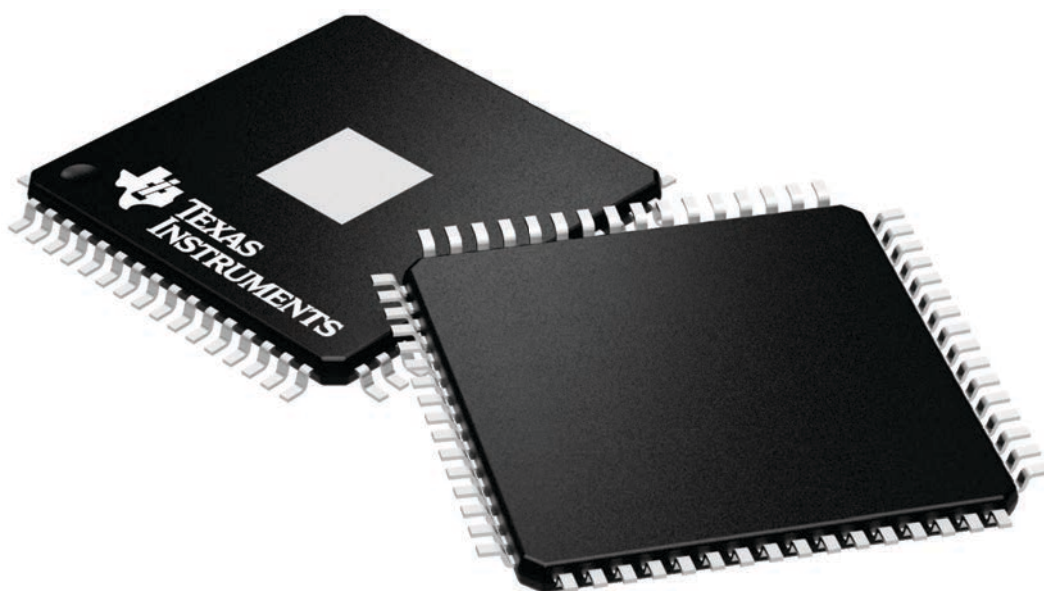

4224851/A



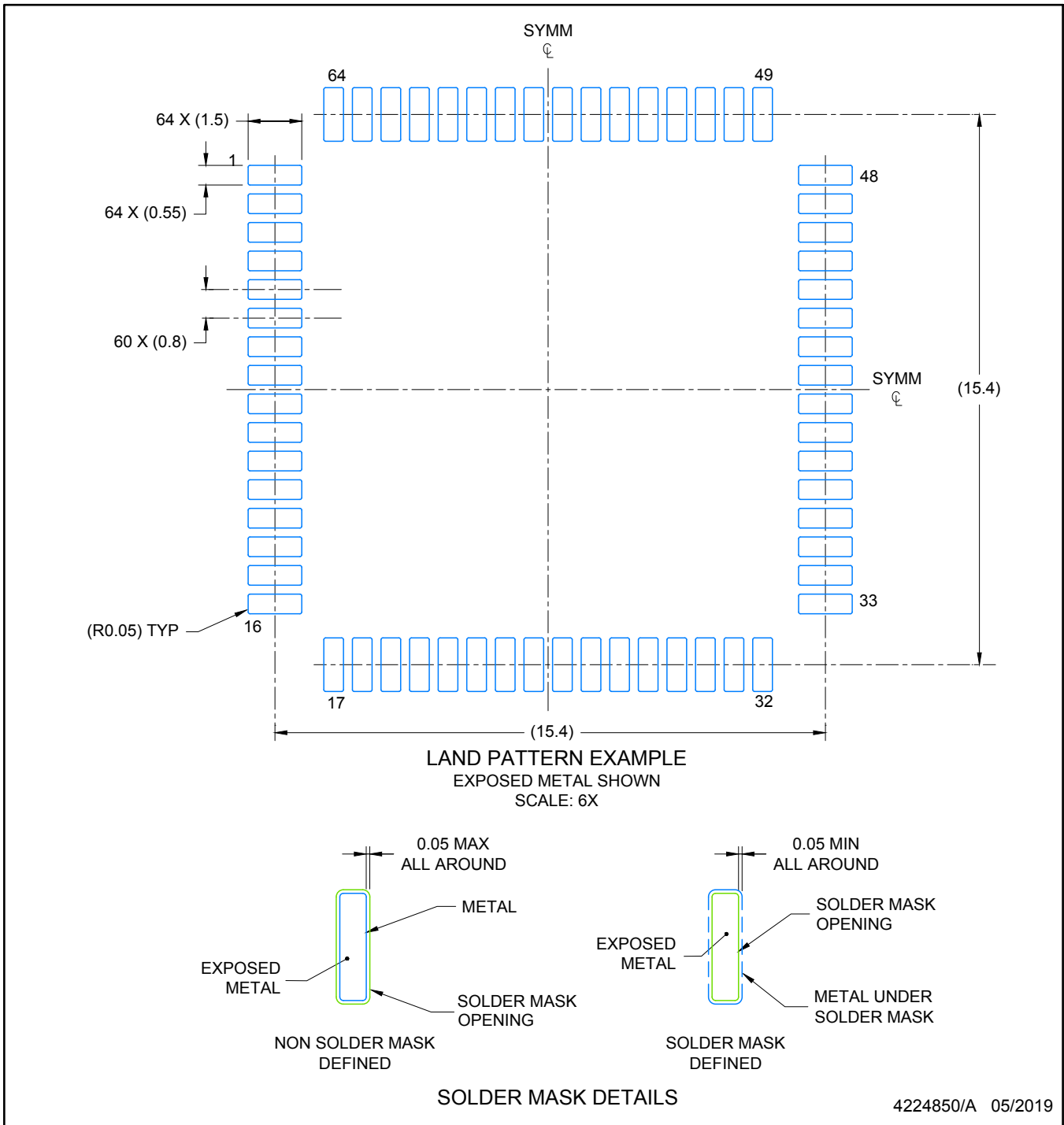

NOTES: (continued)

5. Publication IPC-7351 may have alternate designs.
6. Solder mask tolerances between and around signal pads can vary based on board fabrication site.
7. Vias are optional depending on application, refer to device data sheet. It is recommended that vias under paste be filled, plugged or tented.

# EXAMPLE STENCIL DESIGN

HTQFP - 1.2 mm max height

PHD0064B

PLASTIC QUAD FLATPACK

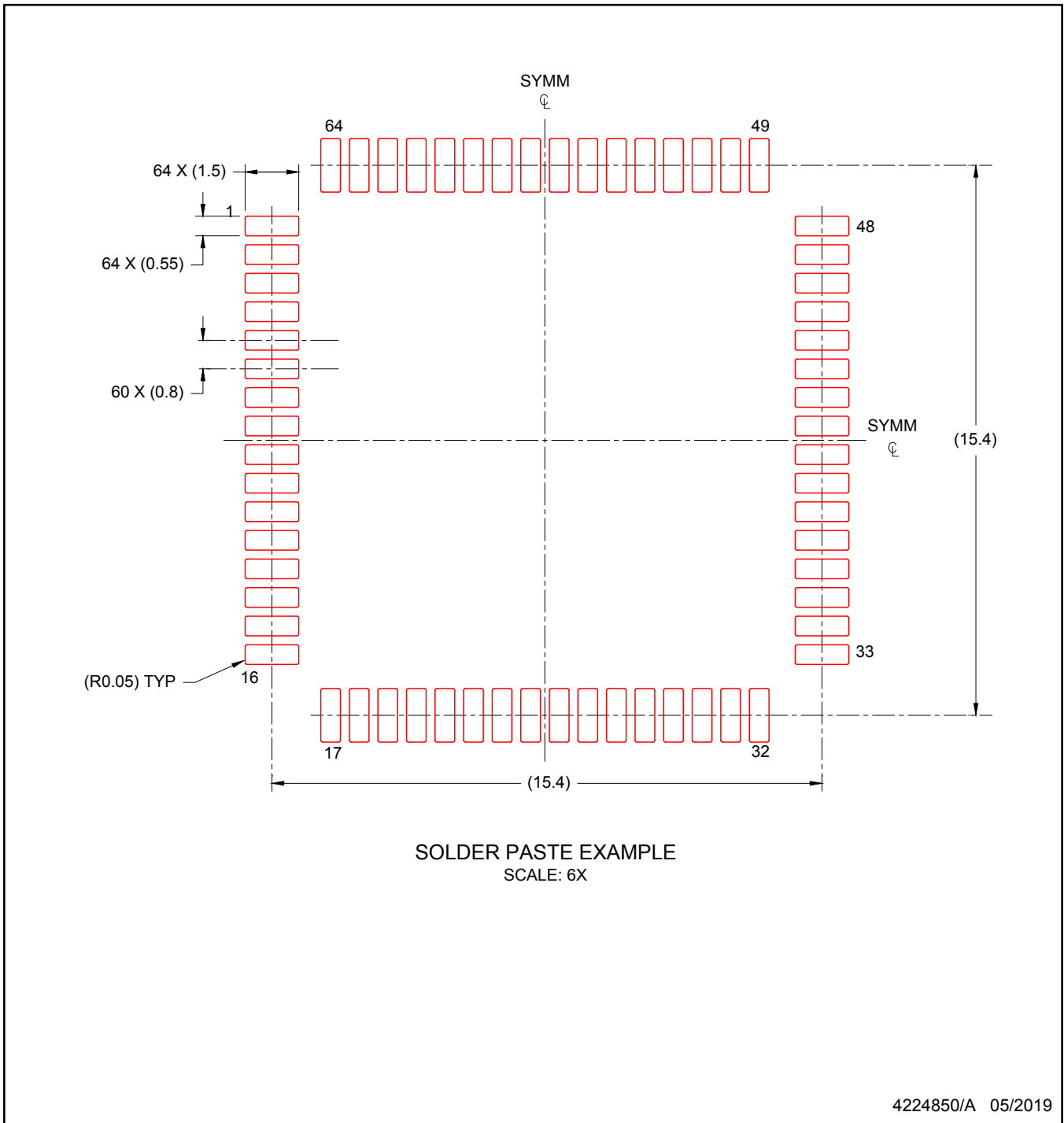

NOTES: (continued)

7. Laser cutting apertures with trapezoidal walls and rounded corners may offer better paste release. IPC-7525 may have alternate design recommendations.
8. Board assembly site may have different recommendations for stencil design.

## IMPORTANT NOTICE AND DISCLAIMER

TI PROVIDES TECHNICAL AND RELIABILITY DATA (INCLUDING DATASHEETS), DESIGN RESOURCES (INCLUDING REFERENCE DESIGNS), APPLICATION OR OTHER DESIGN ADVICE, WEB TOOLS, SAFETY INFORMATION, AND OTHER RESOURCES "AS IS" AND WITH ALL FAULTS, AND DISCLAIMS ALL WARRANTIES, EXPRESS AND IMPLIED, INCLUDING WITHOUT LIMITATION ANY IMPLIED WARRANTIES OF MERCHANTABILITY, FITNESS FOR A PARTICULAR PURPOSE OR NON-INFRINGEMENT OF THIRD PARTY INTELLECTUAL PROPERTY RIGHTS.

These resources are intended for skilled developers designing with TI products. You are solely responsible for (1) selecting the appropriate TI products for your application, (2) designing, validating and testing your application, and (3) ensuring your application meets applicable standards, and any other safety, security, or other requirements. These resources are subject to change without notice. TI grants you permission to use these resources only for development of an application that uses the TI products described in the resource. Other reproduction and display of these resources is prohibited. No license is granted to any other TI intellectual property right or to any third party intellectual property right. TI disclaims responsibility for, and you will fully indemnify TI and its representatives against, any claims, damages, costs, losses, and liabilities arising out of your use of these resources.

TI's products are provided subject to TI's Terms of Sale ([www.ti.com/legal/termsofsale.html](http://www.ti.com/legal/termsofsale.html)) or other applicable terms available either on [ti.com](http://ti.com) or provided in conjunction with such TI products. TI's provision of these resources does not expand or otherwise alter TI's applicable warranties or warranty disclaimers for TI products.

Mailing Address: Texas Instruments, Post Office Box 655303, Dallas, Texas 75265  
Copyright © 2019, Texas Instruments Incorporated

## Looking for pricing, stock, or lifecycle information?

Click below to explore more details on WIN SOURCE:

 [View TAS5611APHDR on WIN SOURCE](#)

 [Texas Instruments](#) Information

## Optimize Your Supply Chain with WIN SOURCE Solutions

-  Global Sourcing Solution
-  Obsolete Management
-  Cost Control Management
-  Shortage Management
-  Alternative Solution
-  Excess Inventory Management