



**THE DATASHEET OF
ATS-TI1OP-518-C1-R0**



Heat Sinks For Texas Instruments

ATS PART # ATS-TI10P-518-C1-R0

Features & Benefits

- » Optimized for natural convection air cooling
- » Black anodized for maximum heat dissipation
- » Designed specifically for TI's Module
#TAS5611 (#TAS5611PHD2EVM),
#TAS5613 (#TAS5613PHD2EVM)
- » Heat sinks come with two threaded mounting holes

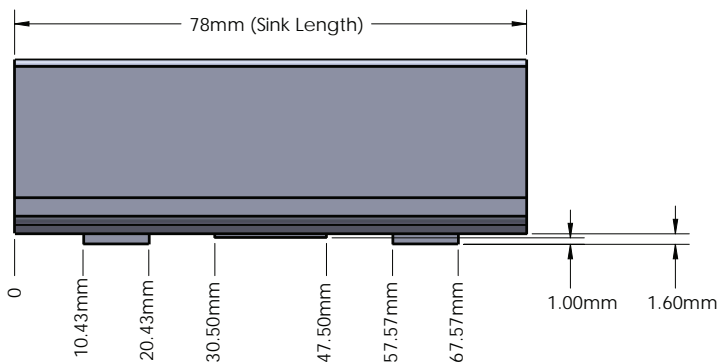
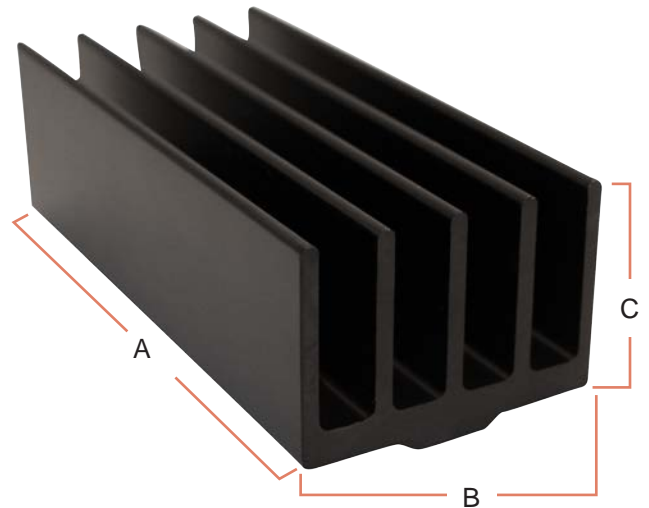

**Images are for illustration purposes only.*

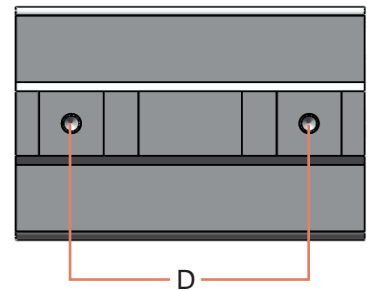

Thermal Performance

AIR VELOCITY		THERMAL RESISTANCE	
FT/MIN	M/S	°C/W (UNDUCTED FLOW)	°C/W (DUCTED FLOW)
200	1.0	3.0	2.0
300	1.5	2.5	n/a
400	2.0	2.2	n/a
500	2.5	2.0	n/a
600	3.0	1.8	n/a
700	3.5	1.7	n/a
800	4.0	1.6	n/a

Product Details

Dimension A	Dimension B	Dimension C	Dimension D	Thread Depth	Thread Type	Interface Material	Finish
78 mm	36 mm	28.1 mm	47.14 mm	6 mm	M3	N/A	Black Anodized

Notes:

- 1) Dimension A = heat sink length
- 2) Dimension B = heat sink width
- 3) Dimension C = heat sink height from bottom of the base to the top of the fin field (all in mm)
- 4) Dimension D = Hole distance center to center (mm)
- 5) Dimension E = Hole depth (mm)
- 6) Material AL-6063





ATS ADVANCED
THERMAL
SOLUTIONS, INC.
Innovations in Thermal Management®

For more information, to find a distributor or to place an order, visit www.qats.com or call: 781.769.2800.

Looking for pricing, stock, or lifecycle information?

Click below to explore more details on WIN SOURCE:

-  [View **ATS-TI1OP-518-C1-R0** on WIN SOURCE](#)
-  [Advanced Thermal Solutions Inc. Information](#)

Optimize Your Supply Chain with WIN SOURCE Solutions

-  Global Sourcing Solution
-  Obsolete Management
-  Cost Control Management
-  Shortage Management
-  Alternative Solution
-  Excess Inventory Management