



THE DATASHEET OF TAS5352ADDVR



TAS5352A 125-W Stereo Digital Amplifier Power Stage

1 Features

- Total Power Output (Bridge-Tied Load)
 - 2 × 125 W at 10% THD+N Into 4 Ω
 - 2 × 100 W at 10% THD+N Into 6 Ω
- Total Power Output (Single-Ended)
 - 4 × 45 W at 10% THD+N Into 3 Ω
 - 4 × 35 W at 10% THD+N Into 4 Ω
- Total Power Output (Parallel Mode)
 - 1 × 250 W at 10% THD+N Into 2 Ω
 - 1 × 195 W at 10% THD+N Into 3 Ω
- >110 dB SNR (A-Weighted With [TAS5518](#) Modulator)
- <0.1% THD+N (1 W, 1 kHz)
- Supports PWM Frame Rates of 192 kHz to 432 kHz
- Resistor-Programmable Current Limit
- Integrated Self-Protection Circuitry, Including:
 - Undervoltage Protection
 - Overtemperature Warning and Error
 - Overload Protection
 - Short-Circuit Protection
 - PWM Activity Detector
- Stand-Alone Protection Recovery
- Power-On-Reset (POR) to Eliminate System Power-Supply Sequencing
- High-Efficiency Power Stage (>90%) With 80-mΩ Output MOSFETs
- Thermally Enhanced 44-Pin HTSSOP Package (DDV)
- Error Reporting, 3.3-V and 5-V Compliant
- EMI Compliant When Used With Recommended System Design

2 Applications

- Mini and Micro Audio Systems
- DVD Receivers
- Home Theaters

3 Description

The TAS5352A device is a high-performance, integrated stereo digital amplifier power stage designed to drive a 4-Ω bridge-tied load (BTL) at up to 125 W per channel with low harmonic distortion, low integrated noise, and low idle current.

The TAS5352A has a complete protection system integrated on-chip, safeguarding the device against a wide range of fault conditions that could damage the system. These protection features are short-circuit protection, overcurrent protection, undervoltage protection, overtemperature protection, and a loss of PWM signal (PWM activity detector).

A power-on-reset (POR) circuit is used to eliminate power-supply sequencing that is required for most power-stage designs.

Device Information⁽¹⁾

PART NUMBER	PACKAGE	BODY SIZE (NOM)
TAS5352A	HTSSOP (44)	14.00 mm × 6.10 mm

(1) For all available packages, see the orderable addendum at the end of the data sheet.

BTL Output Power vs Supply Voltage

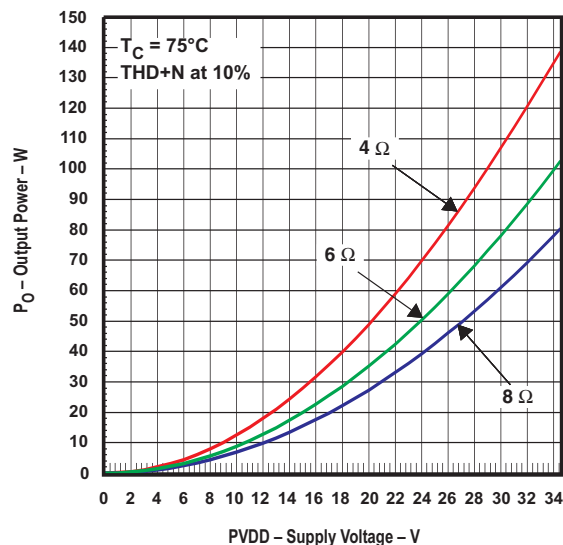

Table of Contents

1 Features	1	7.4 Device Functional Modes.....	17
2 Applications	1	8 Application and Implementation	18
3 Description	1	8.1 Application Information.....	18
4 Revision History	2	8.2 Typical Applications	18
5 Pin Configuration and Functions	3	8.3 System Example	24
6 Specifications	5	9 Power Supply Recommendations	25
6.1 Absolute Maximum Ratings	5	10 Layout	26
6.2 ESD Ratings.....	5	10.1 Layout Guidelines	26
6.3 Recommended Operating Conditions.....	5	10.2 Layout Example	27
6.4 Thermal Information	6	11 Device and Documentation Support	28
6.5 Electrical Characteristics.....	6	11.1 Device Support.....	28
6.6 Audio Specifications (BTL).....	7	11.2 Documentation Support	28
6.7 Audio Specifications (Single-Ended Output).....	8	11.3 Receiving Notification of Documentation Updates	28
6.8 Audio Specifications (PBTL)	8	11.4 Community Resources.....	28
6.9 Typical Characteristics.....	9	11.5 Trademarks	28
7 Detailed Description	12	11.6 Electrostatic Discharge Caution.....	28
7.1 Overview	12	11.7 Glossary	28
7.2 Functional Block Diagram	13	12 Mechanical, Packaging, and Orderable	28
7.3 Feature Description.....	14	Information	28

4 Revision History

NOTE: Page numbers for previous revisions may differ from page numbers in the current version.

Changes from Original (November 2008) to Revision A	Page
• Added <i>ESD Ratings</i> table, <i>Feature Description</i> section, <i>Device Functional Modes</i> , <i>Application and Implementation</i> section, <i>Power Supply Recommendations</i> section, <i>Layout</i> section, <i>Device and Documentation Support</i> section, and <i>Mechanical, Packaging, and Orderable Information</i> section	1
• Deleted <i>Ordering Information</i> table, see POA at the end of this data sheet.....	5
• Deleted <i>Package Heat Dissipation Ratings</i> table.....	5
• Updated values in the <i>Thermal Information</i> table to align with JEDEC standards	6

5 Pin Configuration and Functions

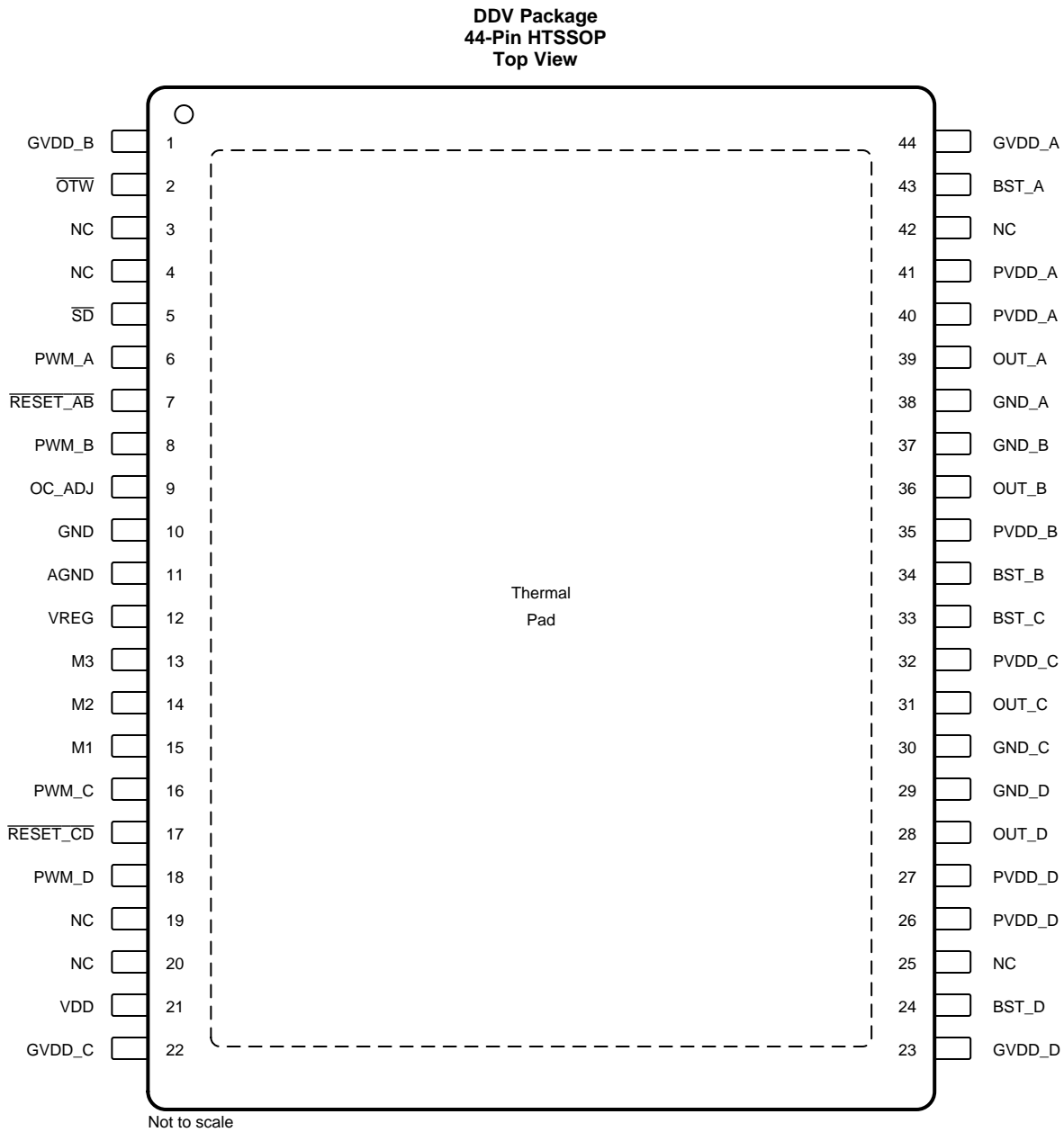

Pin Functions

PIN		TYPE ⁽¹⁾	DESCRIPTION
NAME	NO.		
AGND	11	P	Analog ground
BST_A	43	P	Bootstrap pin, A-Side
BST_B	34	P	Bootstrap pin, B-Side
BST_C	33	P	Bootstrap pin, C-Side
BST_D	24	P	Bootstrap pin, D-Side
GND	10	P	Ground
GND_A	38	P	Power ground for half-bridge A

(1) I = Input, O = Output, P = Power

Pin Functions (continued)

PIN		TYPE ⁽¹⁾	DESCRIPTION
NAME	NO.		
GND_B	37	P	Power ground for half-bridge B
GND_C	30	P	Power ground for half-bridge C
GND_D	29	P	Power ground for half-bridge D
GVDD_A	44	P	Gate-drive voltage supply; A-Side
GVDD_B	1	P	Gate-drive voltage supply; B-Side
GVDD_C	22	P	Gate-drive voltage supply; C-Side
GVDD_D	23	P	Gate-drive voltage supply; D-Side
M1	15	I	Mode selection pin (LSB)
M2	14	I	Mode selection pin
M3	13	I	Mode selection pin (MSB)
NC	3, 4, 19, 20, 25, 42	–	No connect. Pins may be grounded.
OC_ADJ	9	O	Analog overcurrent programming pin
\overline{OTW}	2	O	Overtemperature warning signal, open-drain, active-low
OUT_A	39	O	Output, half-bridge A
OUT_B	36	O	Output, half-bridge B
OUT_C	31	O	Output, half-bridge C
OUT_D	28	O	Output, half-bridge D
PVDD_A	40, 41	P	Power supply input for half-bridge A
PVDD_B	35	P	Power supply input for half-bridge B
PVDD_C	32	P	Power supply input for half-bridge C
PVDD_D	26, 27	P	Power supply input for half-bridge D
PWM_A	6	I	PWM Input signal for half-bridge A
PWM_B	8	I	PWM Input signal for half-bridge B
PWM_C	16	I	PWM Input signal for half-bridge C
PWM_D	18	I	PWM Input signal for half-bridge D
$\overline{RESET_AB}$	7	I	Reset signal for half-bridge A and half-bridge B, active-low
$\overline{RESET_CD}$	17	I	Reset signal for half-bridge C and half-bridge D, active-low
\overline{SD}	5	O	Shutdown signal, open-drain, active-low
VDD	21	P	Input power supply
VREG	12	P	Internal voltage regulator

6 Specifications

6.1 Absolute Maximum Ratings

over operating free-air temperature range (unless otherwise noted)⁽¹⁾

	MIN	MAX	UNIT
VDD to AGND	−0.3	13.2	V
GVDD_X to AGND	−0.3	13.2	V
PVDD_X to GND_X ⁽²⁾	−0.3	53	V
OUT_X to GND_X ⁽²⁾	−0.3	53	V
BST_X to GND_X ⁽²⁾	−0.3	66.2	V
BST_X to GVDD_X ⁽²⁾	−0.3	53	V
VREG to AGND	−0.3	4.2	V
GND_X to GND	−0.3	0.3	V
GND_X to AGND	−0.3	0.3	V
GND to AGND	−0.3	0.3	V
PWM_X, OC_ADJ, M1, M2, M3 to AGND	−0.3	4.2	V
RESET_X, SD, OTW to AGND	−0.3	7	V
Maximum continuous sink current (SD, OTW)		9	mA
Minimum pulse duration, low	30		ns
Lead temperature, 1.6 mm (1/16 inch) from case (10 s)		260	°C
Maximum operating junction temperature, T _J	0	125	°C
Storage temperature, T _{stg}	−40	125	°C

- (1) Stresses beyond those listed under *Absolute Maximum Ratings* may cause permanent damage to the device. These are stress ratings only, which do not imply functional operation of the device at these or any other conditions beyond those indicated under *Recommended Operating Conditions*. Exposure to absolute-maximum-rated conditions for extended periods may affect device reliability.
- (2) These voltages represent the DC voltage + peak AC waveform measured at the terminal of the device in all conditions.

6.2 ESD Ratings

		VALUE	UNIT
V _(ESD) Electrostatic discharge	Human-body model (HBM), per ANSI/ESDA/JEDEC JS-001 ⁽¹⁾	±2500	V
	Charged-device model (CDM), per JEDEC specification JESD22-C101 ⁽²⁾	±750	

- (1) JEDEC document JEP155 states that 500-V HBM allows safe manufacturing with a standard ESD control process.
- (2) JEDEC document JEP157 states that 250-V CDM allows safe manufacturing with a standard ESD control process.

6.3 Recommended Operating Conditions

		MIN	NOM	MAX	UNIT
PVDD_X	Half-bridge supply voltage	0	34.5	37	V
GVDD_X	Supply voltage for logic regulators and gate-drive circuitry	10.8	12	13.2	V
VDD	Digital regulator supply voltage	10.8	12	13.2	V
R _L (BTL)	Resistive load impedance (no cycle-by-cycle current control), recommended demodulation filter	3	4		Ω
R _L (SE)	Resistive load impedance (no cycle-by-cycle current control), recommended demodulation filter	2.25	3		
R _L (PBTL)	Resistive load impedance (no cycle-by-cycle current control), recommended demodulation filter	1.5	2		
L _{Output} (BTL)	Output-filter inductance, minimum output inductance under short-circuit condition	5	10		μH
L _{Output} (SE)	Output-filter inductance, minimum output inductance under short-circuit condition	5	10		
L _{Output} (PBTL)	Output-filter inductance, minimum output inductance under short-circuit condition	5	10		
f _S	PWM frame rate	192	384	432	kHz
t _{LOW}	Minimum low-state pulse duration per PWM Frame, noise shaper enabled	30			nS
C _{PVDD}	PVDD close decoupling capacitors		0.1		μF

Recommended Operating Conditions (continued)

		MIN	NOM	MAX	UNIT
C _{BST}	Bootstrap capacitor, selected value supports PWM frame rates from 192 kHz to 432 kHz		33		nF
R _{OC}	Overcurrent programming resistor, resistor tolerance = 5%	22	22	47	kΩ
R _{EXT-PULLUP}	External pullup resistor to 3.3 V to 5 V for \overline{SD} or \overline{OTW}	3.3	4.7		kΩ
T _J	Junction temperature	0		125	°C

6.4 Thermal Information

THERMAL METRIC ⁽¹⁾		TAS5352A			UNIT
		DDV (HTSSOP)			
		44 PINS			
R _{θJA}	Junction-to-ambient thermal resistance	41.1			°C/W
R _{θJC(top)}	Junction-to-case (top) thermal resistance	0.7			°C/W
R _{θJB}	Junction-to-board thermal resistance	18			°C/W
ψ _{JT}	Junction-to-top characterization parameter	0.7			°C/W
ψ _{JB}	Junction-to-board characterization parameter	17.9			°C/W
R _{θJC(bot)}	Junction-to-case (bottom) thermal resistance	n/a			°C/W

(1) For more information about traditional and new thermal metrics, see the [Semiconductor and IC Package Thermal Metrics](#) application report.

6.5 Electrical Characteristics

PVDD_x = 34.5 V, GVDD_x = 12 V, VDD = 12 V, T_C (Case temperature) = 25°C, and f_s = 384 kHz (unless otherwise noted).

PARAMETER		TEST CONDITIONS	MIN	TYP	MAX	UNIT
INTERNAL VOLTAGE REGULATOR AND CURRENT CONSUMPTION						
VREG	Voltage regulator (only used as a reference node)	VDD = 12 V	3	3.3	3.6	V
IVDD	VDD supply current	Operating, 50% duty cycle		7.2	17	mA
		Idle, reset mode		5.5	11	
IGVDD _x	Gate supply current per half-bridge	50% duty cycle		8	16	mA
		Reset mode		1	1.8	
IPVDD _x	Half-bridge idle current	50% duty cycle with 10-μH and 470-nF output filter		19	25	mA
		Reset mode, no switching		525	630	
OUTPUT STAGE MOSFETS						
R _{DSon,LS}	Drain-to-source resistance, low-side	T _J = 25°C, excludes metalization resistance		80	89	mΩ
R _{DSon,HS}	Drain-to-source resistance, high-side	T _J = 25°C, excludes metalization resistance		80	89	mΩ
I/O PROTECTION						
V _{uvp,G}	Undervoltage protection limit			9.5		V
V _{uvp,hyst} ⁽¹⁾	Undervoltage protection limit			250		mV
BST _{uvpF}	Puts device into RESET when BST voltage falls below limit			5.9		V
BST _{uvpR}	Brings device out of RESET when BST voltage rises above limit			7		V
OTW ⁽¹⁾	Overtemperature warning		115	125	135	°C
OTW _{HYST} ⁽¹⁾	Temperature drop needed below OTW temp. for OTW to be inactive after the OTW event			25		°C
OTE ⁽¹⁾	Overtemperature error threshold		145	155	165	°C

(1) Specified by design

Electrical Characteristics (continued)

PVDD_x = 34.5 V, GVDD_x = 12 V, VDD = 12 V, T_C (Case temperature) = 25°C, and f_S = 384 kHz (unless otherwise noted).

PARAMETER		TEST CONDITIONS	MIN	TYP	MAX	UNIT
OTE-OTW _{differential} ⁽¹⁾	$\overline{OTE} - \overline{OTW}$ differential	Temperature delta between \overline{OTW} and \overline{OTE}		30		°C
OLPC	Overload protection counter	f _S = 384 kHz		1.25		ms
I _{OC}	Overcurrent limit protection	Resistor—programmable, high-end, R _{OC} = 22 kΩ with 1-mS pulse		10.9		A
I _{OCT}	Overcurrent response time			150		ns
t _{ACTIVITY DETECTOR}	Time for PWM activity detector to activate when no PWM is present	Lack of transition of any PWM input		13.2		μS
I _{PD}	Output pulldown current of each half-bridge	Connected when \overline{RESET} is active to provide bootstrap capacitor charge. Not used in SE mode.		3		mA
STATIC DIGITAL SPECIFICATIONS						
V _{IH}	High-level input voltage	PWM_A, PWM_B, PWM_C, PWM_D, M1, M2, M3, RESET_AB, RESET_CD	2			V
V _{IL}	Low-level input voltage				0.8	V
I _{Leakage}	Input leakage current				100	μA
OTW/SHUTDOWN (SD)						
R _{INT_PU}	Internal pullup resistance, \overline{OTW} to VREG, \overline{SD} to VREG		20	26	32	kΩ
V _{OH}	High-level output voltage	Internal pullup resistor	3	3.3	3.6	V
		External pullup of 4.7 kΩ to 5 V	4.5		5	
V _{OL}	Low-level output voltage	I _O = 4 mA		0.2	0.4	V
FANOUT	Device fanout \overline{OTW} , \overline{SD}	No external pullup		30		Devices

6.6 Audio Specifications (BTL)

Audio performance is recorded as a chipset consisting of a [TAS5518](#) PWM processor (modulation index limited to 97.7%) and a TAS5352A power stage. PCB and system configuration are in accordance with recommended guidelines. Audio frequency = 1 kHz, PVDD_x = 34.5 V, GVDD_x = 12 V, R_L = 4 Ω, f_S = 384 kHz, R_{OC} = 22 kΩ, T_C = 75°C, output filter: L_{DEM} = 10 μH, C_{DEM} = 470 nF (unless otherwise noted).

PARAMETER		TEST CONDITIONS	MIN	TYP	MAX	UNIT
P _{OMAX}	Maximum power output	R _L = 4 Ω, 10% THD+N, clipped input signal		125		W
		R _L = 6 Ω, 10% THD+N, clipped input signal		100		
		R _L = 8 Ω, 10% THD+N, clipped input signal		76		
P _O	Unclipped power output	R _L = 4 Ω, 0 dBFS, unclipped input signal		96		
		R _L = 6 Ω, 0 dBFS, unclipped input signal		72		
		R _L = 8 Ω, 0 dBFS, unclipped input signal		57		
THD+N	Total harmonic distortion + noise	0 dBFS, AES17 filter		0.4%		
		1 W, AES17 filter		0.09%		
V _n	Output integrated noise	A-weighted, AES17 filter, Auto mute disabled		50		μV
SNR	Signal-to-noise ratio ⁽¹⁾	A-weighted, AES17 filter, Auto mute disabled		110		dB
DNR	Dynamic range	A-weighted, input level = -60 dBFS, AES17 filter		110		dB
DC Offset	Output offset voltage			±15		mV
P _{idle}	Power dissipation due to idle losses (IPVDD _x)	P _O = 0 W, all half-bridges switching ⁽²⁾		2.6		W

(1) SNR is calculated relative to 0-dBFS input level.

(2) Actual system idle losses are affected by core losses of output inductors.

6.7 Audio Specifications (Single-Ended Output)

Audio performance is recorded as a chipset consisting of a [TAS5086](#) PWM processor (modulation index limited to 97.7%) and a TAS5352A power stage. PCB and system configuration are in accordance with recommended guidelines. Audio frequency = 1 kHz, PVDD_x = 34.5 V, GVDD_x = 12 V, R_L = 4 Ω, f_S = 384 kHz, R_{OC} = 22 kΩ, T_C = 75°C, output filter: L_{DEM} = 20 μH, C_{DEM} = 1 μF (unless otherwise noted).

PARAMETER		TEST CONDITIONS	MIN	TYP	MAX	UNIT
P _{OMAX}	Maximum power output	R _L = 3 Ω, 10% THD+N, clipped input signal		45		W
		R _L = 4 Ω, 10% THD+N, clipped input signal		35		
P _O	Unclipped power output	R _L = 3 Ω, 0 dBFS, unclipped input signal		35		
		R _L = 4 Ω, 0 dBFS, unclipped input signal		25		
THD+N	Total harmonic distortion + noise	0 dBFS, AES17 filter		0.4%		
		1 W, AES17 filter		0.09%		
V _n	Output integrated noise	A-weighted, AES17 filter, Auto mute disabled		40		μV
SNR	Signal-to-noise ratio ⁽¹⁾	A-weighted, AES17 filter, Auto mute disabled		109		dB
DNR	Dynamic range	A-weighted, input level = -60 dBFS, AES17 filter		109		dB
P _{idle}	Power dissipation due to idle losses (IPVDD _X)	P _O = 0 W, all half-bridges switching ⁽²⁾		2.6		W

(1) SNR is calculated relative to 0-dBFS input level.

(2) Actual system idle losses are affected by core losses of output inductors.

6.8 Audio Specifications (PBTL)

Audio performance is recorded as a chipset consisting of a [TAS5518](#) PWM processor (modulation index limited to 97.7%) and a TAS5352A power stage. PCB and system configuration are in accordance with recommended guidelines. Audio frequency = 1 kHz, PVDD_x = 34.5 V, GVDD_x = 12 V, R_L = 3 Ω, f_S = 384 kHz, R_{OC} = 22 kΩ, T_C = 75°C, output filter: L_{DEM} = 10 μH, C_{DEM} = 1 μF (unless otherwise noted).

PARAMETER		TEST CONDITIONS	MIN	TYP	MAX	UNIT
P _{OMAX}	Maximum power output	R _L = 3 Ω, 10% THD+N, clipped input signal		195		W
		R _L = 2 Ω, 10% THD+N, clipped input signal		250		
P _O	Unclipped power output	R _L = 3 Ω, 0 dBFS, unclipped input signal		145		
		R _L = 2 Ω, 0 dBFS, unclipped input signal		190		
THD+N	Total harmonic distortion + noise	0 dBFS, AES17 filter		0.4%		
		1 W, AES17 filter		0.09%		
V _n	Output integrated noise	A-weighted, AES17 filter, Auto mute disabled		50		μV
SNR	Signal-to-noise ratio ⁽¹⁾	A-weighted, AES17 filter, Auto mute disabled		110		dB
DNR	Dynamic range	A-weighted, input level = -60 dBFS AES17 filter		110		dB
DC Offset	Output offset voltage			±15		mV
P _{idle}	Power dissipation due to idle losses (IPVDD _X)	P _O = 0 W, all half-bridges switching ⁽²⁾		2.6		W

(1) SNR is calculated relative to 0-dBFS input level.

(2) Actual system idle losses are affected by core losses of output inductors.

6.9 Typical Characteristics

6.9.1 BTL Configuration

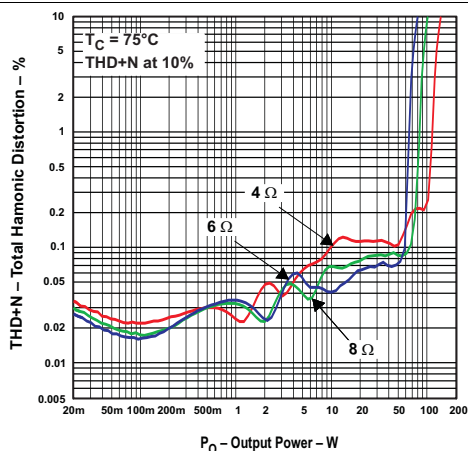

Figure 1. Total Harmonic Distortion + Noise vs Output Power

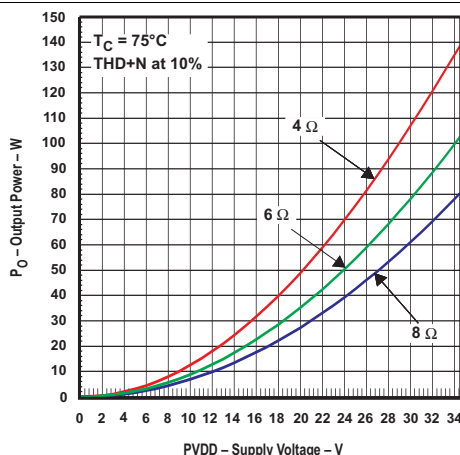

Figure 2. Output Power vs Supply Voltage

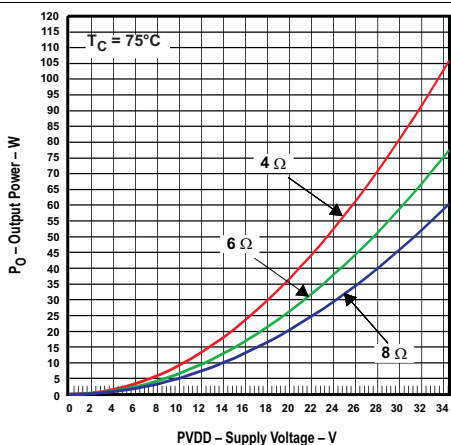

Figure 3. Unclipped Output Power vs Supply Voltage

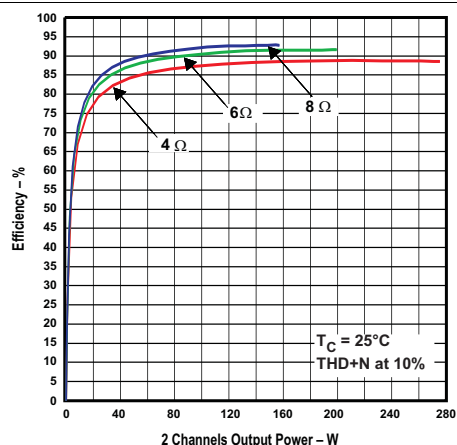

Figure 4. System Efficiency vs Output Power

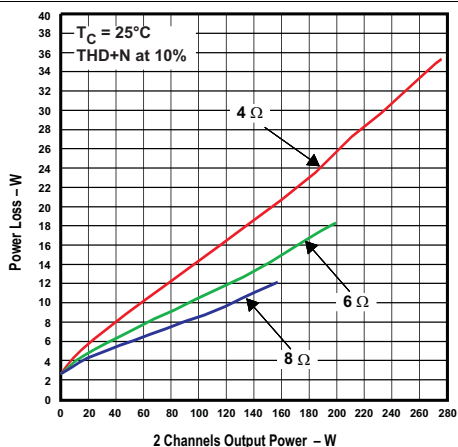

Figure 5. System Power Loss vs Output Power

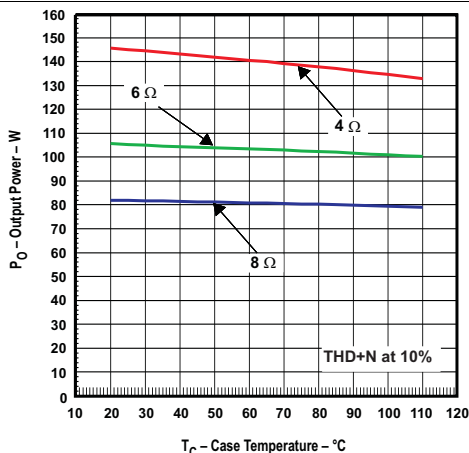

Figure 6. System Output Power vs Case Temperature

BTL Configuration (continued)

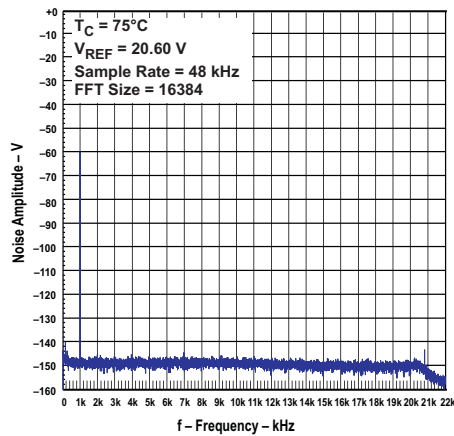

Figure 7. Noise Amplitude vs Frequency

6.9.2 SE Configuration

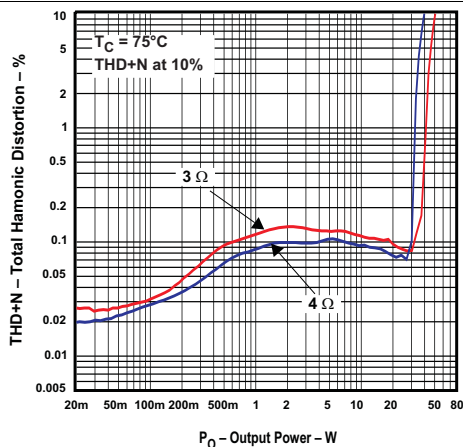

Figure 8. Total Harmonic Distortion + Noise vs Output Power

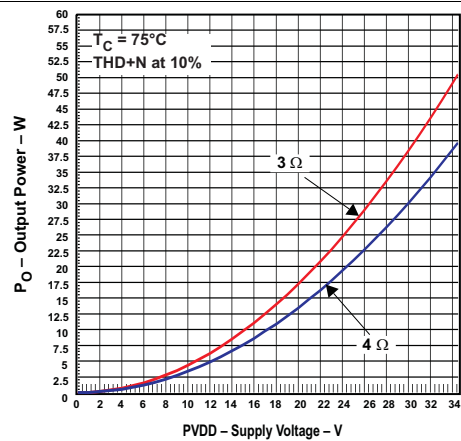

Figure 9. Output Power vs Supply Voltage

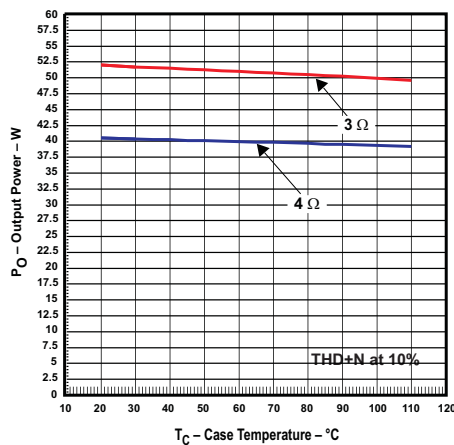

Figure 10. Output Power vs Case Temperature

6.9.3 PBTL Configuration

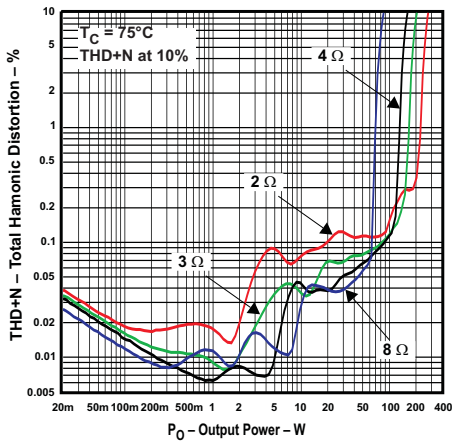

Figure 11. Total Harmonic Distortion + Noise vs Output Power

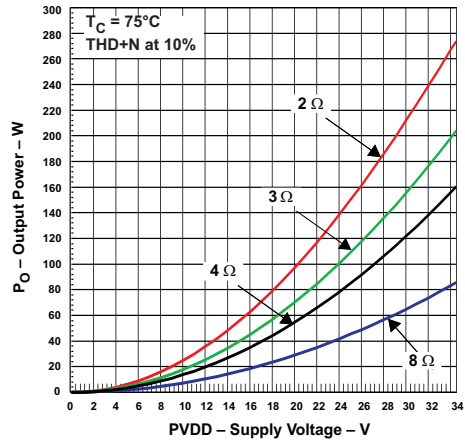

Figure 12. Output Power vs Supply Voltage

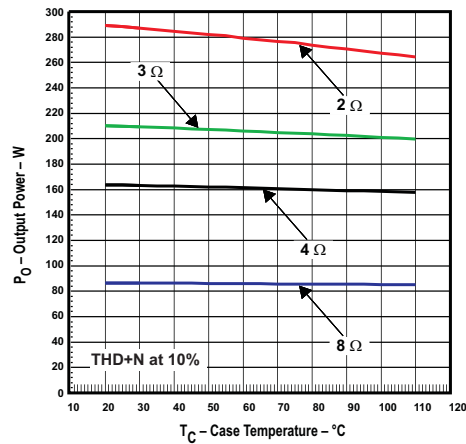

Figure 13. System Output Power vs Case Temperature

7 Detailed Description

7.1 Overview

The TAS5352A is a PWM input, Class-D audio amplifier. The output of the TAS5352A can be configured for single-ended, bridge-tied load (BTL), or parallel BTL (PBTL) output. The independent supply rails provide improved audio performance: one for audio power output (PVDD) and the other for gate drive and analog control (GVDD and VDD).

The TAS5352A contains a protection system that safeguards the device against short circuits, overload, overtemperature, and undervoltage conditions. An error reporting system provides feedback under fault conditions.

[Figure 14](#) shows typical connections for BTL outputs. A detailed schematic can be viewed in [TAS5352A EVM User's Guide](#) (SLAU244).

7.2 Functional Block Diagram

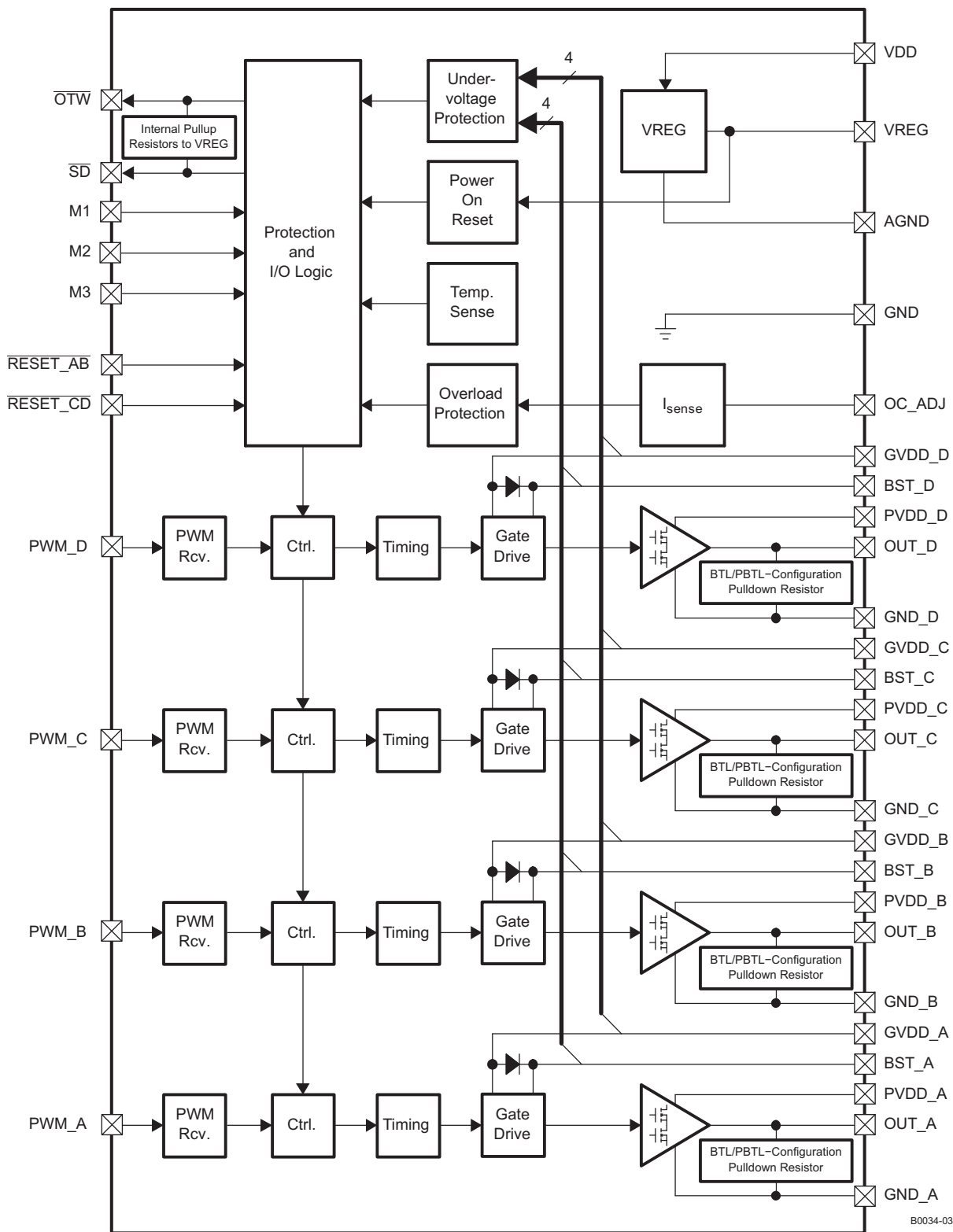

Copyright © 2016, Texas Instruments Incorporated

7.3 Feature Description

7.3.1 System Power-Up and Power-Down Sequence

7.3.1.1 Powering Up

The TAS5352A does not require a power-up sequence. The outputs of the H-bridges remain in a high-impedance state until the gate-drive supply voltage (GVDD_X) and VDD voltage are above the undervoltage protection (UVP) voltage threshold (see the [Electrical Characteristics](#)). Although not specifically required, TI recommends holding RESET_AB and RESET_CD in a low state while powering up the device. This allows an internal circuit to charge the external bootstrap capacitors by enabling a weak pulldown of the half-bridge output.

When the TAS5352A is being used with TI PWM modulators such as the [TAS5518](#), no special attention to the state of RESET_AB and RESET_CD is required, provided that the chipset is configured as recommended.

7.3.1.2 Powering Down

The TAS5352A does not require a power-down sequence. The device remains fully operational as long as the gate-drive supply (GVDD_X) voltage and VDD voltage are above the undervoltage protection (UVP) voltage threshold (see the [Electrical Characteristics](#)). Although not specifically required, it is a good practice to hold RESET_AB and RESET_CD low during power down, thus preventing audible artifacts including pops or clicks.

When the TAS5352A is being used with TI PWM modulators such as the [TAS5518](#), no special attention to the state of RESET_AB and RESET_CD is required, provided that the chipset is configured as recommended.

7.3.2 Mid Z Sequence Compatibility

The TAS5352A is compatible with the Mid Z Sequence of the [TAS5086](#) modulator. The Mid Z Sequence is a series of pulses that is generated by the modulator. This sequence causes the power stage to slowly enable its outputs as it begins to switch.

By slowly starting the PWM switching, the impulse response created by the onset of switching is reduced. This impulse response is the acoustic artifact that is heard in the output transducers (loudspeakers) and is commonly termed *click* or *pop*.

The low acoustic artifact noise of the TAS5352A will be further decreased when used in conjunction with the [TAS5086](#) modulator with the Mid Z Sequence enabled.

The Mid Z Sequence is primarily used for the single-ended output configuration. It facilitates a *softer* PWM output start after the split cap output configuration is charged.

7.3.3 Error Reporting

The \overline{SD} and \overline{OTW} pins are both active-low, open-drain outputs. Their function is for protection-mode signaling to a PWM controller or other system-control device.

Any fault resulting in device shutdown is signaled by the \overline{SD} pin going low. Likewise, \overline{OTW} goes low when the device junction temperature exceeds 125°C (see [Table 1](#)).

Table 1. Error Reporting

\overline{SD}	\overline{OTW}	DESCRIPTION
0	0	Overtemperature (OTE) or overload (OLP) or undervoltage (UVP)
0	1	Overload (OLP) or undervoltage (UVP)
1	0	Junction temperature higher than 125°C (overtemperature warning)
1	1	Junction temperature lower than 125°C and no OLP or UVP faults (normal operation)

Note that asserting either $\overline{RESET_AB}$ or $\overline{RESET_CD}$ low forces the \overline{SD} signal high, independent of faults being present. TI recommends monitoring the \overline{OTW} signal using the system microcontroller and responding to an overtemperature warning signal by, for example, turning down the volume to prevent further heating of the device resulting in device shutdown (OTE).

To reduce external component count, an internal pullup resistor to 3.3 V is provided on both \overline{SD} and \overline{OTW} outputs. Level compliance for 5-V logic can be obtained by adding external pullup resistors to 5 V (see the [Electrical Characteristics](#) table for further specifications).

7.3.4 Device Protection System

The TAS5352A contains advanced protection circuitry carefully designed to facilitate system integration and ease of use, as well as to safeguard the device from permanent failure due to a wide range of fault conditions such as short circuits, overload, overtemperature, and undervoltage. The TAS5352A responds to a fault by immediately setting the power stage in a high-impedance (Hi-Z) state and asserting the \overline{SD} pin low. In situations other than overload and overtemperature error (\overline{OTE}), the device automatically recovers when the fault condition has been removed, that is, the supply voltage has increased.

The device will function on errors, as shown in [Table 2](#).

Table 2. Device Protection

BTL MODE		PBTL MODE		SE MODE	
LOCAL ERROR IN	TURNS OFF	LOCAL ERROR IN	TURNS OFF	LOCAL ERROR IN	TURNS OFF
A	A + B	A	A + B + C + D	A	A + B
B		B		B	
C	C + D	C		C	C + D
D		D		D	

Bootstrap UVP does not shutdown according to [Table 2](#), it shuts down the respective half-bridge.

7.3.4.1 Use of TAS5352A in High-Modulation-Index Capable Systems

This device requires at least 30 ns of low time on the output per 384-kHz PWM frame rate to keep the bootstrap capacitors charged. As an example, if the modulation index is set to 99.2% in the [TAS5508](#), this setting allows PWM pulse durations down to 10 ns. This signal, which does not meet the 30-ns requirement, is sent to the PWM_X pin and this low-state pulse time does not allow the bootstrap capacitor to stay charged. The TAS5352A device requires limiting the [TAS5508](#) modulation index to 97.7% to keep the bootstrap capacitor charged under all signals and loads.

The TAS5352A contains a bootstrap capacitor undervoltage protection circuit (BST_UVP) that monitors the voltage on the bootstrap capacitors. When the voltage on the bootstrap capacitors is less than required for proper control of the high-side MOSFETs, the device initiates the bootstrap capacitor recharge sequences until the bootstrap capacitors are properly charged for robust operation. This function may be activated with PWM pulses less than 30 ns.

Therefore, TI strongly recommends using a TI PWM processor, such as [TAS5518](#), [TAS5086](#), or [TAS5508](#), with the modulation index set at 97.7% to interface with TAS5352A.

7.3.4.2 Overcurrent (OC) Protection With Current Limiting and Overload Detection

The device has independent, fast-reacting current detectors with programmable trip threshold (OC threshold) on all high-side and low-side power-stage FETs. See [Table 3](#) for OC-adjust resistor values. The detector outputs are closely monitored by two protection systems. The first protection system controls the power stage to prevent the output current from further increasing, that is, it performs a current-limiting function rather than prematurely shutting down during combinations of high-level music transients and extreme speaker load impedance drops. If the high-current situation persists, that is, the power stage is being overloaded, a second protection system triggers a latching shutdown, resulting in the power stage being set in the high-impedance (Hi-Z) state. Current limiting and overload protection are independent for half-bridges A and B and, respectively, C and D. That is, if the bridge-tied load between half-bridges A and B causes an overload fault, only half-bridges A and B are shut down.

- For the lowest-cost bill of materials in terms of component selection, the OC threshold measure should be limited, considering the power output requirement and minimum load impedance. Higher-impedance loads require a lower OC threshold.
- The demodulation-filter inductor must retain at least 5 μ H of inductance at twice the OC threshold setting.

Unfortunately, most inductors have decreasing inductance with increasing temperature and increasing current (saturation). To some degree, an increase in temperature naturally occurs when operating at high output currents, due to core losses and the DC resistance of the copper winding of the inductor. A thorough analysis of inductor saturation and thermal properties is strongly recommended.

Setting the OC threshold too low might cause issues such as lack of enough output power or unexpected shutdowns due to too-sensitive overload detection.

In general, TI recommends following the external component selection and PCB layout in the [Detailed Design Procedure](#) closely.

For added flexibility, the OC threshold is programmable within a limited range using a single external resistor connected between the OC_ADJ pin and AGND. See the [Electrical Characteristics](#) table for information on the correlation between programming-resistor value and the OC threshold.

NOTE

A properly functioning overcurrent detector assumes the presence of a properly designed demodulation filter at the power-stage output. It is required to follow the guidelines in [Table 3](#) when selecting the OC threshold and an appropriate demodulation inductor.

Table 3. Overcurrent Resistor Selection

OC-ADJUST RESISTOR VALUES (k Ω)	MAX CURRENT BEFORE OC OCCURS (A), T _c = 75°C
22	10.9
33	9.1
47	7.1

The reported maximum peak current in the table above is measured with continuous current in 1 Ω , one channel active and the other one muted.

7.3.4.3 Pin-to-Pin Short-Circuit Protection (PPSC)

The PPSC detection system protects the device from permanent damage in the case that a power output pin (OUT_X) is shorted to GND_X or PVDD_X. For comparison the OC protection system detects an over current after the demodulation filter where PPSC detects shorts directly at the pin before the filter. PPSC detection is performed at start-up, that is, when VDD is supplied, consequently a short to either GND_X or PVDD_X after system start-up does not activate the PPSC detection system. When PPSC detection is activated by a short on the output, all half-bridges are kept in a Hi-Z state until the short is removed, the device then continues the start-up sequence and starts switching. The detection is controlled globally by a two-step sequence. The first step ensures that there are no shorts from OUT_X to GND_X, the second step tests that there are no shorts from OUT_X to PVDD_X. The total duration of this process is roughly proportional to the capacitance of the output LC filter. The typical duration is < 15 ms/ μ F. While the PPSC detection is in progress, \overline{SD} is kept low and the device does not react to changes applied to the \overline{RESET} pins. If no shorts are present the PPSC detection passes, and \overline{SD} is released. A device reset will not start a new PPSC detection. PPSC detection is enabled in BTL and PBTL output configurations, the detection is not performed in SE mode. To make sure not to trip the PPSC detection system, TI recommends not to insert any resistive load to GND_X or PVDD_X.

7.3.4.4 Overtemperature Protection

The TAS5352A has a two-level temperature-protection system that asserts an active-low warning signal (\overline{OTW}) when the device junction temperature exceeds 125°C (typical) and, if the device junction temperature exceeds 155°C (typical), the device is put into thermal shutdown, resulting in all half-bridge outputs being set in the high-impedance (Hi-Z) state and \overline{SD} being asserted low. OTE is latched in this case. To clear the OTE latch, either $\overline{RESET_AB}$ or $\overline{RESET_CD}$ must be asserted. Thereafter, the device resumes normal operation.

7.3.4.5 Undervoltage Protection (UVP) and Power-On-Reset (POR)

The UVP and POR circuits of the TAS5352A fully protect the device in any power up, power down, or brownout situations. While powering up, the POR circuit resets the overload circuit (OLP) and ensures that all circuits are fully operational when the GVDD_X and VDD supply voltages reach stated in the [Electrical Characteristics](#). Although GVDD_X and VDD are independently monitored, a supply voltage drop below the UVP threshold on any VDD or GVDD_X pin results in all half-bridge outputs immediately being set in the high-impedance (Hi-Z) state and \overline{SD} being asserted low. The device automatically resumes operation when all supply voltages have increased above the UVP threshold.

7.3.5 Device Reset

Two reset pins are provided for independent control of half-bridges A/B and C/D. When $\overline{\text{RESET_AB}}$ is asserted low, all four power-stage FETs in half-bridges A and B are forced into a high-impedance (Hi-Z) state. Likewise, asserting $\overline{\text{RESET_CD}}$ low forces all four power-stage FETs in half-bridges C and D into a high-impedance state. Thus, both reset pins are well suited for hard-muting the power stage, if needed.

In BTL modes, to accommodate bootstrap charging prior to switching start, asserting the reset inputs low enables weak pulldown of the half-bridge outputs. In the SE mode, the weak pulldowns are not enabled. Therefore, TI recommends ensuring bootstrap capacitor charging by providing a low pulse on the PWM inputs when reset is asserted high.

Asserting either reset input low removes any fault information to be signaled on the $\overline{\text{SD}}$ output, that is, $\overline{\text{SD}}$ is forced high.

A rising-edge transition on either reset input allows the device to resume operation after an overload fault. To ensure thermal reliability, the rising edge of reset must occur no sooner than 4 ms after the falling edge of $\overline{\text{SD}}$.

7.4 Device Functional Modes

7.4.1 Protection MODE Selection Pins

Protection modes are selected by shorting M1, M2, and M3 to VREG or GND.

Table 4. Protection Mode Selection Pins

MODE PINS			MODE NAME	PWM INPUT ⁽¹⁾	DESCRIPTION
M3	M2	M1			
0	0	0	BTL mode 1	2N	All protection systems enabled
0	0	1	BTL mode 2	2N	Latching shutdown on, PWM activity detector and OLP disabled
0	1	0	BTL mode 3	1N	All protection systems enabled
0	1	1	PBTL mode	1N / 2N ⁽²⁾	All protection systems enabled
1	0	0	SE mode 1	1N	All protection systems enabled ⁽³⁾
1	0	1	SE mode 2	1N	Latching shutdown on, PWM activity detector and OLP disabled ⁽³⁾
1	1	0	Reserved		
1	1	1			

(1) The 1N and 2N naming convention is used to indicate the number of PWM lines to the power stage per channel in a specific mode.

(2) PWM_D is used to select between the 1N and 2N interface in PBTL mode (Low = 1N; High = 2N). PWM_D is internally pulled low in PBTL mode. PWM_A is used as the PWM input in 1N mode and PWM_A and PWM_B are used as inputs for the 2N mode.

(3) PPSC detection system disabled.

8 Application and Implementation

NOTE

Information in the following applications sections is not part of the TI component specification, and TI does not warrant its accuracy or completeness. TI's customers are responsible for determining suitability of components for their purposes. Customers should validate and test their design implementation to confirm system functionality.

8.1 Application Information

The TAS5352A can be configured either in stereo BTL mode, 4 channel SE mode, or mono PBTL mode, depending on output power conditions and system design.

8.2 Typical Applications

8.2.1 BTL Application With AD Modulation Filters – 2N

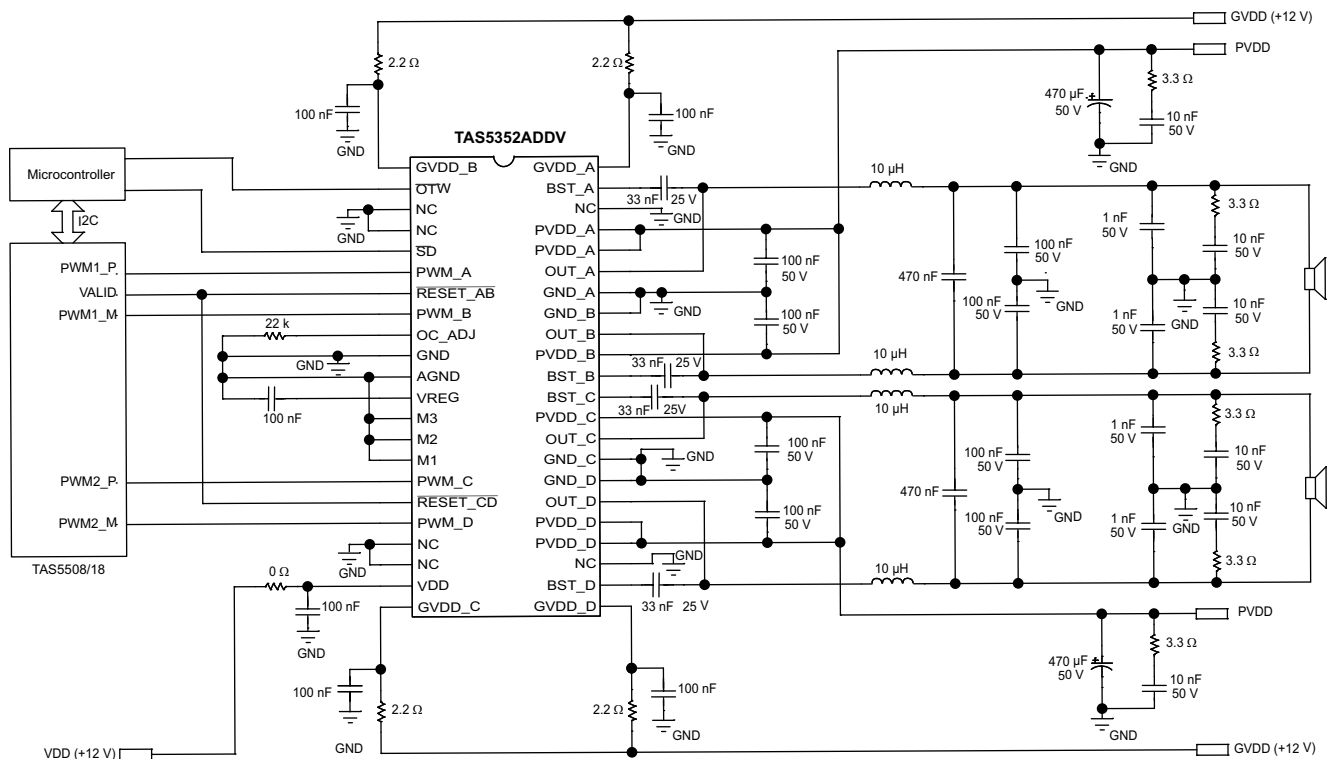

Copyright © 2016, Texas Instruments Incorporated

Figure 14. Typical Differential (2N) BTL Application With AD Modulation Filters

8.2.1.1 Design Requirements

Table 5 lists the design requirements for this example.

Table 5. Design Requirements for Typical Differential BTL

DESIGN PARAMETER	EXAMPLE
Low Power (Pullup) Supply	3.3 V
Mid Power Supply (GVDD, VDD)	12 V
High Power Supply (PVDD)	12 – 36 V

Table 5. Design Requirements for Typical Differential BTL (continued)

DESIGN PARAMETER	EXAMPLE
PWM Inputs	INPUT_A = 0 – 3.3 V PWM
	INPUT_B = 0 – 3.3 V PWM
	INPUT_C = 0 – 3.3 V PWM
	INPUT_D = 0 – 3.3 V PWM
Speaker Impedance	4 – 8 Ω

8.2.1.2 Detailed Design Procedure

8.2.1.2.1 PCB Material Recommendation

FR-4 Glass Epoxy material with 2-oz. (70- μ m) copper is recommended when using the TAS5352A. The use of this material can provide for higher power output, improved thermal performance, and better EMI margin (due to lower PCB trace inductance).

8.2.1.2.2 PVDD Capacitor Recommendation

The large capacitors used in conjunction with each full-bridge, are referred to as the PVDD Capacitors. These capacitors should be selected for proper voltage margin and adequate capacitance to support the power requirements. In practice, with a well designed system power supply, 1000- μ F, 50-V capacitors will support more applications. The PVDD capacitors should be low-ESR type because they are used in a circuit associated with high-speed switching.

8.2.1.2.3 Decoupling Capacitor Recommendations

To design an amplifier that has robust performance, passes regulatory requirements, and exhibits good audio performance, good-quality decoupling capacitors should be used. In practice, X7R should be used in this application.

The voltage of the decoupling capacitors should be selected in accordance with good design practices. Temperature, ripple current, and voltage overshoot must be considered. This fact is particularly true in the selection of the 0.1 μ F that is placed on the power supply to each half-bridge. It must withstand the voltage overshoot of the PWM switching, the heat generated by the amplifier during high power output, and the ripple current created by high power output. A minimum voltage rating of 50 V is required for use with a 34.5-V power supply.

Detailed information regarding LC filter design and the impact on amplifier performance can be found in the application note [LC Filter Design](#) (SLAA701).

8.2.1.3 Application Curves

Relevant performance plots for TAS5352A in BTL configuration are shown in [BTL Configuration](#).

Table 6. Relevant Performance Plots, BTL Configuration

PLOT TITLE	FIGURE NUMBER
Total Harmonic Distortion + Noise vs. Output power	Figure 1
Output Power vs. Supply Voltage	Figure 2
Unclipped Output Power vs. Supply Voltage	Figure 3
System Efficiency vs. Output Power	Figure 4
System Power Loss vs. Output Power	Figure 5
System Output Power vs. Case Temperature	Figure 6
Noise Amplitude vs. Frequency	Figure 7

8.2.2 BTL Application With AD Modulation Filters – 1N

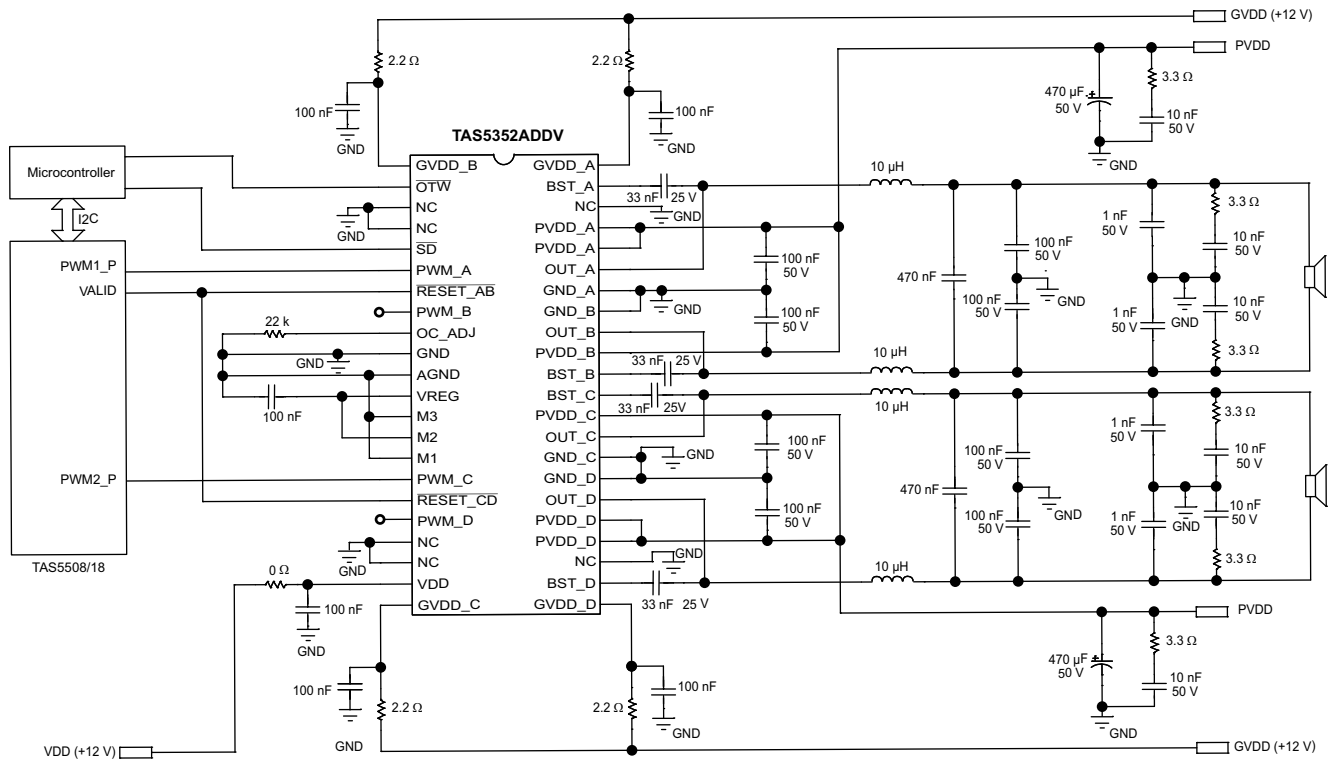

Copyright © 2016, Texas Instruments Incorporated

Figure 15. Typical Non-Differential (1N) BTL Application With AD Modulation Filters

8.2.2.1 Design Requirements

Table 7 lists the design requirements for this example.

Table 7. Design Requirements for Typical Non-Differential BTL

DESIGN PARAMETER	EXAMPLE
Low Power (Pullup) Supply	3.3 V
Mid Power Supply (GVDD, VDD)	12 V
High Power Supply (PVDD)	12 – 36 V
PWM Inputs	INPUT_A = 0 – 3.3 V PWM
	INPUT_B = N/C
	INPUT_C = 0 – 3.3 V PWM
	INPUT_D = N/C
Speaker Impedance	4 – 8 Ω

8.2.3.1 Design Requirements

Table 8 lists the design requirements for this example.

Table 8. Design Requirements for Typical SE

DESIGN PARAMETER	EXAMPLE
Low Power (Pullup) Supply	3.3 V
Mid Power Supply (GVDD, VDD)	12 V
High Power Supply (PVDD)	12 – 36 V
PWM Inputs	INPUT_A = 0 – 3.3 V PWM
	INPUT_B = 0 – 3.3 V PWM
	INPUT_C = 0 – 3.3 V PWM
	INPUT_D = 0 – 3.3 V PWM
Speaker Impedance	3 – 4 Ω

8.2.3.2 Application Curves

Relevant performance plots for TAS5352A in SE configuration are shown in [SE Configuration](#).

Table 9. Relevant Performance Plots, SE Configuration

PLOT TITLE	FIGURE NUMBER
Total Harmonic Distortion + Noise vs. Output Power	Figure 8
Output Power vs. Supply Voltage	Figure 9
Power Output vs. Case Temperature	Figure 10

8.2.4 PBTL Application With AD Modulation Filters

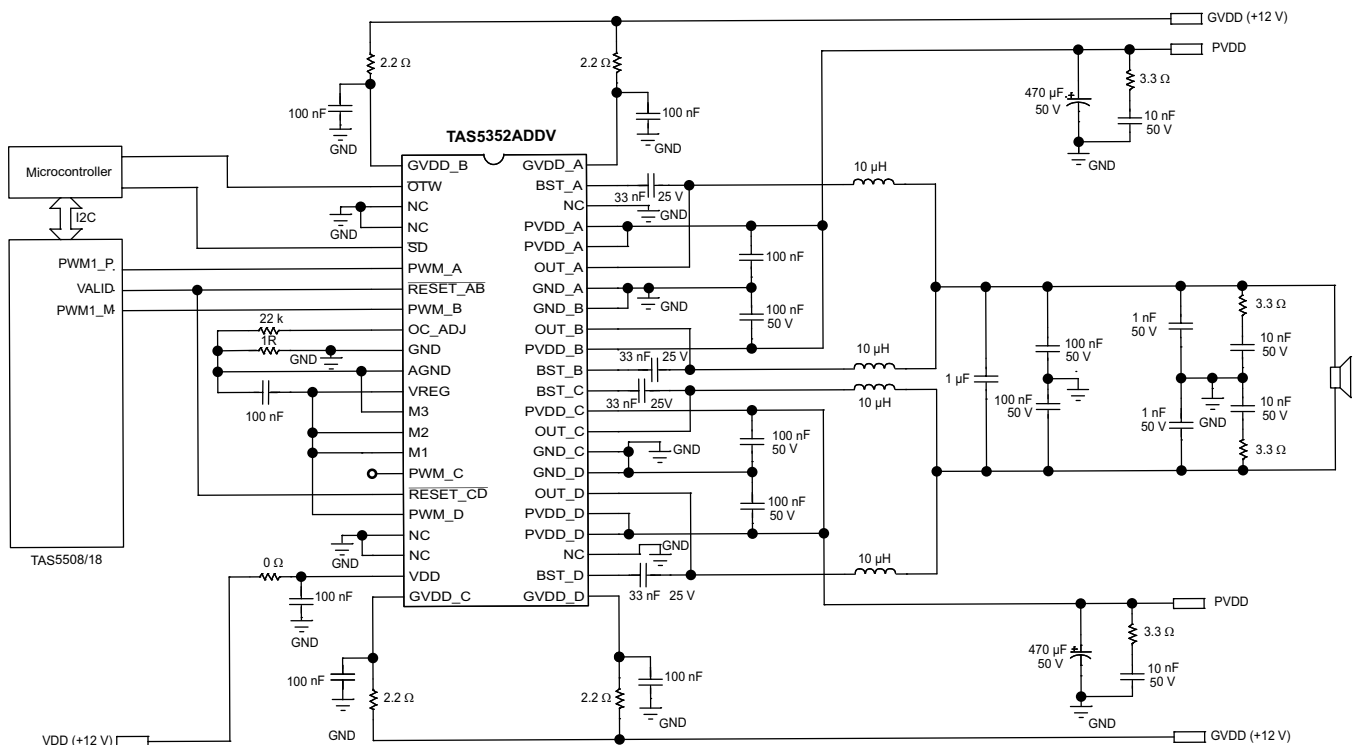

Copyright © 2016, Texas Instruments Incorporated

Figure 17. Typical Differential (2N) PBTL Application With AD Modulation Filters

8.2.4.1 Design Requirements

Table 10 lists the design requirements for this example.

Table 10. Design Requirements for Typical Differential PBTL

DESIGN PARAMETER	EXAMPLE
Low Power (Pullup) Supply	3.3 V
Mid Power Supply (GVDD, VDD)	12 V
High Power Supply (PVDD)	12 – 36 V
PWM Inputs	INPUT_A = 0 – 3.3 V PWM
	INPUT_B = 0 – 3.3 V PWM
	INPUT_C = N/C
	INPUT_D = 3.3 V PWM
Speaker Impedance	2 – 3 Ω

8.2.4.2 Application Curves

Relevant performance plots for TAS5352A in PBTL configuration are shown in [PBTL Configuration](#).

Table 11. Relevant Performance Plots, PBTL Configuration

PLOT TITLE	FIGURE NUMBER
Total Harmonic Distortion + Noise vs. Output Power	Figure 11
Output Power vs. Supply Voltage	Figure 12
Power Output vs. Case Temperature	Figure 13

8.2.5 Non-Differential PBTL Application

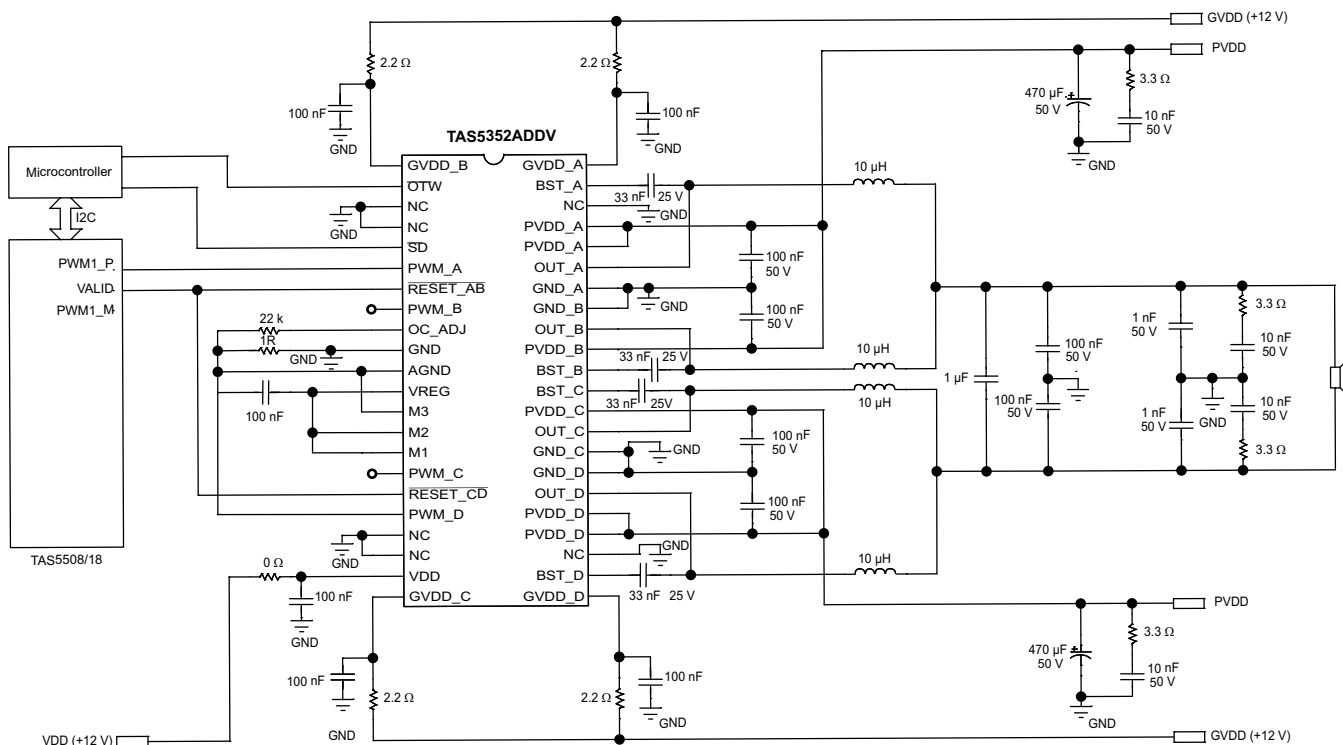

Copyright © 2016, Texas Instruments Incorporated

Figure 18. Typical Non-Differential (1N) PBTL Application

8.2.5.1 Design Requirements

Table 12 lists the design requirements for this example.

Table 12. Design Requirements for Typical Non-Differential PBTL

DESIGN PARAMETER	EXAMPLE
Low Power (Pullup) Supply	3.3 V
Mid Power Supply (GVDD, VDD)	12 V
High Power Supply (PVDD)	12 – 36 V
PWM Inputs	INPUT_A = 0 – 3.3 V PWM
	INPUT_B = N/C
	INPUT_C = N/C
	INPUT_D = GND
Speaker Impedance	2 – 3 Ω

8.3 System Example

Figure 19 shows a block diagram for a typical audio system using the TAS5352A. The TAS5518 is an 8-channel digital audio PWM processor.

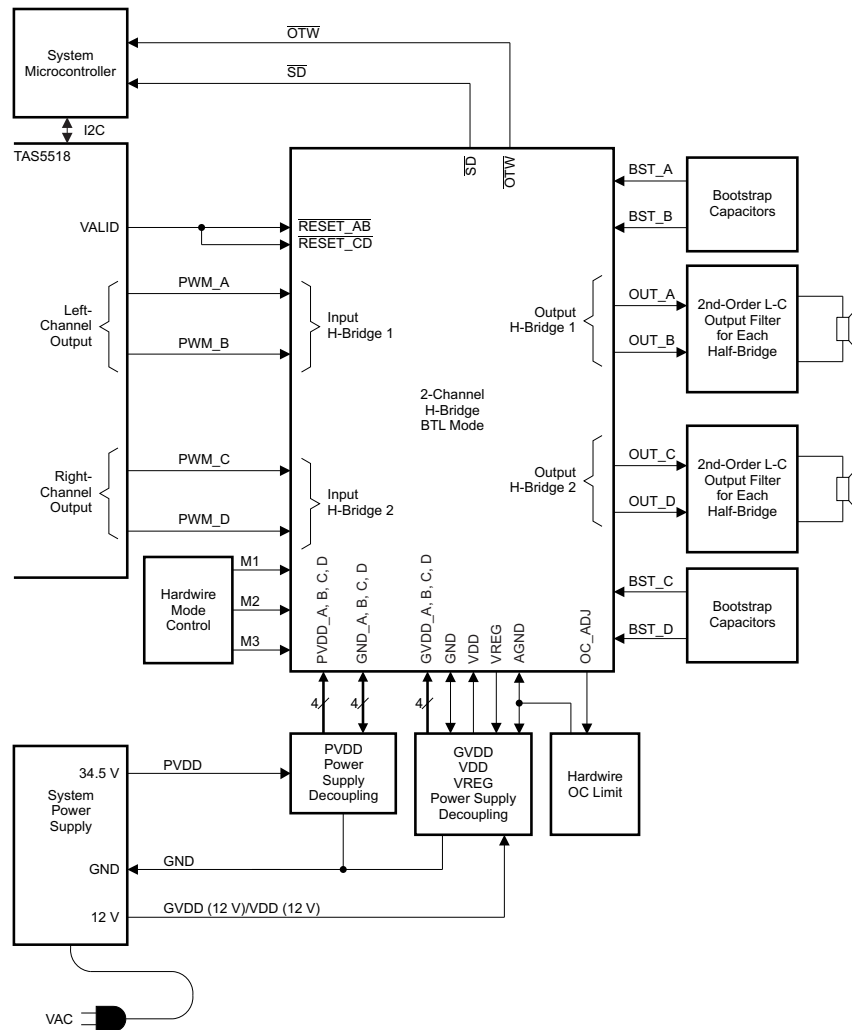

80047-02
Copyright © 2016, Texas Instruments Incorporated

Figure 19. Typical System Block Diagram

9 Power Supply Recommendations

To facilitate system design, the TAS5352A needs only a 12-V supply in addition to the (typical) 34.5-V power-stage supply. An internal voltage regulator provides suitable voltage levels for the digital and low-voltage analog circuitry. Additionally, all circuitry requiring a floating voltage supply, for example, the high-side gate drive, is accommodated by built-in bootstrap circuitry requiring only an external capacitor for each half-bridge.

To provide outstanding electrical and acoustical characteristics, the PWM signal path including gate drive and output stage is designed as identical, independent half-bridges. For this reason, each half-bridge has separate gate drive supply (GVDD_X), bootstrap pins (BST_X), and power-stage supply pins (PVDD_X). Furthermore, an additional pin (VDD) is provided as supply for all common circuits. Although supplied from the same 12-V source, TI highly recommends separating GVDD_A, GVDD_B, GVDD_C, GVDD_D, and VDD on the printed-circuit board (PCB) by RC filters (see the diagrams in [Typical Applications](#) for details). These RC filters provide the recommended high-frequency isolation. Pay special attention when placing all decoupling capacitors as close to their associated pins as possible. In general, inductance between the power supply pins and decoupling capacitors must be avoided (see reference board documentation for additional information).

For a properly functioning bootstrap circuit, a small ceramic capacitor must be connected from each bootstrap pin (BST_X) to the power-stage output pin (OUT_X). When the power-stage output is low, the bootstrap capacitor is charged through an internal diode connected between the gate-drive power-supply pin (GVDD_X) and the bootstrap pin. When the power-stage output is high, the bootstrap capacitor potential is shifted above the output potential and thus provides a suitable voltage supply for the high-side gate driver. In an application with PWM switching frequencies in the range from 352 kHz to 384 kHz, TI recommends using 33-nF ceramic capacitors, size 0603 or 0805, for the bootstrap supply. These 33-nF capacitors ensure sufficient energy storage, even during minimal PWM duty cycles, to keep the high-side power stage FET (LDMOS) fully turned on during the remaining part of the PWM cycle. In an application running at a reduced switching frequency, generally 192 kHz, the bootstrap capacitor might need to be increased in value.

Pay special attention to the power-stage power supply; this includes component selection, PCB placement, and routing. As indicated, each half-bridge has independent power-stage supply pins (PVDD_X). For optimal electrical performance, EMI compliance, and system reliability, it is important that each PVDD_X pin is decoupled with a 100-nF ceramic capacitor placed as close as possible to each supply pin. TI recommends following the PCB layout of the TAS5352A reference design. For additional information on recommended power supply and required components, see the application diagrams given previously in this data sheet.

The 12-V supply should be from a low-noise, low-output-impedance voltage regulator. Likewise, the 34.5-V power-stage supply is assumed to have low output impedance and low noise. The power-supply sequence is not critical as facilitated by the internal power-on-reset circuit. Moreover, the TAS5352A is fully protected against erroneous power-stage turnon due to parasitic gate charging. Thus, voltage-supply ramp rates (dV/dt) are non-critical within the specified range (see the [Recommended Operating Conditions](#)).

10 Layout

10.1 Layout Guidelines

- Use an unbroken ground plane to have good low impedance and inductance return path to the power supply for power and audio signals.
- Maintain a contiguous ground plane from the ground pins to the PCB area surrounding the device for as many of the ground pins as possible, because the ground pins are the best conductors of heat in the package.
- PCB layout, audio performance and EMI are linked closely together.
- Routing the audio input must be kept short and together with the accompanied audio source ground.
- The small bypass capacitors on the PVDD lines of the DUT be placed as close the PVDD pins as possible.
- A local ground area underneath the device is important to keep solid to minimize ground bounce.
- Orient the passive component so that the narrow end of the passive component is facing the TAS5352A device, unless the area between two pads of a passive component is large enough to allow copper to flow in between the two pads.
- Avoid placing other heat producing components or structures near the TAS5352A device.
- Avoid cutting off the flow of heat from the TAS5352A device to the surrounding ground areas with traces or via strings, especially on output side of device.

10.2 Layout Example

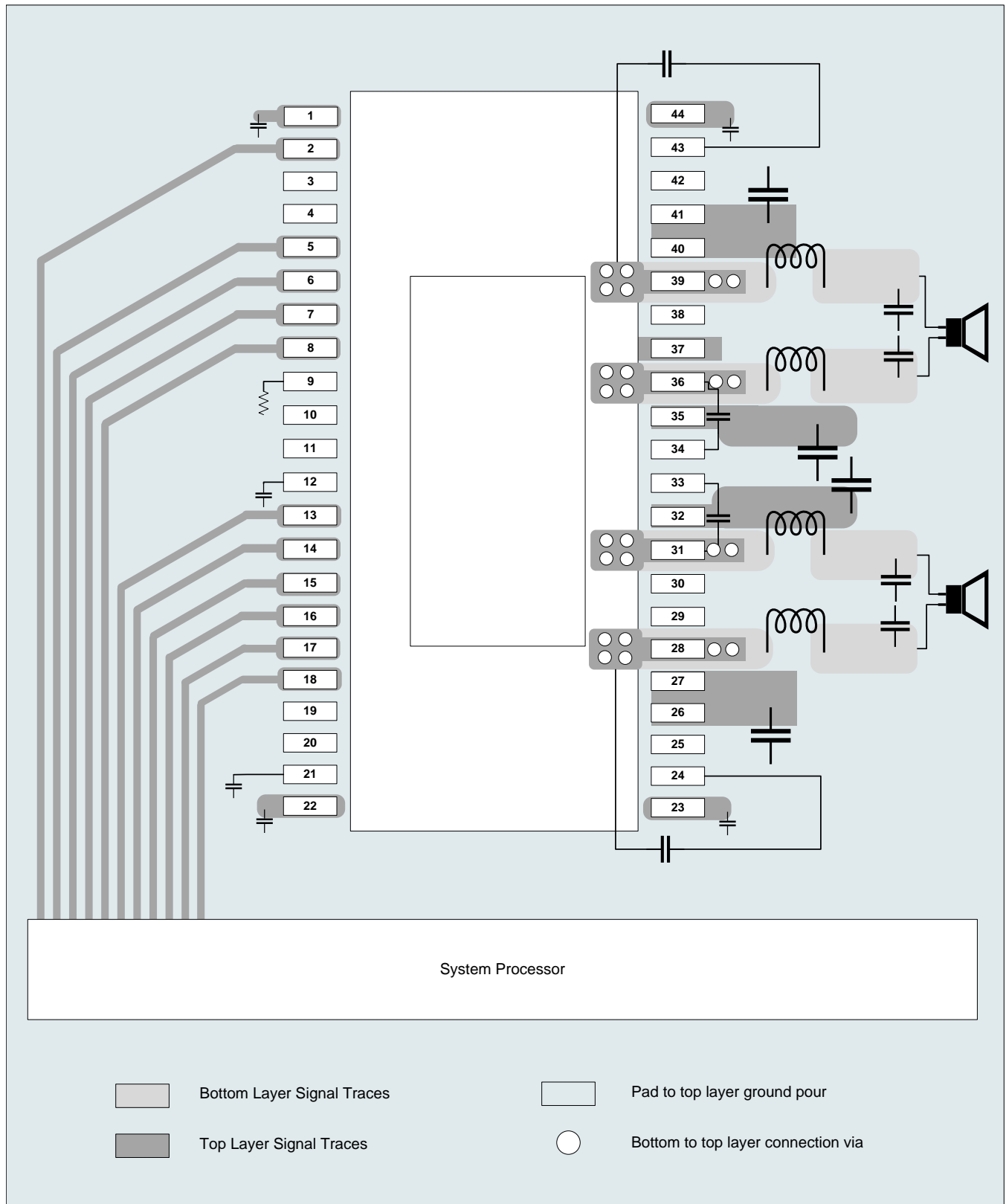

Figure 20. Layout Recommendation

11 Device and Documentation Support

11.1 Device Support

11.1.1 Development Support

For development support, see the following:

- [TAS5518](#)
- [TAS5086](#)
- [TAS5508](#)

11.2 Documentation Support

11.2.1 Related Documentation

For related documentation, see the following:

- [LC Filter Design](#) (SLAA701)
- [TAS5352A EVM User's Guide](#) (SLAU244)

11.3 Receiving Notification of Documentation Updates

To receive notification of documentation updates, navigate to the device product folder on ti.com. In the upper right corner, click on *Alert me* to register and receive a weekly digest of any product information that has changed. For change details, review the revision history included in any revised document.

11.4 Community Resources

The following links connect to TI community resources. Linked contents are provided "AS IS" by the respective contributors. They do not constitute TI specifications and do not necessarily reflect TI's views; see TI's [Terms of Use](#).

TI E2E™ Online Community *TI's Engineer-to-Engineer (E2E) Community*. Created to foster collaboration among engineers. At e2e.ti.com, you can ask questions, share knowledge, explore ideas and help solve problems with fellow engineers.

Design Support *TI's Design Support* Quickly find helpful E2E forums along with design support tools and contact information for technical support.

11.5 Trademarks

E2E is a trademark of Texas Instruments.
All other trademarks are the property of their respective owners.

11.6 Electrostatic Discharge Caution



These devices have limited built-in ESD protection. The leads should be shorted together or the device placed in conductive foam during storage or handling to prevent electrostatic damage to the MOS gates.

11.7 Glossary

[SLYZ022](#) — *TI Glossary*.

This glossary lists and explains terms, acronyms, and definitions.

12 Mechanical, Packaging, and Orderable Information

The following pages include mechanical, packaging, and orderable information. This information is the most current data available for the designated devices. This data is subject to change without notice and revision of this document. For browser-based versions of this data sheet, refer to the left-hand navigation.

TAPE AND REEL INFORMATION

QUADRANT ASSIGNMENTS FOR PIN 1 ORIENTATION IN TAPE



*All dimensions are nominal

Device	Package Type	Package Drawing	Pins	SPQ	Reel Diameter (mm)	Reel Width W1 (mm)	A0 (mm)	B0 (mm)	K0 (mm)	P1 (mm)	W (mm)	Pin1 Quadrant
TAS5352ADDVR	HTSSOP	DDV	44	2000	330.0	24.4	8.6	15.6	1.8	12.0	24.0	Q1

TAPE AND REEL BOX DIMENSIONS

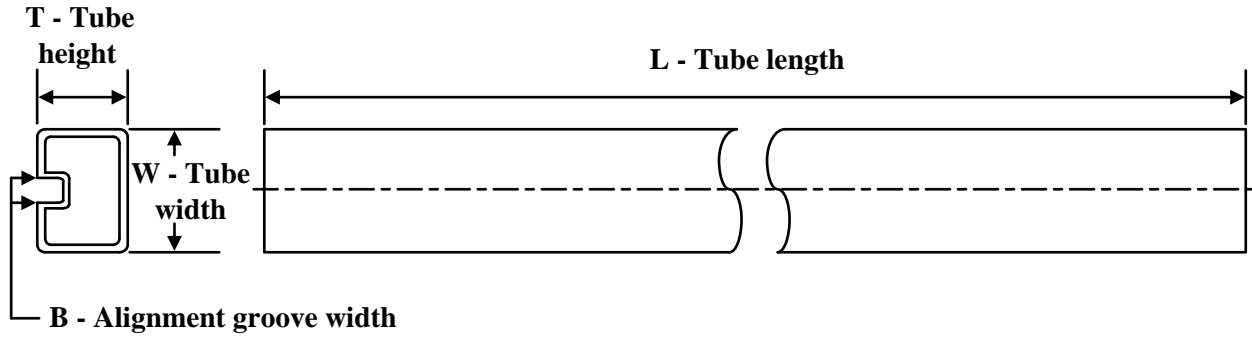

*All dimensions are nominal

Device	Package Type	Package Drawing	Pins	SPQ	Length (mm)	Width (mm)	Height (mm)
TAS5352ADDVR	HTSSOP	DDV	44	2000	350.0	350.0	43.0

TUBE

*All dimensions are nominal

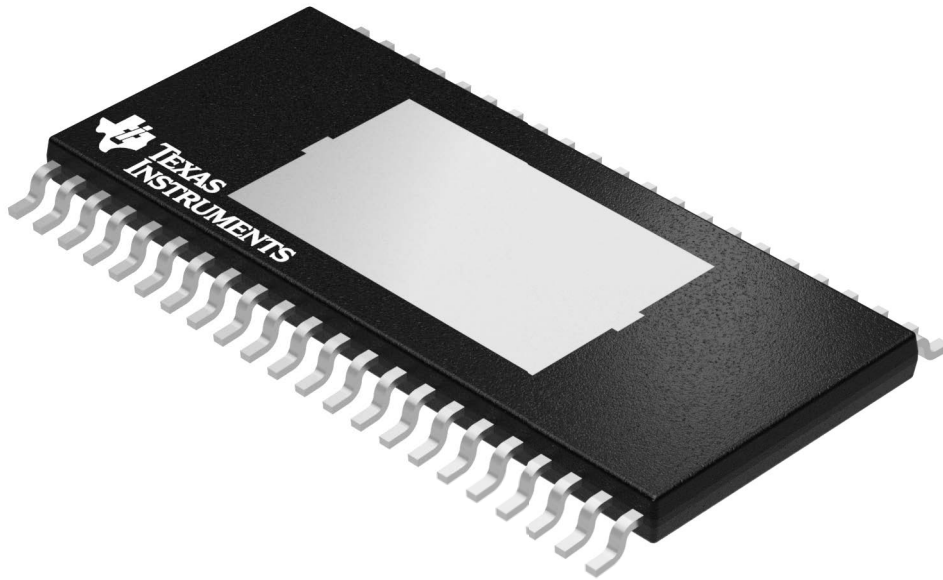
Device	Package Name	Package Type	Pins	SPQ	L (mm)	W (mm)	T (μm)	B (mm)
TAS5352ADDV	DDV	HTSSOP	44	35	530	11.89	3600	4.9



Images above are just a representation of the package family, actual package may vary.
Refer to the product data sheet for package details.

MECHANICAL DATA

DDV (R-PDSO-G44) PowerPAD™ PLASTIC SMALL OUTLINE PACKAGE (DIE DOWN)

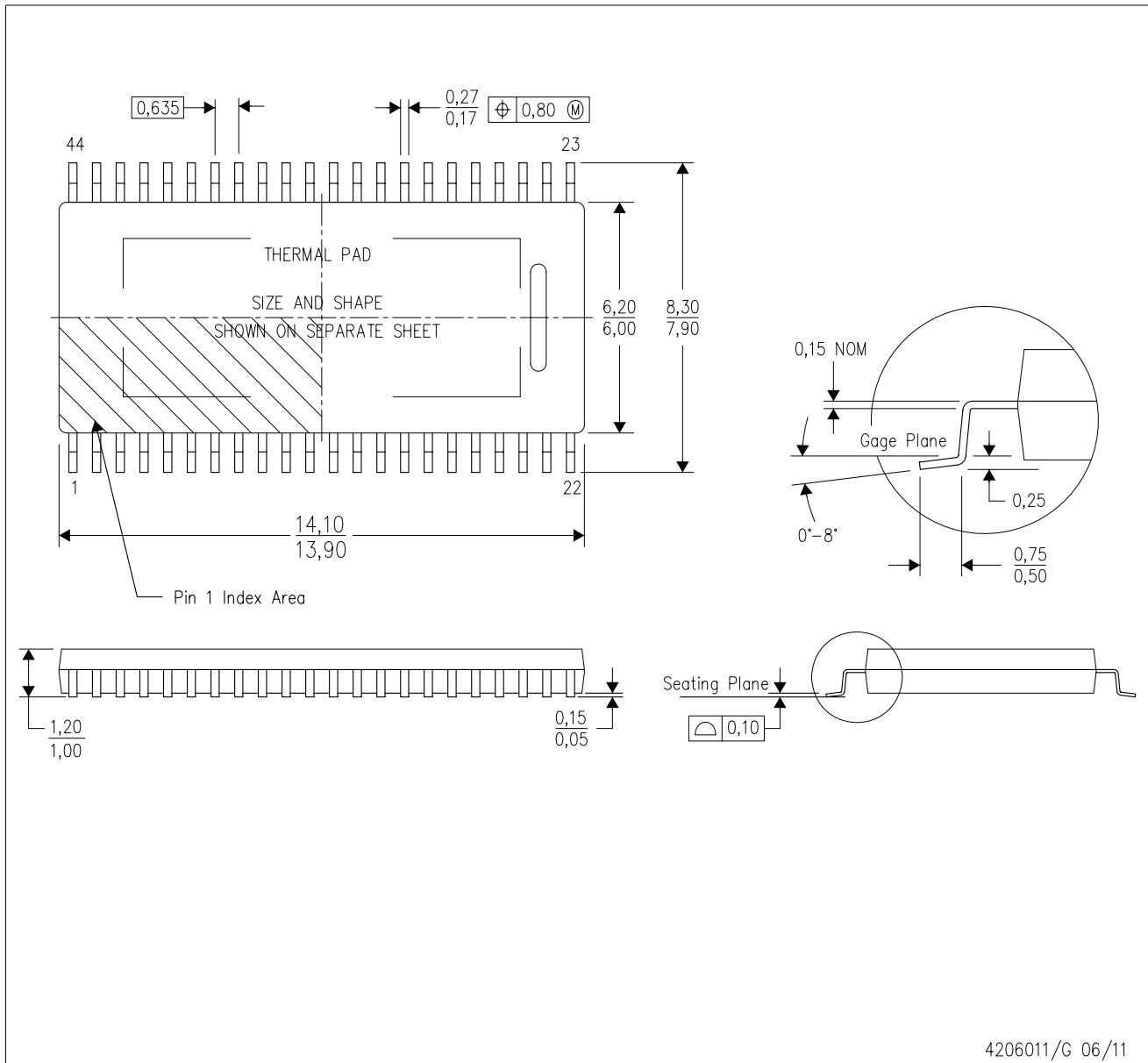

- NOTES:
- All linear dimensions are in millimeters. Dimensioning and tolerancing per ASME Y14.5M-1994.
 - This drawing is subject to change without notice.
 - Body dimensions do not include mold flash or protrusion not to exceed 0,15.
 - This package is designed to be attached directly to an external heatsink. Refer to Technical Brief, PowerPad Thermally Enhanced Package, Texas Instruments Literature No. SLMA002 for information regarding recommended board layout. This document is available at www.ti.com <<http://www.ti.com>>. See the product data sheet for details regarding the exposed thermal pad dimensions.

PowerPAD is a trademark of Texas Instruments.

THERMAL PAD MECHANICAL DATA

DDV (R-PDSO-G44)

PowerPAD™ SMALL OUTLINE PACKAGE

THERMAL INFORMATION

This PowerPAD™ package incorporates an exposed thermal pad that is designed to be attached directly to an external heatsink. This design optimizes the heat transfer from the integrated circuit (IC).

For additional information on the PowerPAD package and how to take advantage of its heat dissipating abilities, refer to Technical Brief, PowerPAD Thermally Enhanced Package, Texas Instruments Literature No. SLMA002 and Application Brief, PowerPAD Made Easy, Texas Instruments Literature No. SLMA004. Both documents are available at www.ti.com.

The exposed thermal pad dimensions for this package are shown in the following illustration.

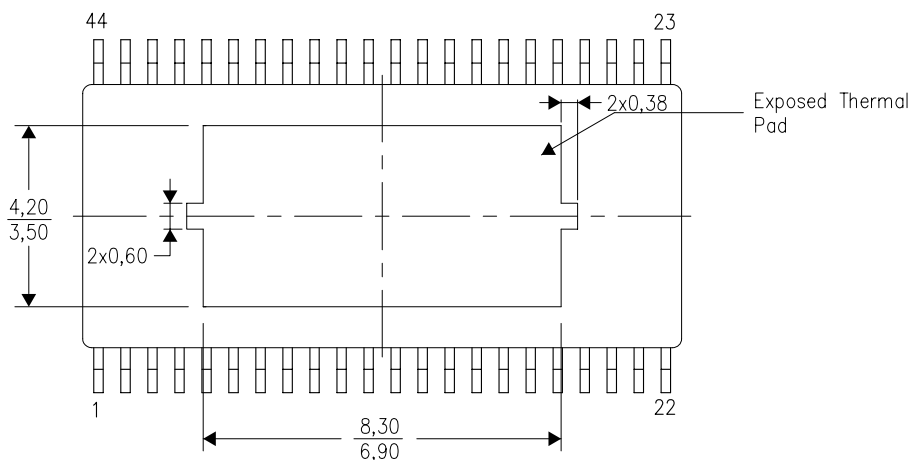

Top View

Exposed Thermal Pad Dimensions

4206975-2/D 07/11

NOTE: All linear dimensions are in millimeters

PowerPAD is a trademark of Texas Instruments

IMPORTANT NOTICE AND DISCLAIMER

TI PROVIDES TECHNICAL AND RELIABILITY DATA (INCLUDING DATA SHEETS), DESIGN RESOURCES (INCLUDING REFERENCE DESIGNS), APPLICATION OR OTHER DESIGN ADVICE, WEB TOOLS, SAFETY INFORMATION, AND OTHER RESOURCES "AS IS" AND WITH ALL FAULTS, AND DISCLAIMS ALL WARRANTIES, EXPRESS AND IMPLIED, INCLUDING WITHOUT LIMITATION ANY IMPLIED WARRANTIES OF MERCHANTABILITY, FITNESS FOR A PARTICULAR PURPOSE OR NON-INFRINGEMENT OF THIRD PARTY INTELLECTUAL PROPERTY RIGHTS.

These resources are intended for skilled developers designing with TI products. You are solely responsible for (1) selecting the appropriate TI products for your application, (2) designing, validating and testing your application, and (3) ensuring your application meets applicable standards, and any other safety, security, regulatory or other requirements.

These resources are subject to change without notice. TI grants you permission to use these resources only for development of an application that uses the TI products described in the resource. Other reproduction and display of these resources is prohibited. No license is granted to any other TI intellectual property right or to any third party intellectual property right. TI disclaims responsibility for, and you will fully indemnify TI and its representatives against, any claims, damages, costs, losses, and liabilities arising out of your use of these resources.

TI's products are provided subject to [TI's Terms of Sale](#) or other applicable terms available either on [ti.com](https://www.ti.com) or provided in conjunction with such TI products. TI's provision of these resources does not expand or otherwise alter TI's applicable warranties or warranty disclaimers for TI products.

TI objects to and rejects any additional or different terms you may have proposed.

Mailing Address: Texas Instruments, Post Office Box 655303, Dallas, Texas 75265
Copyright © 2023, Texas Instruments Incorporated

Looking for pricing, stock, or lifecycle information?

Click below to explore more details on WIN SOURCE:

 [View TAS5352ADDVR on WIN SOURCE](#)

 [Texas Instruments](#) Information

Optimize Your Supply Chain with WIN SOURCE Solutions

-  Global Sourcing Solution
-  Obsolete Management
-  Cost Control Management
-  Shortage Management
-  Alternative Solution
-  Excess Inventory Management