

TOSHIBA BIPOLAR LINEAR INTEGRATED CIRCUIT SILICON MONOLITHIC

TA7291P, TA7291S/SG, TA7291F/FG

BRIDGE DRIVER

The TA7291P / S/SG / F/FG are Bridge Driver with output voltage control.

FEATURES

- 4 modes available (CW / CCW / STOP / BRAKE)
- Output current: P type 1.0 A (AVE.) 2.0 A (PEAK)
 S/SG,/ F/FG type 0.4 A (AVE.) 1.2 A (PEAK)
- Wide range of operating voltage: $V_{CC} (opr.) = 4.5\sim 20\text{ V}$
 $V_S (opr.) = 0\sim 20\text{ V}$
 *Please consider the internal loss (V_{sat}) to operate the IC though minimum V_S is defined zero.
 $V_{ref} (opr.) = 0\sim 20\text{ V}$
- Build in thermal shutdown, over current protector and punch = through current restriction circuit.
- Stand-by mode available (STOP MODE)
- Hysteresis for all inputs.

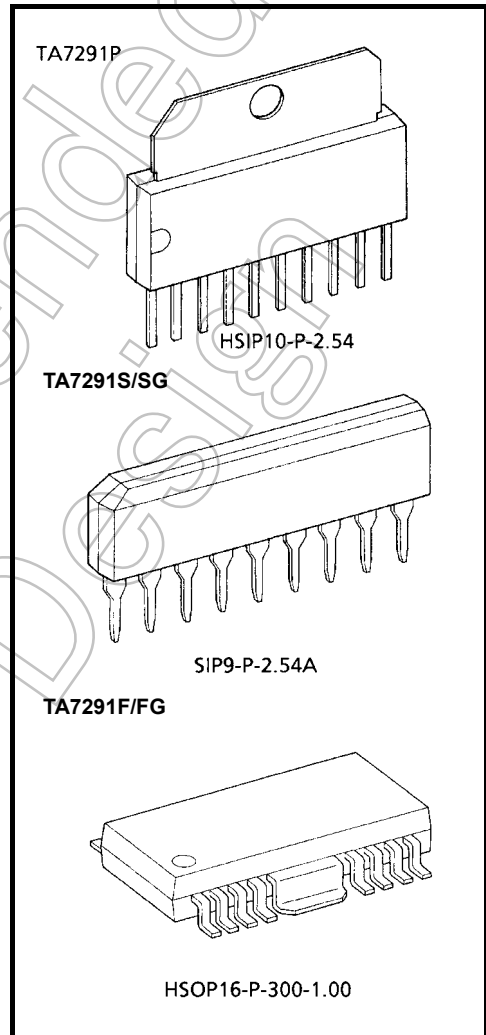

TA7291P, TA7291SG/FG:
 TA7291P Sn plated product including Pb.
 TA7291SG/FG is Pb free product.
 The following conditions apply to solderability:

*Solderability

1. Use of Sn-37Pb solder bath
 *solder bath temperature=230 degrees
 *dipping time=5seconds
 *number of times=once
 *use of R-type flux
2. Use of Sn-3.0Ag-0.5Cu solder bath
 *solder bath temperature=245 degrees
 *dipping time=5seconds
 *the number of times=once
 *use of R-type flux

Weight	
HSIP10-P-2.54	: 2.47 g (Typ.)
SIP9-P-2.54A	: 0.92 g (Typ.)
HSOP16-P-300-1.00	: 0.50 g (Typ.)

BLOCK DIAGRAM

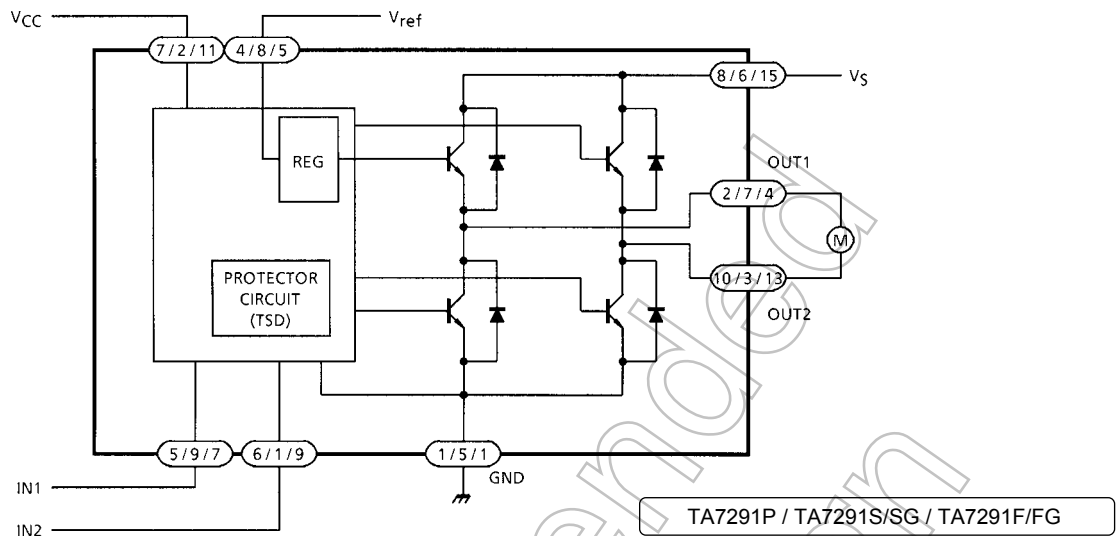

PIN FUNCTION

P	PIN No.		SYMBOL	FUNCTION DESCRIPTION
	S/SG	F/FG		
7	2	11	V _{CC}	Supply voltage terminal for Logic
8	6	15	V _S	Supply voltage terminal for Motor driver
4	8	5	V _{ref}	Supply voltage terminal for control
1	5	1	GND	GND terminal
5	9	7	IN1	Input terminal
6	1	9	IN2	Input terminal
2	7	4	OUT1	Output terminal
10	3	13	OUT2	Output terminal

P Type: Pin (3), (9): NC
 S/SG Type: PIN (4): NC
 F/FG Type: PIN (2), (3), (6), (8), (10), (12), (14), and (16): NC
 For F/FG Type, We recommend FIN to be connected to the GND.

FUNCTION

INPUT		OUTPUT		MODE
IN1	IN2	OUT1	OUT2	
0	0	∞	∞	STOP
1	0	H	L	CW / CCW
0	1	L	H	CCW / CW
1	1	L	L	BRAKE

∞: High impedance

Note: Inputs are all high active type

ABSOLUTE MAXIMUM RATINGS (Ta = 25°C)

CHARACTERISTIC		SYMBOL	RATING	UNIT
Supply Voltage		V _{CC}	25	V
Motor Drive Voltage		V _S	25	V
Reference Voltage		V _{ref}	25	V
Output Current	PEAK	P Type	2.0	A
		S/SG, F/FG Type	1.2	
	AVE.	P Type	1.0	
		S/SG, F/FG Type	0.4	
Power Dissipation	P Type	P _D	12.5 (Note 1)	W
	S/SG Type		0.95 (Note 2)	
	F/FG Type		1.4 (Note 3)	
Operating Temperature		T _{opr}	-30~75	°C
Storage Temperature		T _{stg}	-55~150	°C

Note 1: T_c = 25°C (TA7291P/PG)

Note 2: No heat sink

Note 3: PCB (60 × 30 × 1.6 mm, occupied copper area in excess of 50%) Mounting Condition.

Wide range of operating voltage: V_{CC} (opr.) = 4.5~20 V

V_S (opr.) = 0~20 V

V_{ref} (opr.) = 0~20 V

V_{ref} ≤ V_S

ELECTRICAL CHARACTERISTICS

(Unless otherwise specified, Ta = 25°C, VCC = 12 V, VS = 18 V)

CHARACTERISTIC			SYMBOL	TEST CIR-CUIT	TEST CONDITION	MIN	TYP.	MAX	UNIT		
Supply Current			ICC1	1	Output OFF, CW / CCW mode	—	8.0	13.0	mA		
			ICC2		Output OFF, Stop mode	—	0	50	μA		
			ICC3		Output OFF, Brake mode	—	6.5	10.0	mA		
Input Operating Voltage		1 (High)	VIN1	2	Tj = 25°C	3.5	—	5.5	V		
		2 (Low)	VIN2			GND	—	0.8			
Input Current			IIN		VIN = 3.5 V, Sink mode	—	3	10	μA		
Input Hysteresis Voltage			ΔVT		—	—	0.7	—	V		
Saturation Voltage	P / S/SG / F/FG Type	Upper Side	VSAT U-1	3	Vref = VS, VOUT - VS measure IO = 0.2 A, CW / CCW mode	—	0.9	1.2	V		
		Lower Side	VSAT L-1		Vref = VS, VOUT - GND measure IO = 0.2 A, CW / CCW mode	—	0.8	1.2			
	S/SG / F/FG Type	Upper Side	VSAT U-2		Vref = VS, VOUT - VS measure IO = 0.4 A, CW / CCW mode	—	1.0	1.35			
		Lower Side	VSAT L-2		Vref = VS, VOUT - GND measure IO = 0.4 A, CW / CCW mode	—	0.9	1.35			
	P Type	Upper Side	VSAT U-3		Vref = VS, VOUT - VS measure IO = 1.0 A, CW / CCW mode	—	1.3	1.8			
		Lower Side	VSAT L-3		Vref = VS, VOUT - GND measure IO = 1.0 A, CW / CCW mode	—	1.2	1.85			
Output Voltage (Upper Side)			S/SG / F/FG Type	VSAT U-1'	Vref = 10 V VOUT - GND measure, IO = 0.2 A, CW / CCW mode	—	11.2	—	V		
				VSAT U-2'	Vref = 10 V VOUT - GND measure, IO = 0.4 A, CW / CCW mode	10.4	10.9	12.2			
			P Type	VSAT U-3'	Vref = 10 V VOUT - GND measure, IO = 0.5 A, CW / CCW mode	—	11.0	—			
				VSAT U-4'	Vref = 10 V VOUT - GND measure, IO = 1.0 A, CW / CCW mode	10.2	10.7	12.0			
Leakage Current		Upper Side	IL U	4	VL = 25 V	—	—	50	μA		
		Lower Side	IL L		VL = 25 V	—	—	50			
Diode Forward Voltage			S/SG / F/FG Type	Upper Side	VF U-1	5	IF = 0.4 A	—	1.5	V	
			P Type	Lower Side	VF U-2		IF = 1 A	—	2.5		—
			S/SG / F/FG Type	Upper Side	VF L-1		IF = 0.4 A	—	0.9		—
			P Type	Lower Side	VF L-2		IF = 1 A	—	1.2		—
Reference Current			Iref	2	Vref = 10 V, Source mode	—	20	40	μA		

TEST CIRCUIT 1

I_{CC1}, I_{CC2}, I_{CC3}

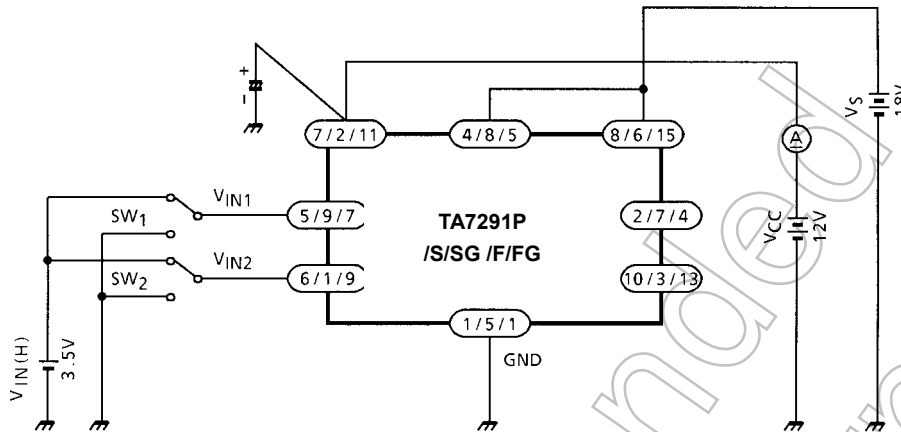

Note: HEAT FIN of TA7291F/FG is connected to GND.

TEST CIRCUIT 2

V_{IN 1}, V_{IN 2}, I_{IN}, ΔV_T, I_{ref}

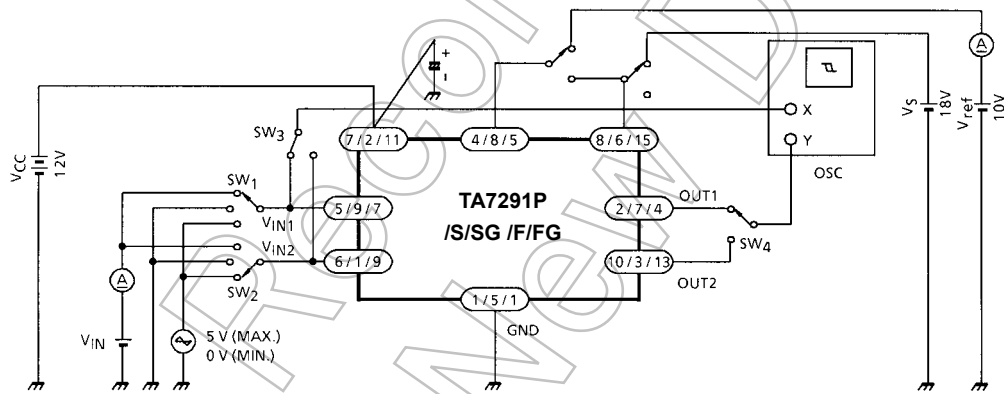

TA7291P / TA7291S/SG / TA7291F/FG

Note: HEAT FIN of TA7291F/FG is connected to GND.

TEST CIRCUIT 3

$V_{SAT U-1, 2, 3}$ $V_{SAT L-1, 2, 3}$ $V_{SAT U-1', 2', 3', 4'}$

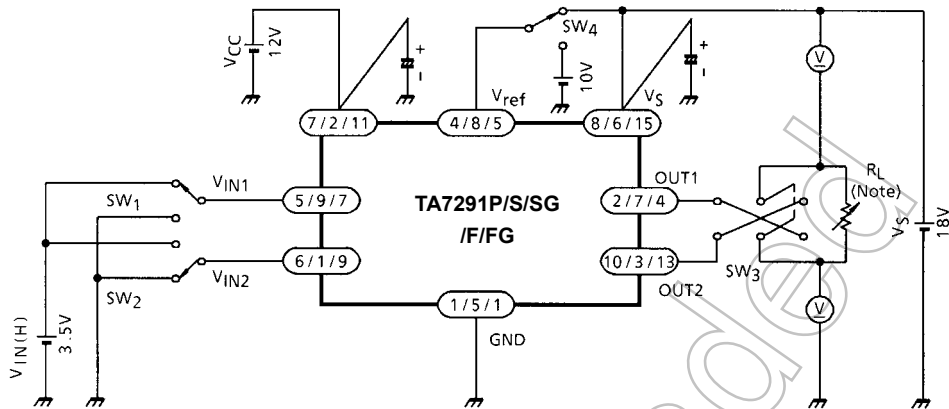

Note: I_{OUT} calibration is required to adjust specified values of test conditions by R_L .
($I_{OUT} = 0.2 A / 0.4 A / 0.5 A / 1.0 A$)

Note: HEAT FIN of TA7291F/FG is connected to GND.

TEST CIRCUIT 4

I_L U, L

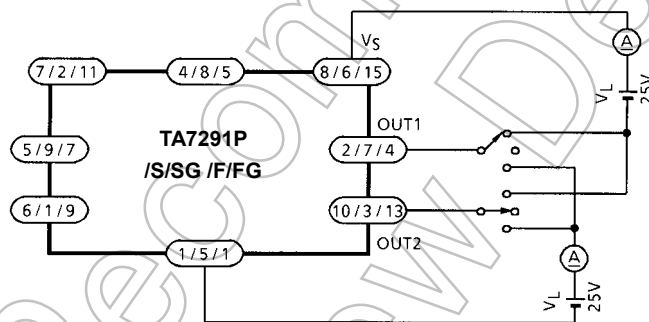

TA7291P / TA7291S/SG / TA7291F/FG

Note: HEAT FIN of TA7291F/FG is connected to GND.

TEST CIRCUIT 5

$V_{FU-1, 2}$ $V_{FL-1, 2}$

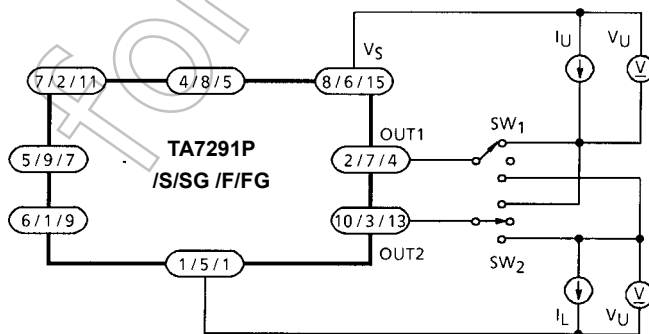

TA7291P

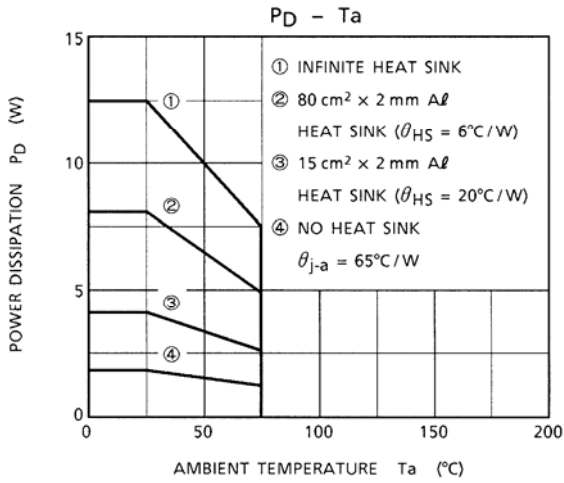

TA7291P

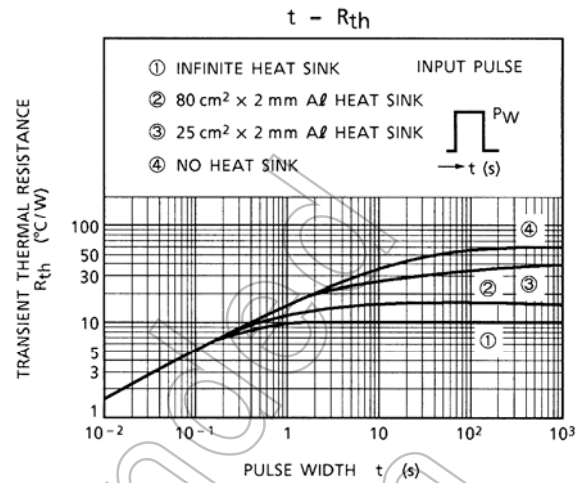

TA7291S/SG

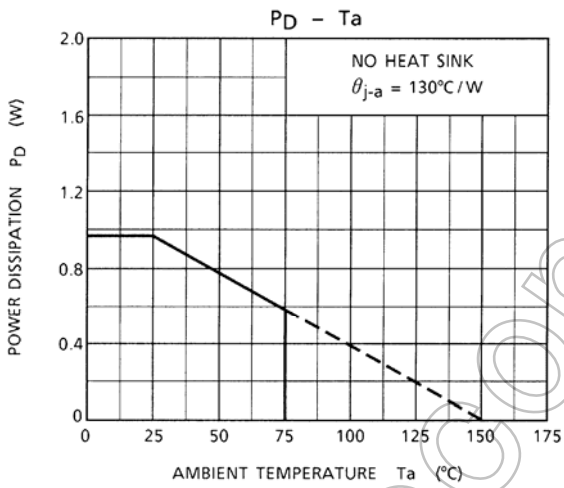

TA7291S/SG

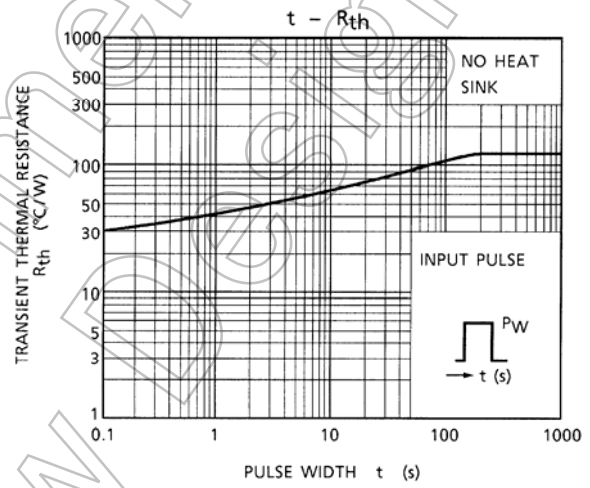

TA7291F/FG

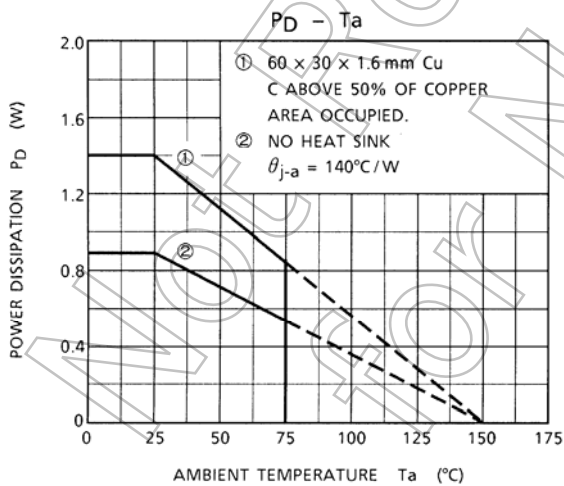

TA7291F/FG

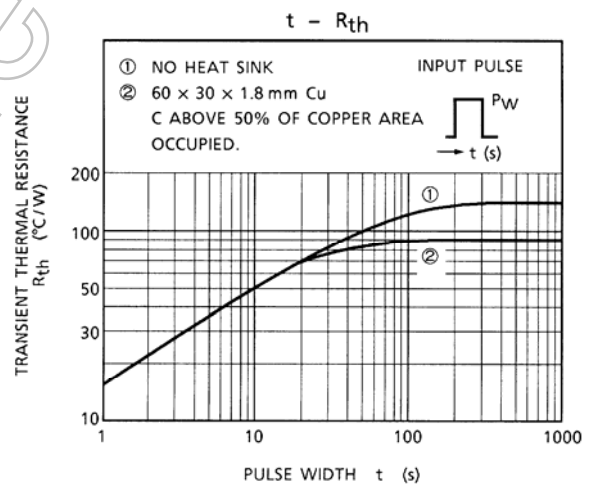

TA7291P

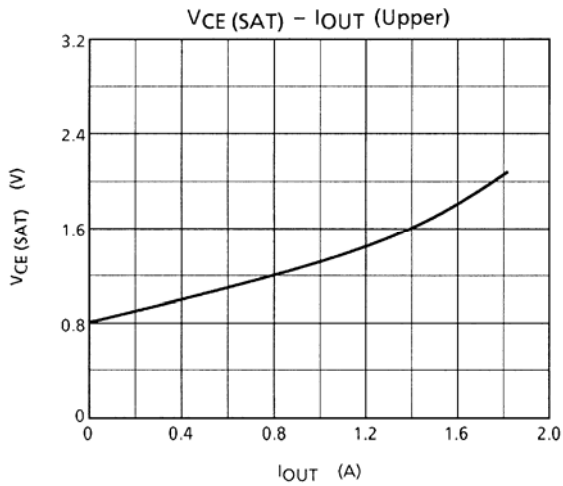

TA7291P

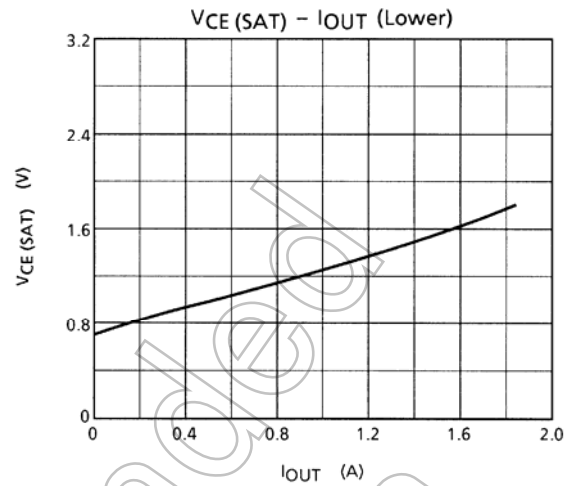

V_{ref} - V_{OUT} (H)

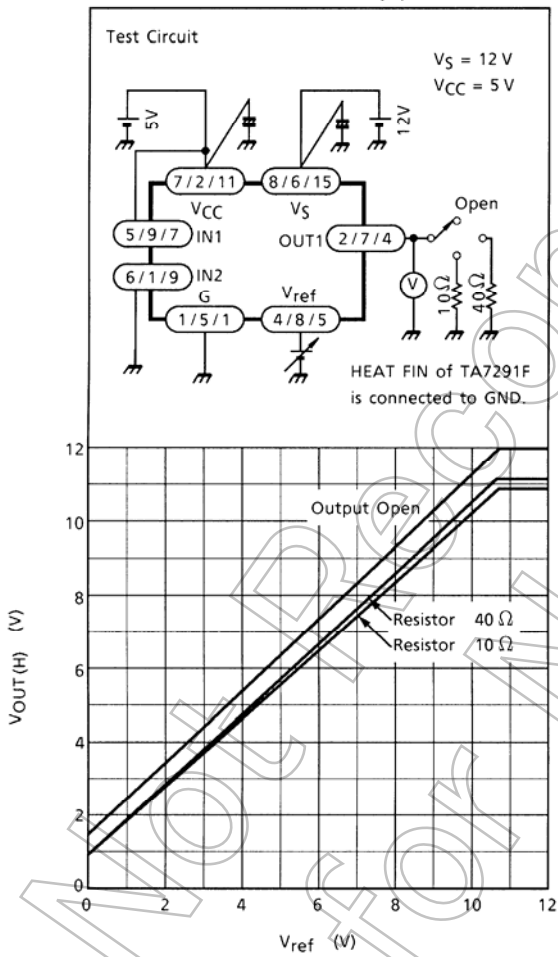

V_S - V_{OUT} (H)

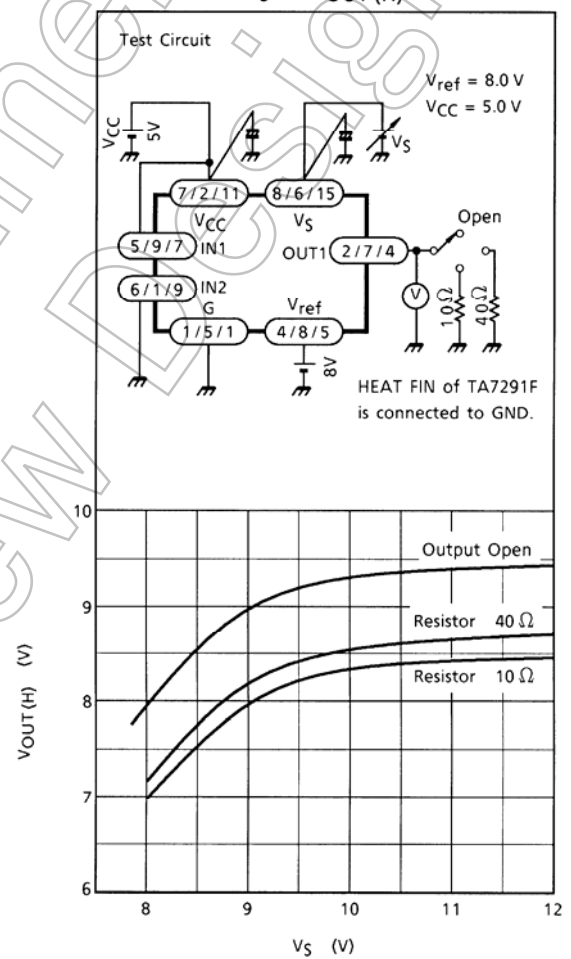

NOTES

Input circuit

Input Terminals of pin (5) and (6) (TA7291P) are all high active type and have a hysteresis of 0.7 V (typ.), 3 μ A (typ.) of source mode input current is required.

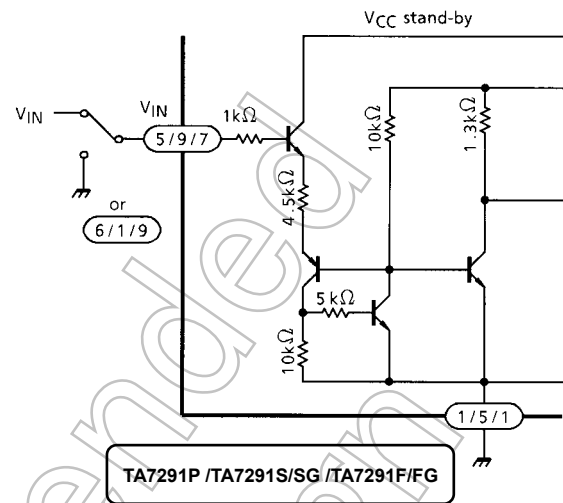

Output circuit

Output voltage is controlled by V_{ref} voltage.
Relationship between V_{OUT} and V_{ref} is

$$V_{OUT} = V_{BE} (\approx 0.7) + V_{ref}$$

V_{ref} terminal required to connect to V_S terminal for stable operation in case of no requirement of V_{OUT} control.

$$V_{ref} \leq V_S$$

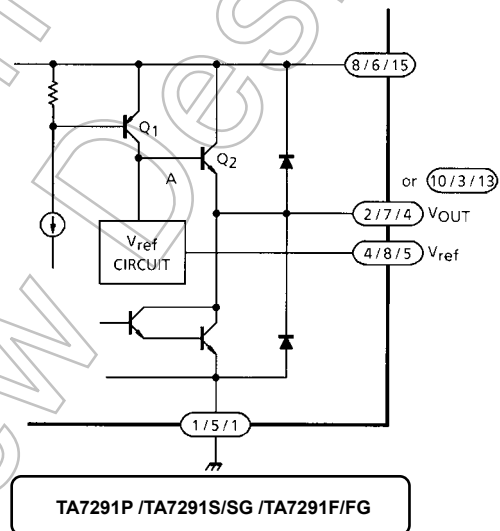

PACKAGE DIMENSIONS

HSIP10-P-2.54

Unit: mm

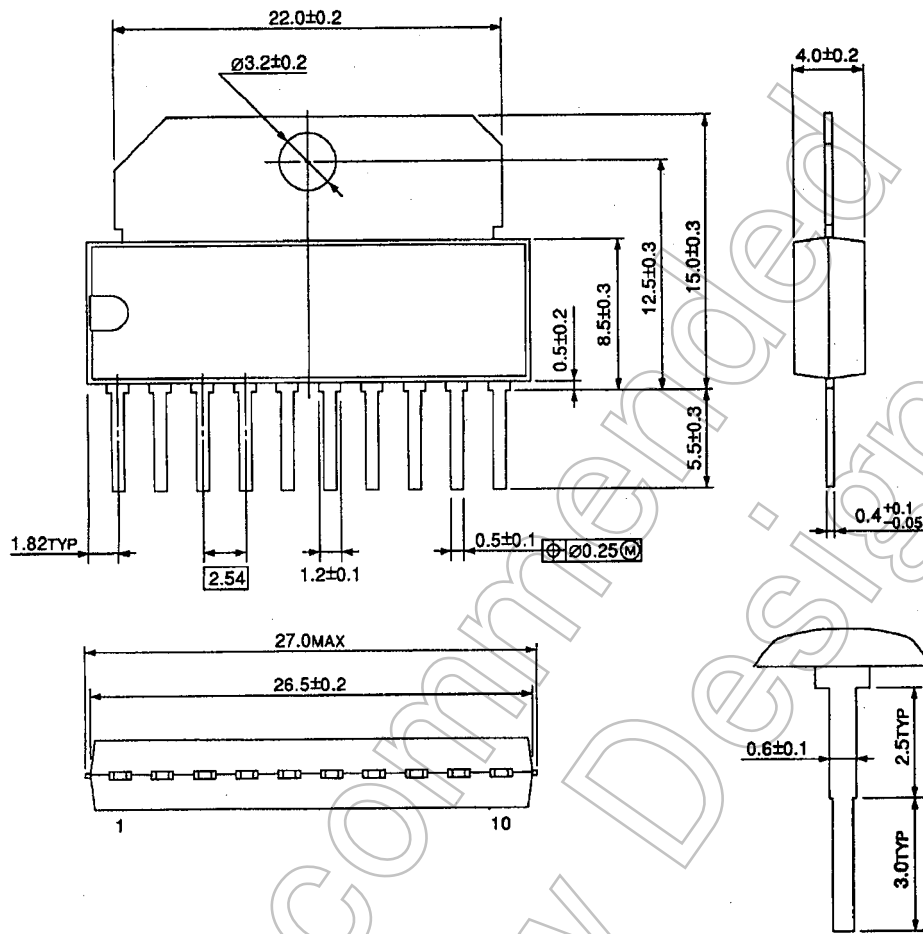

Weight: 2.47 g (Typ.)

Not Recommended for New Design

PACKAGE DIMENSIONS

SIP9-P-2.54A

Unit: mm

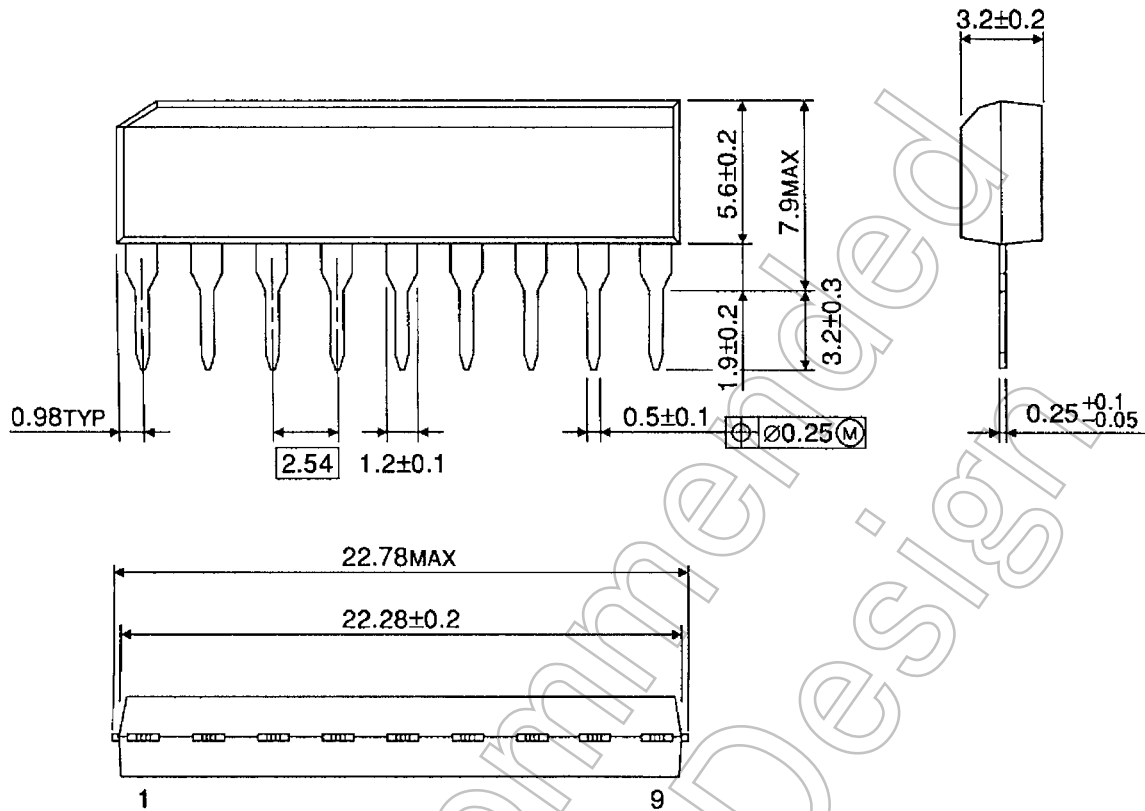

Weight: 0.92 g (Typ.)

Not Recommended for New Design

Notes on Contents

1. Block Diagrams

Some of the functional blocks, circuits, or constants in the block diagram may be omitted or simplified for explanatory purposes.

2. Equivalent Circuits

The equivalent circuit diagrams may be simplified or some parts of them may be omitted for explanatory purposes.

3. Timing Charts

Timing charts may be simplified for explanatory purposes.

4. Application Circuits

The application circuits shown in this document are provided for reference purposes only. Thorough evaluation is required, especially at the mass production design stage.

Toshiba does not grant any license to any industrial property rights by providing these examples of application circuits.

5. Test Circuits

Components in the test circuits are used only to obtain and confirm the device characteristics. These components and circuits are not guaranteed to prevent malfunction or failure from occurring in the application equipment.

IC Usage Considerations

Notes on handling of ICs

- [1] The absolute maximum ratings of a semiconductor device are a set of ratings that must not be exceeded, even for a moment. Do not exceed any of these ratings.
Exceeding the rating(s) may cause the device breakdown, damage or deterioration, and may result injury by explosion or combustion.
- [2] Use an appropriate power supply fuse to ensure that a large current does not continuously flow in case of over current and/or IC failure. The IC will fully break down when used under conditions that exceed its absolute maximum ratings, when the wiring is routed improperly or when an abnormal pulse noise occurs from the wiring or load, causing a large current to continuously flow and the breakdown can lead smoke or ignition. To minimize the effects of the flow of a large current in case of breakdown, appropriate settings, such as fuse capacity, fusing time and insertion circuit location, are required.
- [3] If your design includes an inductive load such as a motor coil, incorporate a protection circuit into the design to prevent device malfunction or breakdown caused by the current resulting from the inrush current at power ON or the negative current resulting from the back electromotive force at power OFF. IC breakdown may cause injury, smoke or ignition.
Use a stable power supply with ICs with built-in protection functions. If the power supply is unstable, the protection function may not operate, causing IC breakdown. IC breakdown may cause injury, smoke or ignition.
- [4] Do not insert devices in the wrong orientation or incorrectly.
Make sure that the positive and negative terminals of power supplies are connected properly. Otherwise, the current or power consumption may exceed the absolute maximum rating, and exceeding the rating(s) may cause the device breakdown, damage or deterioration, and may result injury by explosion or combustion.
In addition, do not use any device that is applied the current with inserting in the wrong orientation or incorrectly even just one time.

Points to remember on handling of ICs**(1) Over current Protection Circuit**

Over current protection circuits (referred to as current limiter circuits) do not necessarily protect ICs under all circumstances. If the Over current protection circuits operate against the over current, clear the over current status immediately.

Depending on the method of use and usage conditions, such as exceeding absolute maximum ratings can cause the over current protection circuit to not operate properly or IC breakdown before operation. In addition, depending on the method of use and usage conditions, if over current continues to flow for a long time after operation, the IC may generate heat resulting in breakdown.

(2) Thermal Shutdown Circuit

Thermal shutdown circuits do not necessarily protect ICs under all circumstances. If the thermal shutdown circuits operate against the over temperature, clear the heat generation status immediately.

Depending on the method of use and usage conditions, such as exceeding absolute maximum ratings can cause the thermal shutdown circuit to not operate properly or IC breakdown before operation.

(3) Heat Radiation Design

In using an IC with large current flow such as power amp, regulator or driver, please design the device so that heat is appropriately radiated, not to exceed the specified junction temperature (T_j) at any time and condition. These ICs generate heat even during normal use. An inadequate IC heat radiation design can lead to decrease in IC life, deterioration of IC characteristics or IC breakdown. In addition, please design the device taking into consideration the effect of IC heat radiation with peripheral components.

(4) Back-EMF

When a motor rotates in the reverse direction, stops or slows down abruptly, a current flow back to the motor's power supply due to the effect of back-EMF. If the current sink capability of the power supply is small, the device's motor power supply and output pins might be exposed to conditions beyond maximum ratings. To avoid this problem, take the effect of back-EMF into consideration in system design.

Not Recommended for New Design

RESTRICTIONS ON PRODUCT USE

070122EBA_R6

- The information contained herein is subject to change without notice. 021023_D
- TOSHIBA is continually working to improve the quality and reliability of its products. Nevertheless, semiconductor devices in general can malfunction or fail due to their inherent electrical sensitivity and vulnerability to physical stress. It is the responsibility of the buyer, when utilizing TOSHIBA products, to comply with the standards of safety in making a safe design for the entire system, and to avoid situations in which a malfunction or failure of such TOSHIBA products could cause loss of human life, bodily injury or damage to property.
In developing your designs, please ensure that TOSHIBA products are used within specified operating ranges as set forth in the most recent TOSHIBA products specifications. Also, please keep in mind the precautions and conditions set forth in the "Handling Guide for Semiconductor Devices," or "TOSHIBA Semiconductor Reliability Handbook" etc. 021023_A
- The TOSHIBA products listed in this document are intended for usage in general electronics applications (computer, personal equipment, office equipment, measuring equipment, industrial robotics, domestic appliances, etc.). These TOSHIBA products are neither intended nor warranted for usage in equipment that requires extraordinarily high quality and/or reliability or a malfunction or failure of which may cause loss of human life or bodily injury ("Unintended Usage"). Unintended Usage include atomic energy control instruments, airplane or spaceship instruments, transportation instruments, traffic signal instruments, combustion control instruments, medical instruments, all types of safety devices, etc. Unintended Usage of TOSHIBA products listed in this document shall be made at the customer's own risk. 021023_B
- The products described in this document shall not be used or embedded to any downstream products of which manufacture, use and/or sale are prohibited under any applicable laws and regulations. 060106_Q
- The information contained herein is presented only as a guide for the applications of our products. No responsibility is assumed by TOSHIBA for any infringements of patents or other rights of the third parties which may result from its use. No license is granted by implication or otherwise under any patents or other rights of TOSHIBA or the third parties. 070122_C
- Please use this product in compliance with all applicable laws and regulations that regulate the inclusion or use of controlled substances.
Toshiba assumes no liability for damage or losses occurring as a result of noncompliance with applicable laws and regulations. 060819_AF
- The products described in this document are subject to foreign exchange and foreign trade control laws. 060925_E

Looking for pricing, stock, or lifecycle information?

Click below to explore more details on WIN SOURCE:

- ⊖ [View TA7291FG on WIN SOURCE](#)
- ⊖ [Toshiba Semiconductor and Storage Information](#)

Optimize Your Supply Chain with WIN SOURCE Solutions

- ✓ Global Sourcing Solution
- ✓ Obsolete Management
- ✓ Cost Control Management
- ✓ Shortage Management
- ✓ Alternative Solution
- ✓ Excess Inventory Management