



**THE DATASHEET OF  
74SSTUB32868ZRHR**



## 28-BIT TO 56-BIT REGISTERED BUFFER WITH ADDRESS-PARITY TEST

### FEATURES

- Member of the Texas Instruments Widebus+™ Family
- Pinout Optimizes DDR2 DIMM PCB Layout
- 1-to-2 Outputs Supports Stacked DDR2 DIMMs
- One Device Per DIMM Required
- Chip-Select Inputs Gate the Data Outputs from Changing State and Minimizes System Power Consumption
- Output Edge-Control Circuitry Minimizes Switching Noise in an Unterminated Line
- Supports SSTL\_18 Data Inputs
- Differential Clock (CLK and  $\overline{\text{CLK}}$ ) Inputs

- Supports LVCMOS Switching Levels on the Chip-Select Gate-Enable, Control, and  $\overline{\text{RESET}}$  Inputs
- Checks Parity on DIMM-Independent Data Inputs
- Supports Industrial Temperature Range (-40°C to 85°C)
- $\overline{\text{RESET}}$  Input Disables Differential Input Receivers, Resets All Registers, and Forces All Outputs Low, Except QERR

### APPLICATIONS

- DDR2 registered DIMM

### DESCRIPTION

This 28-bit 1:2 configurable registered buffer is designed for 1.7-V to 1.9-V  $V_{CC}$  operation. One device per DIMM is required to drive up to 18 SDRAM loads or two devices per DIMM are required to drive up to 36 SDRAM loads.

All inputs are SSTL\_18, except the chip-select gate-enable (CSGEN), control (C), and reset ( $\overline{\text{RESET}}$ ) inputs, which are LVCMOS. All outputs are edge-controlled circuits optimized for unterminated DIMM loads, and meet SSTL\_18 specifications, except the open-drain error (QERR) output.

The 74SSTUB32868 operates from a differential clock (CLK and  $\overline{\text{CLK}}$ ). Data are registered at the crossing of CLK going high and  $\overline{\text{CLK}}$  going low.

The 74SSTUB32868 accepts a parity bit from the memory controller on the parity bit (PAR\_IN) input, compares it with the data received on the DIMM-independent D-inputs (D1–D5, D7, D9–D12, D17–D28 when C = 0; or D1–D12, D17–D20, D22, D24–D28 when C = 1) and indicates whether a parity error has occurred on the open-drain QERR pin (active low). The convention is even parity, i.e., valid parity is defined as an even number of ones across the DIMM-independent data inputs combined with the parity input bit. To calculate parity, all DIMM-independent D-inputs must be tied to a known logic state.

The 74SSTUB32868 includes a parity checking function. Parity, which arrives one cycle after the data input to which it applies, is checked on the PAR\_IN input of the device. Two clock cycles after the data are registered, the corresponding QERR signal is generated.

### ORDERING INFORMATION

$T_A$	PACKAGE <sup>(1)</sup>		ORDERABLE PART NUMBER	TOP-SIDE MARKING
-40°C to 85°C	TFBGA-ZRH	Tape and Reel	74SSTUB32868ZRHR	SB868

(1) For the most current package and ordering information, see the Package Option Addendum at the end of this document, or see the TI website at [www.ti.com](http://www.ti.com).



Please be aware that an important notice concerning availability, standard warranty, and use in critical applications of Texas Instruments semiconductor products and disclaimers thereto appears at the end of this data sheet.

Widebus+ is a trademark of Texas Instruments.



These devices have limited built-in ESD protection. The leads should be shorted together or the device placed in conductive foam during storage or handling to prevent electrostatic damage to the MOS gates.

## DESCRIPTION (CONTINUED)

If an error occurs and the  $\overline{QERR}$  output is driven low, it stays latched low for a minimum of two clock cycles or until  $\overline{RESET}$  is driven low. If two or more consecutive parity errors occur, the  $\overline{QERR}$  output is driven low and latched low for a clock duration equal to the parity error duration or until  $\overline{RESET}$  is driven low. If a parity error occurs on the clock cycle before the device enters the low-power mode (LPM) and the  $\overline{QERR}$  output is driven low, it stays latched low for the LPM duration plus two clock cycles or until  $\overline{RESET}$  is driven low. The DIMM-dependent signals ( $\overline{DCKE0}$ ,  $\overline{DCKE1}$ ,  $\overline{DODT0}$ ,  $\overline{DODT1}$ ,  $\overline{DCS0}$  and  $\overline{DCS1}$ ) are not included in the parity check computation.

The C input controls the pinout configuration from register-A configuration (when low) to register-B configuration (when high). The C input should not be switched during normal operation. It should be hard-wired to a valid low or high level to configure the register in the desired mode.

In the DDR2 RDIMM application,  $\overline{RESET}$  is specified to be completely asynchronous with respect to CLK and  $\overline{CLK}$ . Therefore, no timing relationship can be ensured between the two. When entering reset, the register is cleared and the data outputs is driven low quickly, relative to the time to disable the differential input receivers. However, when coming out of reset, the register becomes active quickly, relative to the time to enable the differential input receivers. As long as the data inputs are low, and the clock is stable during the time from the low-to-high transition of  $\overline{RESET}$  until the input receivers are fully enabled, the design of the 74SSTUB32868 must ensure that the outputs remain low, thus ensuring no glitches on the output.

To ensure defined outputs from the register before a stable clock has been supplied,  $\overline{RESET}$  must be held in the low state during power up.

The device supports low-power standby operation. When  $\overline{RESET}$  is low, the differential input receivers are disabled, and undriven (floating) data, clock, and reference voltage ( $V_{REF}$ ) inputs are allowed. In addition, when  $\overline{RESET}$  is low, all registers are reset and all outputs are forced low except  $\overline{QERR}$ . The LVCMOS  $\overline{RESET}$  and C inputs always must be held at a valid logic high or low level.

The device also supports low-power active operation by monitoring both system chip select ( $\overline{DCS0}$  and  $\overline{DCS1}$ ) and CSGEN inputs and will gate the Qn outputs from changing states when CSGEN,  $\overline{DCS0}$ , and  $\overline{DCS1}$  inputs are high. If CSGEN,  $\overline{DCS0}$  or  $\overline{DCS1}$  input is low, the Qn outputs function normally. Also, if both  $\overline{DCS0}$  and  $\overline{DCS1}$  inputs are high, the device will gate the  $\overline{QERR}$  output from changing states. If either  $\overline{DCS0}$  or  $\overline{DCS1}$  is low, the  $\overline{QERR}$  output functions normally. The  $\overline{RESET}$  input has priority over the  $\overline{DCS0}$  and  $\overline{DCS1}$  control and when driven low forces the Qn outputs low, and the  $\overline{QERR}$  output high. If the chip-select control functionality is not desired, then the CSGEN input can be hard-wired to ground, in which case, the setup-time requirement for  $\overline{DCS0}$  and  $\overline{DCS1}$  would be the same as for the other D data inputs. To control the low-power mode with  $\overline{DCS0}$  and  $\overline{DCS1}$  only, then the CSGEN input should be pulled up to  $V_{CC}$  through a pullup resistor.

The two  $V_{REF}$  pins (A5 and AB5) are connected together internally by approximately 150  $\Omega$ . However, it is necessary to connect only one of the two  $V_{REF}$  pins to the external  $V_{REF}$  power supply. An unused  $V_{REF}$  pin should be terminated with a  $V_{REF}$  coupling capacitor.

## ABSOLUTE MAXIMUM RATINGS

 over operating free-air temperature range (unless otherwise noted)<sup>(1)</sup>

		VALUE	UNIT
V <sub>CC</sub>	Supply voltage range	–0.5 to 2.5	V
V <sub>I</sub>	Input voltage range (see notes <sup>(2)</sup> and <sup>(3)</sup> )	–0.5 to V <sub>CC</sub> + 0.5	V
V <sub>O</sub>	Output voltage range (see notes <sup>(2)</sup> and <sup>(3)</sup> )	–0.5 to V <sub>CC</sub> + 0.5	V
I <sub>IK</sub>	Input clamp current (V <sub>I</sub> < 0, V <sub>I</sub> > V <sub>CC</sub> )	±50	mA
I <sub>OK</sub>	Output clamp current (V <sub>I</sub> < 0, V <sub>O</sub> > V <sub>CC</sub> )	±50	mA
I <sub>O</sub>	Continuous output current (V <sub>O</sub> = 0 to V <sub>CC</sub> )	±50	mA
I <sub>CC</sub>	Continuous current through each V <sub>CC</sub> or GND	±100	mA
R <sub>θJA</sub>	Thermal resistance, junction-to-ambient (see note <sup>(4)</sup> )	No airflow	46.8
		Airflow 200 ft/min	42.9
R <sub>θJC</sub>	Thermal resistance, junction-to-case (see note <sup>(4)</sup> )	No airflow	17.9
T <sub>stg</sub>	Storage temperature range	–65 to 150	°C

- (1) Stresses beyond those listed under *absolute maximum ratings* may cause permanent damage to the device. These are stress ratings only, and functional operation of the device at these or any other conditions beyond those indicated under *recommended operating conditions* is not implied. Exposure to absolute-maximum-rated conditions for extended periods may affect device reliability.
- (2) The input and output negative voltage ratings may be exceeded if the input and output clamp-current ratings are observed.
- (3) This value is limited to 2.5 V maximum.
- (4) The package thermal impedance is calculated in accordance with JESD 51-7.

## RECOMMENDED OPERATING CONDITIONS

 over operating free-air temperature range (unless otherwise noted)<sup>(1)</sup>

		MIN	NOM	MAX	UNIT	
<b>SUPPLY VOLTAGES, CURRENTS AND TEMPERATURE RANGE</b>						
V <sub>CC</sub>	Supply voltage	1.7			1.9	V
V <sub>REF</sub>	Reference voltage	0.49 x V <sub>CC</sub>	0.5 x V <sub>CC</sub>	0.51 x V <sub>CC</sub>	V	
V <sub>TT</sub>	Termination voltage	V <sub>REF</sub> - 40 mV	V <sub>REF</sub>	V <sub>REF</sub> + 40 mV	V	
V <sub>I</sub>	Input voltage	0			V <sub>CC</sub>	V
V <sub>IH</sub>	AC high-level input voltage	Data inputs, $\overline{\text{DCSn}}$ , PAR_IN	V <sub>REF</sub> + 250 mV		V	
V <sub>IL</sub>	AC low-level input voltage	Data inputs, $\overline{\text{DCSn}}$ , PAR_IN	V <sub>REF</sub> - 250 mV		V	
V <sub>IH</sub>	DC high-level input voltage	Data inputs, $\overline{\text{DCSn}}$ , PAR_IN	V <sub>REF</sub> + 125 mV		V	
V <sub>IL</sub>	DC low-level input voltage	Data inputs, $\overline{\text{DCSn}}$ , PAR_IN	V <sub>REF</sub> - 125 mV		V	
V <sub>IH</sub>	High-level input voltage	$\overline{\text{RESET}}$ , CSGEN, C	0.65 x V <sub>CC</sub>		V	
V <sub>IL</sub>	Low-level input voltage	$\overline{\text{RESET}}$ , CSGEN, C	0.35 x V <sub>CC</sub>		V	
V <sub>ICR</sub>	Common-mode input voltage range	CLK, $\overline{\text{CLK}}$	0.675		1.125	V
V <sub>I(PP)</sub>	Peak-to-peak input voltage	CLK, $\overline{\text{CLK}}$	0.6		V	
I <sub>OH</sub>	High-level output current	Q outputs			-8	mA
I <sub>OL</sub>	Low-level output current	Q outputs			8	mA
		$\overline{\text{QERR}}$ output	30			
T <sub>A</sub>	Operating free-air temperature	-40			85	°C

- (1) The  $\overline{\text{RESET}}$  and Cn inputs of the device must be held at valid logic voltage levels (not floating) to ensure proper device operation. The differential inputs must not be floating unless  $\overline{\text{RESET}}$  is low. See the TI application report, Implications of Slow or Floating CMOS Inputs, literature number [SCBA004](#).

## ELECTRICAL CHARACTERISTICS

over operating free-air temperature range (unless otherwise noted)

PARAMETER		TEST CONDITION	V <sub>CC</sub>	MIN	TYP <sup>(1)</sup>	MAX	UNIT
V <sub>OH</sub>	Q outputs	I <sub>OH</sub> = -100 μA	1.7 V to 1.9 V	V <sub>CC</sub> - 0.2			V
		I <sub>OH</sub> = -6 mA	1.7 V	1.2			
V <sub>OL</sub>	Q outputs	I <sub>OL</sub> = 100 μA	1.7 V to 1.9 V	0.2			V
		I <sub>OL</sub> = 6 mA	1.7 V	0.5			
	$\overline{\text{QERR}}$	I <sub>OL</sub> = 25 mA	1.7 V	0.5			
I <sub>I</sub>	PAR_IN	V <sub>I</sub> = GND	1.9 V	-5			μA
		V <sub>I</sub> = V <sub>CC</sub>		25			
	All other inputs <sup>(2)</sup>	V <sub>I</sub> = V <sub>CC</sub> or GND		±5			
I <sub>OZ</sub>	$\overline{\text{QERR}}$ outputs	V <sub>O</sub> = V <sub>CC</sub> or GND	1.9 V	±10			μA
I <sub>CC</sub>	Static standby <sup>(3)</sup>	$\overline{\text{RESET}}$ = GND	1.9 V	I <sub>O</sub> = 0	200 <sup>(3)</sup>		μA
	Static operating	$\overline{\text{RESET}}$ = V <sub>CC</sub> , V <sub>I</sub> = V <sub>IH(AC)</sub> or V <sub>IL(AC)</sub>			80		mA
I <sub>CC(D)</sub>	Dynamic operating – clock only	$\overline{\text{RESET}}$ = V <sub>CC</sub> , V <sub>I</sub> = V <sub>IH(AC)</sub> or V <sub>IL(AC)</sub> , CLK and CLK switching 50% duty cycle	1.8 V	I <sub>O</sub> = 0	64		μA/MHz
	Dynamic operating – per each data input	$\overline{\text{RESET}}$ = V <sub>CC</sub> , V <sub>I</sub> = V <sub>IH(AC)</sub> or V <sub>IL(AC)</sub> , CLK and CLK switching 50% duty cycle, One data input switching at one half clock frequency, 50% duty cycle			37		μA/clock MHz/ D inputs
I <sub>CC(DLP)</sub>	Chip-select-enabled low-power active mode – clock only	$\overline{\text{RESET}}$ = V <sub>CC</sub> , V <sub>I</sub> = V <sub>IH(AC)</sub> or V <sub>IL(AC)</sub> , CLK and CLK switching 50% duty cycle	1.8 V	I <sub>O</sub> = 0	68		μA/MHz
	Chip-select-enabled low-power active mode	$\overline{\text{RESET}}$ = V <sub>CC</sub> , V <sub>I</sub> = V <sub>IH(AC)</sub> or V <sub>IL(AC)</sub> , CLK and CLK switching 50% duty cycle, One data input switching at one half clock frequency, 50% duty cycle			2.7		μA/clock MHz/ D inputs
C <sub>I</sub>	Data inputs, DCSn, PAR_IN, CSGEN	V <sub>I</sub> = V <sub>REF</sub> ±250 mV	1.8 V	2		2.5	pF
	CLK, $\overline{\text{CLK}}$	V <sub>ICR</sub> = 0.9 V, V <sub>I(PP)</sub> = 600 mV		2		3	
	$\overline{\text{RESET}}$	V <sub>I</sub> = V <sub>CC</sub> or GND		4			

(1) All typical values are at V<sub>CC</sub> = 1.8 V, T<sub>A</sub> = 25°C.

(2) Each V<sub>REF</sub> pin (A5 or AB5) should be tested independently, with the other (untested) pin open.

(3) The maximum static standby current I<sub>CC</sub> is 100 μA if the device is exposed to commercial temperature range (0°C to 70°C) only. For industrial temperature range (-40°C to 85°C), the static I<sub>CC</sub> is 200 μA.

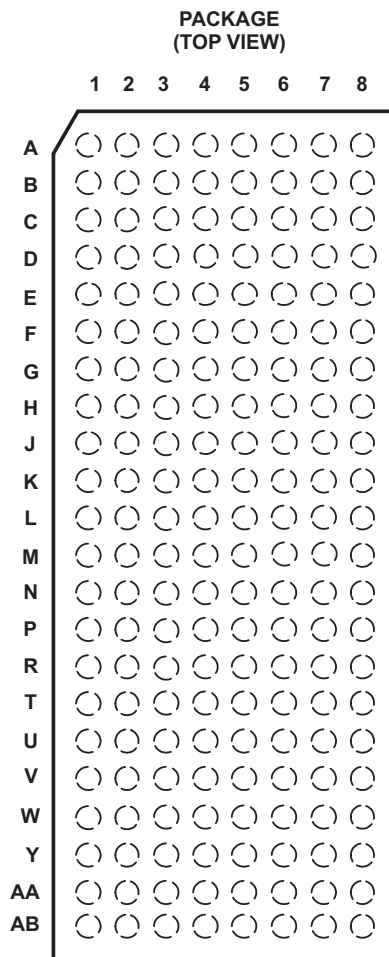

Terminal Assignment for Register-A (C = 0)

	1	2	3	4	5	6	7	8
A	D2	D1	C	GND	V <sub>REF</sub>	GND	Q1A	Q1B
B	D4	D3	V <sub>CC</sub>	V <sub>CC</sub>	V <sub>CC</sub>	V <sub>CC</sub>	Q2A	Q2B
C	D6 (DCKE1)	D5	GND	GND	GND	GND	Q3A	Q3B
D	D8 (DCKE0)	D7	V <sub>CC</sub>	V <sub>CC</sub>	V <sub>CC</sub>	V <sub>CC</sub>	Q4A	Q4B
E	D9	Q6A (QCKE1A)	GND	GND	GND	GND	Q5A	Q5B
F	D10	Q8A (QCKE0A)	V <sub>CC</sub>	V <sub>CC</sub>	V <sub>CC</sub>	V <sub>CC</sub>	Q7A	Q6B (QCKE1B)
G	D11	Q10A	GND	GND	GND	GND	Q9A	Q7B
H	D12	Q12A	V <sub>CC</sub>	V <sub>CC</sub>	V <sub>CC</sub>	V <sub>CC</sub>	Q11A	Q8B (QCKE0B)
J	D13 (DCS1)	Q13A (QCS1A)	GND	GND	GND	GND	Q10B	Q9B
K	D14 (DCS0)	Q14A (QCS0A)	V <sub>CC</sub>	V <sub>CC</sub>	V <sub>CC</sub>	V <sub>CC</sub>	Q12B	Q11B
L	CLK	CSGEN	PAR_IN	GND	GND	GND	Q14B (QCS0B)	Q13B (QCS1B)
M	$\overline{\text{CLK}}$	$\overline{\text{RESET}}$	$\overline{\text{QERR}}$	V <sub>CC</sub>	V <sub>CC</sub>	V <sub>CC</sub>	Q15B (QODT0B)	Q16B (QODT1B)
N	D15 (DODT0)	Q15A (QODT0A)	GND	GND	GND	GND	Q17B	Q18B
P	D16 (DODT1)	Q16A (QODT1A)	V <sub>CC</sub>	V <sub>CC</sub>	V <sub>CC</sub>	V <sub>CC</sub>	Q19B	Q20B
R	D17	Q17A	GND	GND	GND	GND	Q18A	Q21B
T	D18	Q19A	V <sub>CC</sub>	V <sub>CC</sub>	V <sub>CC</sub>	V <sub>CC</sub>	Q20A	Q22B
U	D19	Q21A	GND	GND	GND	GND	Q22A	Q23B
V	D20	Q23A	V <sub>CC</sub>	V <sub>CC</sub>	V <sub>CC</sub>	V <sub>CC</sub>	Q24A	Q24B
W	D21	D22	GND	GND	GND	GND	Q25A	Q25B
Y	D23	D24	V <sub>CC</sub>	V <sub>CC</sub>	V <sub>CC</sub>	V <sub>CC</sub>	Q26A	Q26B
AA	D25	D26	GND	GND	GND	GND	Q27A	Q27B
AB	D27	D28	NC	V <sub>CC</sub>	V <sub>REF</sub>	V <sub>CC</sub>	Q28A	Q28B

- A. Each pin name in parentheses indicates the DDR2 DIMM signal name.
- B. NC - No internal connection.

Logic Diagram for Register-A Configuration (Positive Logic); C = 0

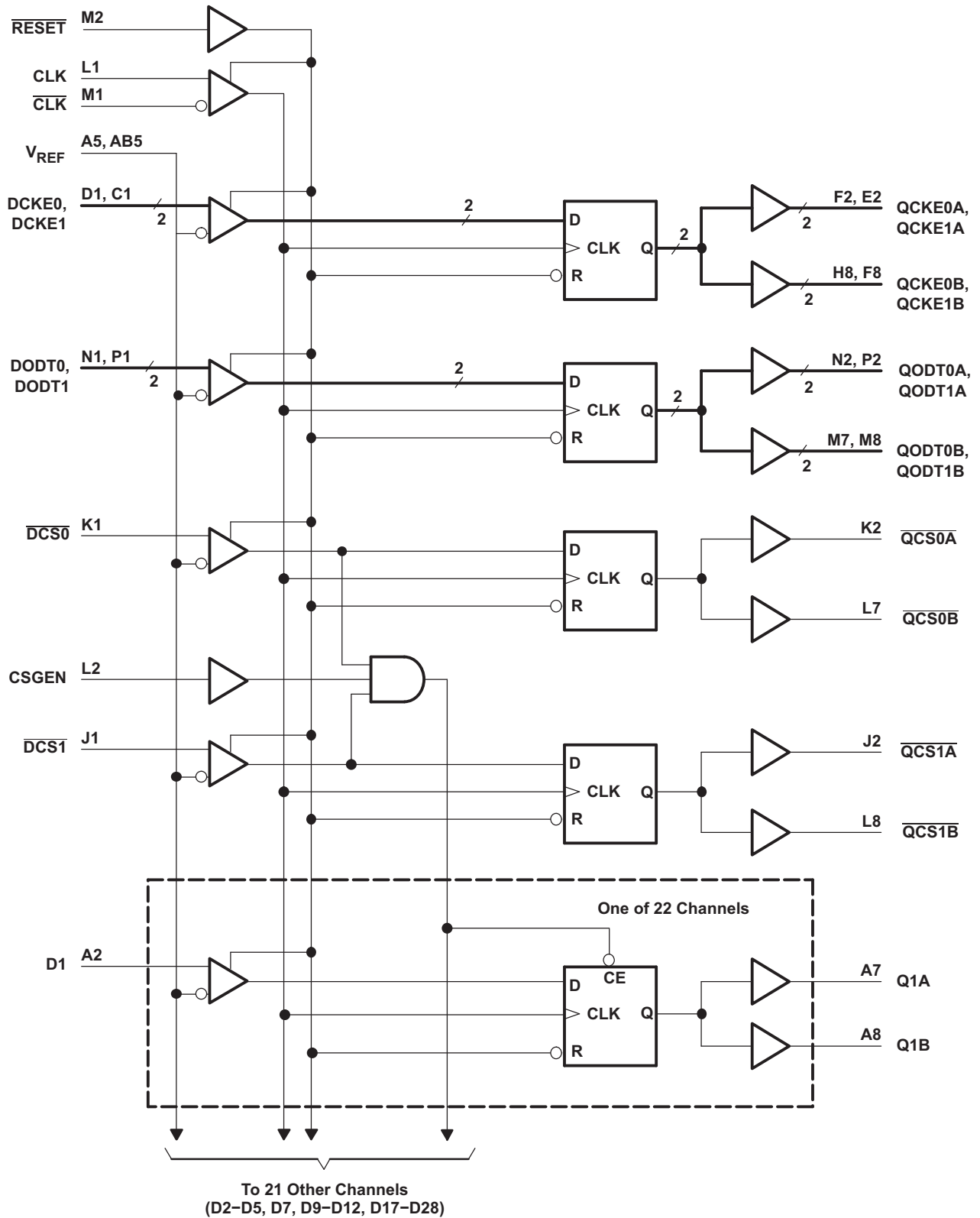

Parity Logic Diagram for Register-A Configuration (Positive Logic); C = 0

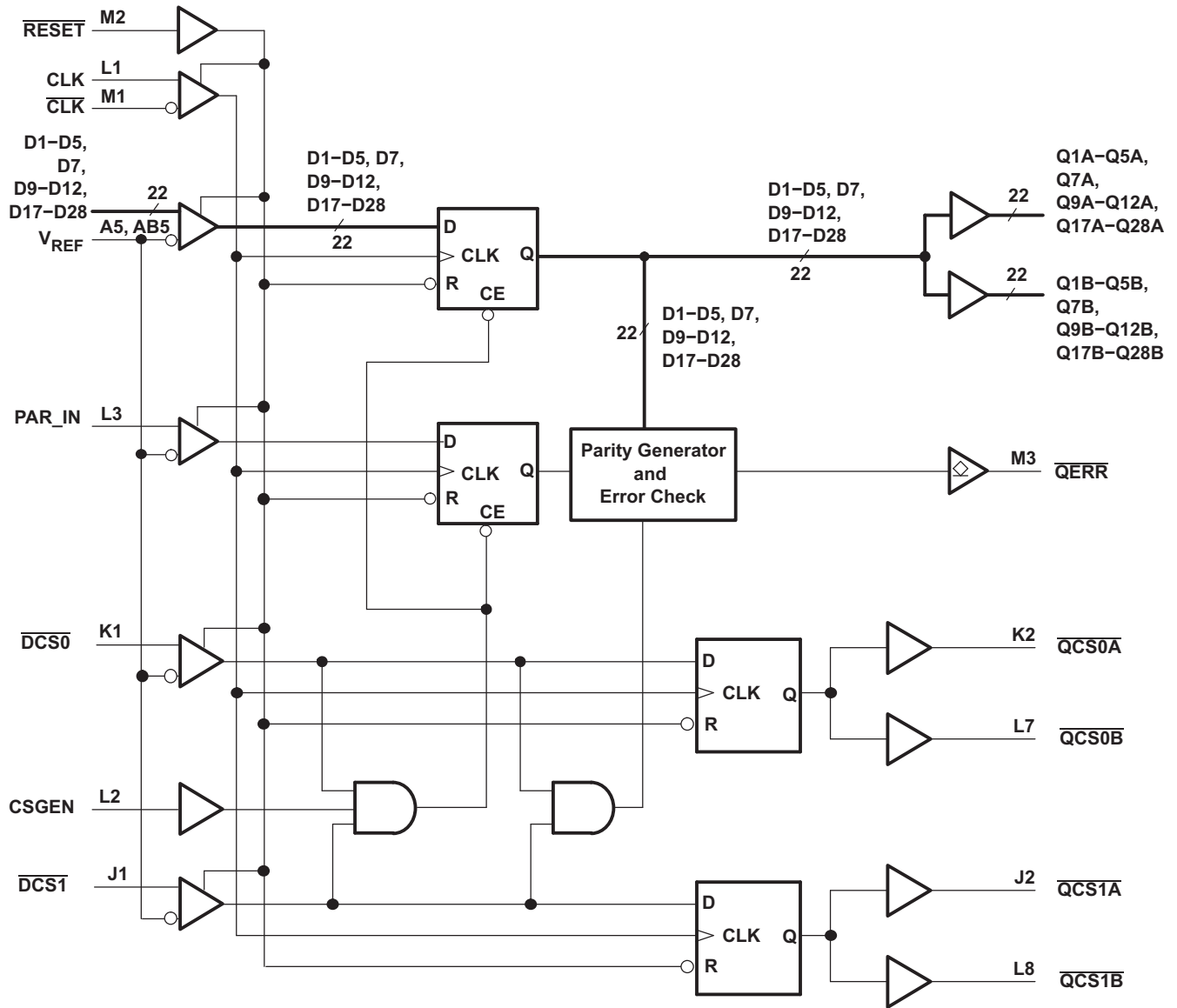

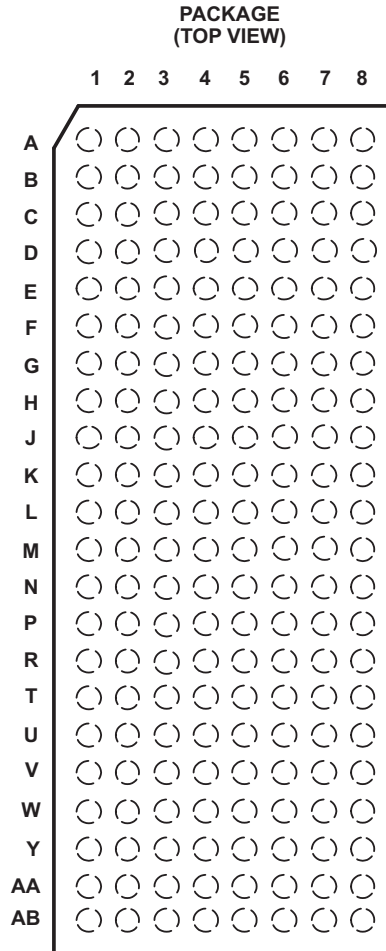

**Terminal Assignment for Register-B (C = 1)**

	1	2	3	4	5	6	7	8
A	D2	D1	C	GND	V <sub>REF</sub>	GND	Q1A	Q1B
B	D4	D3	V <sub>CC</sub>	V <sub>CC</sub>	V <sub>CC</sub>	V <sub>CC</sub>	Q2A	Q2B
C	D6	D5	GND	GND	GND	GND	Q3A	Q3B
D	D8	D7	V <sub>CC</sub>	V <sub>CC</sub>	V <sub>CC</sub>	V <sub>CC</sub>	Q4A	Q4B
E	D9	Q6A	GND	GND	GND	GND	Q5A	Q5B
F	D10	Q8A	V <sub>CC</sub>	V <sub>CC</sub>	V <sub>CC</sub>	V <sub>CC</sub>	Q7A	Q6B
G	D11	Q10A	GND	GND	GND	GND	Q9A	Q7B
H	D12	Q12A	V <sub>CC</sub>	V <sub>CC</sub>	V <sub>CC</sub>	V <sub>CC</sub>	Q11A	Q8B
J	D13 (DODT1)	Q13A (DODT1A)	GND	GND	GND	GND	Q10B	Q9B
K	D14 (DODT0)	Q14A (QODT0A)	V <sub>CC</sub>	V <sub>CC</sub>	V <sub>CC</sub>	V <sub>CC</sub>	Q12B	Q11B
L	CLK	CSGEN	PAR_IN	GND	GND	GND	Q14B (QODT0B)	Q13B (QODT1B)
M	CLK	RESET	QERR	V <sub>CC</sub>	V <sub>CC</sub>	V <sub>CC</sub>	Q15B (QCS0B)	Q16B (QCS1B)
N	D15 (DCS0)	Q15A (QCS0A)	GND	GND	GND	GND	Q17B	Q18B
P	D16 (DCS1)	Q16A (QCS1A)	V <sub>CC</sub>	V <sub>CC</sub>	V <sub>CC</sub>	V <sub>CC</sub>	Q19B	Q20B
R	D17	Q17A	GND	GND	GND	GND	Q18A	Q21B (QCKE0B)
T	D18	Q19A	V <sub>CC</sub>	V <sub>CC</sub>	V <sub>CC</sub>	V <sub>CC</sub>	Q20A	Q22B
U	D19	Q21A (QCKE0A)	GND	GND	GND	GND	Q22A	Q23B (QCKE1B)
V	D20	Q23A (QCKE1A)	V <sub>CC</sub>	V <sub>CC</sub>	V <sub>CC</sub>	V <sub>CC</sub>	Q24A	Q24B
W	D21 (DCKE0)	D22	GND	GND	GND	GND	Q25A	Q25B
Y	D23 (DCKE1)	D24	V <sub>CC</sub>	V <sub>CC</sub>	V <sub>CC</sub>	V <sub>CC</sub>	Q26A	Q26B
AA	D25	D26	GND	GND	GND	GND	Q27A	Q27B
AB	D27	D28	NC	V <sub>CC</sub>	V <sub>REF</sub>	V <sub>CC</sub>	Q28A	Q28B

Logic Diagram for Register-B Configuration (Positive Logic); C = 1

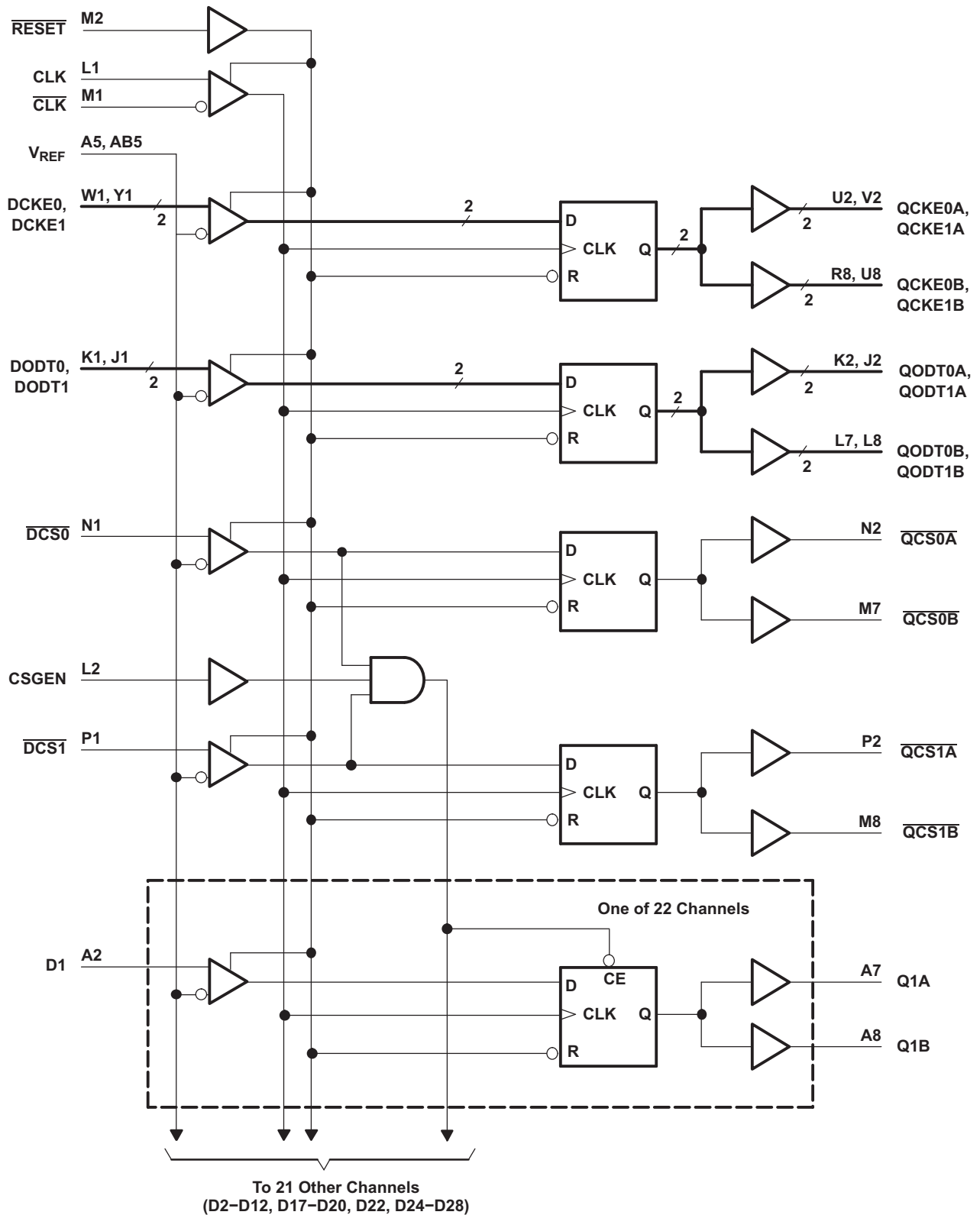

Parity Logic Diagram for Register-B Configuration (Positive Logic); C = 1

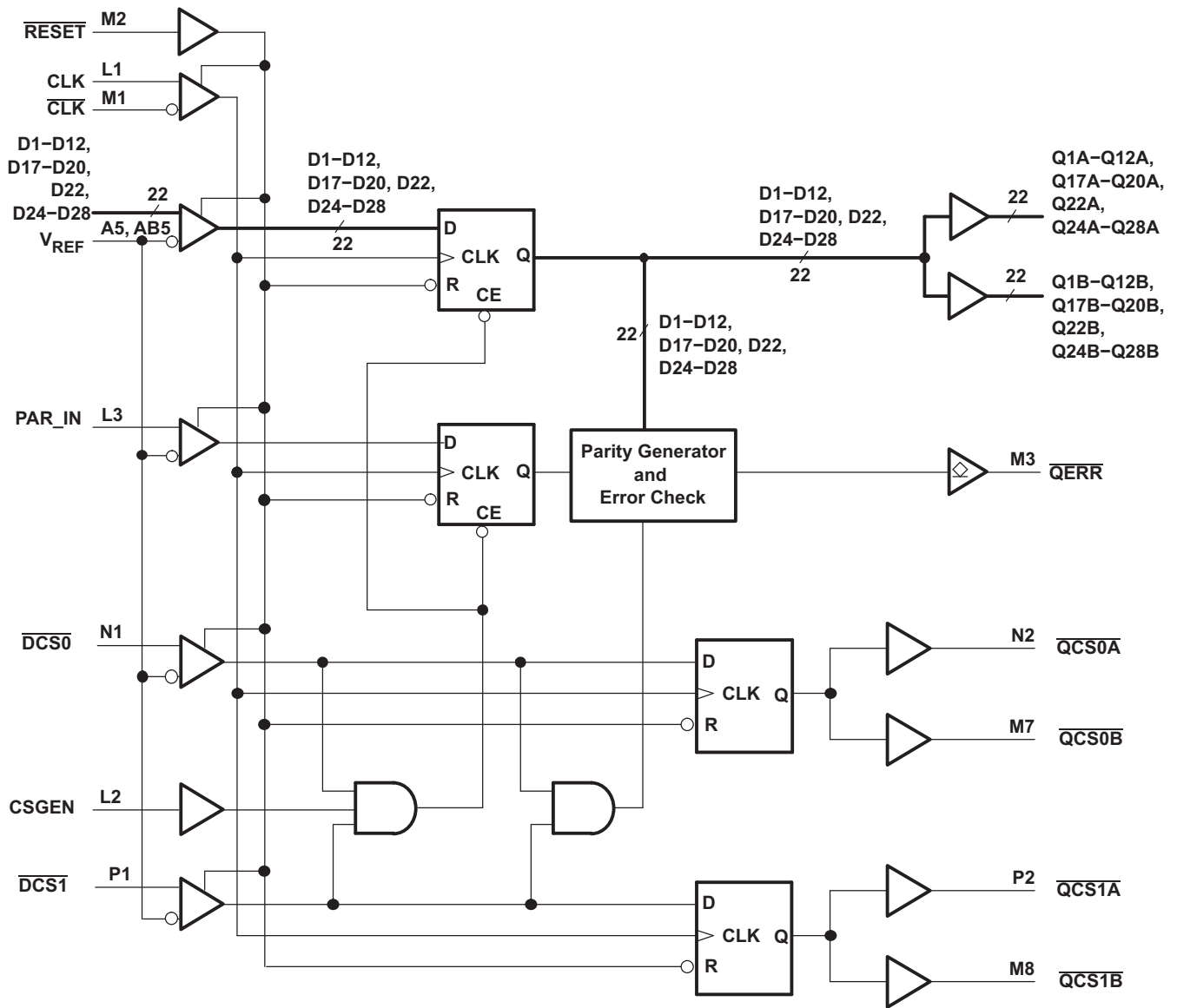

Timing Diagram for 74SSTUB32868 During Start-Up ( $\overline{\text{RESET}}$  Switches From L to H)

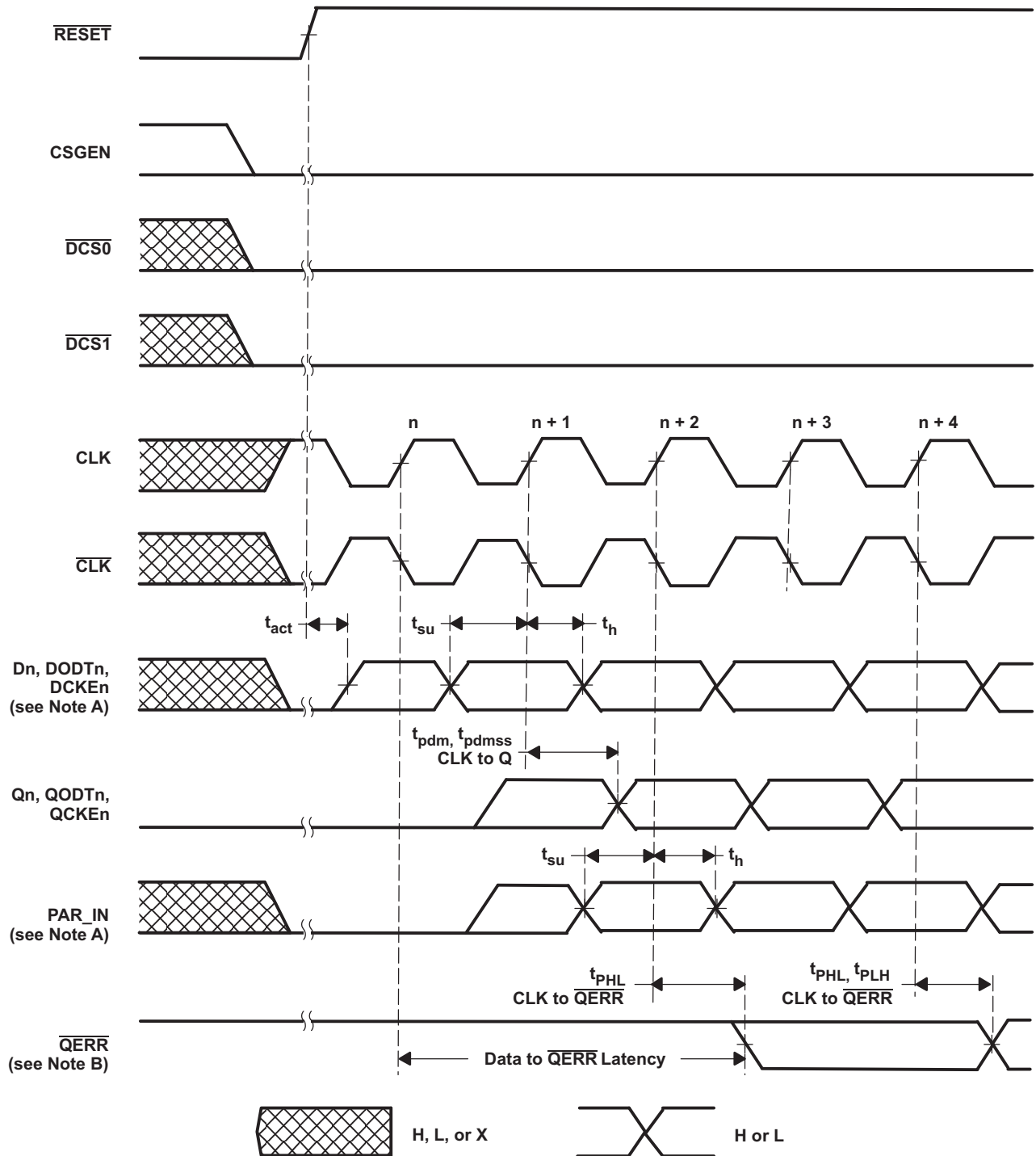

- A. After  $\overline{\text{RESET}}$  is switched from low to high, all data and  $\text{PAR\_IN}$  input signals must be set and held low for a minimum time of  $t_{\text{act}}$  max, to avoid a false error.
- B. If the data is clocked in on the n-clock pulse, the  $\overline{\text{QERR}}$  output signal is generated on the n + 2 clock pulse, and it is valid on the n + 3 clock pulse.

**Timing Diagram for 74SSTUB32868 During Normal Operation ( $\overline{\text{RESET}} = \text{H}$ )**

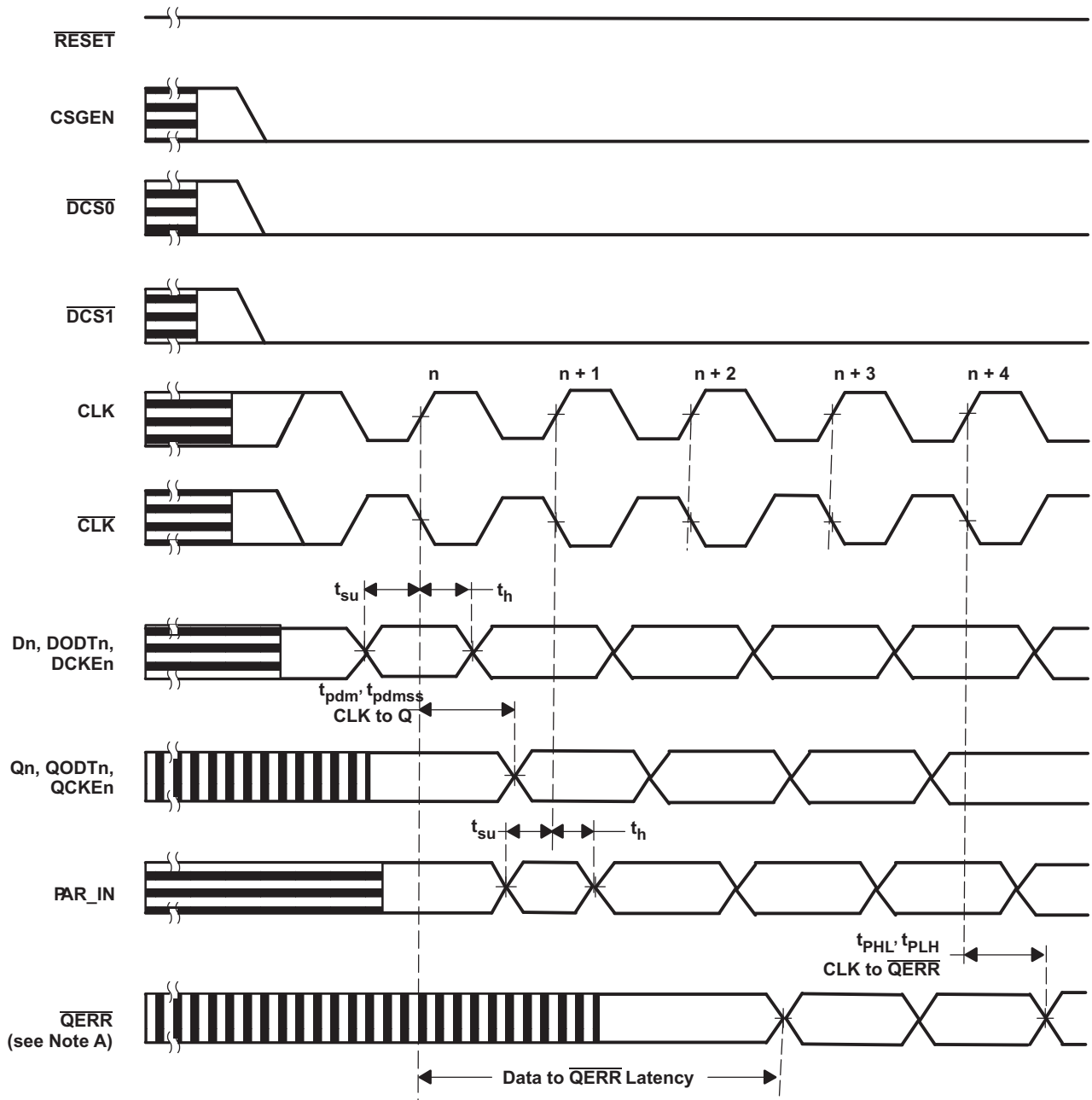

- A. If the data is clocked in on the n-clock pulse, the  $\overline{\text{QERR}}$  output signal is generated on the n + 2 clock pulse, and it is valid on the n + 3 clock pulse. If an error occurs and the  $\overline{\text{QERR}}$  output is driven low, it stays latched low for a minimum of two clock cycles or until  $\overline{\text{RESET}}$  is driven low.

Timing Diagram for 74SSTUB32868 During Shut-Down ( $\overline{\text{RESET}}$  Switches From H to L)

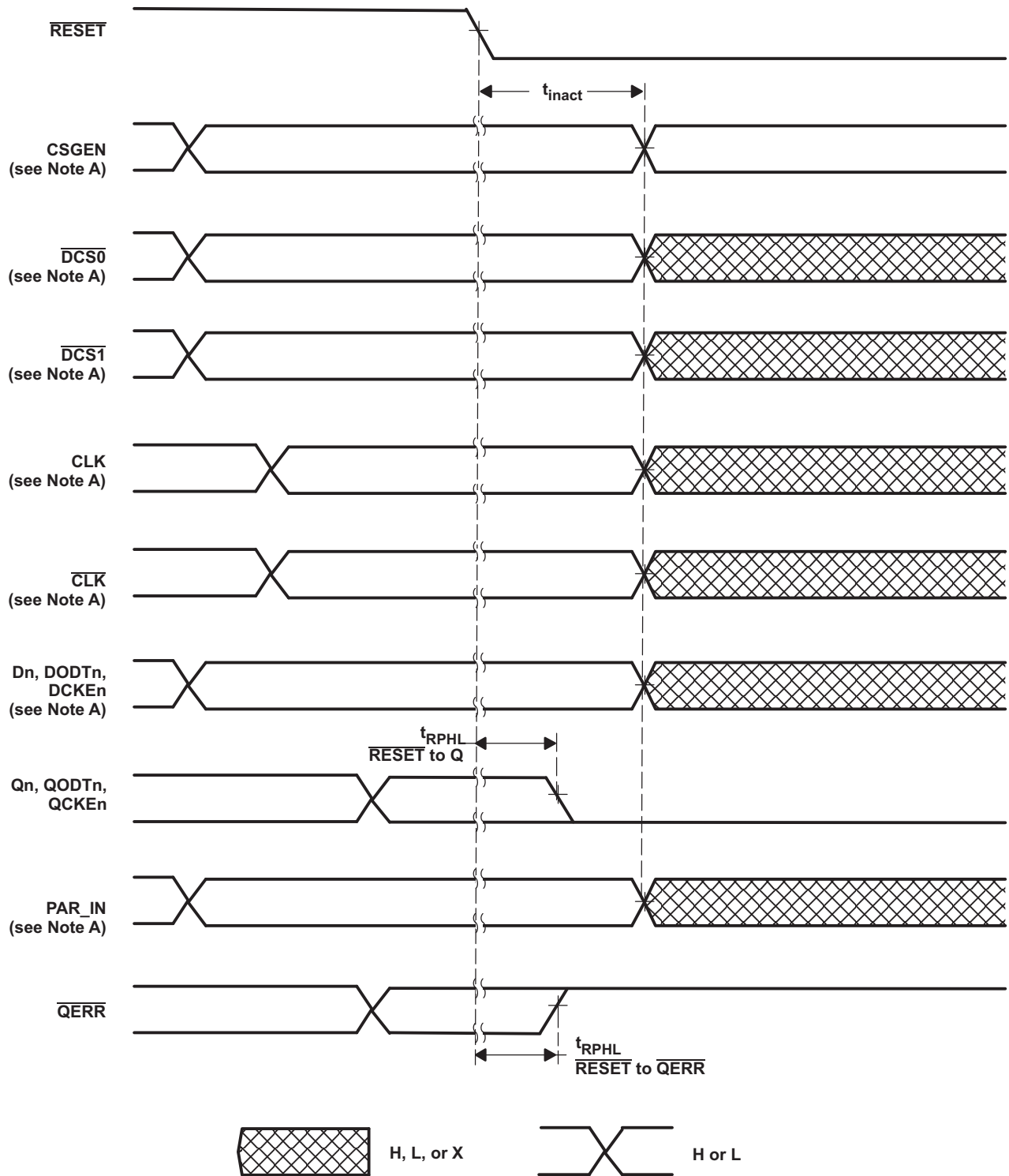

- A. After  $\overline{\text{RESET}}$  is switched from high to low, all data and clock input signals must be held at logic levels (not floating) for a minimum time of  $t_{\text{inact}}$  max, to avoid a false error.

### TERMINAL FUNCTIONS

TERMINAL NAME	DESCRIPTION	ELECTRICAL CHARACTERISTICS
GND	Ground	Ground input
V <sub>CC</sub>	Power supply voltage	1.8 V nominal
V <sub>REF</sub>	Input reference voltage	0.9 V nominal
CLK	Positive master clock input	Differential input
$\overline{\text{CLK}}$	Negative master clock input	Differential input
C	Configuration control input - Register A or Register B	LVC MOS input
$\overline{\text{RESET}}$	Asynchronous reset input – resets registers and disables V <sub>REF</sub> , data and clock differential-input receivers. When RESET is low, all the Q outputs are forced low and the QERR output is forced high.	LVC MOS input
CSGEN	Chip select gate enable – When high, D1–D28 <sup>(1)</sup> inputs are latched only when at least one chip select input is low during the rising edge of the clock. When low, the D1–D28 <sup>(1)</sup> inputs are latched and redriven on every rising edge of the clock.	LVC MOS input
D1–D28	Data input – clocked in on the crossing of the rising edge of CLK and the falling edge of CLK	SSTL <sub>18</sub> input
$\overline{\text{DCS0}}$ , $\overline{\text{DCS1}}$	Chip select inputs – These pins initiate DRAM address/command decodes, and as such at least one will be low when a valid address/command is present. The Register can be programmed to redrive all D inputs (CSGEN high) only when at least one chip select input is low. If CSGEN, $\overline{\text{DCS0}}$ , and $\overline{\text{DCS1}}$ inputs are high, D1–D28 <sup>(2)</sup> inputs will be disabled.	SSTL <sub>18</sub> input
DODT0, DODT1	The outputs of this register bit will not be suspended by the $\overline{\text{DCS0}}$ and $\overline{\text{DCS1}}$ control.	SSTL <sub>18</sub> input
DCKE0, DEKE1	The outputs of this register bit will not be suspended by the $\overline{\text{DCS0}}$ and $\overline{\text{DCS1}}$ control.	SSTL <sub>18</sub> input
PAR_IN	Parity input – arrives one clock cycle after the corresponding data input. Pulldown resistor of typical 150kΩ to GND.	SSTL <sub>18</sub> input with pulldown
Q1–Q28 <sup>(3)</sup>	Data outputs that are suspended by the $\overline{\text{DCS0}}$ and $\overline{\text{DCS1}}$ control.	1.8 V CMOS output
$\overline{\text{QCS0}}$ , $\overline{\text{QCS1}}$	Data output that will not be suspended by the $\overline{\text{DCS0}}$ and $\overline{\text{DCS1}}$ control.	1.8 V CMOS output
QODT0, QODT1	Data output that will not be suspended by the $\overline{\text{DCS0}}$ and $\overline{\text{DCS1}}$ control.	1.8 V CMOS output
QCKE0, QEKE1	Data output that will not be suspended by the $\overline{\text{DCS0}}$ and $\overline{\text{DCS1}}$ control.	1.8 V CMOS output
$\overline{\text{QERR}}$	Output error bit – generated two clock cycles after the corresponding data is registered.	Open-drain output
NC	No internal connection	

- (1) Data inputs = D1–D5, D7, D9–D12, D17–D28 when C = 0.  
Data inputs = D1–D12, D17–D20, D22, D24–D28 when C = 1.
- (2) Data inputs = D1–D5, D7, D9–D12, D17–D28 when C = 0.  
Data inputs = D1–D12, D17–D20, D22, D24–D28 when C = 1.
- (3) Data outputs = Q1–Q5, Q7, Q9–Q12, Q17–Q28 when C = 0.  
Data outputs = Q1–Q12, Q17–Q20, Q22, Q24–Q28 when C = 1.

**FUNCTION TABLE**

INPUTS							OUTPUTS			
RESET	DCS0	DCS1	CSGEN	CLK	CLK	dn, DODTn, DCKEn	Qn	QCS0	QCS1	QODT, QCKE
H	L	L	X	↑	↓	L	L	L	L	L
H	L	L	X	↑	↓	H	H	L	L	H
H	L	L	X	L or H	L or H	X	Q <sub>0</sub>	Q <sub>0</sub>	Q <sub>0</sub>	Q <sub>0</sub>
H	L	H	X	↑	↓	L	L	L	H	L
H	L	H	X	↑	↓	H	H	L	H	H
H	L	H	X	L or H	L or H	X	Q <sub>0</sub>	Q <sub>0</sub>	Q <sub>0</sub>	Q <sub>0</sub>
H	H	L	X	↑	↓	L	L	H	L	L
H	H	L	X	↑	↓	H	H	H	L	H
H	H	L	X	L or H	L or H	X	Q <sub>0</sub>	Q <sub>0</sub>	Q <sub>0</sub>	Q <sub>0</sub>
H	H	H	L	↑	↓	L	L	H	H	L
H	H	H	L	↑	↓	H	H	H	H	H
H	H	H	L	L or H	L or H	X	Q <sub>0</sub>	Q <sub>0</sub>	Q <sub>0</sub>	Q <sub>0</sub>
H	H	H	H	↑	↓	L	Q <sub>0</sub>	H	H	L
H	H	H	H	↑	↓	H	Q <sub>0</sub>	H	H	H
H	H	H	H	L or H	L or H	X	Q <sub>0</sub>	Q <sub>0</sub>	Q <sub>0</sub>	Q <sub>0</sub>
L	X or floating	X or floating	X or floating	X or floating	X or floating	L	L	L	L	L

**PARITY AND STANDBY FUNCTION**

INPUTS							OUTPUTS	
RESET	CLK	CLK	DCS0	DCS1	Σ OF INPUTS = H D1 - D22	PAR_IN <sup>(1)</sup>	QERR <sup>(2)</sup>	
H	↑	↓	L	X	Even	L	H	
H	↑	↓	L	X	Odd	L	L	
H	↑	↓	L	X	Even	H	L	
H	↑	↓	L	X	Odd	H	H	
H	↑	↓	X	L	Even	L	H	
H	↑	↓	X	L	Odd	L	L	
H	↑	↓	X	L	Even	H	L	
H	↑	↓	X	L	Odd	H	H	
H	↑	↓	H	H	X	X	QERR <sub>0</sub> <sup>(3)</sup>	
H	L or H	L or H	X	X	X	X	QERR <sub>0</sub>	
L	X or floating	X or floating	X or floating	X or floating	X	X or floating	H	

- (1) PAR\_IN arrives one clock cycle after the data to which it applies.
- (2) This transition assumes that QERR is high at the crossing of CLK going high and CLK going low. If QERR goes low, it stays latched low for a minimum of two clock cycles or until RESET is driven low. If two or more consecutive errors occur, the QERR output is driven low and latched low for a clock duration equal to the parity error duration or until RESET is driven low. For QERR computation, CSGEN is a "don't care".
- (3) If DCS0, DCS1 and CSGEN are driven high, the device is placed in a low-power mode (LPM). If a parity error occurs on the clock cycle before the device enters the LPM and the QERR output is driven low, it stays latched low for the LPM duration plus two clock cycles or until RESET is driven low.

## TIMING REQUIREMENTS

over recommended ranges of supply voltage, load, and operating free-air temperature (see [Figure 1](#) and Note <sup>(1)</sup>)

		$V_{CC} = 1.8\text{ V} \pm 0.1\text{ V}$		
		MIN	MAX	UNIT
$f_{(\text{clock})}$	Clock frequency		410	MHz
$t_w$	Pulse duration, CLK, CLK high or low	1		ns
$t_{\text{act}}$	Differential inputs active time (see Note <sup>(2)</sup> )		10	ns
$t_{\text{inact}}$	Differential inputs inactive time (see Note <sup>(3)</sup> )		15	ns
$t_{\text{su}}$	Setup time	$\overline{\text{DCSn}}$ before $\text{CLK}\uparrow$ , $\overline{\text{CLK}}\downarrow$ , CSGEN high	600	ps
		$\overline{\text{DCSn}}$ before $\text{CLK}\uparrow$ , $\overline{\text{CLK}}\downarrow$ , CSGEN low	500	
		$\overline{\text{DODTn}}$ , $\overline{\text{DCKEn}}$ , and Data before $\text{CLK}\uparrow$ , $\overline{\text{CLK}}\downarrow$	500	
		$\overline{\text{PAR\_IN}}$ before $\text{CLK}\uparrow$ , $\overline{\text{CLK}}\downarrow$	500	
$t_h$	Hold time	$\overline{\text{DCSn}}$ , $\overline{\text{DODTn}}$ , $\overline{\text{DCKEn}}$ , and Data after $\text{CLK}\uparrow$ , $\overline{\text{CLK}}\downarrow$	400	ps
		$\overline{\text{PAR\_IN}}$ after $\text{CLK}\uparrow$ , $\overline{\text{CLK}}\downarrow$	400	

(1) All inputs slew rate is 1 V/ns  $\pm 20\%$

(2)  $V_{\text{REF}}$  must be held at a valid input level and data inputs must be held low for a minimum time of  $t_{\text{act}}$  max, after  $\overline{\text{RESET}}$  is taken high.

(3)  $V_{\text{REF}}$ , data, and clock inputs must be held at valid voltage levels (not floating) for a minimum time of  $t_{\text{inact}}$  max, after  $\overline{\text{RESET}}$  is taken low.

## SWITCHING CHARACTERISTICS

over recommended ranges of supply voltage, load, and operating free-air temperature (unless otherwise noted)

			$V_{CC} = 1.8\text{ V} \pm 0.1\text{ V}$		
PARAMETER	FROM (INPUT)	TO (OUTPUT)	MIN	MAX	UNIT
$f_{\text{max}}$ (see <a href="#">Figure 2</a> )			410		MHz
$t_{\text{pdm}}$ <sup>(1)</sup> (production test, see <a href="#">Figure 1</a> )	CLK and $\overline{\text{CLK}}$	Q	0.5	1.0	ns
$t_{\text{PLH}}$ (see <a href="#">Figure 4</a> )	CLK and $\overline{\text{CLK}}$	$\overline{\text{QERR}}$	1.2	3	ns
$t_{\text{PHL}}$ (see <a href="#">Figure 4</a> )			1	2.4	
$t_{\text{RPHL}}$ <sup>(2)</sup> (see <a href="#">Figure 2</a> )	$\overline{\text{RESET}}$	Q		3	ns
$t_{\text{RPLH}}$ (see <a href="#">Figure 4</a> )	$\overline{\text{RESET}}$	$\overline{\text{QERR}}$		3	ns

(1) The typical difference between min and max does not exceed 400 ps.

(2) Includes 350-ps test-load transmission line delay.

## OUTPUT SLEW RATES

over operating free-air temperature range (unless otherwise noted) (see [Figure 3](#))

			$V_{CC} = 1.8\text{ V} \pm 0.1\text{ V}$		
PARAMETER	FROM	TO (OUTPUT)	MIN	MAX	UNIT
$dV/dt_r$	20%	80%	1	5	V/ns
$dV/dt_f$	80%	20%	1	5	V/ns
$dV/dt_{\Delta}$ <sup>(1)</sup>	20% to 80%	20% to 80%		1	V/ns

(1) The difference between  $dV/dt_r$  (rising edge rate) and  $dV/dt_f$  (falling edge).

PARAMETER MEASUREMENT INFORMATION

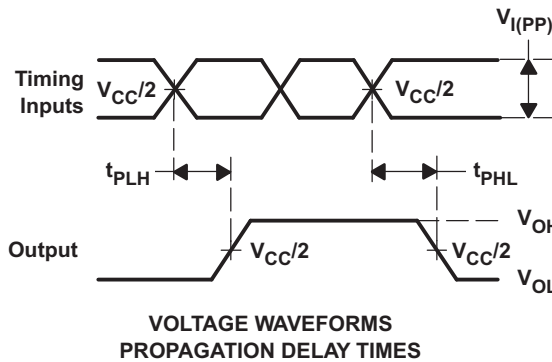
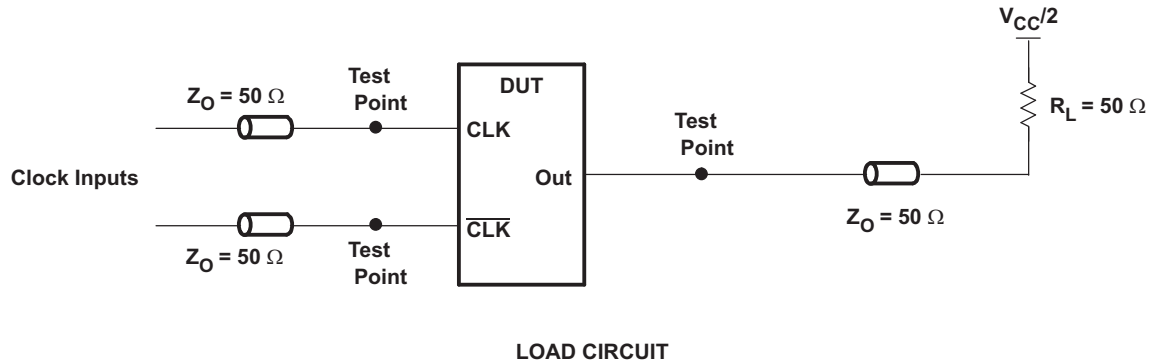
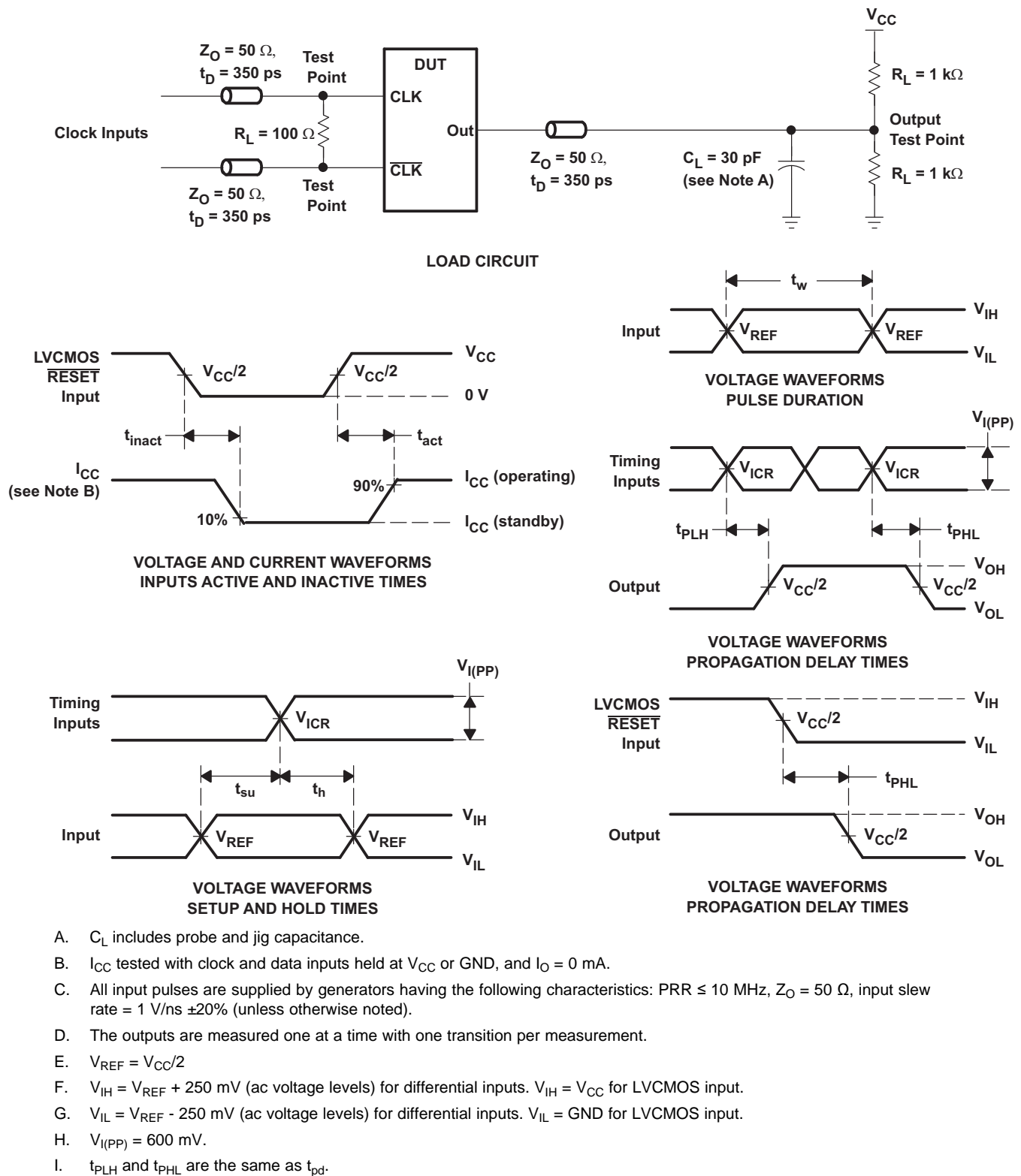

Figure 1. Output Load Circuit for Production Test

Propagation Delay (Design Goal as per JEDEC Specification)

PARAMETER	FROM (INPUT)	TO (OUTPUT)	$V_{CC} = 1.8\text{ V} \pm 0.1\text{ V}$		UNIT
			MIN	MAX	
$t_{pdm}^{(1)}$	CLK and $\overline{\text{CLK}}$	Q	1.1	1.5	ns
$t_{pdmss}^{(1)}$	CLK and $\overline{\text{CLK}}$	Q		1.6	ns

(1) Includes 350-ps test-load transmission line delay.



**Figure 2. Data Output Load Circuit and Voltage Waveforms**

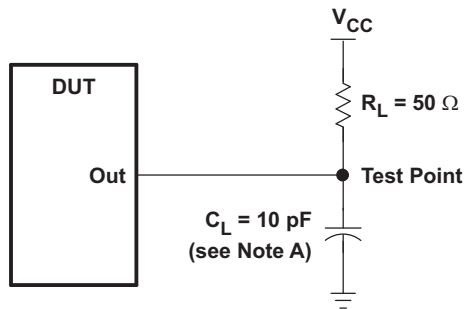

LOAD CIRCUIT  
HIGH-TO-LOW SLEW-RATE MEASUREMENT

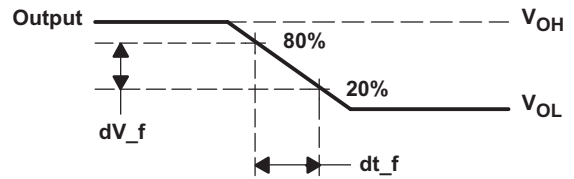

VOLTAGE WAVEFORMS  
HIGH-TO-LOW SLEW-RATE MEASUREMENT

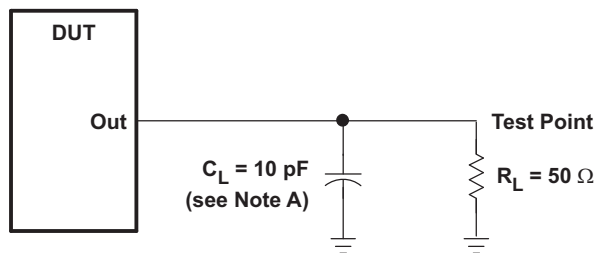

LOAD CIRCUIT  
LOW-TO-HIGH SLEW-RATE MEASUREMENT

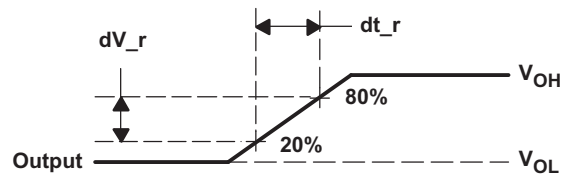

VOLTAGE WAVEFORMS  
LOW-TO-HIGH SLEW-RATE MEASUREMENT

- A.  $C_L$  includes probe and jig capacitance.
- B. All input pulses are supplied by generators having the following characteristics:  
 $PRR \leq 10$  MHz,  $Z_O = 50 \Omega$ , input slew rate =  $1$  V/ns  $\pm 20\%$  (unless otherwise specified).

Figure 3. Data Output Slew-Rate Measurement Information

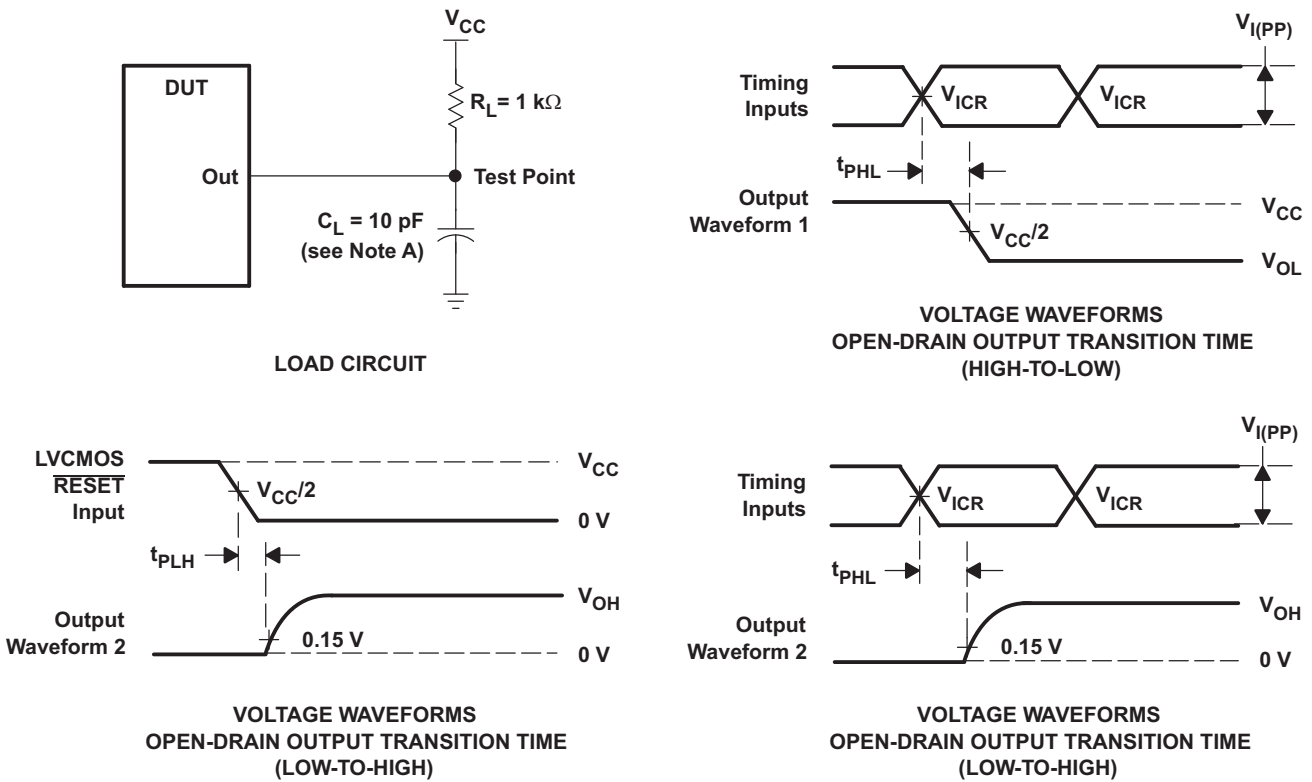

- A.  $C_L$  includes probe and jig capacitance.
- B. All input pulses are supplied by generators having the following characteristics:  
 $PRR \leq 10 \text{ MHz}$ ,  $Z_O = 50 \Omega$ , input slew rate =  $1 \text{ V/ns} \pm 20\%$  (unless otherwise specified).
- C.  $t_{PLH}$  and  $t_{PHL}$  are the same as  $t_{pd}$ .

**Figure 4. Error Output Load Circuit and Voltage Waveforms**

**PACKAGING INFORMATION**

Orderable Device	Status (1)	Package Type	Package Drawing	Pins	Package Qty	Eco Plan (2)	Lead/Ball Finish (6)	MSL Peak Temp (3)	Op Temp (°C)	Device Marking (4/5)	Samples
74SSTUB32868ZRHR	ACTIVE	NFBGA	ZRH	176	1000	Green (RoHS & no Sb/Br)	SNAGCU	Level-3-260C-168 HR	-40 to 85	SB868	<b>Samples</b>

(1) The marketing status values are defined as follows:

**ACTIVE:** Product device recommended for new designs.

**LIFEBUY:** TI has announced that the device will be discontinued, and a lifetime-buy period is in effect.

**NRND:** Not recommended for new designs. Device is in production to support existing customers, but TI does not recommend using this part in a new design.

**PREVIEW:** Device has been announced but is not in production. Samples may or may not be available.

**OBSELETE:** TI has discontinued the production of the device.

(2) Eco Plan - The planned eco-friendly classification: Pb-Free (RoHS), Pb-Free (RoHS Exempt), or Green (RoHS & no Sb/Br) - please check <http://www.ti.com/productcontent> for the latest availability information and additional product content details.

**TBD:** The Pb-Free/Green conversion plan has not been defined.

**Pb-Free (RoHS):** TI's terms "Lead-Free" or "Pb-Free" mean semiconductor products that are compatible with the current RoHS requirements for all 6 substances, including the requirement that lead not exceed 0.1% by weight in homogeneous materials. Where designed to be soldered at high temperatures, TI Pb-Free products are suitable for use in specified lead-free processes.

**Pb-Free (RoHS Exempt):** This component has a RoHS exemption for either 1) lead-based flip-chip solder bumps used between the die and package, or 2) lead-based die adhesive used between the die and leadframe. The component is otherwise considered Pb-Free (RoHS compatible) as defined above.

**Green (RoHS & no Sb/Br):** TI defines "Green" to mean Pb-Free (RoHS compatible), and free of Bromine (Br) and Antimony (Sb) based flame retardants (Br or Sb do not exceed 0.1% by weight in homogeneous material)

(3) MSL, Peak Temp. - The Moisture Sensitivity Level rating according to the JEDEC industry standard classifications, and peak solder temperature.

(4) There may be additional marking, which relates to the logo, the lot trace code information, or the environmental category on the device.

(5) Multiple Device Markings will be inside parentheses. Only one Device Marking contained in parentheses and separated by a "-" will appear on a device. If a line is indented then it is a continuation of the previous line and the two combined represent the entire Device Marking for that device.

(6) Lead/Ball Finish - Orderable Devices may have multiple material finish options. Finish options are separated by a vertical ruled line. Lead/Ball Finish values may wrap to two lines if the finish value exceeds the maximum column width.

**Important Information and Disclaimer:**The information provided on this page represents TI's knowledge and belief as of the date that it is provided. TI bases its knowledge and belief on information provided by third parties, and makes no representation or warranty as to the accuracy of such information. Efforts are underway to better integrate information from third parties. TI has taken and continues to take reasonable steps to provide representative and accurate information but may not have conducted destructive testing or chemical analysis on incoming materials and chemicals. TI and TI suppliers consider certain information to be proprietary, and thus CAS numbers and other limited information may not be available for release.

In no event shall TI's liability arising out of such information exceed the total purchase price of the TI part(s) at issue in this document sold by TI to Customer on an annual basis.



## TAPE AND REEL INFORMATION



### QUADRANT ASSIGNMENTS FOR PIN 1 ORIENTATION IN TAPE



\*All dimensions are nominal

Device	Package Type	Package Drawing	Pins	SPQ	Reel Diameter (mm)	Reel Width W1 (mm)	A0 (mm)	B0 (mm)	K0 (mm)	P1 (mm)	W (mm)	Pin1 Quadrant
74SSTUB32868ZRHR	NFBGA	ZRH	176	1000	330.0	24.4	6.3	15.3	1.65	12.0	24.0	Q1

**TAPE AND REEL BOX DIMENSIONS**



\*All dimensions are nominal

Device	Package Type	Package Drawing	Pins	SPQ	Length (mm)	Width (mm)	Height (mm)
74SSTUB32868ZRHR	NFBGA	ZRH	176	1000	336.6	336.6	31.8

ZRH (R-PBGA-N176)

PLASTIC BALL GRID ARRAY

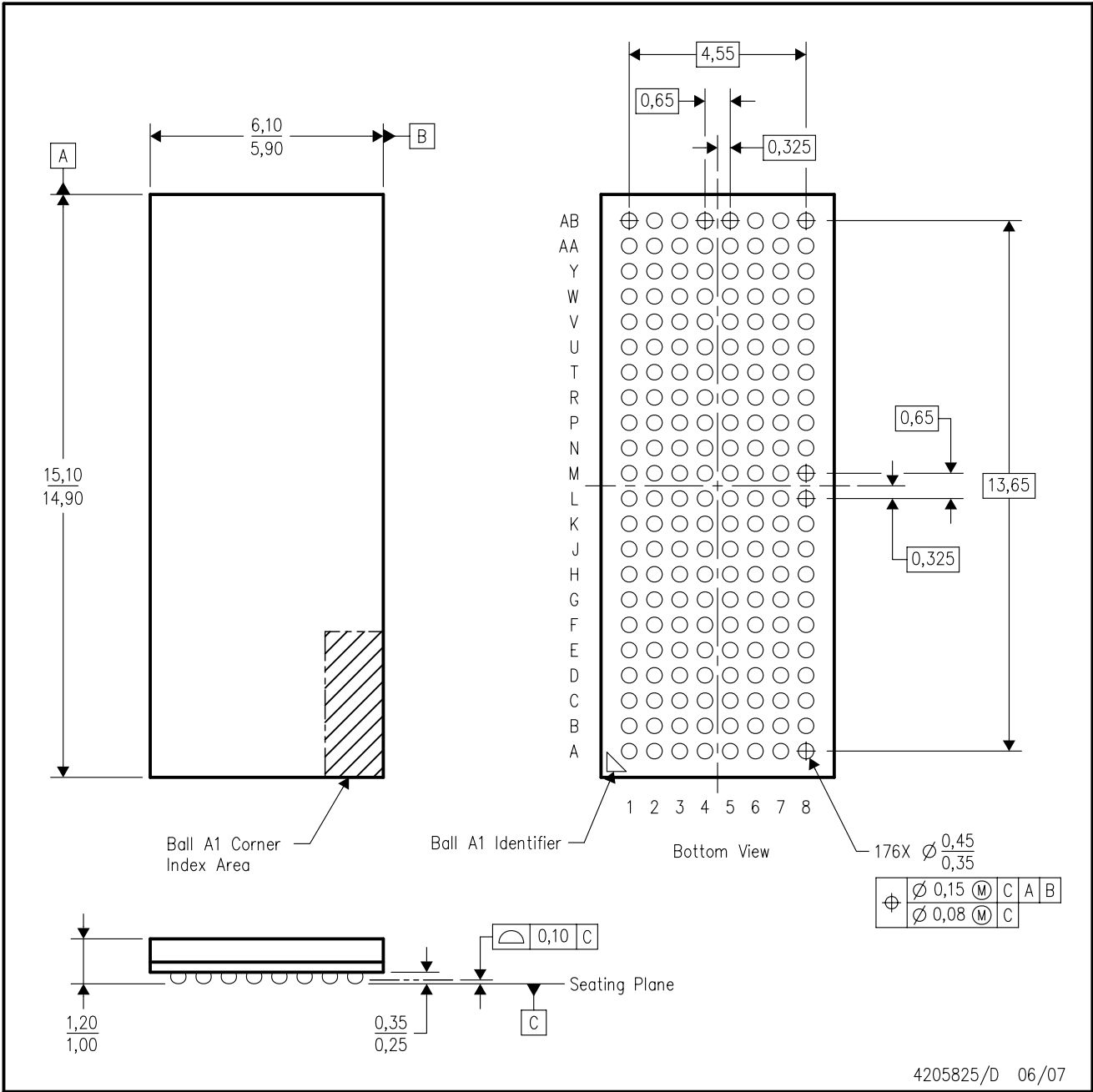

4205825/D 06/07

- NOTES:
- A. All linear dimensions are in millimeters. Dimensioning and tolerancing per ASME Y14.5M-1994.
  - B. This drawing is subject to change without notice.
  - C. Complies to JEDEC MO-246 variation B.
  - D. This package is lead-free. Refer to the 176 GRH package (drawing 4205824) for tin-lead (SnPb).

## IMPORTANT NOTICE

Texas Instruments Incorporated and its subsidiaries (TI) reserve the right to make corrections, enhancements, improvements and other changes to its semiconductor products and services per JESD46, latest issue, and to discontinue any product or service per JESD48, latest issue. Buyers should obtain the latest relevant information before placing orders and should verify that such information is current and complete. All semiconductor products (also referred to herein as "components") are sold subject to TI's terms and conditions of sale supplied at the time of order acknowledgment.

TI warrants performance of its components to the specifications applicable at the time of sale, in accordance with the warranty in TI's terms and conditions of sale of semiconductor products. Testing and other quality control techniques are used to the extent TI deems necessary to support this warranty. Except where mandated by applicable law, testing of all parameters of each component is not necessarily performed.

TI assumes no liability for applications assistance or the design of Buyers' products. Buyers are responsible for their products and applications using TI components. To minimize the risks associated with Buyers' products and applications, Buyers should provide adequate design and operating safeguards.

TI does not warrant or represent that any license, either express or implied, is granted under any patent right, copyright, mask work right, or other intellectual property right relating to any combination, machine, or process in which TI components or services are used. Information published by TI regarding third-party products or services does not constitute a license to use such products or services or a warranty or endorsement thereof. Use of such information may require a license from a third party under the patents or other intellectual property of the third party, or a license from TI under the patents or other intellectual property of TI.

Reproduction of significant portions of TI information in TI data books or data sheets is permissible only if reproduction is without alteration and is accompanied by all associated warranties, conditions, limitations, and notices. TI is not responsible or liable for such altered documentation. Information of third parties may be subject to additional restrictions.

Resale of TI components or services with statements different from or beyond the parameters stated by TI for that component or service voids all express and any implied warranties for the associated TI component or service and is an unfair and deceptive business practice. TI is not responsible or liable for any such statements.

Buyer acknowledges and agrees that it is solely responsible for compliance with all legal, regulatory and safety-related requirements concerning its products, and any use of TI components in its applications, notwithstanding any applications-related information or support that may be provided by TI. Buyer represents and agrees that it has all the necessary expertise to create and implement safeguards which anticipate dangerous consequences of failures, monitor failures and their consequences, lessen the likelihood of failures that might cause harm and take appropriate remedial actions. Buyer will fully indemnify TI and its representatives against any damages arising out of the use of any TI components in safety-critical applications.

In some cases, TI components may be promoted specifically to facilitate safety-related applications. With such components, TI's goal is to help enable customers to design and create their own end-product solutions that meet applicable functional safety standards and requirements. Nonetheless, such components are subject to these terms.

No TI components are authorized for use in FDA Class III (or similar life-critical medical equipment) unless authorized officers of the parties have executed a special agreement specifically governing such use.

Only those TI components which TI has specifically designated as military grade or "enhanced plastic" are designed and intended for use in military/aerospace applications or environments. Buyer acknowledges and agrees that any military or aerospace use of TI components which have **not** been so designated is solely at the Buyer's risk, and that Buyer is solely responsible for compliance with all legal and regulatory requirements in connection with such use.

TI has specifically designated certain components as meeting ISO/TS16949 requirements, mainly for automotive use. In any case of use of non-designated products, TI will not be responsible for any failure to meet ISO/TS16949.

### Products

Audio	<a href="http://www.ti.com/audio">www.ti.com/audio</a>
Amplifiers	<a href="http://amplifier.ti.com">amplifier.ti.com</a>
Data Converters	<a href="http://dataconverter.ti.com">dataconverter.ti.com</a>
DLP® Products	<a href="http://www.dlp.com">www.dlp.com</a>
DSP	<a href="http://dsp.ti.com">dsp.ti.com</a>
Clocks and Timers	<a href="http://www.ti.com/clocks">www.ti.com/clocks</a>
Interface	<a href="http://interface.ti.com">interface.ti.com</a>
Logic	<a href="http://logic.ti.com">logic.ti.com</a>
Power Mgmt	<a href="http://power.ti.com">power.ti.com</a>
Microcontrollers	<a href="http://microcontroller.ti.com">microcontroller.ti.com</a>
RFID	<a href="http://www.ti-rfid.com">www.ti-rfid.com</a>
OMAP Applications Processors	<a href="http://www.ti.com/omap">www.ti.com/omap</a>
Wireless Connectivity	<a href="http://www.ti.com/wirelessconnectivity">www.ti.com/wirelessconnectivity</a>

### Applications

Automotive and Transportation	<a href="http://www.ti.com/automotive">www.ti.com/automotive</a>
Communications and Telecom	<a href="http://www.ti.com/communications">www.ti.com/communications</a>
Computers and Peripherals	<a href="http://www.ti.com/computers">www.ti.com/computers</a>
Consumer Electronics	<a href="http://www.ti.com/consumer-apps">www.ti.com/consumer-apps</a>
Energy and Lighting	<a href="http://www.ti.com/energy">www.ti.com/energy</a>
Industrial	<a href="http://www.ti.com/industrial">www.ti.com/industrial</a>
Medical	<a href="http://www.ti.com/medical">www.ti.com/medical</a>
Security	<a href="http://www.ti.com/security">www.ti.com/security</a>
Space, Avionics and Defense	<a href="http://www.ti.com/space-avionics-defense">www.ti.com/space-avionics-defense</a>
Video and Imaging	<a href="http://www.ti.com/video">www.ti.com/video</a>

### TI E2E Community

[e2e.ti.com](http://e2e.ti.com)

## Looking for pricing, stock, or lifecycle information?

Click below to explore more details on WIN SOURCE:

 [View 74SSTUB32868ZRHR on WIN SOURCE](#)

 [Texas Instruments](#) Information

## Optimize Your Supply Chain with WIN SOURCE Solutions

-  Global Sourcing Solution
-  Obsolete Management
-  Cost Control Management
-  Shortage Management
-  Alternative Solution
-  Excess Inventory Management