



**THE DATASHEET OF
74LVT162374DGG,118**



74LVT162374

3.3 V 16-bit edge-triggered D-type flip-flop with 30 Ω termination resistors; 3-state

Rev. 4 — 1 October 2018

Product data sheet

1. General description

The 74LVT162374 is a high performance BiCMOS product designed for V_{CC} operation at 3.3 V.

The 74LVT162374 is designed with 30 Ω series resistance in both the HIGH and LOW states of the output. This design reduces line noise in applications such as memory address drivers, clock drivers, and bus receivers/transmitters.

This device is a 16-bit edge-triggered D-type flip-flop featuring non-inverting 3-state outputs. The device can be used as two 8-bit flip-flops or one 16-bit flip-flop. On the positive transition of the clock (CP), the Q outputs of the flip-flop take on the logic levels set up at the D inputs.

2. Features and benefits

- 16-bit edge-triggered flip-flop
- 3-state buffers
- Output capability: +12 mA and -12 mA
- TTL input and output switching levels
- Input and output interface capability to systems at 5 V supply
- Bus-hold data inputs eliminate the need for external pull-up resistors to hold unused inputs
- Live insertion and extraction permitted
- Outputs include series resistance of 30 Ω making external resistors unnecessary
- Power-up reset
- Power-up 3-state
- No bus current loading when output is tied to 5 V bus
- Latch-up protection:
 - JESD78B Class II exceeds 500 mA
- ESD protection:
 - HBM: JESD22-A114F exceeds 2000 V
 - MM: JESD22-A115-A exceeds 200 V

3. Ordering information

Table 1. Ordering information

Type number	Package			
	Temperature range	Name	Description	Version
74LVT162374DGG	-40 °C to +85 °C	TSSOP48	plastic thin shrink small outline package; 48 leads; body width 6.1 mm	SOT362-1

4. Functional diagram

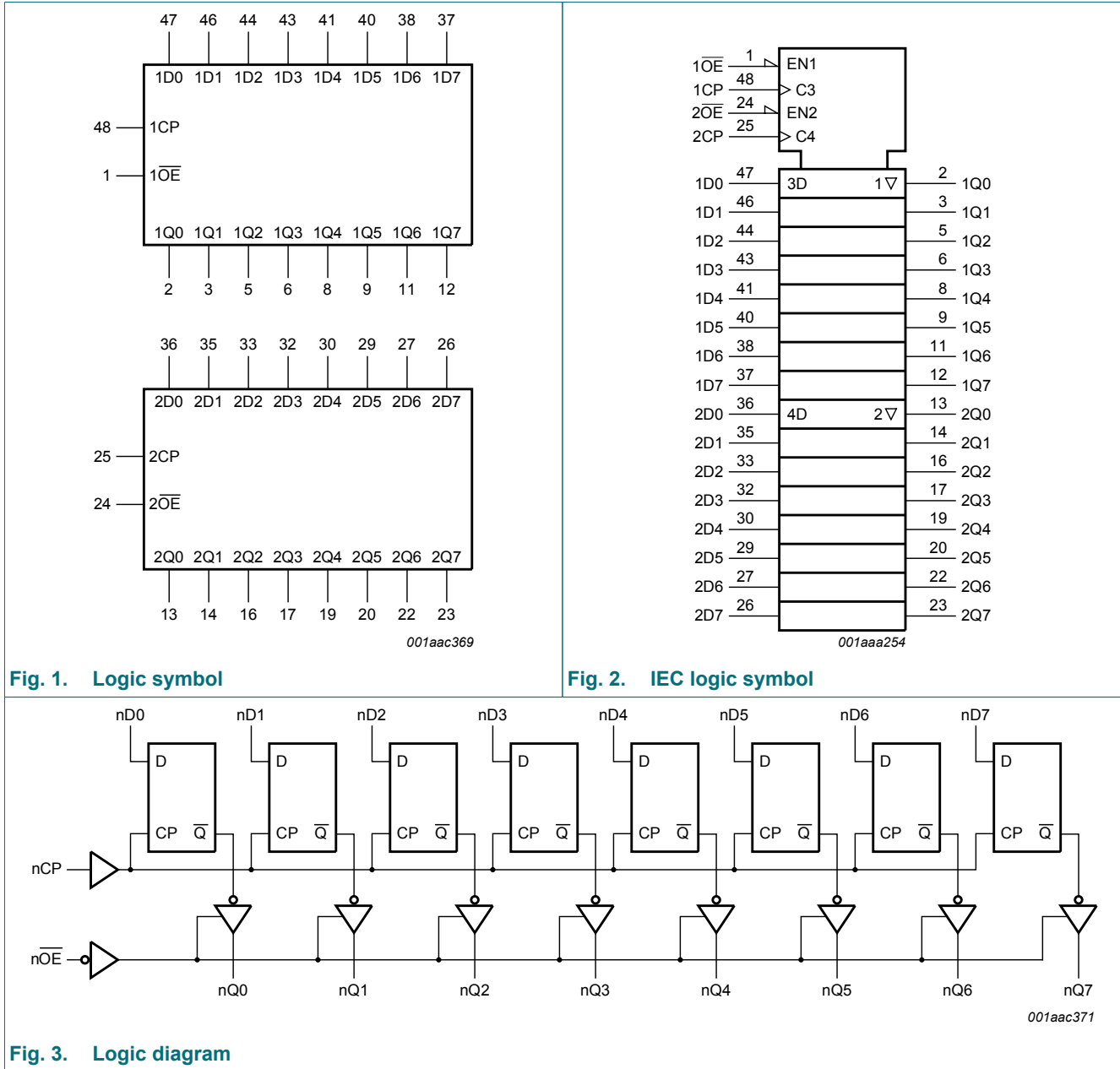

3.3 V 16-bit edge-triggered D-type flip-flop with 30 Ω termination resistors; 3-state

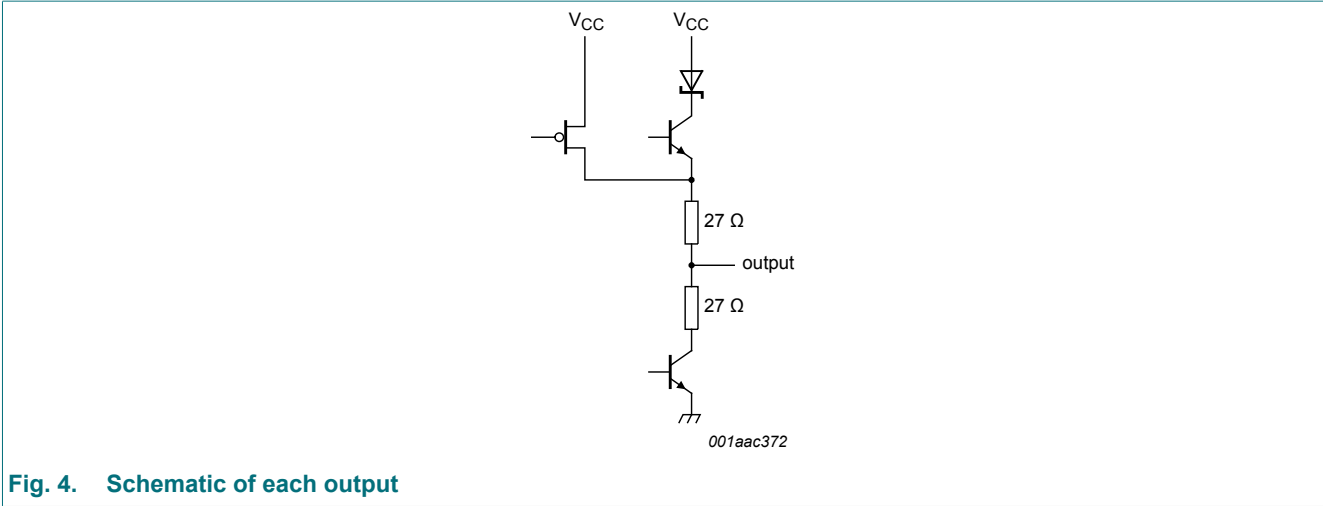

Fig. 4. Schematic of each output

5. Pinning information

5.1. Pinning

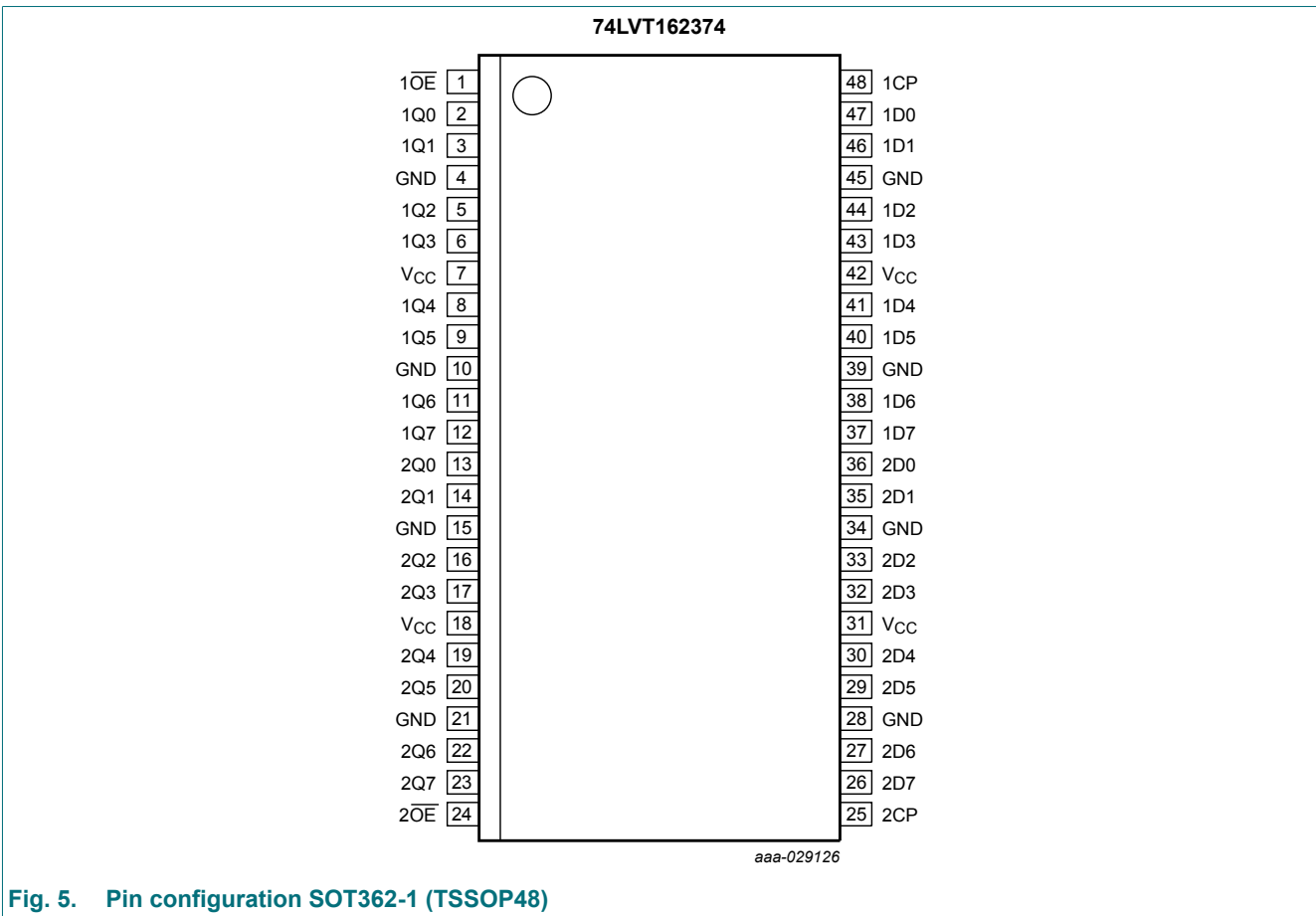

Fig. 5. Pin configuration SOT362-1 (TSSOP48)

5.2. Pin description

Table 2. Pin description

Symbol	Pin	Description
1D0, 1D1, 1D2, 1D3, 1D4, 1D5, 1D6, 1D7	47, 46, 44, 43, 41, 40, 38, 37	data inputs
2D0, 2D1, 2D2, 2D3, 2D4, 2D5, 2D6, 2D7	36, 35, 33, 32, 30, 29, 27, 26	data inputs
1Q0, 1Q1, 1Q2, 1Q3, 1Q4, 1Q5, 1Q6, 1Q7	2, 3, 5, 6, 8, 9, 11, 12	data outputs
2Q0, 2Q1, 2Q2, 2Q3, 2Q4, 2Q5, 2Q6, 2Q7	13, 14, 16, 17, 19, 20, 22, 23	data outputs
1OE, 2OE	1, 24	output enable inputs (active LOW)
1CP, 2CP	48, 25	clock pulse inputs (active rising edge)
GND	4, 10, 15, 21, 28, 34, 39, 45	ground (0 V)
V _{CC}	7, 18, 31, 42	supply voltage

6. Functional description

Table 3. Function table [1]

Operating mode	Input			Internal flip-flops	Output nQn
	nOE	nCP	nDn		
Load and read register	L	↑	l	L	L
	L	↑	h	H	H
Hold	L	NC	X	NC	NC
Disable outputs	H	NC	X	NC	Z
	H	↑	nDn	nDn	Z

- [1] H = HIGH voltage level;
 L = LOW voltage level;
 h = HIGH voltage level one set-up time prior to the LOW-to-HIGH clock transition;
 l = LOW voltage level one set-up time prior to the LOW-to-HIGH clock transition;
 NC = no change;
 X = don't care;
 Z = high-impedance OFF-state;
 ↑ = LOW-to-HIGH clock transition.

7. Limiting values

Table 4. Limiting values

In accordance with the Absolute Maximum Rating System (IEC 60134). Voltages are referenced to GND (ground = 0 V)

Symbol	Parameter	Conditions	Min	Max	Unit
V _{CC}	supply voltage		-0.5	+4.6	V
V _I	input voltage		[1] -0.5	+7.0	V
V _O	output voltage	output in OFF-state or HIGH-state	[1] -0.5	+7.0	V
I _{IK}	input clamping current	V _I < 0 V	-50	-	mA
I _{OK}	output clamping current	V _O < 0 V	-50	-	mA
I _O	output current	output in LOW-state	-	128	mA
		output in HIGH-state	-64	-	mA
T _{stg}	storage temperature		-65	+150	°C

3.3 V 16-bit edge-triggered D-type flip-flop with 30 Ω termination resistors; 3-state

Symbol	Parameter	Conditions	Min	Max	Unit
T_j	junction temperature	[2]		+150	$^{\circ}\text{C}$

- [1] The input and output negative voltage ratings may be exceeded if the input and output clamp current ratings are observed.
 [2] The performance capability of a high-performance integrated circuit in conjunction with its thermal environment can create junction temperatures which are detrimental to reliability.

8. Recommended operating conditions

Table 5. Recommended operating conditions

Symbol	Parameter	Conditions	Min	Typ	Max	Unit
V_{CC}	supply voltage		2.7	-	3.6	V
V_I	input voltage		0	-	5.5	V
$\Delta t/\Delta V$	input transition rise and fall rate	outputs enabled	-	-	10	ns/V
T_{amb}	ambient temperature		-40	-	+85	$^{\circ}\text{C}$

9. Static characteristics

Table 6. Static characteristics

At recommended operating conditions; voltages are referenced to GND (ground = 0 V).

Symbol	Parameter	Conditions	Min	Typ[1]	Max	Unit
V_{IK}	input clamping voltage	$V_{CC} = 2.7\text{ V}; I_{IK} = -18\text{ mA}$	-	-0.85	-1.2	V
V_{IH}	HIGH-level input voltage		2.0	-	-	V
V_{IL}	LOW-level input voltage		-	-	0.8	V
V_{OH}	HIGH-level output voltage	$V_{CC} = 3.0\text{ V}; I_{OH} = -12\text{ mA}$	2.0	-	-	V
V_{OL}	LOW-level output voltage	$V_{CC} = 3.0\text{ V}; I_{OL} = 12\text{ mA}$	-	-	0.8	V
I_{OH}	HIGH-level output current		-	-	-12	mA
I_{OL}	LOW-level output current		-	-	12	mA
$V_{OL(pu)}$	power-up LOW-level output voltage	$V_{CC} = 3.6\text{ V}; I_O = 1\text{ mA}; V_I = \text{GND or } V_{CC}$ [2]	-	0.1	0.55	V
I_I	input leakage current	all input pins [3]				
		$V_{CC} = 0\text{ V or } 3.6\text{ V}; V_I = 5.5\text{ V}$	-	0.4	10	μA
		control pins [3]				
		$V_{CC} = 3.6\text{ V}; V_I = V_{CC}\text{ or GND}$	-	0.1	± 1	μA
		I/O data pins; $V_{CC} = 3.6\text{ V}$ [3]				
	$V_I = V_{CC}$	-	0.1	1	μA	
	$V_I = 0\text{ V}$	-	-0.4	-5	μA	
I_{OFF}	power-off leakage current	$V_{CC} = 0\text{ V}; V_I\text{ or } V_O = 0\text{ V to } 4.5\text{ V}$	-	0.1	± 100	μA
I_{BHL}	bus hold LOW current	nDn inputs; $V_{CC} = 3\text{ V}; V_I = 0.8\text{ V}$	75	135	-	μA
I_{BHH}	bus hold HIGH current	nDn inputs; $V_{CC} = 3\text{ V}; V_I = 2.0\text{ V}$	-75	-135	-	μA
I_{BHLO}	bus hold LOW overdrive current	nDn inputs; $V_{CC} = 3.6\text{ V}; V_I = 0\text{ V to } 3.6\text{ V}$ [4]	500	-	-	μA
I_{BHHO}	bus hold HIGH overdrive current	nDn inputs; $V_{CC} = 3.6\text{ V}; V_I = 0\text{ V to } 3.6\text{ V}$ [4]	-	-	-500	μA
I_{CEX}	output high leakage current	output in HIGH-state when $V_O > V_{CC}$; $V_O = 5.5\text{ V}; V_{CC} = 3.0\text{ V}$	-	50	125	μA
$I_{O(pu/pd)}$	power-up/power-down output current	$V_{CC} \leq 1.2\text{ V}; V_O = 5.0\text{ V to } V_{CC}$; $V_I = \text{GND or } V_{CC}$; n $\overline{\text{OE}}$ = don't care [5]	-	1	± 100	μA

3.3 V 16-bit edge-triggered D-type flip-flop with 30 Ω termination resistors; 3-state

Symbol	Parameter	Conditions	Min	Typ[1]	Max	Unit
I_{OZ}	OFF-state output current	$V_{CC} = 3.6\text{ V}$; $V_I = V_{IH}$ or V_{IL}				
		$V_O = 3.0\text{ V}$	-	0.5	5	μA
		$V_O = 0.5\text{ V}$	-	0.5	-5	μA
I_{CC}	supply current	$V_{CC} = 3.6\text{ V}$; $V_I = \text{GND}$ or V_{CC} ; $I_O = 0\text{ A}$				
		outputs HIGH	-	0.07	0.12	mA
		outputs LOW	-	4	6	mA
		outputs disabled [6]	-	0.07	0.12	mA
ΔI_{CC}	additional supply current	per input pin; $V_{CC} = 3\text{ V}$ to 3.6 V ; one input at $V_{CC} - 0.6\text{ V}$; other inputs at V_{CC} or GND [7]	-	0.1	0.2	mA
C_I	input capacitance	$V_I = 0\text{ V}$ or 3.0 V	-	3	-	pF
C_O	output capacitance	outputs disabled; $V_O = 0\text{ V}$ or 3.0 V	-	9	-	pF

[1] All typical values are measured at $V_{CC} = 3.3\text{ V}$ and $T_{amb} = 25\text{ }^\circ\text{C}$.

[2] For valid test results, data must not be loaded into the flip-flops after applying power.

[3] Unused pins at V_{CC} or GND.

[4] This is the bus-hold overdrive current required to force the input to the opposite logic state.

[5] This parameter is valid for any V_{CC} between 0 V and 1.2 V with a transition time of up to 10 ms . From $V_{CC} = 1.2\text{ V}$ to $V_{CC} = 3.3\text{ V} \pm 0.3\text{ V}$ a transition time of $100\text{ }\mu\text{s}$ is permitted. This parameter is valid for $T_{amb} = 25\text{ }^\circ\text{C}$ only.

[6] I_{CC} is measured with outputs pulled to V_{CC} or GND.

[7] This is the increase in supply current for each input at the specified voltage level other than V_{CC} or GND.

10. Dynamic characteristics

Table 7. Dynamic characteristics

At recommended operating conditions; Voltages are referenced to GND (ground = 0 V); for test circuit see Fig. 9.

Symbol	Parameter	Conditions	Min	Typ[1]	Max	Unit
f_{max}	maximum frequency	nCP; $V_{CC} = 3.0\text{ V}$ to 3.6 V ; see Fig. 6	150	-	-	MHz
t_{PLH}	LOW to HIGH propagation delay	nCP to nQn; see Fig. 6				
		$V_{CC} = 2.7\text{ V}$	-	-	6.2	ns
		$V_{CC} = 3.0\text{ V}$ to 3.6 V	1.5	3.0	5.3	ns
t_{PHL}	HIGH to LOW propagation delay	nCP to nQn; see Fig. 6				
		$V_{CC} = 2.7\text{ V}$	-	-	5.1	ns
		$V_{CC} = 3.0\text{ V}$ to 3.6 V	1.5	3.0	4.9	ns
t_{PZH}	OFF-state to HIGH propagation delay	n \overline{OE} to nQn; see Fig. 8				
		$V_{CC} = 2.7\text{ V}$	-	-	6.9	ns
		$V_{CC} = 3.0\text{ V}$ to 3.6 V	1.5	3.5	5.6	ns
t_{PZL}	OFF-state to LOW propagation delay	n \overline{OE} to nQn; see Fig. 8				
		$V_{CC} = 2.7\text{ V}$	-	-	6.0	ns
		$V_{CC} = 3.0\text{ V}$ to 3.6 V	1.5	3.2	4.9	ns
t_{PHZ}	HIGH to OFF-state propagation delay	n \overline{OE} to nQn; see Fig. 8				
		$V_{CC} = 2.7\text{ V}$	-	-	5.7	ns
		$V_{CC} = 3.0\text{ V}$ to 3.6 V	1.5	3.5	5.4	ns
t_{PLZ}	LOW to OFF-state propagation delay	n \overline{OE} to nQn; see Fig. 8				
		$V_{CC} = 2.7\text{ V}$	-	-	5.1	ns
		$V_{CC} = 3.0\text{ V}$ to 3.6 V	1.5	3.2	5.0	ns

3.3 V 16-bit edge-triggered D-type flip-flop with 30 Ω termination resistors; 3-state

Symbol	Parameter	Conditions	Min	Typ[1]	Max	Unit
t _{su}	set-up time	nDn to nCP; see Fig. 7				
		V _{CC} = 2.7 V	2.0	-	-	ns
		V _{CC} = 3.0 V to 3.6 V	2.0	0.7	-	ns
t _h	hold time	nDn to nCP; see Fig. 7				
		V _{CC} = 2.7 V	0.1	-	-	ns
		V _{CC} = 3.0 V to 3.6 V	0.8	0	-	ns
t _{WH}	pulse width HIGH	nCP; see Fig. 6				
		V _{CC} = 2.7 V	1.5	-	-	ns
		V _{CC} = 3.0 V to 3.6 V	1.5	0.6	-	ns
t _{WL}	pulse width LOW	nCP				
		V _{CC} = 2.7 V	3.0	-	-	ns
		V _{CC} = 3.0 V to 3.6 V	3.0	1.6	-	ns

[1] Typical values are measured at V_{CC} = 3.3 V and T_{amb} = 25 °C.

10.1. Waveforms and test circuit

001aal773

Measurement points are given in Table 8.
V_{OL} and V_{OH} are typical voltage output levels that occur with the output load.

Fig. 6. Clock input (nCP) to output (nQn) propagation delay, clock pulse width and maximum clock frequency

001aal774

Measurement points are given in Table 8.
The shaded areas indicate when the input is permitted to change for predictable output performance.

Fig. 7. Data set-up and hold times for input (nDn) to input (nCP)

aaa-029125

Measurement points are given in Table 8.
V_{OL} and V_{OH} are typical voltage output levels that occur with the output load.

Fig. 8. 3-state output enable and disable times

3.3 V 16-bit edge-triggered D-type flip-flop with 30 Ω termination resistors; 3-state

Table 8. Measurement points

Input		Output		
V_I	V_M	V_M	V_X	V_Y
2.7 V	1.5 V	1.5 V	$V_{OL} + 0.3 V$	$V_{OH} - 0.3 V$

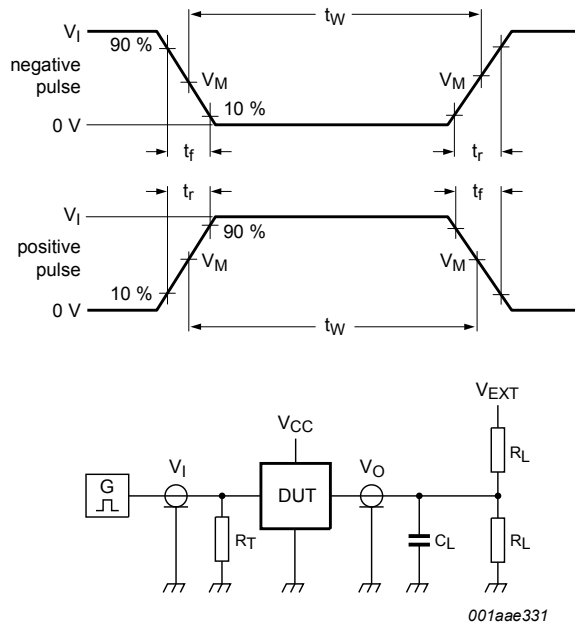

Test data is given in [Table 9](#).

Definitions:

R_L = Load resistance.

C_L = Load capacitance including jig and probe capacitance.

R_T = Termination resistance should be equal to output impedance Z_o of the pulse generator.

V_{EXT} = Test voltage for switching times.

Fig. 9. Test circuit for measuring switching times

Table 9. Test data

Input				Load		V_{EXT}		
V_I	f_i	t_W	t_r, t_f	C_L	R_L	t_{PHZ}, t_{PZH}	t_{PLZ}, t_{PZL}	t_{PLH}, t_{PHL}
2.7 V	$\leq 10 \text{ MHz}$	500 ns	$\leq 2.5 \text{ ns}$	50 pF	500 Ω	GND	6 V	open

11. Package outline

TSSOP48: plastic thin shrink small outline package; 48 leads; body width 6.1 mm

SOT362-1

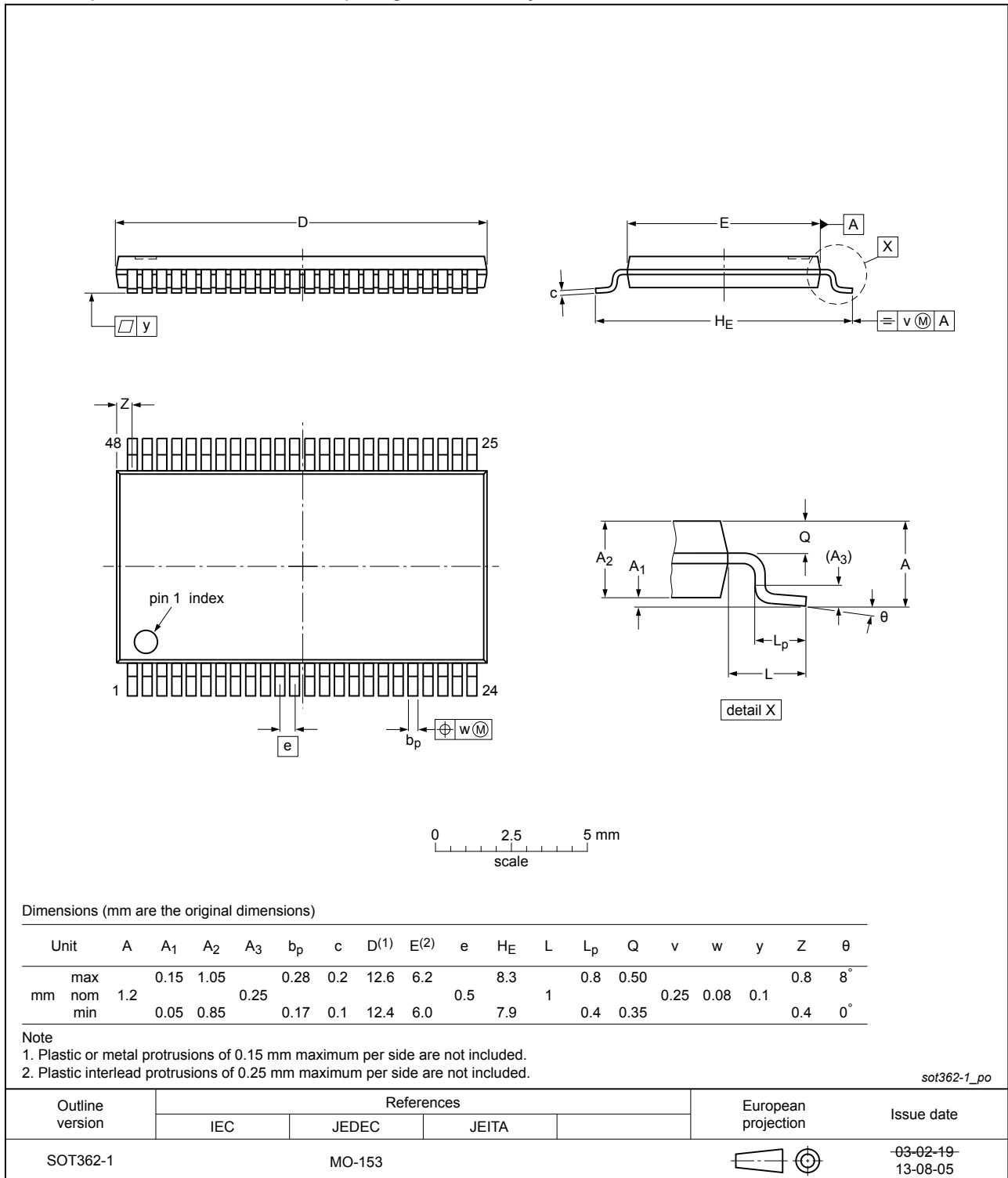

Fig. 10. Package outline SOT362-1 (TSSOP48)

12. Abbreviations

Table 10. Abbreviations

Acronym	Description
BiCMOS	Bipolar Complementary Metal Oxide Semiconductor
DUT	Device Under Test
ESD	ElectroStatic Discharge
MIL	Military
MM	Machine Model
TTL	Transistor-Transistor Logic

13. Revision history

Table 11. Revision history

Document ID	Release date	Data sheet status	Change notice	Supersedes
74LVT162374 v.4	20181001	Product data sheet	-	74LVT162374 v.3
Modifications:	<ul style="list-style-type: none"> The format of this data sheet has been redesigned to comply with the identity guidelines of Nexperia. Legal texts have been adapted to the new company name where appropriate. Type number 74LVT162374DL (SOT370-1) removed Section "Quick reference data" removed 			
74LVT162374 v.3	20050117	Product data sheet	-	74LVT162374 v.2
Modifications:	<ul style="list-style-type: none"> The format of this data sheet is redesigned to comply with the current presentation and information standard of Philips Semiconductors. Section 2: Changed JEDEC Std 17 into JESD78 Table 1 "Quick reference data": Changed t_{PLH} and t_{PHL} propagation delays nCP to nQn to 3.0 ns Table 7: Changed the minimum values of $t_{h(H)}$ and $t_{h(L)}$ hold time nDn to nCP to 0.8 ns 			
74LVT162374 v.2	20040922	Product specification	-	74LVT162374 v.1
74LVT162374 v.1	19990923	Product specification	-	-

3.3 V 16-bit edge-triggered D-type flip-flop with 30 Ω termination resistors; 3-state

14. Legal information

Data sheet status

Document status [1][2]	Product status [3]	Definition
Objective [short] data sheet	Development	This document contains data from the objective specification for product development.
Preliminary [short] data sheet	Qualification	This document contains data from the preliminary specification.
Product [short] data sheet	Production	This document contains the product specification.

- [1] Please consult the most recently issued document before initiating or completing a design.
- [2] The term 'short data sheet' is explained in section "Definitions".
- [3] The product status of device(s) described in this document may have changed since this document was published and may differ in case of multiple devices. The latest product status information is available on the internet at <https://www.nexperia.com>.

Definitions

Draft — The document is a draft version only. The content is still under internal review and subject to formal approval, which may result in modifications or additions. Nexperia does not give any representations or warranties as to the accuracy or completeness of information included herein and shall have no liability for the consequences of use of such information.

Short data sheet — A short data sheet is an extract from a full data sheet with the same product type number(s) and title. A short data sheet is intended for quick reference only and should not be relied upon to contain detailed and full information. For detailed and full information see the relevant full data sheet, which is available on request via the local Nexperia sales office. In case of any inconsistency or conflict with the short data sheet, the full data sheet shall prevail.

Product specification — The information and data provided in a Product data sheet shall define the specification of the product as agreed between Nexperia and its customer, unless Nexperia and customer have explicitly agreed otherwise in writing. In no event however, shall an agreement be valid in which the Nexperia product is deemed to offer functions and qualities beyond those described in the Product data sheet.

Disclaimers

Limited warranty and liability — Information in this document is believed to be accurate and reliable. However, Nexperia does not give any representations or warranties, expressed or implied, as to the accuracy or completeness of such information and shall have no liability for the consequences of use of such information. Nexperia takes no responsibility for the content in this document if provided by an information source outside of Nexperia.

In no event shall Nexperia be liable for any indirect, incidental, punitive, special or consequential damages (including - without limitation - lost profits, lost savings, business interruption, costs related to the removal or replacement of any products or rework charges) whether or not such damages are based on tort (including negligence), warranty, breach of contract or any other legal theory.

Notwithstanding any damages that customer might incur for any reason whatsoever, Nexperia's aggregate and cumulative liability towards customer for the products described herein shall be limited in accordance with the Terms and conditions of commercial sale of Nexperia.

Right to make changes — Nexperia reserves the right to make changes to information published in this document, including without limitation specifications and product descriptions, at any time and without notice. This document supersedes and replaces all information supplied prior to the publication hereof.

Suitability for use — Nexperia products are not designed, authorized or warranted to be suitable for use in life support, life-critical or safety-critical systems or equipment, nor in applications where failure or malfunction of an Nexperia product can reasonably be expected to result in personal

injury, death or severe property or environmental damage. Nexperia and its suppliers accept no liability for inclusion and/or use of Nexperia products in such equipment or applications and therefore such inclusion and/or use is at the customer's own risk.

Quick reference data — The Quick reference data is an extract of the product data given in the Limiting values and Characteristics sections of this document, and as such is not complete, exhaustive or legally binding.

Applications — Applications that are described herein for any of these products are for illustrative purposes only. Nexperia makes no representation or warranty that such applications will be suitable for the specified use without further testing or modification.

Customers are responsible for the design and operation of their applications and products using Nexperia products, and Nexperia accepts no liability for any assistance with applications or customer product design. It is customer's sole responsibility to determine whether the Nexperia product is suitable and fit for the customer's applications and products planned, as well as for the planned application and use of customer's third party customer(s). Customers should provide appropriate design and operating safeguards to minimize the risks associated with their applications and products.

Nexperia does not accept any liability related to any default, damage, costs or problem which is based on any weakness or default in the customer's applications or products, or the application or use by customer's third party customer(s). Customer is responsible for doing all necessary testing for the customer's applications and products using Nexperia products in order to avoid a default of the applications and the products or of the application or use by customer's third party customer(s). Nexperia does not accept any liability in this respect.

Limiting values — Stress above one or more limiting values (as defined in the Absolute Maximum Ratings System of IEC 60134) will cause permanent damage to the device. Limiting values are stress ratings only and (proper) operation of the device at these or any other conditions above those given in the Recommended operating conditions section (if present) or the Characteristics sections of this document is not warranted. Constant or repeated exposure to limiting values will permanently and irreversibly affect the quality and reliability of the device.

Terms and conditions of commercial sale — Nexperia products are sold subject to the general terms and conditions of commercial sale, as published at <http://www.nexperia.com/profile/terms>, unless otherwise agreed in a valid written individual agreement. In case an individual agreement is concluded only the terms and conditions of the respective agreement shall apply. Nexperia hereby expressly objects to applying the customer's general terms and conditions with regard to the purchase of Nexperia products by customer.

No offer to sell or license — Nothing in this document may be interpreted or construed as an offer to sell products that is open for acceptance or the grant, conveyance or implication of any license under any copyrights, patents or other industrial or intellectual property rights.

Export control — This document as well as the item(s) described herein may be subject to export control regulations. Export might require a prior authorization from competent authorities.

Non-automotive qualified products — Unless this data sheet expressly states that this specific Nexperia product is automotive qualified, the product is not suitable for automotive use. It is neither qualified nor tested in accordance with automotive testing or application requirements. Nexperia accepts no liability for inclusion and/or use of non-automotive qualified products in automotive equipment or applications.

In the event that customer uses the product for design-in and use in automotive applications to automotive specifications and standards, customer (a) shall use the product without Nexperia's warranty of the product for such automotive applications, use and specifications, and (b) whenever customer uses the product for automotive applications beyond Nexperia's specifications such use shall be solely at customer's own risk, and (c) customer fully indemnifies Nexperia for any liability, damages or failed product claims resulting from customer design and use of the product for automotive applications beyond Nexperia's standard warranty and Nexperia's product specifications.

Translations — A non-English (translated) version of a document is for reference only. The English version shall prevail in case of any discrepancy between the translated and English versions.

Trademarks

Notice: All referenced brands, product names, service names and trademarks are the property of their respective owners.

Contents

1. General description	1
2. Features and benefits	1
3. Ordering information	1
4. Functional diagram	2
5. Pinning information	3
5.1. Pinning.....	3
5.2. Pin description.....	4
6. Functional description	4
7. Limiting values	4
8. Recommended operating conditions	5
9. Static characteristics	5
10. Dynamic characteristics	6
10.1. Waveforms and test circuit.....	7
11. Package outline	9
12. Abbreviations	10
13. Revision history	10
14. Legal information	11

© Nexperia B.V. 2018. All rights reserved

For more information, please visit: <http://www.nexperia.com>
For sales office addresses, please send an email to: salesaddresses@nexperia.com
Date of release: 1 October 2018





Looking for pricing, stock, or lifecycle information?

Click below to explore more details on WIN SOURCE:

 [View 74LVT162374DGG,118 on WIN SOURCE](#)

 [NXP / Nexperia Information](#)

Optimize Your Supply Chain with WIN SOURCE Solutions

-  Global Sourcing Solution
-  Obsolete Management
-  Cost Control Management
-  Shortage Management
-  Alternative Solution
-  Excess Inventory Management