



**THE DATASHEET OF  
74LVCV2G66DC**



# 74LVCV2G66

## Overvoltage tolerant bilateral switch

Rev. 8 — 5 November 2018

Product data sheet

### 1. General description

The 74LVCV2G66 is a low-power, low-voltage, high-speed Si-gate CMOS device.

The 74LVCV2G66 provides two single pole single throw analog or digital switches. Each switch includes an overvoltage tolerant input/output terminal (pin nZ), an output/input terminal (pin nY) and low-power active HIGH enable input (pin nE).

The overvoltage tolerant switch terminals allow the switching of signals in excess of  $V_{CC}$ . The low-power enable input eliminates the necessity of using current limiting resistors in portable applications when using control logic signals much lower than  $V_{CC}$ . These inputs are also overvoltage tolerant.

### 2. Features and benefits

- Wide supply voltage range from 2.3 V to 5.5 V
- Ultra low-power operation
- Very low ON resistance:
  - 8.0  $\Omega$  (typical) at  $V_{CC} = 2.7$  V
  - 7.5  $\Omega$  (typical) at  $V_{CC} = 3.3$  V
  - 7.3  $\Omega$  (typical) at  $V_{CC} = 5.0$  V.
- 5 V tolerant input for interfacing with 5 V logic
- High noise immunity
- Switch handling capability of 32 mA
- CMOS low-power consumption
- Latch-up performance exceeds 250 mA
- Incorporates overvoltage tolerant analog switch technology
- Switch accepts voltages up to 5.5 V independent of  $V_{CC}$
- Multiple package options
- Specified from -40 °C to +85 °C and -40 °C to +125 °C

### 3. Ordering information

Table 1. Ordering information

Type number	Package			Version
	Temperature range	Name	Description	
74LVCV2G66DC	-40 °C to +125 °C	VSSOP8	plastic very thin shrink small outline package; 8 leads; body width 2.3 mm	SOT765-1
74LVCV2G66GT	-40 °C to +125 °C	XSON8	plastic extremely thin small outline package; no leads; 8 terminals; body 1 x 1.95 x 0.5 mm	SOT833-1
74LVCV2G66GM	-40 °C to +125 °C	XQFN8	plastic, extremely thin quad flat package; no leads; 8 terminals; body 1.6 x 1.6 x 0.5 mm	SOT902-2

## 4. Marking

Table 2. Marking codes

Type number	Marking code <sup>[1]</sup>
74LVCV2G66DC	Y66
74LVCV2G66GT	Y66
74LVCV2G66GM	Y66

[1] The pin 1 indicator is located on the lower left corner of the device, below the marking code.

## 5. Functional diagram

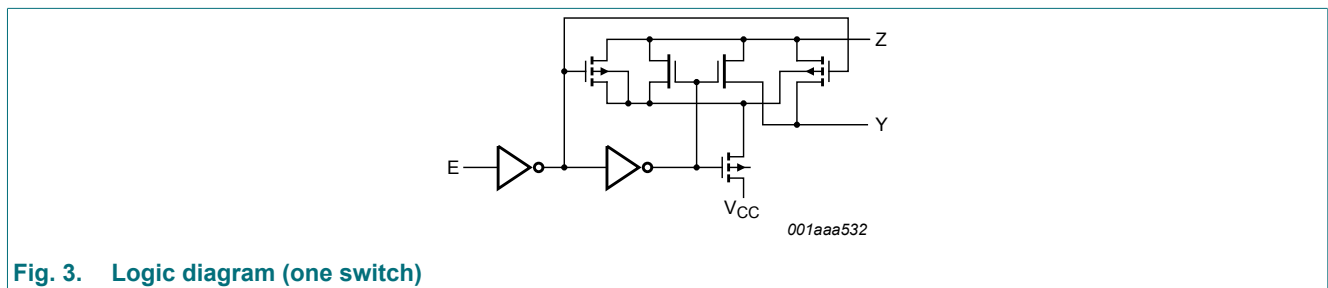
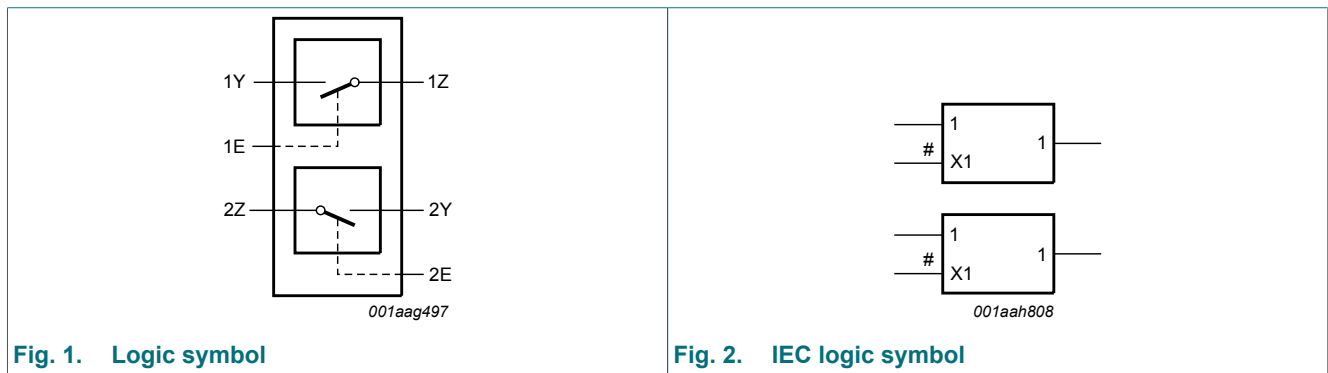

## 6. Pinning information

### 6.1. Pinning

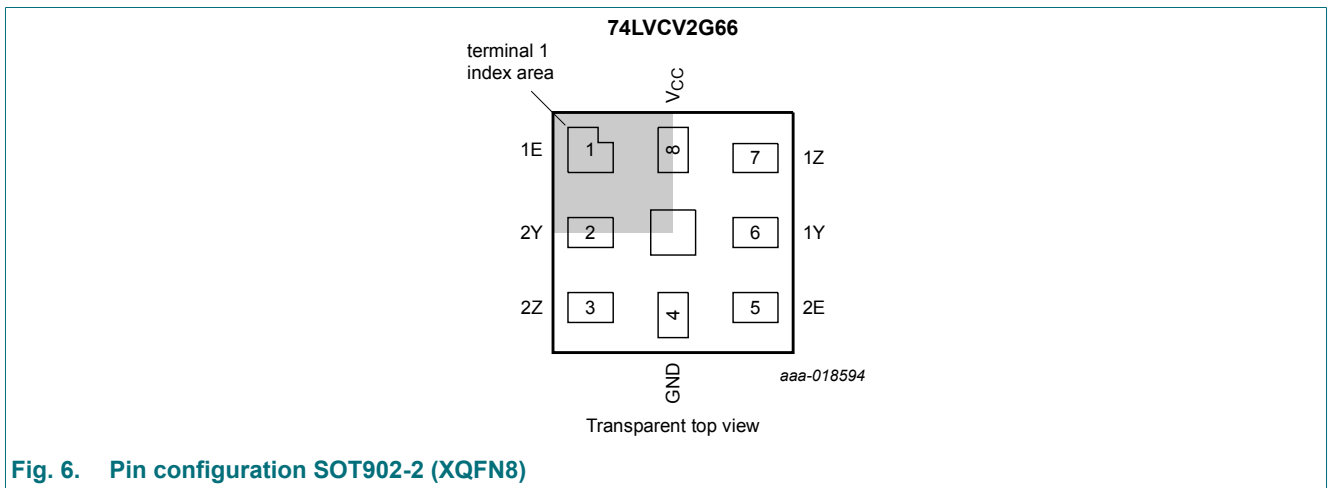
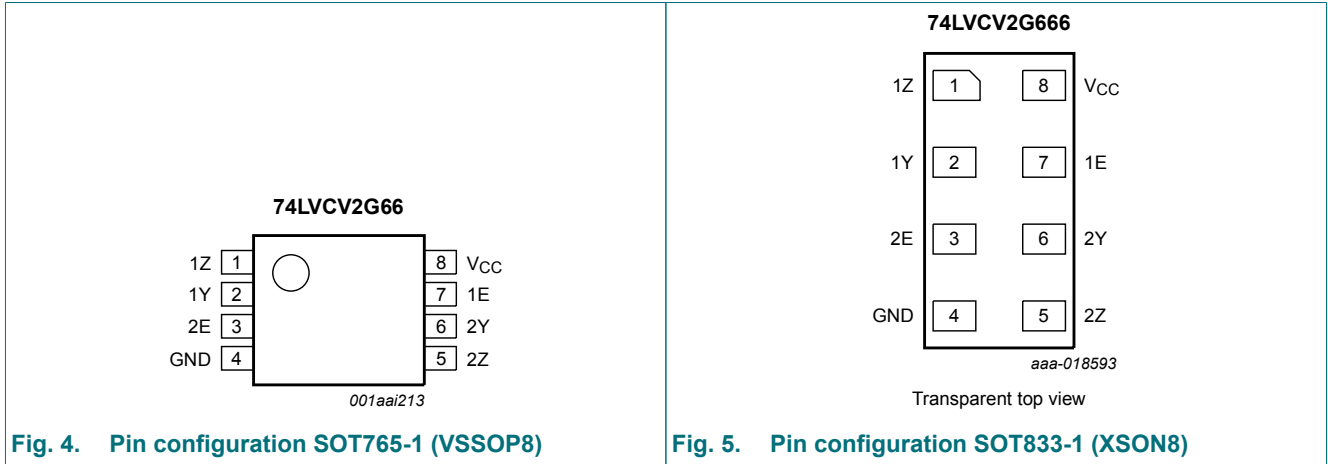

### 6.2. Pin description

Table 3. Pin description

Symbol	Pin		Description
	SOT765-1 and SOT833-1	SOT902-2	
1Z	1	7	independent input or output (overvoltage tolerant)
1Y	2	6	independent input or output
2E	3	5	enable input (active HIGH)
GND	4	4	ground (0 V)
2Z	5	3	independent input or output (overvoltage tolerant)
2Y	6	2	independent input or output
1E	7	1	enable input (active HIGH)
V <sub>CC</sub>	8	8	supply voltage

## 7. Functional description

**Table 4. Function table**

*H = HIGH voltage level; L = LOW voltage level.*

Input nE	Switch
L	OFF-state
H	ON-state

## 8. Limiting values

**Table 5. Limiting values**

*In accordance with the Absolute Maximum Rating System (IEC 60134). Voltages are referenced to GND (ground = 0 V).*

Symbol	Parameter	Conditions	Min	Max	Unit
$V_{CC}$	supply voltage		-0.5	+6.5	V
$V_I$	input voltage	[1]	-0.5	+6.5	V
$I_{IK}$	input clamping current	$V_I < -0.5 \text{ V}$ or $V_I > 6.5 \text{ V}$	-50	-	mA
$I_{SK}$	switch clamping current	$V_I < -0.5 \text{ V}$ or $V_I > 6.5 \text{ V}$	-	$\pm 50$	mA
$V_{SW}$	switch voltage	enable and disable mode	-0.5	+6.5	V
$I_{SW}$	switch current	$V_{SW} > -0.5 \text{ V}$ or $V_{SW} < 6.5 \text{ V}$	-	$\pm 50$	mA
$I_{CC}$	supply current		-	100	mA
$I_{GND}$	ground current		-100	-	mA
$T_{stg}$	storage temperature		-65	+150	°C
$P_{tot}$	total power dissipation	$T_{amb} = -40 \text{ °C}$ to $+125 \text{ °C}$ [2]	-	250	mW

[1] The input and output voltage ratings may be exceeded if the input and output current ratings are observed.

[2] For VSSOP8 package: above 110 °C, the value of  $P_{tot}$  derates linearly with 8 mW/K.

For XSON8 and XQFN8 packages: above 118 °C, the value of  $P_{tot}$  derates linearly with 7.8 mW/K.

## 9. Recommended operating conditions

**Table 6. Recommended operating conditions**

Symbol	Parameter	Conditions	Min	Typ	Max	Unit
$V_{CC}$	supply voltage		2.3	-	5.5	V
$V_I$	input voltage		0	-	5.5	V
$V_{SW}$	switch voltage	enable and disable mode [1]	0	-	5.5	V
$T_{amb}$	ambient temperature		-40	-	+125	°C
$\Delta t/\Delta V$	input transition rise and fall rate	$V_{CC} = 2.3 \text{ V}$ to $2.7 \text{ V}$ [2]	-	-	20	ns/V
		$V_{CC} = 2.7 \text{ V}$ to $5.5 \text{ V}$ [2]	-	-	10	ns/V

[1] To avoid sinking GND current from terminal nZ when switch current flows in terminal nY, the voltage drop across the bidirectional switch must not exceed 0.4 V. If the switch current flows into terminal nZ, no GND current flows from terminal nY. In this case, there is no limit for the voltage drop across the switch.

[2] Applies to control signal levels.

## 10. Static characteristics

**Table 7. Static characteristics**

At recommended operating conditions; voltages are referenced to GND (ground = 0 V).

Symbol	Parameter	Conditions	-40 °C to +85 °C			-40 °C to +125 °C		Unit
			Min	Typ[1]	Max	Min	Max	
V <sub>IH</sub>	HIGH-level input voltage	V <sub>CC</sub> = 2.3 V to 2.7 V	0.6V <sub>CC</sub>	-	-	0.6V <sub>CC</sub>	-	V
		V <sub>CC</sub> = 3.0 V to 3.6 V	2.0	-	-	2.0	-	V
		V <sub>CC</sub> = 4.5 V to 5.5 V	0.55V <sub>CC</sub>	-	-	0.55V <sub>CC</sub>	-	V
V <sub>IL</sub>	LOW-level input voltage	V <sub>CC</sub> = 2.3 V to 2.7 V	-	-	0.1V <sub>CC</sub>	-	0.1V <sub>CC</sub>	V
		V <sub>CC</sub> = 3.0 V to 3.6 V	-	-	0.5	-	0.5	V
		V <sub>CC</sub> = 4.5 V to 5.5 V	-	-	0.15V <sub>CC</sub>	-	0.15V <sub>CC</sub>	V
I <sub>I</sub>	input leakage current	pin nE; V <sub>I</sub> = 5.5 V or GND; V <sub>CC</sub> = 0 V to 5.5 V	-	±0.1	±1	-	±1	µA
I <sub>S(OFF)</sub>	OFF-state leakage current	V <sub>CC</sub> = 2.3 V to 5.5 V; see Fig. 7	-	±0.1	±0.4	-	±1	µA
I <sub>S(ON)</sub>	ON-state leakage current	V <sub>CC</sub> = 2.3 V to 5.5 V; see Fig. 8	-	±0.1	±2	-	±4	µA
I <sub>CC</sub>	supply current	V <sub>I</sub> = 5.5 V or GND; V <sub>SW</sub> = GND or V <sub>CC</sub> ; V <sub>CC</sub> = 2.3 V to 5.5 V	-	0.1	4	-	4	µA
ΔI <sub>CC</sub>	additional supply current	pin nE; V <sub>I</sub> = V <sub>CC</sub> - 0.6 V; V <sub>SW</sub> = GND or V <sub>CC</sub> ; V <sub>CC</sub> = 3.0 V to 5.5 V	-	0.1	5	-	5	µA
C <sub>I</sub>	input capacitance		-	2.5	-	-	-	pF
C <sub>S(OFF)</sub>	OFF-state capacitance		-	8.0	-	-	-	pF
C <sub>S(ON)</sub>	ON-state capacitance		-	16	-	-	-	pF

- [1] All typical values are measured at T<sub>amb</sub> = 25 °C.
- [2] These typical values are measured at V<sub>CC</sub> = 3.3 V.
- [3] For overvoltage signals (V<sub>SW</sub> > V<sub>CC</sub>), the condition V<sub>V</sub> < V<sub>Z</sub> must be observed.

### 10.1. Test circuits

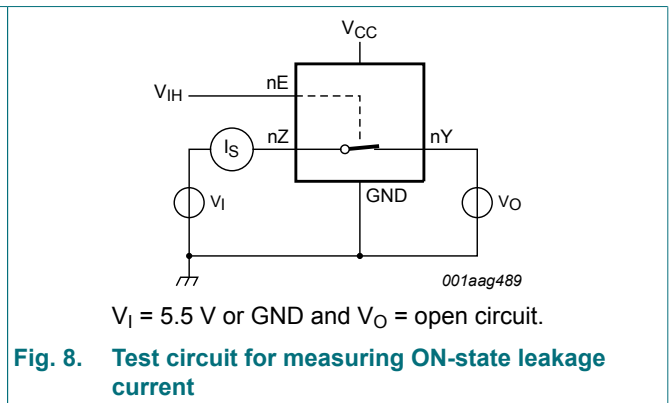
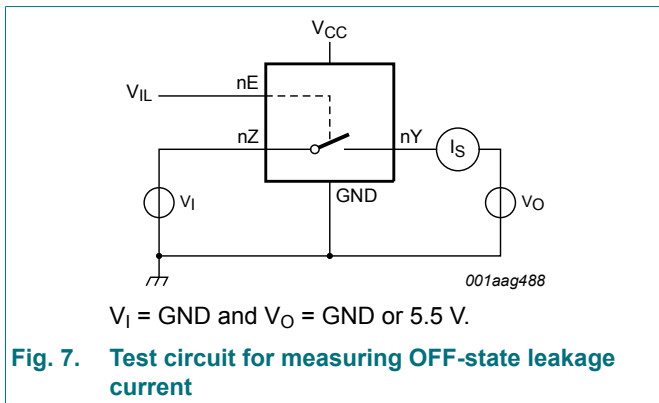

## 10.2. ON resistance

**Table 8. Resistance  $R_{ON}$**

At recommended operating conditions; voltages are referenced to GND (ground 0 V); for graphs see [Fig. 10](#) and [Fig. 11](#).

Symbol	Parameter	Conditions	-40 °C to +85 °C			-40 °C to +125 °C		Unit
			Min	Typ[1]	Max	Min	Max	
$R_{ON(peak)}$	ON resistance (peak)	$V_{SW} = GND$ to $V_{CC}$ ; $V_I = V_{IH}$ ; see <a href="#">Fig. 9</a>						
		$I_{SW} = 8$ mA; $V_{CC} = 2.3$ V to 2.7 V	-	13	30	-	30	$\Omega$
		$I_{SW} = 12$ mA; $V_{CC} = 2.7$ V	-	10	25	-	25	$\Omega$
		$I_{SW} = 24$ mA; $V_{CC} = 3.0$ V to 3.6 V	-	8.3	20	-	20	$\Omega$
		$I_{SW} = 32$ mA; $V_{CC} = 4.5$ V to 5.5 V	-	7.4	15	-	15	$\Omega$
$R_{ON(rail)}$	ON resistance (rail)	$V_{SW} = GND$ ; $V_I = V_{IH}$ ; see <a href="#">Fig. 9</a>						
		$I_{SW} = 8$ mA; $V_{CC} = 2.3$ V to 2.7 V	-	8.5	20	-	20	$\Omega$
		$I_{SW} = 12$ mA; $V_{CC} = 2.7$ V	-	8.0	18	-	18	$\Omega$
		$I_{SW} = 24$ mA; $V_{CC} = 3.0$ V to 3.6 V	-	7.5	15	-	15	$\Omega$
		$I_{SW} = 32$ mA; $V_{CC} = 4.5$ V to 5.5 V	-	7.3	10	-	10	$\Omega$
		$V_{SW} = V_{CC}$ ; $V_I = V_{IH}$						
		$I_{SW} = 8$ mA; $V_{CC} = 2.3$ V to 2.7 V	-	8.5	20	-	20	$\Omega$
		$I_{SW} = 12$ mA; $V_{CC} = 2.7$ V	-	7.2	18	-	18	$\Omega$
		$I_{SW} = 24$ mA; $V_{CC} = 3.0$ V to 3.6 V	-	6.5	15	-	15	$\Omega$
		$I_{SW} = 32$ mA; $V_{CC} = 4.5$ V to 5.5 V	-	5.7	10	-	10	$\Omega$
$R_{ON(flat)}$	ON resistance (flatness)	$V_{SW} = GND$ to $V_{CC}$ ; $V_I = V_{IH}$ [2]						
		$I_{SW} = 8$ mA; $V_{CC} = 2.5$ V	-	17	-	-	-	$\Omega$
		$I_{SW} = 12$ mA; $V_{CC} = 2.7$ V	-	10	-	-	-	$\Omega$
		$I_{SW} = 24$ mA; $V_{CC} = 3.3$ V	-	5	-	-	-	$\Omega$
		$I_{SW} = 32$ mA; $V_{CC} = 5.0$ V	-	3	-	-	-	$\Omega$

[1] All typical values are measured at  $T_{amb} = 25$  °C and nominal  $V_{CC}$ .

[2] Flatness is defined as the difference between the maximum and minimum value of ON resistance measured at identical  $V_{CC}$  and temperature.

10.3. ON resistance test circuit and graphs

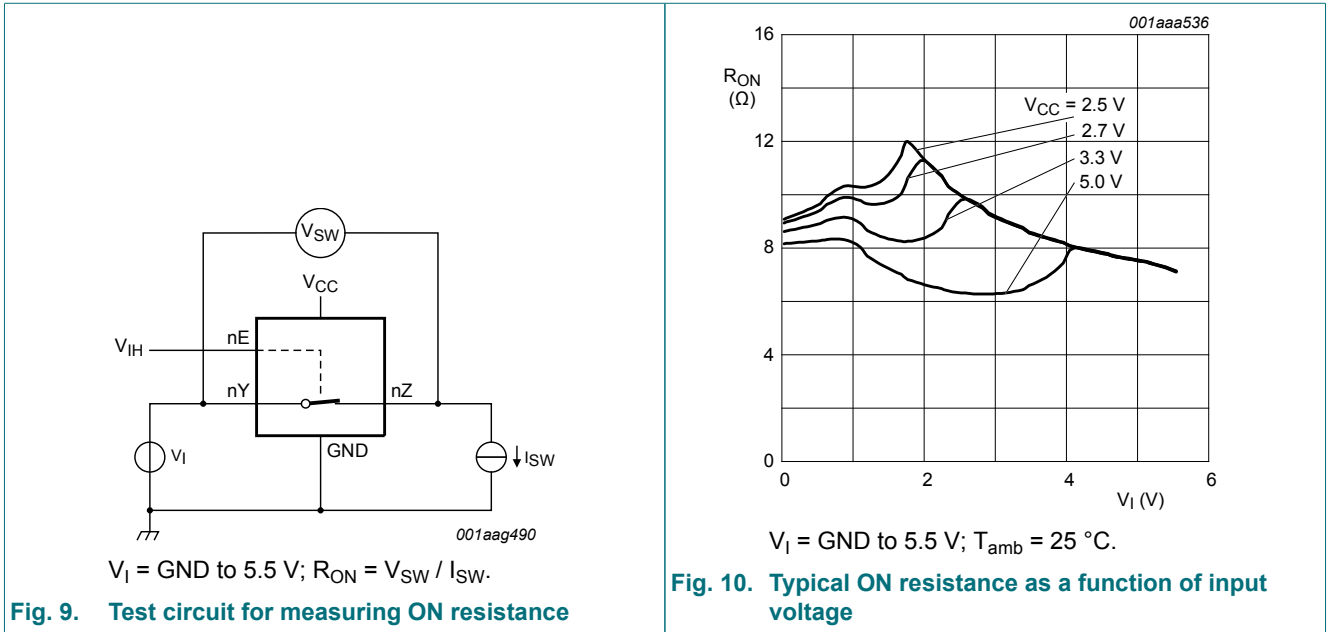

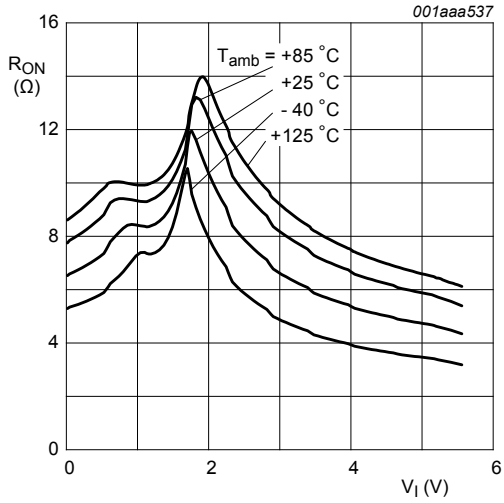

a.  $V_{CC} = 2.5 \text{ V}$

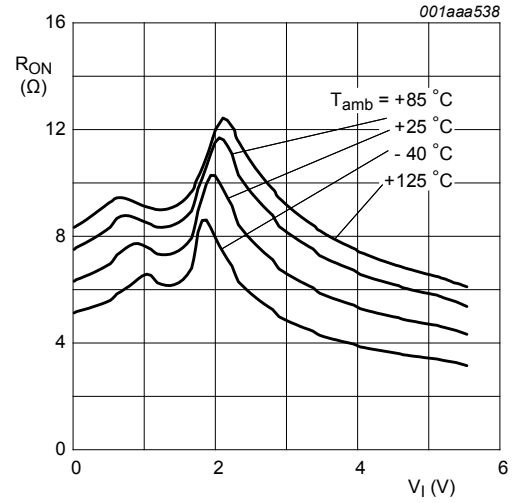

b.  $V_{CC} = 2.7 \text{ V}$

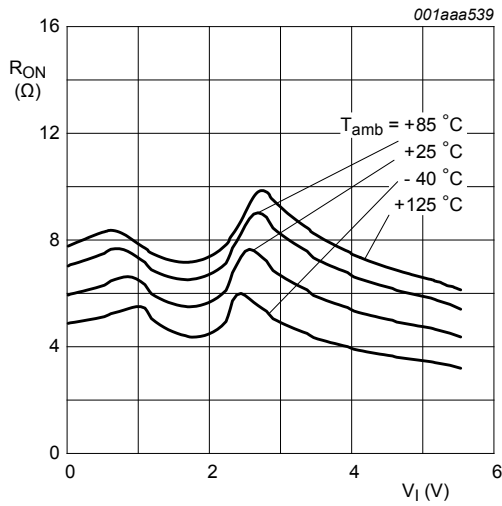

c.  $V_{CC} = 3.3 \text{ V}$

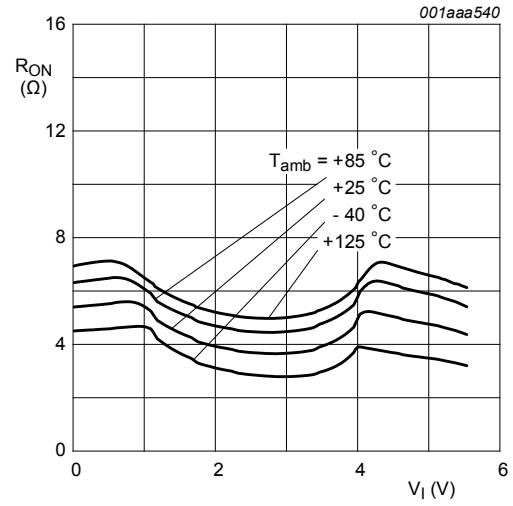

d.  $V_{CC} = 5.0 \text{ V}$

Fig. 11. ON resistance as a function of input voltage at various supply voltages

## 11. Dynamic characteristics

**Table 9. Dynamic characteristics**

At recommended operating conditions; voltages are referenced to GND (ground = 0 V); for test circuit, see Fig. 14.

Symbol	Parameter	Conditions	-40 °C to +85 °C			-40 °C to +125 °C		Unit
			Min	Typ[1]	Max	Min	Max	
t <sub>pd</sub>	propagation delay	nY to nZ or nZ to nY; see Fig. 12 [2][3]						
		V <sub>CC</sub> = 2.3 V to 2.7 V	-	0.4	1.2	-	2.0	ns
		V <sub>CC</sub> = 2.7 V	-	0.4	1.0	-	1.5	ns
		V <sub>CC</sub> = 3.0 V to 3.6 V	-	0.3	0.8	-	1.5	ns
		V <sub>CC</sub> = 4.5 V to 5.5 V	-	0.2	0.6	-	1.0	ns
t <sub>en</sub>	enable time	nE to nY or nZ; see Fig. 13 [4]						
		V <sub>CC</sub> = 2.3 V to 2.7 V	1.0	4.7	12	1.0	15	ns
		V <sub>CC</sub> = 2.7 V	1.0	4.4	8.5	1.0	11	ns
		V <sub>CC</sub> = 3.0 V to 3.6 V	1.0	3.8	7.5	1.0	9.5	ns
		V <sub>CC</sub> = 4.5 V to 5.5 V	1.0	2.7	5.0	1.0	6.5	ns
t <sub>dis</sub>	disable time	nE to nY or nZ; see Fig. 13 [5]						
		V <sub>CC</sub> = 2.3 V to 2.7 V	1.0	6.0	16	1.0	20	ns
		V <sub>CC</sub> = 2.7 V	1.0	7.9	15	1.0	19	ns
		V <sub>CC</sub> = 3.0 V to 3.6 V	1.0	6.5	13.5	1.0	17	ns
		V <sub>CC</sub> = 4.5 V to 5.5 V	1.0	4.4	9.0	1.0	11.5	ns
C <sub>PD</sub>	power dissipation capacitance	C <sub>L</sub> = 50 pF; f <sub>i</sub> = 10 MHz; V <sub>I</sub> = GND to 5.5 V[6]						
		V <sub>CC</sub> = 2.5 V	-	9.7	-	-	-	pF
		V <sub>CC</sub> = 3.3 V	-	10.3	-	-	-	pF
		V <sub>CC</sub> = 5.0 V	-	11.3	-	-	-	pF

[1] Typical values are measured at T<sub>amb</sub> = 25 °C and nominal V<sub>CC</sub>.

[2] t<sub>pd</sub> is the same as t<sub>PLH</sub> and t<sub>PHL</sub>.

[3] Propagation delay is the calculated RC time constant of the typical ON resistance of the switch and the specified capacitance when driven by an ideal voltage source (zero output impedance).

[4] t<sub>en</sub> is the same as t<sub>PZH</sub> and t<sub>PZL</sub>.

[5] t<sub>dis</sub> is the same as t<sub>PLZ</sub> and t<sub>PHZ</sub>.

[6] C<sub>PD</sub> is used to determine the dynamic power dissipation (P<sub>D</sub> in μW).

$P_D = C_{PD} \times V_{CC}^2 \times f_i \times N + \sum \{(C_L + C_{S(ON)}) \times V_{CC}^2 \times f_o\}$  where:

f<sub>i</sub> = input frequency in MHz;

f<sub>o</sub> = output frequency in MHz;

C<sub>L</sub> = output load capacitance in pF;

C<sub>S(ON)</sub> = maximum ON-state switch capacitance in pF;

V<sub>CC</sub> = supply voltage in V;

N = number of inputs switching;

$\sum \{(C_L + C_{S(ON)}) \times V_{CC}^2 \times f_o\}$  = sum of the outputs.

11.1. Waveforms and test circuit

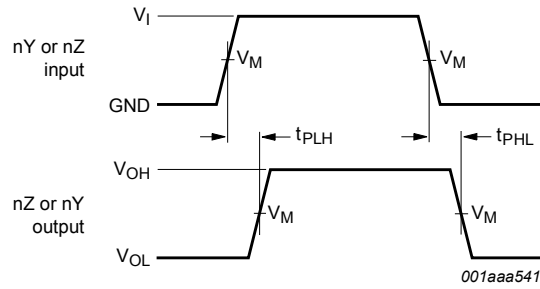

Measurement points are given in Table 10.

Logic levels:  $V_{OL}$  and  $V_{OH}$  are typical output voltage levels that occur with the output load.

Fig. 12. Input (nY or nZ) to output (nZ or nY) propagation delays

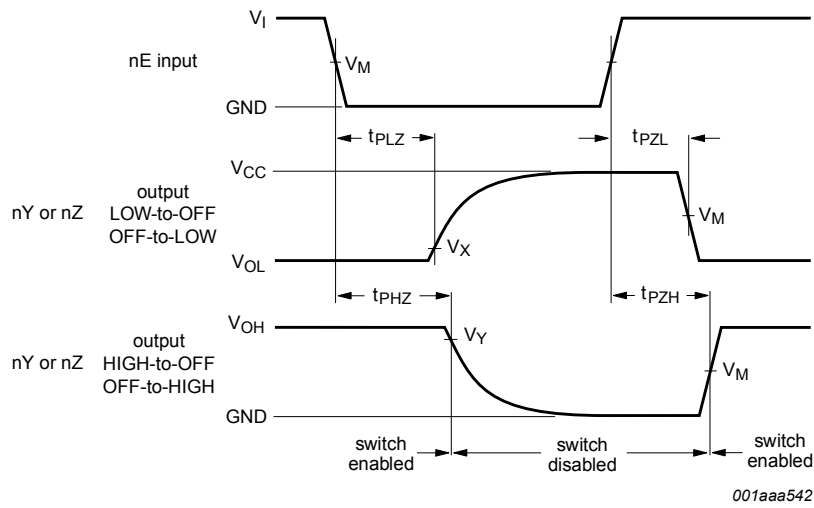

Measurement points are given in Table 10.

Logic levels:  $V_{OL}$  and  $V_{OH}$  are typical output voltage levels that occur with the output load.

Fig. 13. Enable and disable times

Table 10. Measurement points

Supply voltage	Input	Output		
$V_{CC}$	$V_M$	$V_M$	$V_X$	$V_Y$
2.3 V to 2.7 V	$0.5V_{CC}$	$0.5V_{CC}$	$V_{OL} + 0.1V_{CC}$	$V_{OH} - 0.1V_{CC}$
2.7 V	1.5 V	1.5 V	$V_{OL} + 0.3 V$	$V_{OH} - 0.3 V$
3.0 V to 3.6 V	1.5 V	1.5 V	$V_{OL} + 0.3 V$	$V_{OH} - 0.3 V$
4.5 V to 5.5 V	$0.5V_{CC}$	$0.5V_{CC}$	$V_{OL} + 0.3 V$	$V_{OH} - 0.3 V$

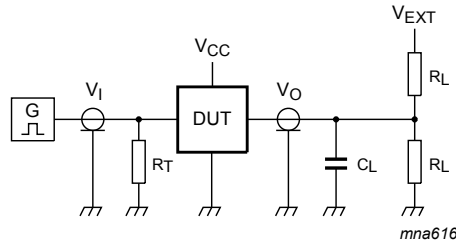

Test data is given in [Table 11](#).

Definitions test circuit:

$R_T$  = Termination resistance should be equal to output impedance  $Z_o$  of the pulse generator.

$C_L$  = Load capacitance including jig and probe capacitance.

$R_L$  = Load resistance.

$V_{EXT}$  = External voltage for measuring switching times.

**Fig. 14. Test circuit for measuring switching times**

**Table 11. Test data**

Supply voltage	Input		Load		$V_{EXT}$		
$V_{CC}$	$V_I$	$t_r, t_f$	$C_L$	$R_L$	$t_{PLH}, t_{PHL}$	$t_{PZH}, t_{PHZ}$	$t_{PZL}, t_{PLZ}$
2.3 V to 2.7 V	$V_{CC}$	$\leq 2.0$ ns	30 pF	500 $\Omega$	open	GND	$2V_{CC}$
2.7 V	2.7 V	$\leq 2.5$ ns	50 pF	500 $\Omega$	open	GND	6.0 V
3.0 V to 3.6 V	2.7 V	$\leq 2.5$ ns	50 pF	500 $\Omega$	open	GND	6.0 V
4.5 V to 5.5 V	$V_{CC}$	$\leq 2.5$ ns	50 pF	500 $\Omega$	open	GND	$2V_{CC}$

## 11.2. Additional dynamic characteristics

**Table 12. Additional dynamic characteristics**

At recommended operating conditions; voltages are referenced to GND (ground = 0 V);  $T_{amb} = 25$  °C.

Symbol	Parameter	Conditions	Min	Typ	Max	Unit
THD	total harmonic distortion	$f_i = 1$ kHz; $R_L = 10$ k $\Omega$ ; $C_L = 50$ pF; see <a href="#">Fig. 15</a>				
		$V_{CC} = 2.3$ V	-	0.42	-	%
		$V_{CC} = 3.0$ V	-	0.36	-	%
		$V_{CC} = 4.5$ V	-	0.47	-	%
		$f_i = 10$ kHz; $R_L = 10$ k $\Omega$ ; $C_L = 50$ pF; see <a href="#">Fig. 15</a>				
		$V_{CC} = 2.3$ V	-	0.11	-	%
		$V_{CC} = 3.0$ V	-	0.07	-	%
$f_{(-3dB)}$	-3 dB frequency response	$R_L = 600$ $\Omega$ ; $C_L = 50$ pF; see <a href="#">Fig. 16</a>				
		$V_{CC} = 2.3$ V	-	160	-	MHz
		$V_{CC} = 3.0$ V	-	200	-	MHz
		$V_{CC} = 4.5$ V	-	210	-	MHz
		$R_L = 50$ $\Omega$ ; $C_L = 5$ pF; see <a href="#">Fig. 16</a>				
		$V_{CC} = 2.3$ V	-	180	-	MHz
		$V_{CC} = 3.0$ V	-	180	-	MHz
$V_{CC} = 4.5$ V	-	180	-	MHz		

Symbol	Parameter	Conditions	Min	Typ	Max	Unit
$\alpha_{iso}$	isolation (OFF-state)	$R_L = 600 \Omega$ ; $C_L = 50 \text{ pF}$ ; $f_i = 1 \text{ MHz}$ ; see Fig. 17				
		$V_{CC} = 2.3 \text{ V}$	-	-65	-	dB
		$V_{CC} = 3.0 \text{ V}$	-	-65	-	dB
		$V_{CC} = 4.5 \text{ V}$	-	-62	-	dB
		$R_L = 50 \Omega$ ; $C_L = 5 \text{ pF}$ ; $f_i = 1 \text{ MHz}$ ; see Fig. 17				
		$V_{CC} = 2.3 \text{ V}$	-	-37	-	dB
		$V_{CC} = 3.0 \text{ V}$	-	-36	-	dB
$V_{CC} = 4.5 \text{ V}$	-	-36	-	dB		
$V_{ct}$	crosstalk voltage	between digital inputs and switch; $R_L = 600 \Omega$ ; $C_L = 50 \text{ pF}$ ; $f_i = 1 \text{ MHz}$ ; $t_r = t_f = 2 \text{ ns}$ ; see Fig. 18				
		$V_{CC} = 2.3 \text{ V}$	-	91	-	mV
		$V_{CC} = 3.0 \text{ V}$	-	119	-	mV
		$V_{CC} = 4.5 \text{ V}$	-	205	-	mV
Xtalk	crosstalk	between switches; $R_L = 600 \Omega$ ; $C_L = 50 \text{ pF}$ ; $f_i = 1 \text{ MHz}$ ; see Fig. 19				
		$V_{CC} = 2.3 \text{ V}$	-	-56	-	dB
		$V_{CC} = 3.0 \text{ V}$	-	-55	-	dB
		$V_{CC} = 4.5 \text{ V}$	-	-55	-	dB
		between switches; $R_L = 50 \Omega$ ; $C_L = 5 \text{ pF}$ ; $f_i = 1 \text{ MHz}$ ; see Fig. 19				
		$V_{CC} = 2.3 \text{ V}$	-	-29	-	dB
		$V_{CC} = 3.0 \text{ V}$	-	-28	-	dB
$V_{CC} = 4.5 \text{ V}$	-	-28	-	dB		
$Q_{inj}$	charge injection	$C_L = 0.1 \text{ nF}$ ; $V_{gen} = 0 \text{ V}$ ; $R_{gen} = 0 \Omega$ ; $f_i = 1 \text{ MHz}$ ; $R_L = 1 \text{ M}\Omega$ ; see Fig. 20				
		$V_{CC} = 2.5 \text{ V}$	-	< 0.003	-	pC
		$V_{CC} = 3.3 \text{ V}$	-	0.003	-	pC
		$V_{CC} = 4.5 \text{ V}$	-	0.0035	-	pC
		$V_{CC} = 5.5 \text{ V}$	-	0.0035	-	pC

### 11.3. Test circuits

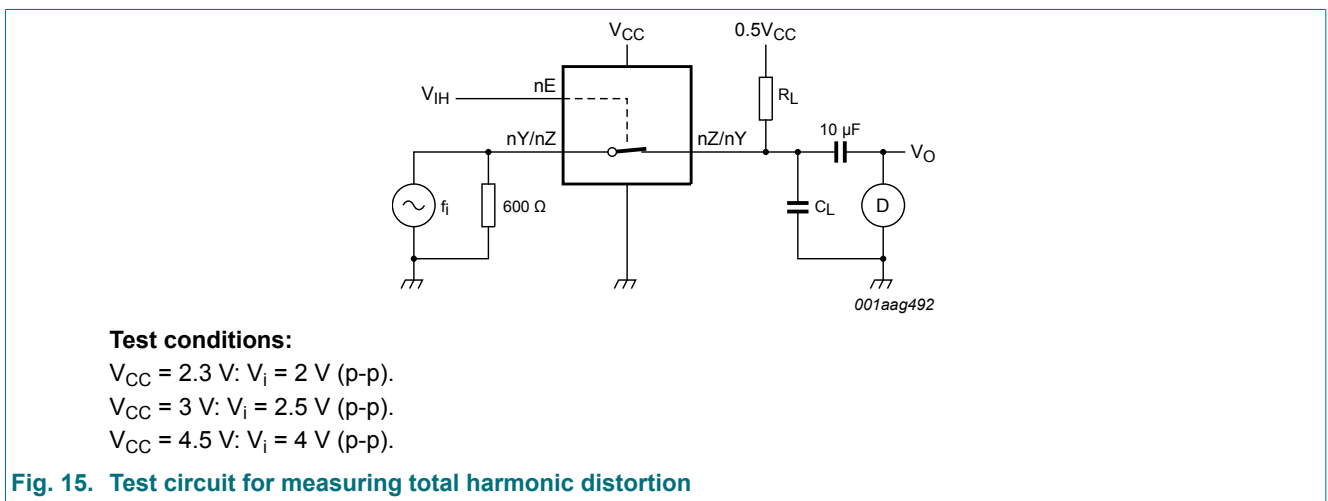

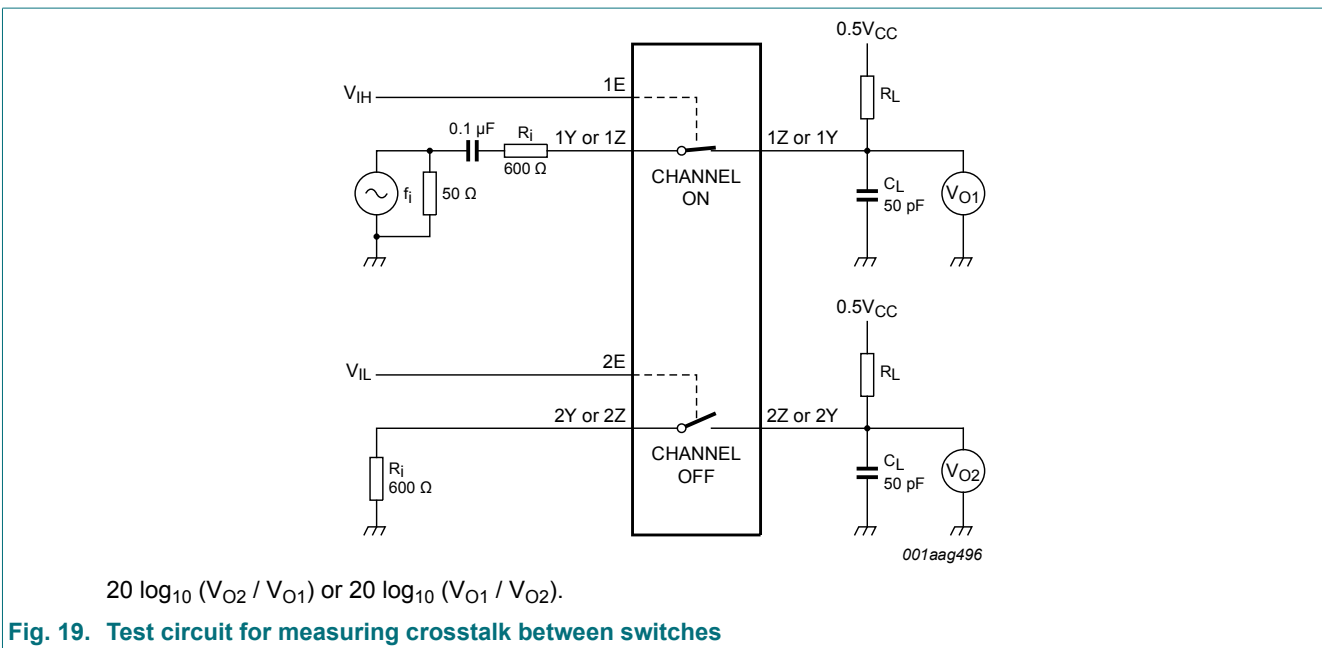
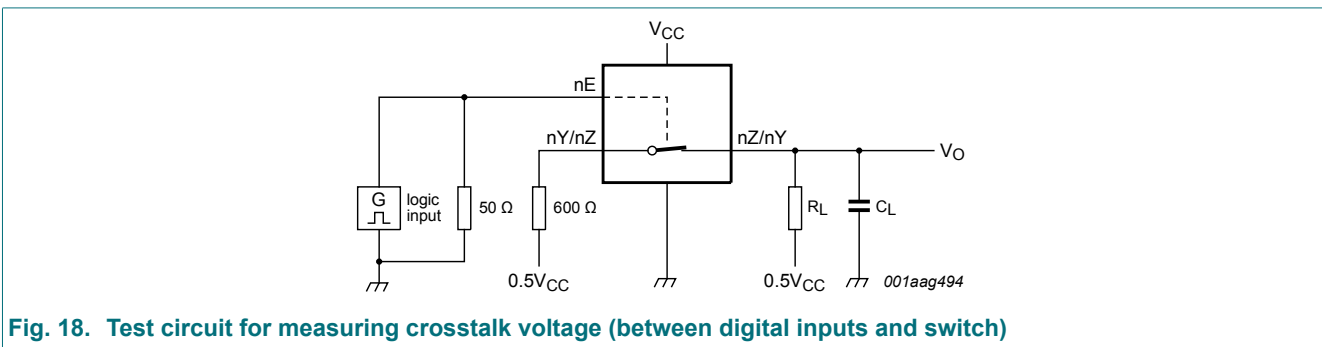
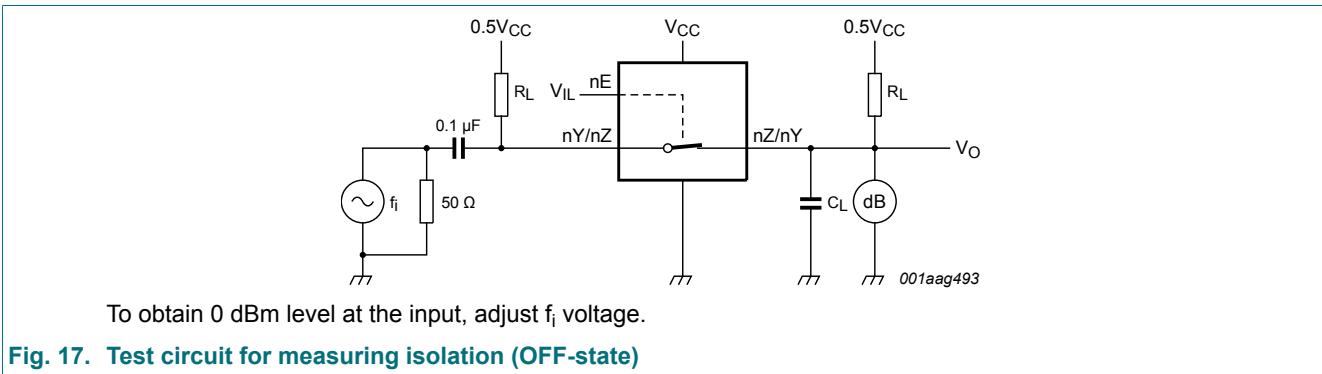
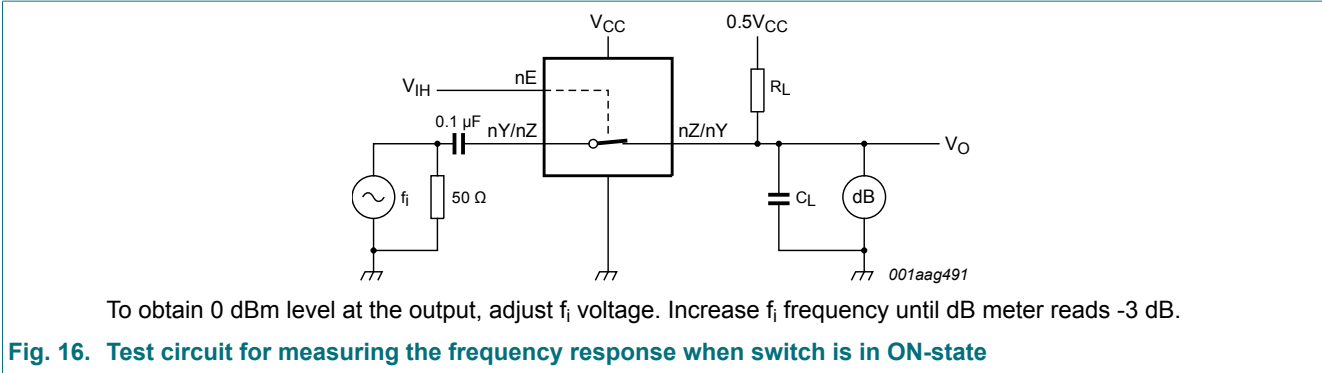

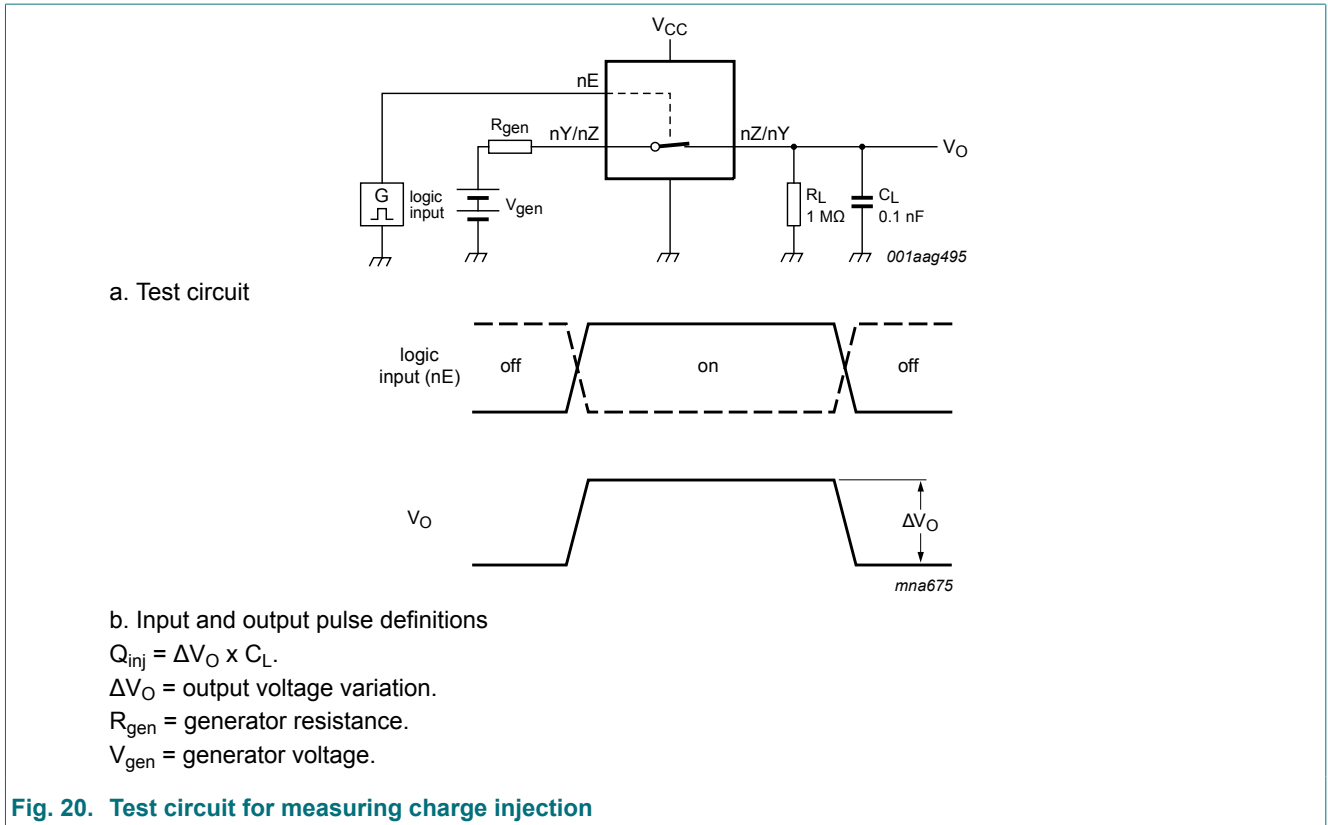

Fig. 20. Test circuit for measuring charge injection

## 12. Application information

The 74LVCV2G66 is used to reduce component count and footprint in low-power portable applications.

Typical '66' devices do not have low-power enable inputs causing a high  $\Delta I_{CC}$ . To reduce power consumption in portable (battery) applications, a current limiting resistor is used. (see Fig. 21a). The low-power enable inputs of the 74LVCV2G66 have much lower  $\Delta I_{CC}$ , eliminating the necessity of the current limiting resistor (see Fig. 21b).

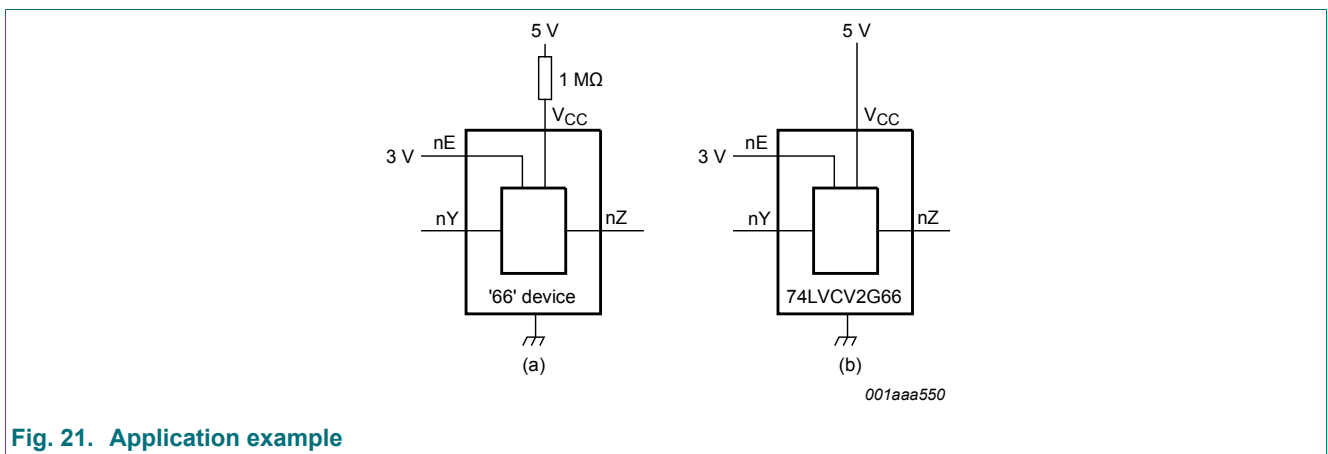
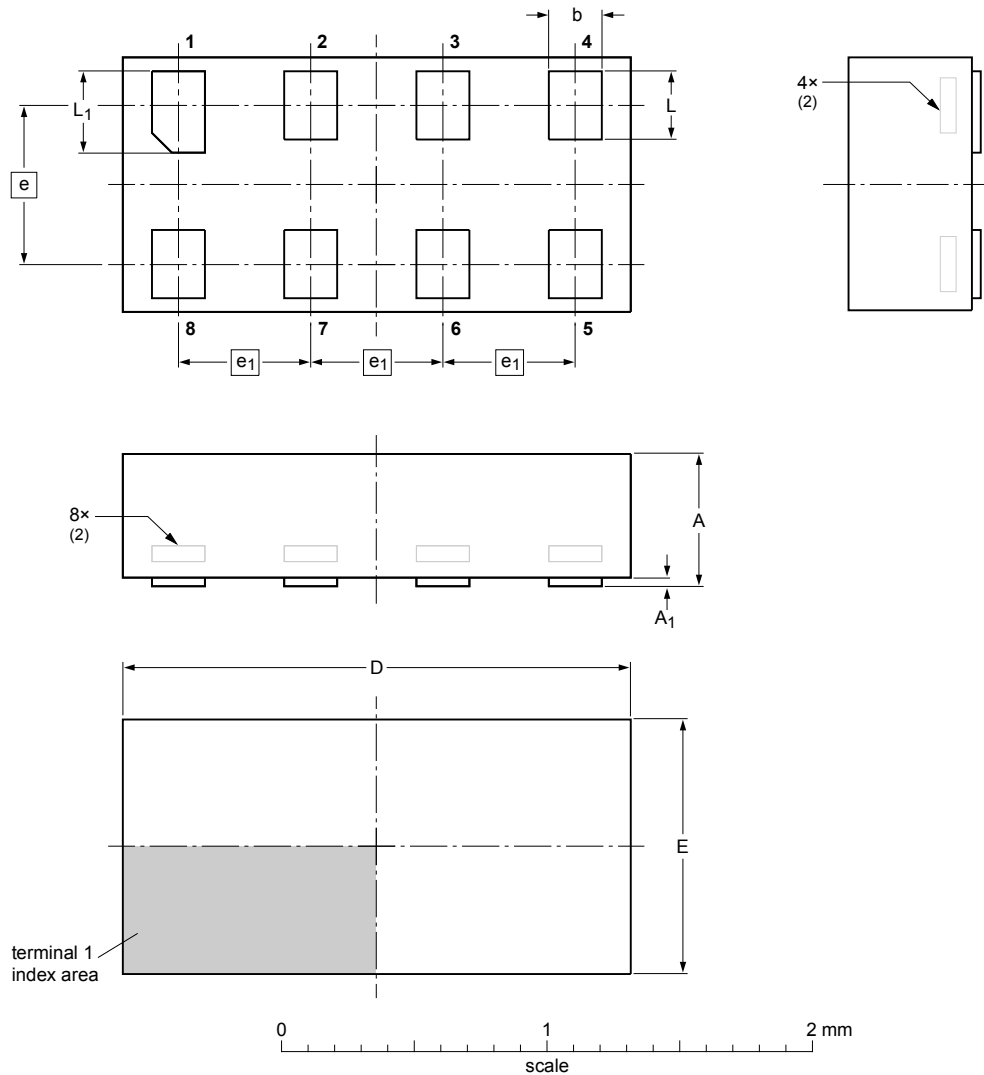

Fig. 21. Application example



XSON8: plastic extremely thin small outline package; no leads; 8 terminals; body 1 x 1.95 x 0.5 mm

SOT833-1



**DIMENSIONS** (mm are the original dimensions)

UNIT	A <sup>(1)</sup> max	A <sub>1</sub> max	b	D	E	e	e <sub>1</sub>	L	L <sub>1</sub>
mm	0.5	0.04	0.25 0.17	2.0 1.9	1.05 0.95	0.6	0.5	0.35 0.27	0.40 0.32

**Notes**

- Including plating thickness.
- Can be visible in some manufacturing processes.

OUTLINE VERSION	REFERENCES			EUROPEAN PROJECTION	ISSUE DATE
	IEC	JEDEC	JEITA		
SOT833-1	---	MO-252	---		-07-11-14- 07-12-07

**Fig. 23. Package outline SOT833-1 (XSON8)**

**XQFN8: plastic, extremely thin quad flat package; no leads;**  
**8 terminals; body 1.6 x 1.6 x 0.5 mm**

**SOT902-2**

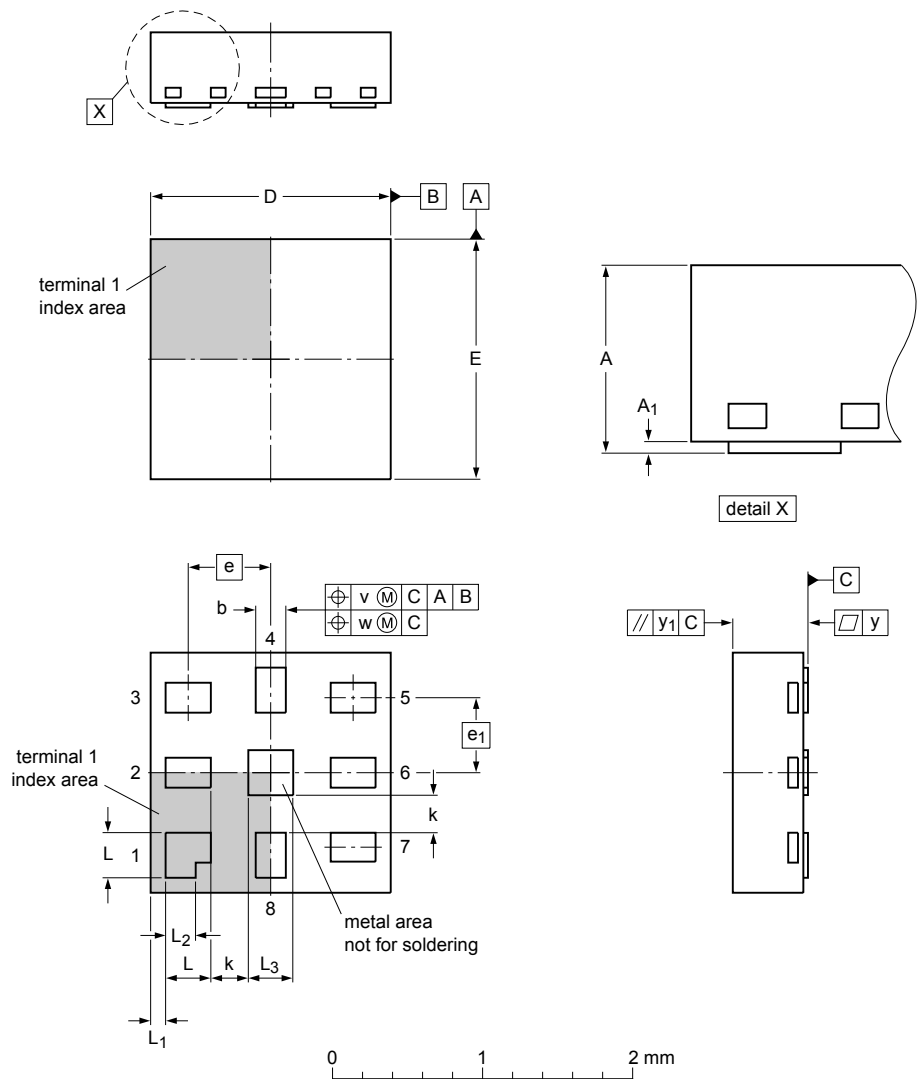

**Dimensions**

Unit <sup>(1)</sup>	A	A <sub>1</sub>	b	D	E	e	e <sub>1</sub>	k	L	L <sub>1</sub>	L <sub>2</sub>	L <sub>3</sub>	v	w	y	y <sub>1</sub>
max	0.5	0.05	0.25	1.65	1.65				0.35	0.15	0.25	0.35				
mm	nom		0.20	1.60	1.60	0.55	0.5		0.30	0.10	0.20	0.30	0.1	0.05	0.05	0.05
min		0.00	0.15	1.55	1.55			0.2	0.25	0.05	0.15	0.25				

**Note**

1. Plastic or metal protrusions of 0.075 mm maximum per side are not included.

sot902-2\_po

Outline version	References			European projection	Issue date
	IEC	JEDEC	JEITA		
SOT902-2	---	MO-255	---		16-07-14 16-11-08

**Fig. 24. Package outline SOT902-2 (XQFN8)**

## 14. Abbreviations

Table 13. Abbreviations

Acronym	Description
CMOS	Complementary Metal-Oxide Semiconductor
DUT	Device Under Test

## 15. Revision history

Table 14. Revision history

Document ID	Release date	Data sheet status	Change notice	Supersedes
74LVCV2G66 v.8	20181105	Product data sheet	-	74LVCV2G66 v.7
Modifications:	<ul style="list-style-type: none"> <li>The format of this data sheet has been redesigned to comply with the identity guidelines of Nexperia.</li> <li>Legal texts have been adapted to the new company name where appropriate.</li> <li>Type numbers 74LVCV2G66GD (SOT996-2/XSON8) removed.</li> </ul>			
74LVCV2G66 v.7	20161215	Product data sheet	-	74LVCV2G66 v.6
Modifications:	<ul style="list-style-type: none"> <li><a href="#">Table 7</a>: The maximum limits for leakage current and supply current have changed.</li> <li>Type number 74LVCV2G66DP (SOT505-2) removed.</li> </ul>			
74LVCV2G66 v.6	20150722	Product data sheet	-	74LVCV2G66 v.5
Modifications:	<ul style="list-style-type: none"> <li>Added type numbers 74LVCV2G66GT and 74LVCV2G66GM</li> </ul>			
74LVCV2G66 v.5	20130329	Product data sheet	-	74LVCV2G66 v.4
Modifications:	<ul style="list-style-type: none"> <li>For type number 74LVCV2G66GD XSON8U has changed to XSON8.</li> </ul>			
74LVCV2G66 v.4	20111122	Product data sheet	-	74LVCV2G66 v.3
Modifications:	<ul style="list-style-type: none"> <li>Legal pages updated.</li> </ul>			
74LVCV2G66 v.3	20100616	Product data sheet	-	74LVCV2G66 v.2
74LVCV2G66 v.2	20080703	Product data sheet	-	74LVCV2G66 v.1
74LVCV2G66 v.1	20040402	Product data sheet	-	-

## 16. Legal information

### Data sheet status

Document status [1][2]	Product status [3]	Definition
Objective [short] data sheet	Development	This document contains data from the objective specification for product development.
Preliminary [short] data sheet	Qualification	This document contains data from the preliminary specification.
Product [short] data sheet	Production	This document contains the product specification.

- [1] Please consult the most recently issued document before initiating or completing a design.
- [2] The term 'short data sheet' is explained in section "Definitions".
- [3] The product status of device(s) described in this document may have changed since this document was published and may differ in case of multiple devices. The latest product status information is available on the internet at <https://www.nexperia.com>.

### Definitions

**Draft** — The document is a draft version only. The content is still under internal review and subject to formal approval, which may result in modifications or additions. Nexperia does not give any representations or warranties as to the accuracy or completeness of information included herein and shall have no liability for the consequences of use of such information.

**Short data sheet** — A short data sheet is an extract from a full data sheet with the same product type number(s) and title. A short data sheet is intended for quick reference only and should not be relied upon to contain detailed and full information. For detailed and full information see the relevant full data sheet, which is available on request via the local Nexperia sales office. In case of any inconsistency or conflict with the short data sheet, the full data sheet shall prevail.

**Product specification** — The information and data provided in a Product data sheet shall define the specification of the product as agreed between Nexperia and its customer, unless Nexperia and customer have explicitly agreed otherwise in writing. In no event however, shall an agreement be valid in which the Nexperia product is deemed to offer functions and qualities beyond those described in the Product data sheet.

### Disclaimers

**Limited warranty and liability** — Information in this document is believed to be accurate and reliable. However, Nexperia does not give any representations or warranties, expressed or implied, as to the accuracy or completeness of such information and shall have no liability for the consequences of use of such information. Nexperia takes no responsibility for the content in this document if provided by an information source outside of Nexperia.

In no event shall Nexperia be liable for any indirect, incidental, punitive, special or consequential damages (including - without limitation - lost profits, lost savings, business interruption, costs related to the removal or replacement of any products or rework charges) whether or not such damages are based on tort (including negligence), warranty, breach of contract or any other legal theory.

Notwithstanding any damages that customer might incur for any reason whatsoever, Nexperia's aggregate and cumulative liability towards customer for the products described herein shall be limited in accordance with the Terms and conditions of commercial sale of Nexperia.

**Right to make changes** — Nexperia reserves the right to make changes to information published in this document, including without limitation specifications and product descriptions, at any time and without notice. This document supersedes and replaces all information supplied prior to the publication hereof.

**Suitability for use** — Nexperia products are not designed, authorized or warranted to be suitable for use in life support, life-critical or safety-critical systems or equipment, nor in applications where failure or malfunction of an Nexperia product can reasonably be expected to result in personal

injury, death or severe property or environmental damage. Nexperia and its suppliers accept no liability for inclusion and/or use of Nexperia products in such equipment or applications and therefore such inclusion and/or use is at the customer's own risk.

**Quick reference data** — The Quick reference data is an extract of the product data given in the Limiting values and Characteristics sections of this document, and as such is not complete, exhaustive or legally binding.

**Applications** — Applications that are described herein for any of these products are for illustrative purposes only. Nexperia makes no representation or warranty that such applications will be suitable for the specified use without further testing or modification.

Customers are responsible for the design and operation of their applications and products using Nexperia products, and Nexperia accepts no liability for any assistance with applications or customer product design. It is customer's sole responsibility to determine whether the Nexperia product is suitable and fit for the customer's applications and products planned, as well as for the planned application and use of customer's third party customer(s). Customers should provide appropriate design and operating safeguards to minimize the risks associated with their applications and products.

Nexperia does not accept any liability related to any default, damage, costs or problem which is based on any weakness or default in the customer's applications or products, or the application or use by customer's third party customer(s). Customer is responsible for doing all necessary testing for the customer's applications and products using Nexperia products in order to avoid a default of the applications and the products or of the application or use by customer's third party customer(s). Nexperia does not accept any liability in this respect.

**Limiting values** — Stress above one or more limiting values (as defined in the Absolute Maximum Ratings System of IEC 60134) will cause permanent damage to the device. Limiting values are stress ratings only and (proper) operation of the device at these or any other conditions above those given in the Recommended operating conditions section (if present) or the Characteristics sections of this document is not warranted. Constant or repeated exposure to limiting values will permanently and irreversibly affect the quality and reliability of the device.

**Terms and conditions of commercial sale** — Nexperia products are sold subject to the general terms and conditions of commercial sale, as published at <http://www.nexperia.com/profile/terms>, unless otherwise agreed in a valid written individual agreement. In case an individual agreement is concluded only the terms and conditions of the respective agreement shall apply. Nexperia hereby expressly objects to applying the customer's general terms and conditions with regard to the purchase of Nexperia products by customer.

**No offer to sell or license** — Nothing in this document may be interpreted or construed as an offer to sell products that is open for acceptance or the grant, conveyance or implication of any license under any copyrights, patents or other industrial or intellectual property rights.

**Export control** — This document as well as the item(s) described herein may be subject to export control regulations. Export might require a prior authorization from competent authorities.

**Non-automotive qualified products** — Unless this data sheet expressly states that this specific Nexperia product is automotive qualified, the product is not suitable for automotive use. It is neither qualified nor tested in accordance with automotive testing or application requirements. Nexperia accepts no liability for inclusion and/or use of non-automotive qualified products in automotive equipment or applications.

In the event that customer uses the product for design-in and use in automotive applications to automotive specifications and standards, customer (a) shall use the product without Nexperia's warranty of the product for such automotive applications, use and specifications, and (b) whenever customer uses the product for automotive applications beyond Nexperia's specifications such use shall be solely at customer's own risk, and (c) customer fully indemnifies Nexperia for any liability, damages or failed product claims resulting from customer design and use of the product for automotive applications beyond Nexperia's standard warranty and Nexperia's product specifications.

**Translations** — A non-English (translated) version of a document is for reference only. The English version shall prevail in case of any discrepancy between the translated and English versions.

### Trademarks

Notice: All referenced brands, product names, service names and trademarks are the property of their respective owners.

## Contents

<b>1. General description</b> .....	<b>1</b>
<b>2. Features and benefits</b> .....	<b>1</b>
<b>3. Ordering information</b> .....	<b>1</b>
<b>4. Marking</b> .....	<b>2</b>
<b>5. Functional diagram</b> .....	<b>2</b>
<b>6. Pinning information</b> .....	<b>3</b>
6.1. Pinning.....	3
6.2. Pin description.....	3
<b>7. Functional description</b> .....	<b>4</b>
<b>8. Limiting values</b> .....	<b>4</b>
<b>9. Recommended operating conditions</b> .....	<b>4</b>
<b>10. Static characteristics</b> .....	<b>5</b>
10.1. Test circuits.....	5
10.2. ON resistance.....	6
10.3. ON resistance test circuit and graphs.....	7
<b>11. Dynamic characteristics</b> .....	<b>9</b>
11.1. Waveforms and test circuit.....	10
11.2. Additional dynamic characteristics.....	11
11.3. Test circuits.....	12
<b>12. Application information</b> .....	<b>14</b>
<b>13. Package outline</b> .....	<b>15</b>
<b>14. Abbreviations</b> .....	<b>18</b>
<b>15. Revision history</b> .....	<b>18</b>
<b>16. Legal information</b> .....	<b>19</b>

© Nexperia B.V. 2018. All rights reserved



For more information, please visit: <http://www.nexperia.com>

For sales office addresses, please send an email to: [salesaddresses@nexperia.com](mailto:salesaddresses@nexperia.com)

Date of release: 5 November 2018

## Looking for pricing, stock, or lifecycle information?

Click below to explore more details on WIN SOURCE:

-  [View 74LVCV2G66DC on WIN SOURCE](#)
-  [NXP / Nexperia Information](#)

## Optimize Your Supply Chain with WIN SOURCE Solutions

-  Global Sourcing Solution
-  Obsolete Management
-  Cost Control Management
-  Shortage Management
-  Alternative Solution
-  Excess Inventory Management