



THE DATASHEET OF STTH8S06D



Turbo 2 ultrafast high voltage rectifier

Datasheet - production data

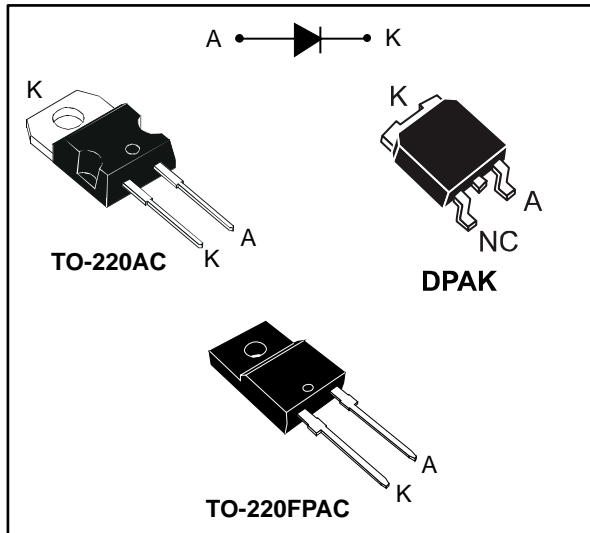

Description

This device is an ultrafast diode based on 600 V Pt doping planar technology.

It can be used in hard switching conditions for power factor corrections. Its extremely low reverse recovery current reduces the switching power losses of the MOSFET and thus increases the overall application efficiency.

This diode is also intended for applications in power supplies and power conversions systems, and all sorts of power switching.

Table 1: Device summary

Symbol	Value
$I_{F(AV)}$	8 A
V_{RRM}	600 V
$I_{RM}(typ.)$	4.4 A
$V_F (typ.)$	1.5 V
$T_j (max.)$	175 °C
$t_{rr} (typ.)$	12 ns

Features

- Ultrafast recovery
- Low reverse recovery current
- Low thermal resistance
- Higher frequency operation
- Reduces switching and conduction losses
- Insulated TO-220FPAC:
 - Insulating voltage = 2000 V_{RMS}
 - Package capacitance = 12 pF

1 Characteristics

Table 2: Absolute ratings (limiting values at 25 °C, unless otherwise specified)

Symbol	Parameter	Value	Unit	
V _{RRM}	Repetitive peak reverse voltage	600	V	
I _{F(AV)}	Average forward current $\delta = 0.5$ square wave	8	A	
I _{FSM}	Surge non repetitive forward current	t _p = 10 ms	60	A
T _{stg}	Storage temperature range	-65 to +175	°C	
T _j	Maximum operating junction temperature	175		

Table 3: Thermal parameters

Symbol	Parameter	Max. value	Unit	
R _{th(j-c)}	Junction to case	TO-220AC, DPAK	3.0	°C/W
		TO-220FPAC	5.5	

Table 4: Static electrical characteristics (per diode)

Symbol	Parameter	Test conditions	Min.	Typ.	Max.	Unit	
I _R	Reverse leakage current	T _j = 25 °C	V _R = 600 V	-		20	µA
		T _j = 125 °C		-	25	200	
V _F	Forward voltage drop	T _j = 25 °C	I _F = 8 A	-		3.4	V
		T _j = 150 °C		-	1.5	1.9	

To evaluate the maximum conduction losses, use the following equation:

$$P = 1.20 \times I_{F(AV)} + 0.087 \times I_{F(RMS)}^2$$

Table 5: Dynamic electrical characteristics

Symbol	Parameter	Test conditions	Min.	Typ.	Max.	Unit	
t _{rr}	Reverse recovery time	T _j = 25 °C	I _F = 1 A, dI _F /dt = - 200 A/µs, V _R = 30 V	-	12	18	ns
I _{RM}	Reverse recovery current			-	1.6	2.2	A
S _{factor}	Softness factor			-	1		-
Q _{rr}	Reverse recovery charges			-	17		nC
I _{RM}	Reverse recovery current	T _j = 125 °C	I _F = 8 A, dI _F /dt = - 200 A/µs, V _R = 200 V	-	4.4	6.0	A
S _{factor}	Softness factor			-	0.3		-
Q _{rr}	Reverse recovery charges			-	90		nC

1.2 Characteristics (curves)

Figure 1: Forward voltage drop versus forward current

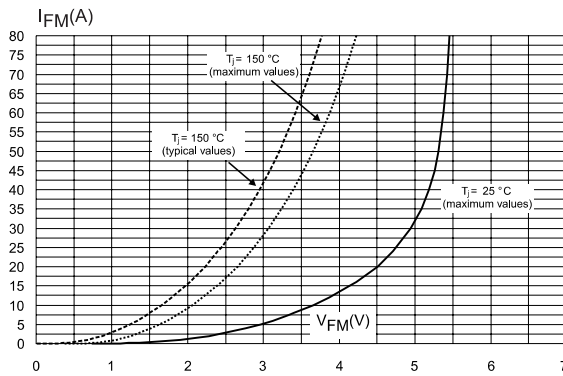

Figure 2: Relative variation of thermal impedance junction to case versus pulse duration (TO-220AC)

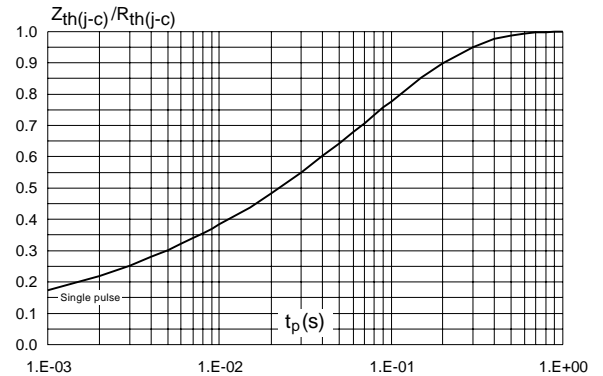

Figure 3: Relative variation of thermal impedance junction to case versus pulse duration (TO-220FPAC)

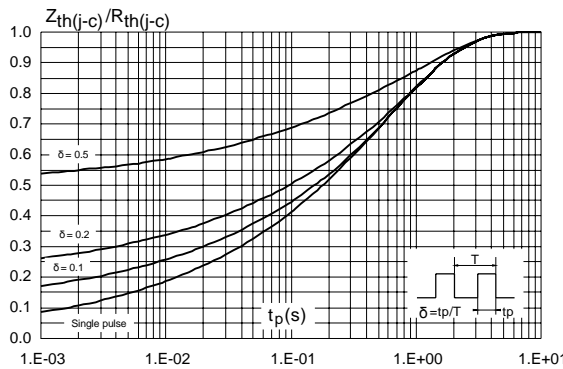

Figure 4: Relative variation of thermal impedance junction to case versus pulse duration (DPAK)

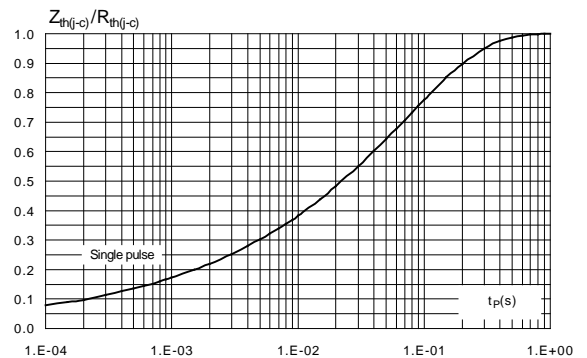

Figure 5: Peak reverse recovery current versus di_F/dt (typical values)

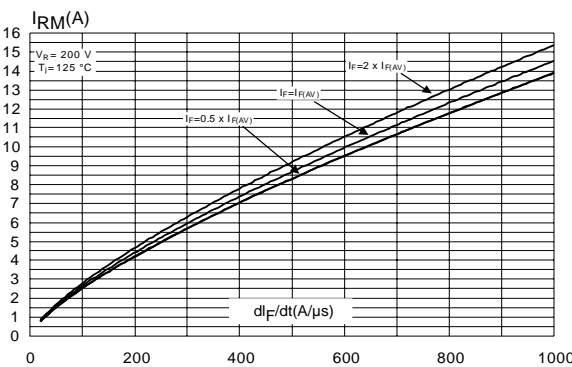

Figure 6: Reverse recovery time versus di_F/dt (typical values)

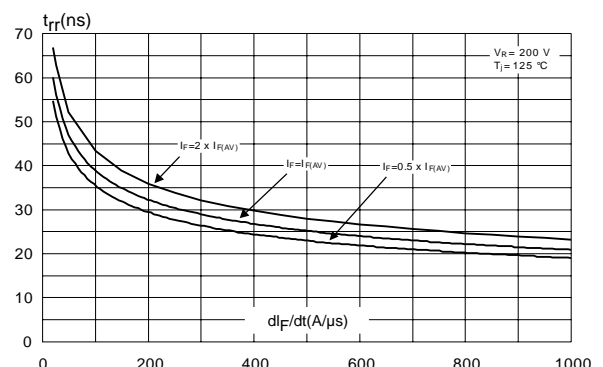

Figure 7: Reverse recovery charges versus di_F/dt (typical values)

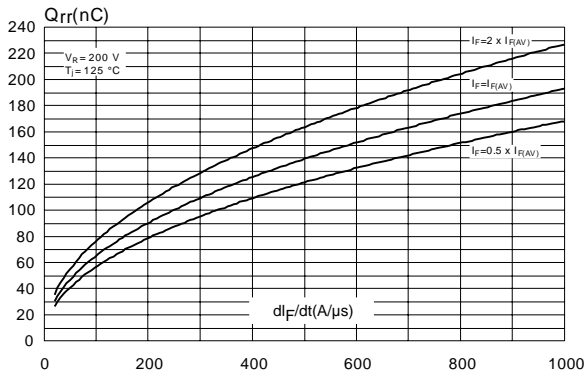

Figure 8: Junction capacitance versus reverse voltage applied (typical values)

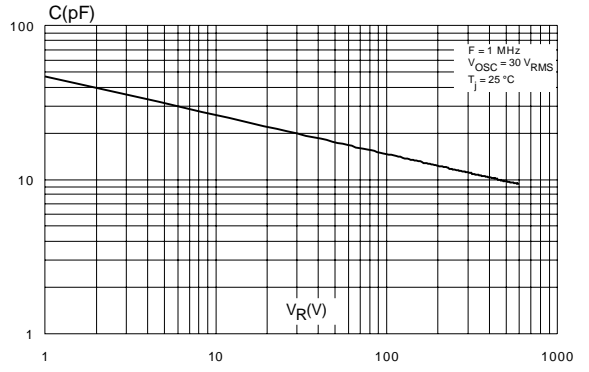
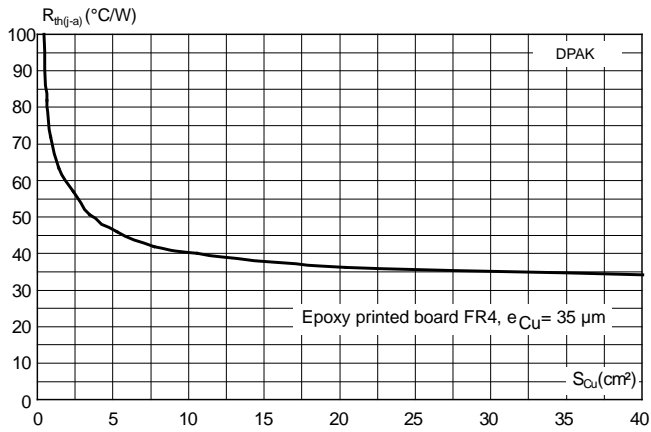

Figure 9: Thermal resistance junction to ambient versus copper surface under tab (DPAK, typical values)



2 Package information

In order to meet environmental requirements, ST offers these devices in different grades of ECOPACK® packages, depending on their level of environmental compliance. ECOPACK® specifications, grade definitions and product status are available at: www.st.com. ECOPACK® is an ST trademark.

- Cooling method: by conduction (C)
- Epoxy meets UL 94,V0
- Recommended torque value: 0.55 N·m
- Maximum torque value: 0.7 N·m

2.1 TO-220AC package information

Figure 10: TO-220AC package outline

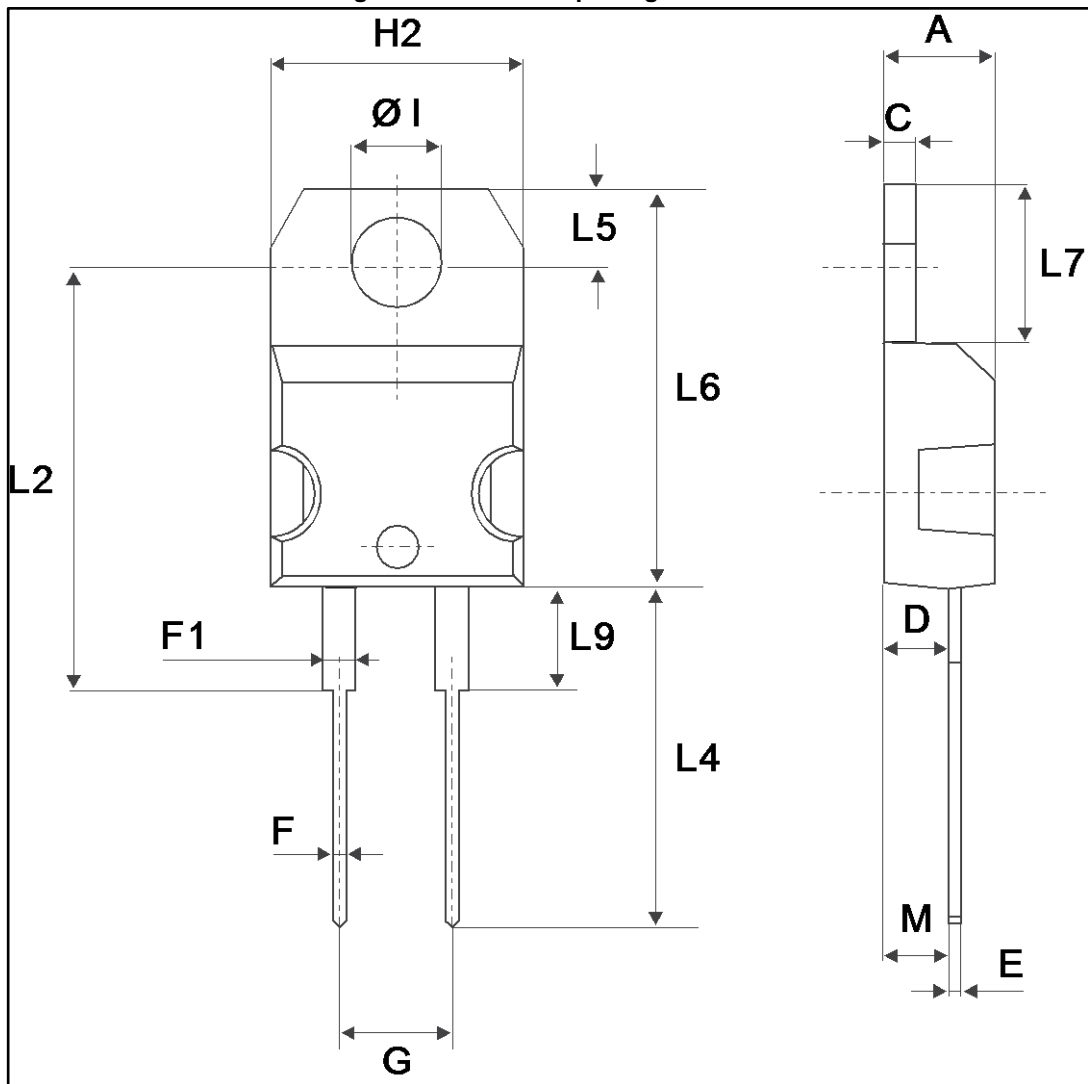

Table 6: TO-220AC package mechanical data

Ref.	Dimensions			
	Millimeters		Inches	
	Min.	Max.	Min.	Max.
A	4.40	4.60	0.173	0.181
C	1.23	1.32	0.048	0.051
D	2.40	2.72	0.094	0.107
E	0.49	0.70	0.019	0.027
F	0.61	0.88	0.024	0.034
F1	1.14	1.70	0.044	0.066
G	4.95	5.15	0.194	0.202
H2	10.00	10.40	0.393	0.409
L2	16.40 typ.		0.645 typ.	
L4	13.00	14.00	0.511	0.551
L5	2.65	2.95	0.104	0.116
L6	15.25	15.75	0.600	0.620
L7	6.20	6.60	0.244	0.259
L9	3.50	3.93	0.137	0.154
M	2.6 typ.		0.102 typ.	
Diam	3.75	3.85	0.147	0.151

2.2 TO-220FPAC package information

Figure 11: TO-220FPAC package outline

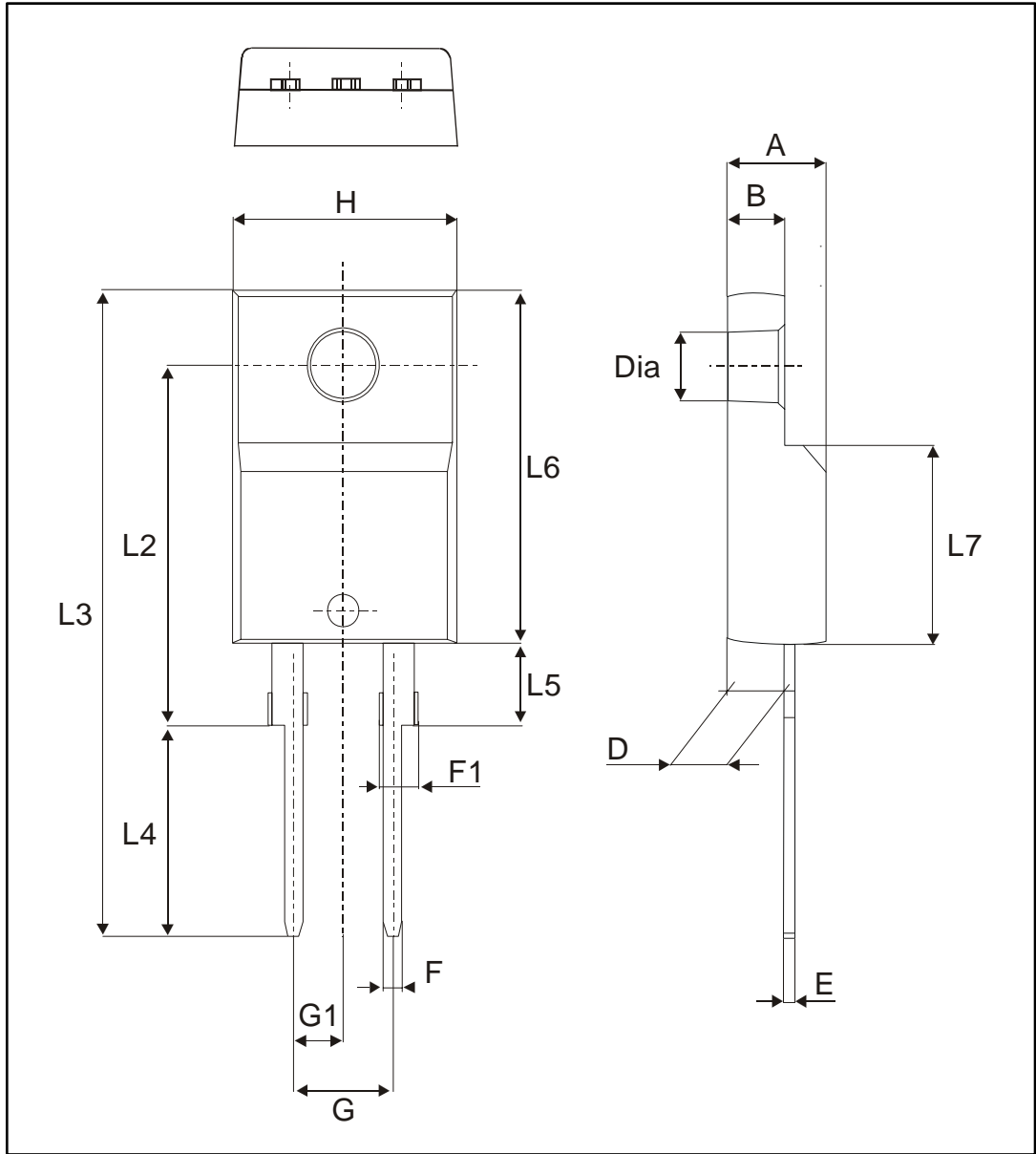
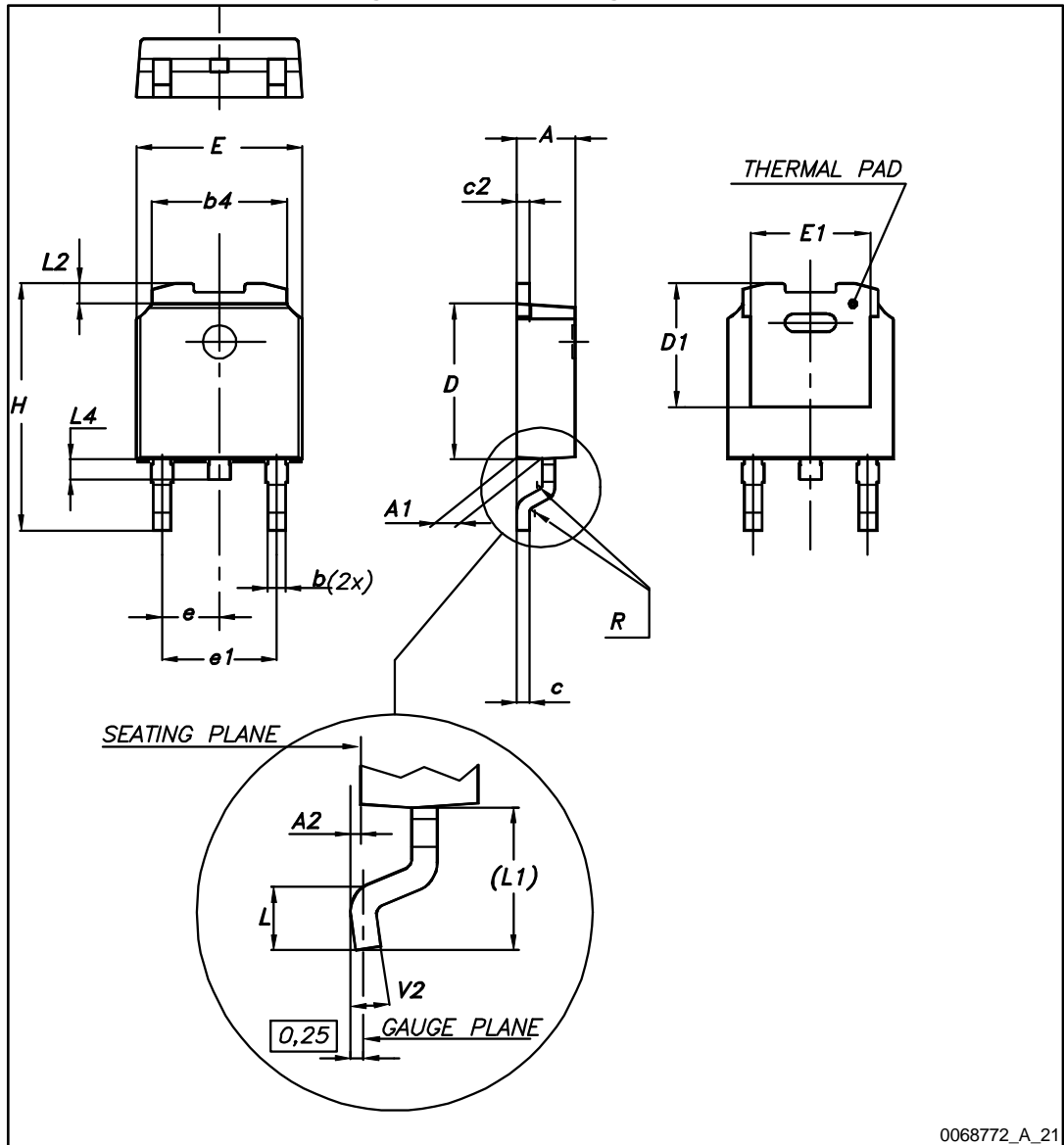

Table 7: TO-220FPAC package mechanical data

Ref.	Dimensions			
	Millimeters		Inches	
	Min.	Max.	Min.	Max.
A	4.40	4.60	0.173	0.181
B	2.50	2.70	0.098	0.106
D	2.50	2.75	0.098	0.108
E	0.45	0.70	0.018	0.027
F	0.75	1.00	0.030	0.039
F1	1.15	1.70	0.045	0.067
G	4.95	5.20	0.195	0.205
G1	2.40	2.70	0.094	0.106
H	10.00	10.40	0.393	0.409
L2	16.00 typ.		0.630 typ.	
L3	28.60	30.60	0.126	1.205
L4	9.80	10.60	0.386	0.417
L5	2.90	3.60	0.114	0.142
L6	15.90	16.40	0.626	0.646
L7	9.00	9.30	0.354	0.366
Dia.	3.00	3.20	0.118	0.126

2.3 DPAK package information

Figure 12: DPAK package outline



0068772_A_21

Table 8: DPAK mechanical data

Dim.	Dimensions					
	Millimeters			Inches		
	Min.	Typ.	Max.	Min.	Typ.	Max.
A	2.20		2.40	0.087		0.094
A1	0.90		1.10	0.035		0.043
A2	0.03		0.23	0.001		0.009
b	0.64		0.90	0.025		0.035
b4	5.20		5.40	0.205		0.213
c	0.45		0.60	0.018		0.024
c2	0.48		0.60	0.019		0.024
D	6.00		6.20	0.236		0.244
D1	4.95	5.10	5.25	0.201	0.195	0.207
E	6.40		6.60	0.252		0.260
E1	4.60	4.70	4.80	0.181	0.185	0.189
e	2.16	2.28	2.40	0.085	0.090	0.094
e1	4.40		4.60	0.173		0.181
H	9.35		10.10	0.368		0.398
L	1.00		1.50	0.039		0.059
(L1)	2.60	2.80	3.00	0.102	0.110	0.118
L2	0.65	0.80	0.95	0.026	0.031	0.037
L4	0.60		1.00	0.024		0.039
R		0.20			0.008	
V2	0°		8°	0°		8°

Figure 13: DPAK recommended footprint (dimensions are in mm)

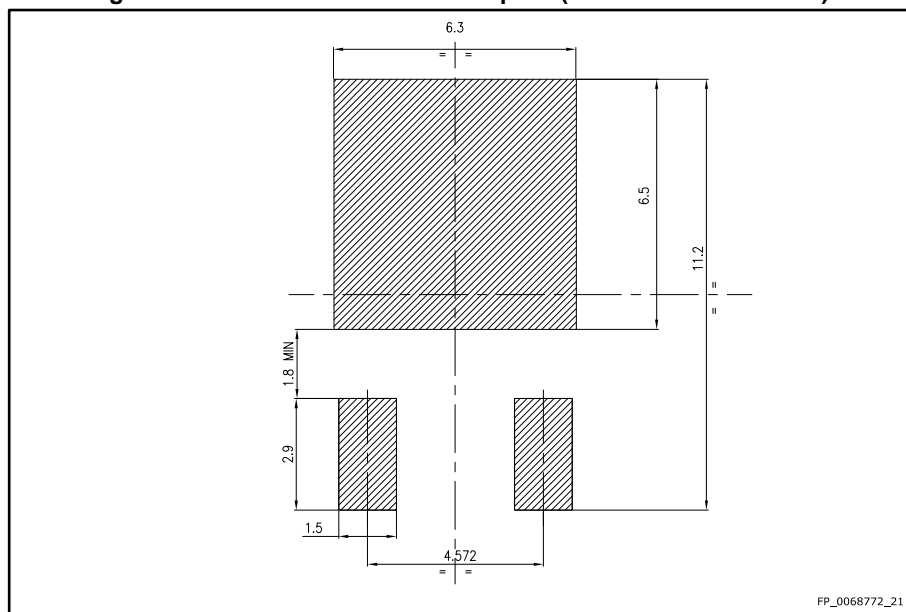

3 Ordering information

Table 9: Ordering information

Order code	Marking	Package	Weight	Base qty.	Delivery mode
STTH8S06D	STTH8S06D	TO-220AC	1.9 g	50	Tube
STTH8S06FP	STTH8S06FP	TO-220FPAC	1.64 g	50	Tube
STTH8S06B-TR	STTH8 S06B	DPAK	0.35 g	2500	Tape and reel

4 Revision history

Table 10: Document revision history

Date	Revision	Changes
18-Dec-2007	1	first issue
10-Feb-2017	2	Added DPAK package. Updated Section "Features" .

IMPORTANT NOTICE – PLEASE READ CAREFULLY

STMicroelectronics NV and its subsidiaries ("ST") reserve the right to make changes, corrections, enhancements, modifications, and improvements to ST products and/or to this document at any time without notice. Purchasers should obtain the latest relevant information on ST products before placing orders. ST products are sold pursuant to ST's terms and conditions of sale in place at the time of order acknowledgement.

Purchasers are solely responsible for the choice, selection, and use of ST products and ST assumes no liability for application assistance or the design of Purchasers' products.

No license, express or implied, to any intellectual property right is granted by ST herein.

Resale of ST products with provisions different from the information set forth herein shall void any warranty granted by ST for such product.

ST and the ST logo are trademarks of ST. All other product or service names are the property of their respective owners.

Information in this document supersedes and replaces information previously supplied in any prior versions of this document.

© 2017 STMicroelectronics – All rights reserved

Looking for pricing, stock, or lifecycle information?

Click below to explore more details on WIN SOURCE:

- ⊖ [View STTH8S06D on WIN SOURCE](#)
- ⊖ [STMicroelectronics Information](#)

Optimize Your Supply Chain with WIN SOURCE Solutions

- ✓ Global Sourcing Solution
- ✓ Obsolete Management
- ✓ Cost Control Management
- ✓ Shortage Management
- ✓ Alternative Solution
- ✓ Excess Inventory Management