



# THE DATASHEET OF STPS745D



**Power Schottky rectifier**

Datasheet - production data

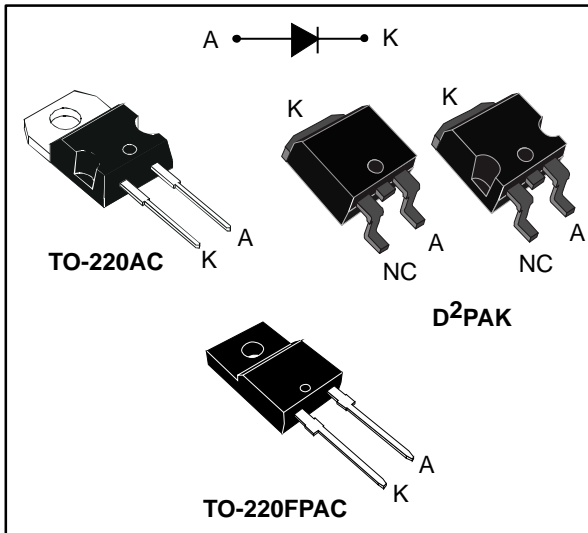
**Features**

- Very small conduction losses
- Negligible switching losses
- Extremely fast switching
- Insulated package: TO-220FPAC
  - Insulating voltage = 2000  $V_{RMS}$  sine
- Avalanche capability specified
- ECOPACK®2 compliant component for D²PAK on demand

**Description**

Single Schottky rectifier suited for Switch Mode Power Supply and high frequency DC to DC converters.

Packaged either in TO-220AC, TO-220FPAC or D²PAK, this device is intended for use in low voltage, high frequency inverters, free wheeling and polarity protection applications.

**Table 1: Device summary**

Symbol	Value
$I_{F(AV)}$	7.5 A
$V_{RRM}$	45 V
$T_j$ (max)	175 °C
$V_F$ (typ)	0.5 V

# 1 Characteristics

**Table 2: Absolute ratings (limiting values, at 25 °C, unless otherwise specified)**

Symbol	Parameter			Value	Unit
V <sub>RRM</sub>	Repetitive peak reverse voltage			45	V
I <sub>F(RMS)</sub>	Forward rms current			20	A
I <sub>F(AV)</sub>	Average forward current δ = 0.5, square wave	TO-220AC / D <sup>2</sup> PAK	T <sub>C</sub> = 160 °C	7.5	A
		TO-220FPAC	T <sub>C</sub> = 145 °C		
I <sub>FSM</sub>	Surge non repetitive forward current	tp = 10 ms sinusoidal		150	A
P <sub>ARM</sub>	Repetitive peak avalanche power	tp = 10 μs, T <sub>j</sub> = 125 °C		190	W
T <sub>stg</sub>	Storage temperature range			-65 to + 175	°C
T <sub>j</sub>	Maximum operating junction temperature <sup>(1)</sup>			+ 175	°C

**Notes:**

<sup>(1)</sup>(dP<sub>tot</sub>/dT<sub>j</sub>) < (1/R<sub>th(j-a)</sub>) condition to avoid thermal runaway for a diode on its own heatsink.

**Table 3: Thermal parameter**

Symbol	Parameter		Value	Unit
R <sub>th(j-c)</sub>	Junction to case	TO-220AC / D <sup>2</sup> PAK	3.0	°C/W
		TO-220FPAC	5.5	

**Table 4: Static electrical characteristics**

Symbol	Parameter	Test conditions		Min.	Typ.	Max.	Unit
I <sub>R</sub> <sup>(1)</sup>	Reverse leakage current	T <sub>j</sub> = 25 °C	V <sub>R</sub> = V <sub>RRM</sub>	-		100	μA
		T <sub>j</sub> = 125 °C		-	5	15	mA
V <sub>F</sub> <sup>(1)</sup>	Forward voltage drop	T <sub>j</sub> = 125 °C	I <sub>F</sub> = 7.5 A	-	0.5	0.57	V
		T <sub>j</sub> = 25 °C	I <sub>F</sub> = 15 A	-		0.84	
		T <sub>j</sub> = 125 °C	I <sub>F</sub> = 15 A	-	0.65	0.72	

**Notes:**

<sup>(1)</sup>Pulse test: tp = 380 μs, δ < 2%

To evaluate the conduction losses use the following equation:

$$P = 0.42 \times I_{F(AV)} + 0.020 I_{F(RMS)}^2$$

# 1.1 Characteristics (curves)

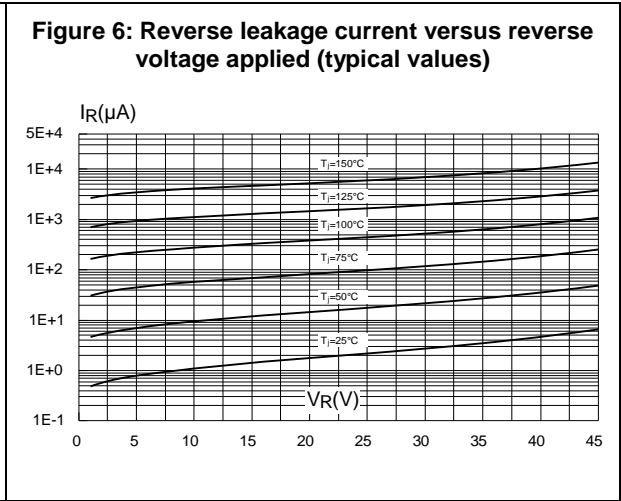
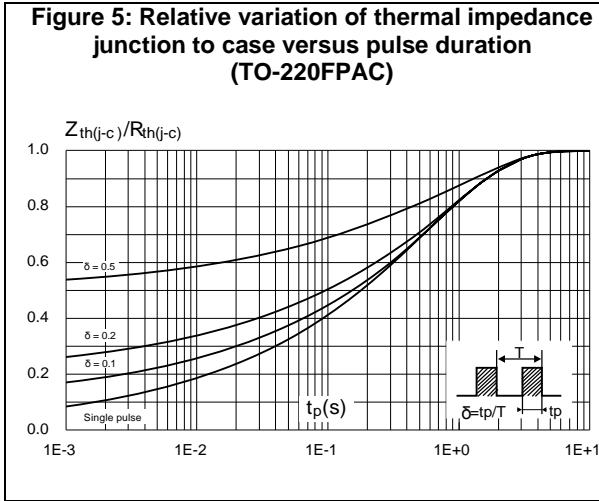
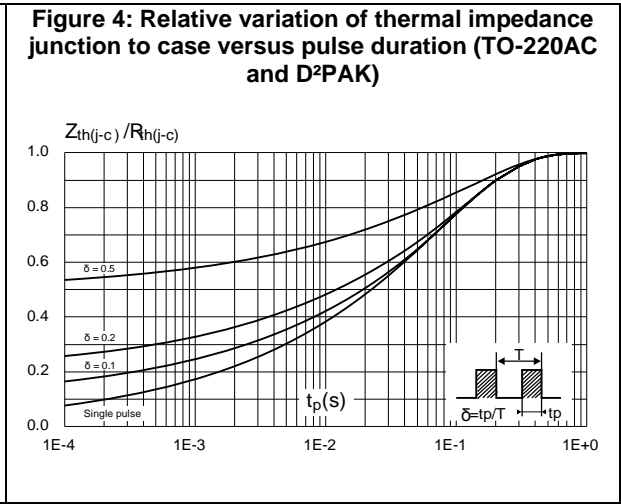
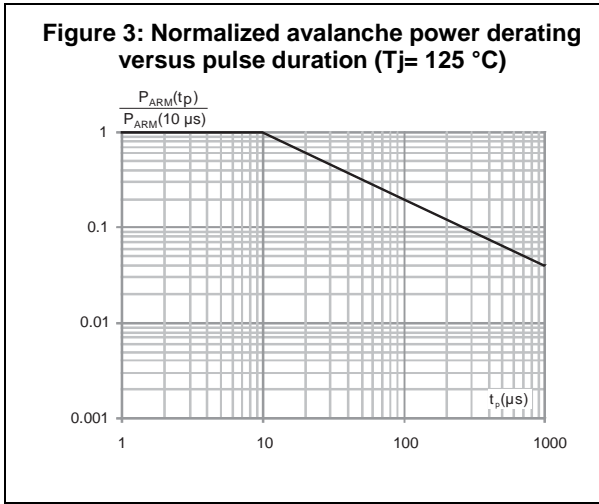
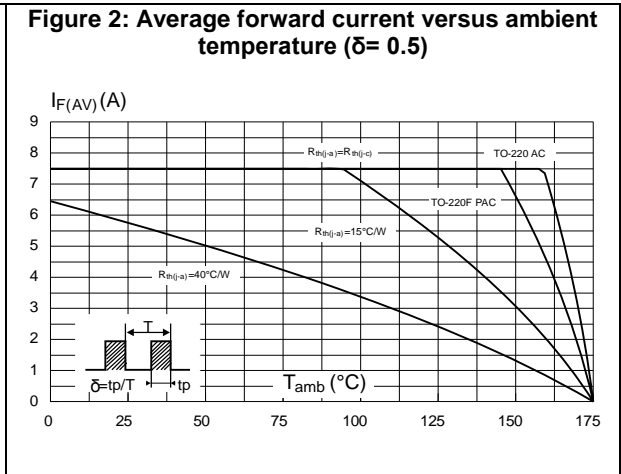
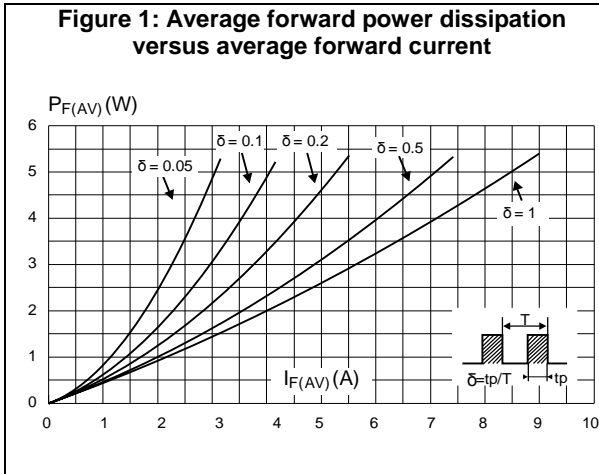

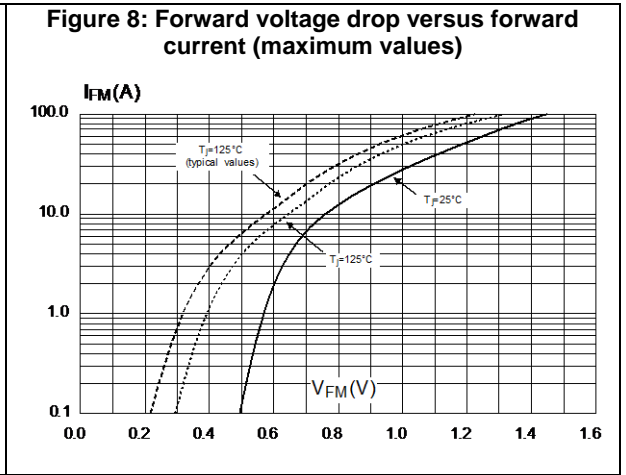
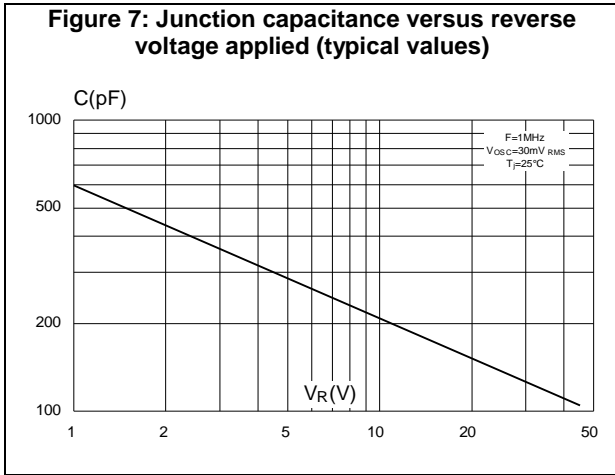

**Figure 9: Thermal resistance junction to ambient versus copper surface under tab (epoxy printed board FR4, eCu: 35  $\mu$ m)**

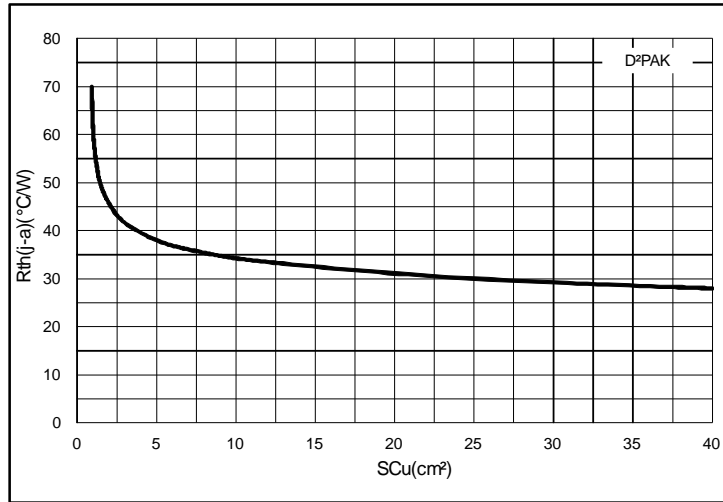

## 2 Package information

In order to meet environmental requirements, ST offers these devices in different grades of ECOPACK® packages, depending on their level of environmental compliance. ECOPACK® specifications, grade definitions and product status are available at: [www.st.com](http://www.st.com). ECOPACK® is an ST trademark.

- Cooling method: by conduction (C)
- Epoxy meets UL 94,V0
- Recommended torque value: 0.55 Nm (for TO-220AC and TO-220FPAC)
- Maximum torque value: 0.70 Nm (for TO-220AC and TO-220FPAC)

### 2.1 D<sup>2</sup>PAK package information

Figure 10: D<sup>2</sup>PAK package outline

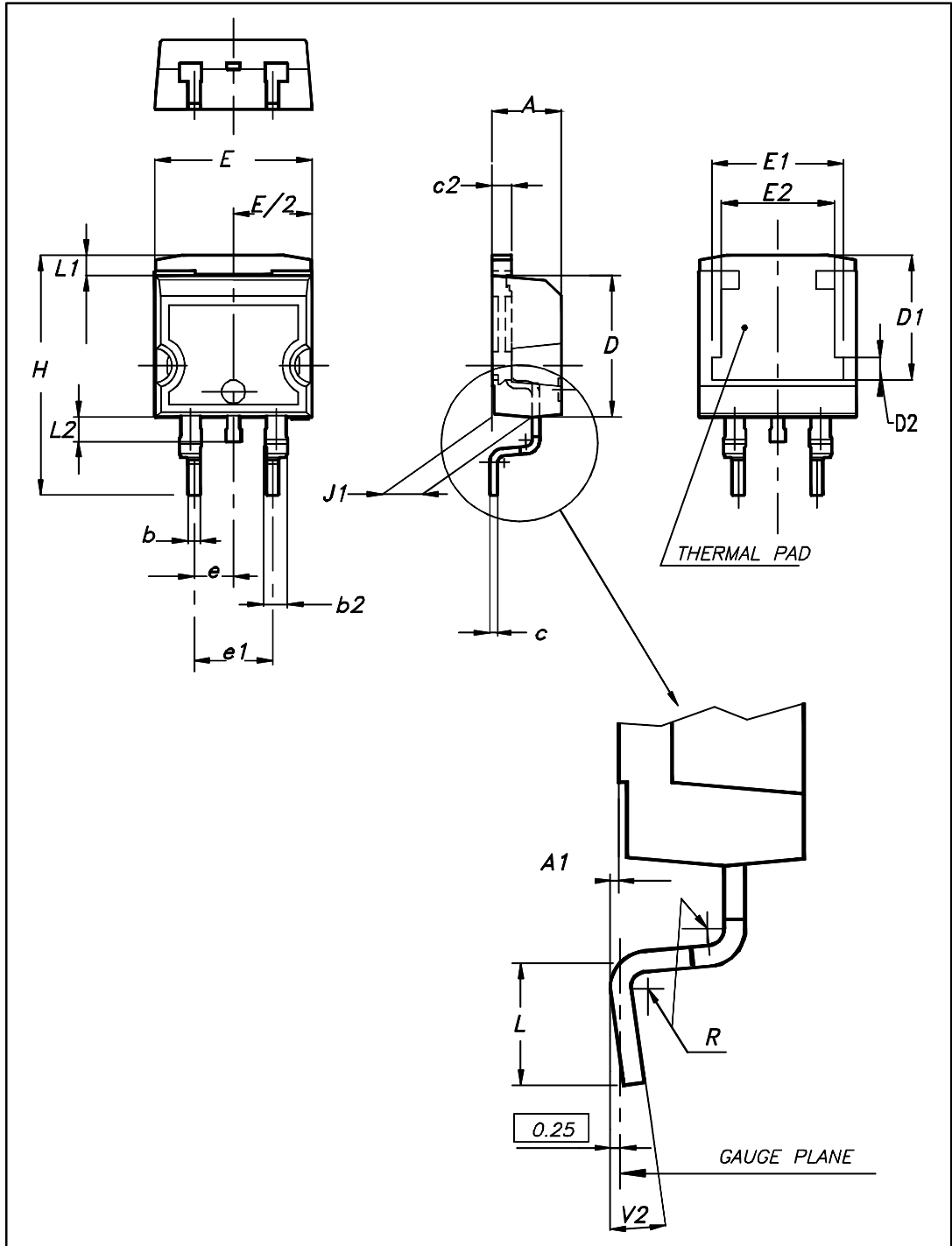

This package drawing may slightly differ from the physical package. However, all the specified dimensions are guaranteed.

Table 5: D<sup>2</sup>PAK package mechanical data

Ref.	Dimensions			
	Millimeters		Inches	
	Min.	Max.	Min.	Max.
A	4.36	4.60	0.172	0.181
A1	0.00	0.25	0.000	0.010
b	0.70	0.93	0.028	0.037
b2	1.14	1.70	0.045	0.067
c	0.38	0.69	0.015	0.027
c2	1.19	1.36	0.047	0.053
D	8.60	9.35	0.339	0.368
D1	6.90	8.00	0.272	0.311
D2	1.10	1.50	0.043	0.060
E	10.00	10.55	0.394	0.415
E1	8.10	8.90	0.319	0.346
E2	6.85	7.25	0.266	0.282
e	2.54 typ.		0.100	
e1	4.88	5.28	0.190	0.205
H	15.00	15.85	0.591	0.624
J1	2.49	2.90	0.097	0.112
L	1.90	2.79	0.075	0.110
L1	1.27	1.65	0.049	0.065
L2	1.30	1.78	0.050	0.070
R	0.4 typ.		0.015	
V2	0°	8°	0°	8°

Figure 11: D<sup>2</sup>PAK recommended footprint (dimensions in mm)

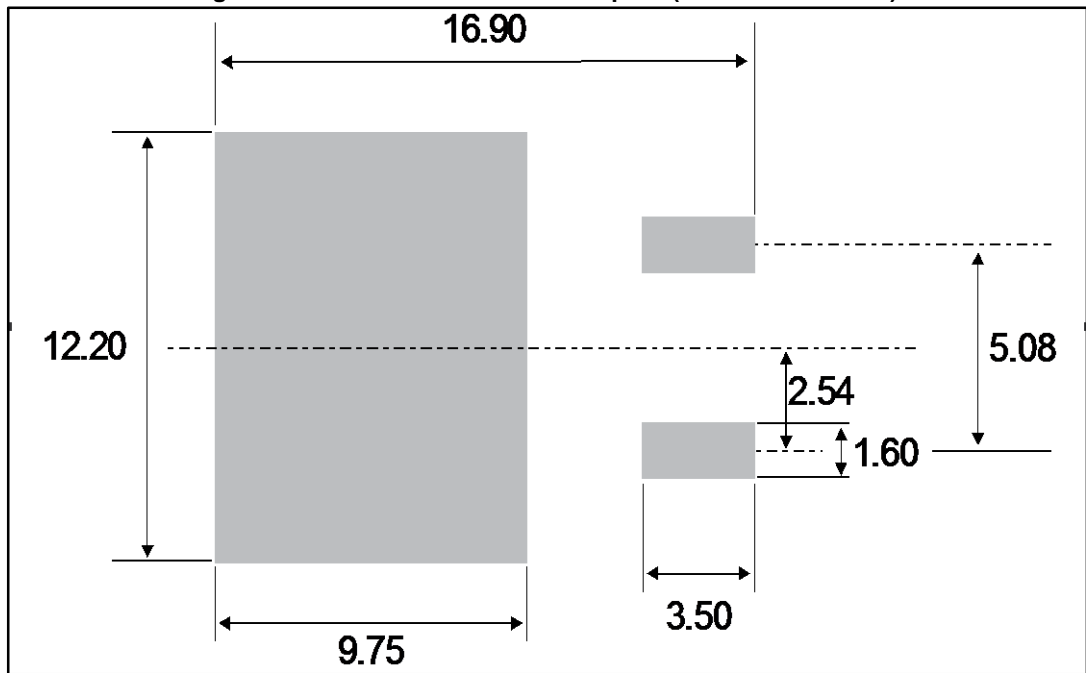

## 2.2 TO-220AC package information

Figure 12: TO-220AC package outline

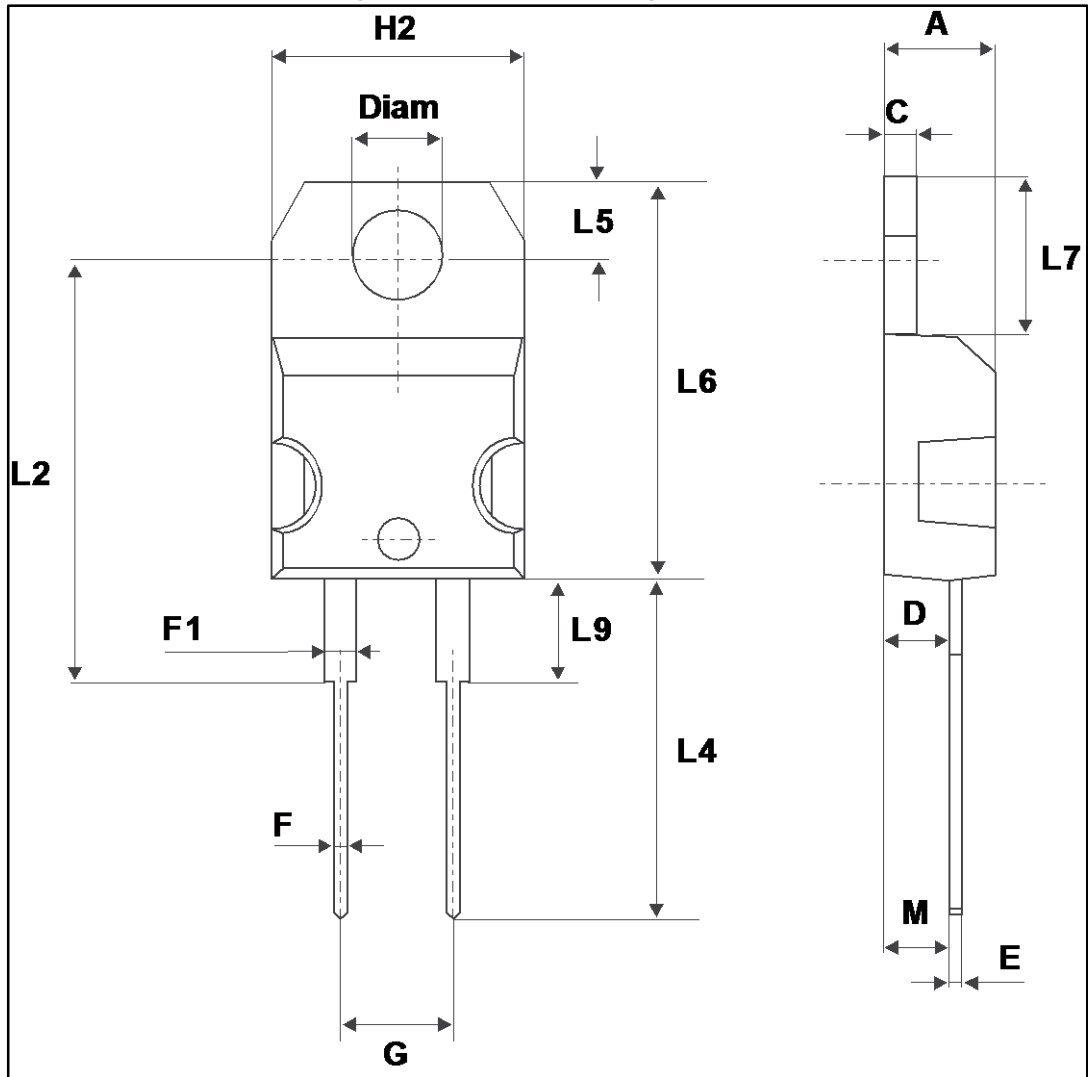

Table 6: TO-220AC package mechanical data

Ref.	Dimensions			
	Millimeters		Inches	
	Min.	Max.	Min.	Max.
A	4.40	4.60	0.173	0.181
C	1.23	1.32	0.048	0.051
D	2.40	2.72	0.094	0.107
E	0.49	0.70	0.019	0.027
F	0.61	0.88	0.024	0.034
F1	1.14	1.70	0.044	0.066
G	4.95	5.15	0.194	0.202
H2	10.00	10.40	0.393	0.409
L2	16.40 typ.		0.645 typ.	
L4	13.00	14.00	0.511	0.551
L5	2.65	2.95	0.104	0.116
L6	15.25	15.75	0.600	0.620
L7	6.20	6.60	0.244	0.259
L9	3.50	3.93	0.137	0.154
M	2.6 typ.		0.102 typ.	
Diam	3.75	3.85	0.147	0.151



Table 7: TO-220AC package mechanical data

Ref.	Dimensions			
	Millimeters		Inches	
	Min.	Max.	Min.	Max.
A	4.4	4.6	0.173	0.181
B	2.5	2.7	0.098	0.106
D	2.5	2.75	0.098	0.108
E	0.45	0.70	0.018	0.027
F	0.75	1	0.030	0.039
F1	1.15	1.70	0.045	0.067
G	4.95	5.20	0.195	0.205
G1	2.4	2.7	0.094	0.106
H	10	10.4	0.393	0.409
L2	16 typ.		0.63 typ.	
L3	28.6	30.6	0.126	1.205
L4	9.8	10.6	0.386	0.417
L5	2.9	3.6	0.114	0.142
L6	15.9	16.4	0.626	0.646
L7	9.00	9.30	0.354	0.366
Dia.	3.00	3.20	0.118	0.126

### 3 Ordering information

Table 8: Ordering information

Order code	Marking	Package	Weight	Base qty.	Delivery mode
STPS745D	STPS745D	TO-220AC	1.86g	50	Tube
STPS745G-TR	STPS745G	D <sup>2</sup> PAK	1.38g	1000	Tape and reel
STPS745FP	STPS745FP	TO-220FPAC	1.9g	50	Tube

### 4 Revision history

Table 9: Document revision history

Date	Revision	Changes
Jul-2003	6	Last release
22-Mar-2007	7	Removed ISOWATT package.
29-May-2015	8	Updated features, packages silhouette and <a href="#">Table 1: "Device summary"</a> in cover page. Updated <a href="#">Table 2: "Absolute ratings (limiting values, at 25 °C, unless otherwise specified)"</a> and <a href="#">Section 1.1: "Characteristics (curves)"</a> . Minor text changes.

**IMPORTANT NOTICE – PLEASE READ CAREFULLY**

STMicroelectronics NV and its subsidiaries ("ST") reserve the right to make changes, corrections, enhancements, modifications, and improvements to ST products and/or to this document at any time without notice. Purchasers should obtain the latest relevant information on ST products before placing orders. ST products are sold pursuant to ST's terms and conditions of sale in place at the time of order acknowledgement.

Purchasers are solely responsible for the choice, selection, and use of ST products and ST assumes no liability for application assistance or the design of Purchasers' products.

No license, express or implied, to any intellectual property right is granted by ST herein.

Resale of ST products with provisions different from the information set forth herein shall void any warranty granted by ST for such product.

ST and the ST logo are trademarks of ST. All other product or service names are the property of their respective owners.

Information in this document supersedes and replaces information previously supplied in any prior versions of this document.

© 2015 STMicroelectronics – All rights reserved

## Looking for pricing, stock, or lifecycle information?

Click below to explore more details on WIN SOURCE:

- ⊖ [View STPS745D on WIN SOURCE](#)
- ⊖ [STMicroelectronics Information](#)

## Optimize Your Supply Chain with WIN SOURCE Solutions

- ✓ Global Sourcing Solution
- ✓ Obsolete Management
- ✓ Cost Control Management
- ✓ Shortage Management
- ✓ Alternative Solution
- ✓ Excess Inventory Management