

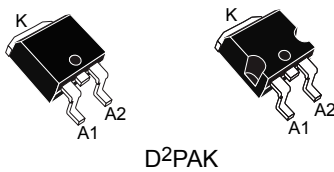

# THE DATASHEET OF STPS20150CFP

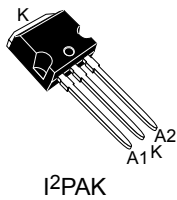

## High voltage power Schottky rectifier

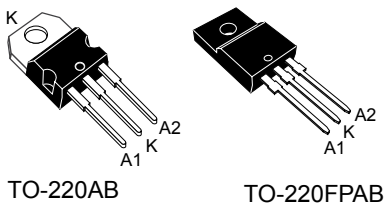
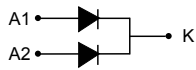

## Features

- High junction temperature capability
- Good trade off between leakage current and forward voltage drop
- Low leakage current
- Avalanche capability specified
- Insulated package: TO-220FPAB
  - Insulating voltage = 2000 V<sub>RMS</sub> sine
- ECOPACK<sup>®</sup>2 compliant component for D<sup>2</sup>PAK on demand

## Description

Dual center tap Schottky rectifier designed for high frequency switch mode power supplies.

## Product status link

[STPS20150C](#)

## Product summary

$I_{F(AV)}$	2 x 10 A
$V_{RRM}$	150 V
$T_j$ (max)	175 °C
$V_F$ (typ)	0.69 V

# 1 Characteristics

**Table 1. Absolute ratings (limiting values, per diode, at 25 °C, unless otherwise specified)**

Symbol	Parameter			Value	Unit	
V <sub>RRM</sub>	Repetitive peak reverse voltage			150	V	
I <sub>F(RMS)</sub>	Forward rms current			30	A	
I <sub>F(AV)</sub>	Average forward current $\delta = 0.5$ , square wave	TO-220AB, D <sup>2</sup> PAK, I <sup>2</sup> PAK	T <sub>C</sub> = 155 °C Per diode	10	A	
		TO-220FPAB	T <sub>C</sub> = 135 °C Per diode			
		All types		Per device		20
I <sub>FSM</sub>	Surge non repetitive forward current			tp = 10 ms sinusoidal	180	A
P <sub>ARM</sub>	Repetitive peak avalanche power			tp = 10 $\mu$ s, T <sub>J</sub> = 125 °C	480	W
T <sub>stg</sub>	Storage temperature range			-65 to + 175	°C	
T <sub>j</sub>	Maximum operating junction temperature <sup>(1)</sup>			+ 175	°C	

1.  $(dP_{tot}/dT_j) < (1/R_{th(j-a)})$  condition to avoid thermal runaway for a diode on its own heatsink.

**Table 2. Thermal parameter**

Symbol	Parameter			Value	Unit
R <sub>th(j-c)</sub>	Junction to case	TO-220AB, D <sup>2</sup> PAK, I <sup>2</sup> PAK	Per diode	2.2	°C/W
		TO-220FPAB		4.5	
		TO-220AB, D <sup>2</sup> PAK, I <sup>2</sup> PAK	Total	1.3	
		TO-220FPAB		3.5	
R <sub>th(c)</sub>	Coupling	TO-220AB, D <sup>2</sup> PAK, I <sup>2</sup> PAK	-	0.3	°C/W
		TO-220FPAB		2.5	

When the diodes 1 and 2 are used simultaneously :

$$\Delta T_j(\text{diode } 1) = P(\text{diode } 1) \times R_{th(j-c)}(\text{Per diode}) + P(\text{diode } 2) \times R_{th(c)}$$

**Table 3. Static electrical characteristics (per diode)**

Symbol	Parameter	Test conditions		Min.	Typ.	Max.	Unit
I <sub>R</sub> <sup>(1)</sup>	Reverse leakage current	T <sub>J</sub> = 25 °C	V <sub>R</sub> = V <sub>RRM</sub>	-		5.0	$\mu$ A
		T <sub>J</sub> = 125 °C		-		5.0	mA
V <sub>F</sub> <sup>(2)</sup>	Forward voltage drop	T <sub>J</sub> = 25 °C	I <sub>F</sub> = 10 A	-		0.92	V
				-	0.69	0.75	
			I <sub>F</sub> = 20A	-		1.0	
				-	0.79	0.86	

1. Pulse test: t<sub>p</sub> = 5 ms,  $\delta < 2\%$

2. Pulse test: t<sub>p</sub> = 380  $\mu$ s,  $\delta < 2\%$

To evaluate the conduction losses use the following equation:  $P = 0.64 \times I_{F(AV)} + 0.011 I_{F(RMS)}^2$

### 1.1 Characteristics (curves)

**Figure 1. Average forward power dissipation versus average forward current (per diode)**

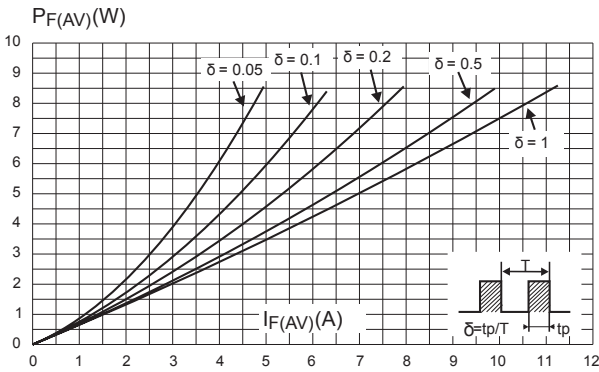

**Figure 2. Average forward current versus ambient temperature ( $\delta = 0.5$ , per diode)**

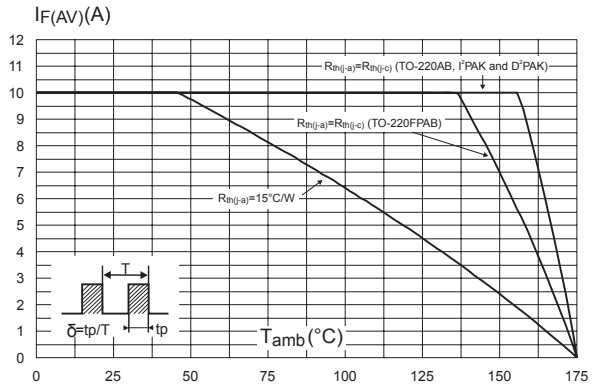

**Figure 3. Normalized avalanche power derating versus pulse ( $T_j = 125^{\circ}C$ )**

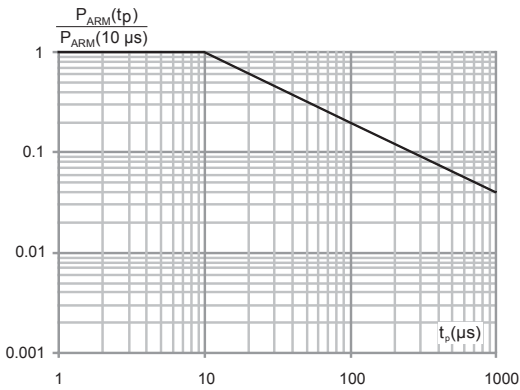

**Figure 4. Relative variation of thermal impedance junction to case versus pulse duration (per diode)**

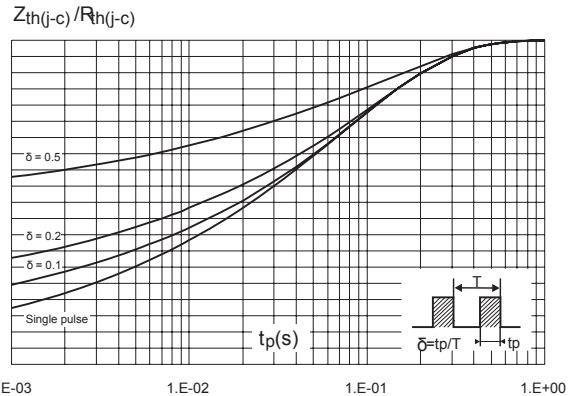

**Figure 5. Relative variation of thermal impedance junction to case versus pulse duration (per diode)**

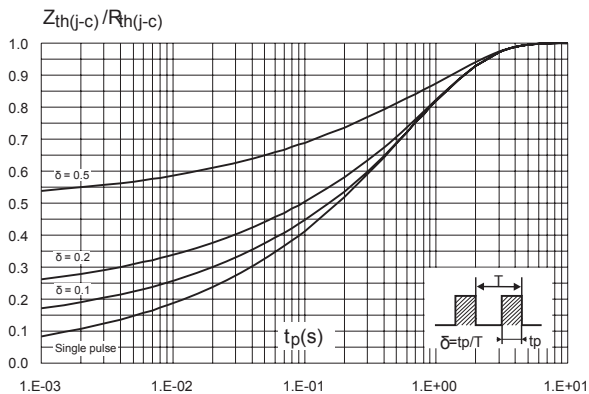

**Figure 6. Reverse leakage current versus reverse voltage applied (typical values, per diode)**

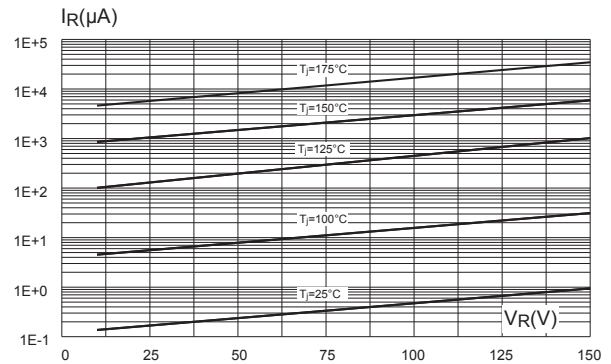

**Figure 7. Junction capacitance versus reverse voltage applied (typical values, per diode)**

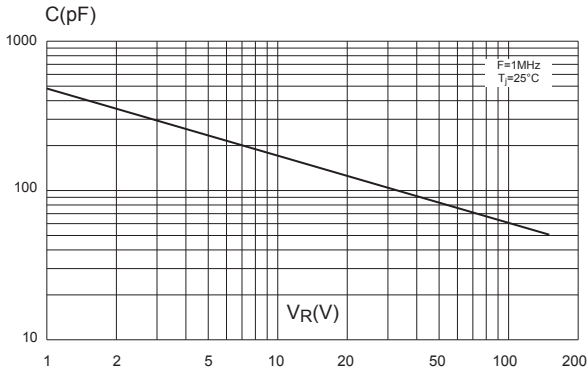

**Figure 8. Forward voltage drop versus forward current (maximum values, per diode)**

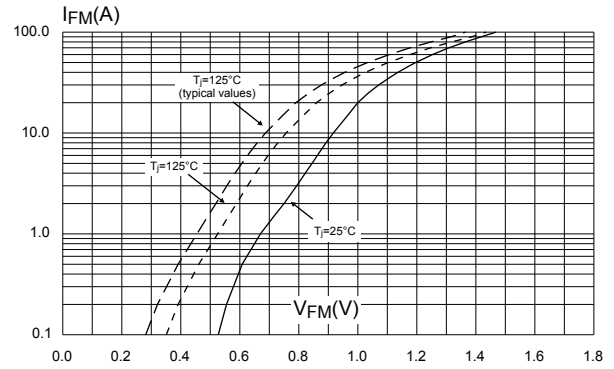

**Figure 9. Thermal resistance junction to ambient versus copper surface under tab (epoxy printed board FR4,  $\epsilon_{Cu} = 35 \mu\text{m}$ ) (D<sup>2</sup>PAK)**

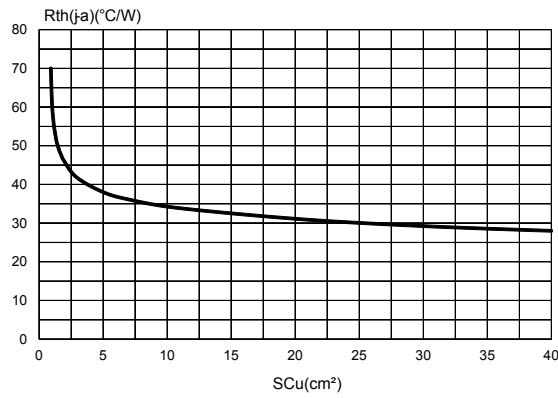

## 2 Package information

---

In order to meet environmental requirements, ST offers these devices in different grades of ECOPACK® packages, depending on their level of environmental compliance. ECOPACK® specifications, grade definitions and product status are available at: [www.st.com](http://www.st.com). ECOPACK® is an ST trademark.

## 2.1 D<sup>2</sup>PAK package information

- Cooling method: by conduction (C)
- Epoxy meets UL 94,V0

Figure 10. D<sup>2</sup>PAK package outline

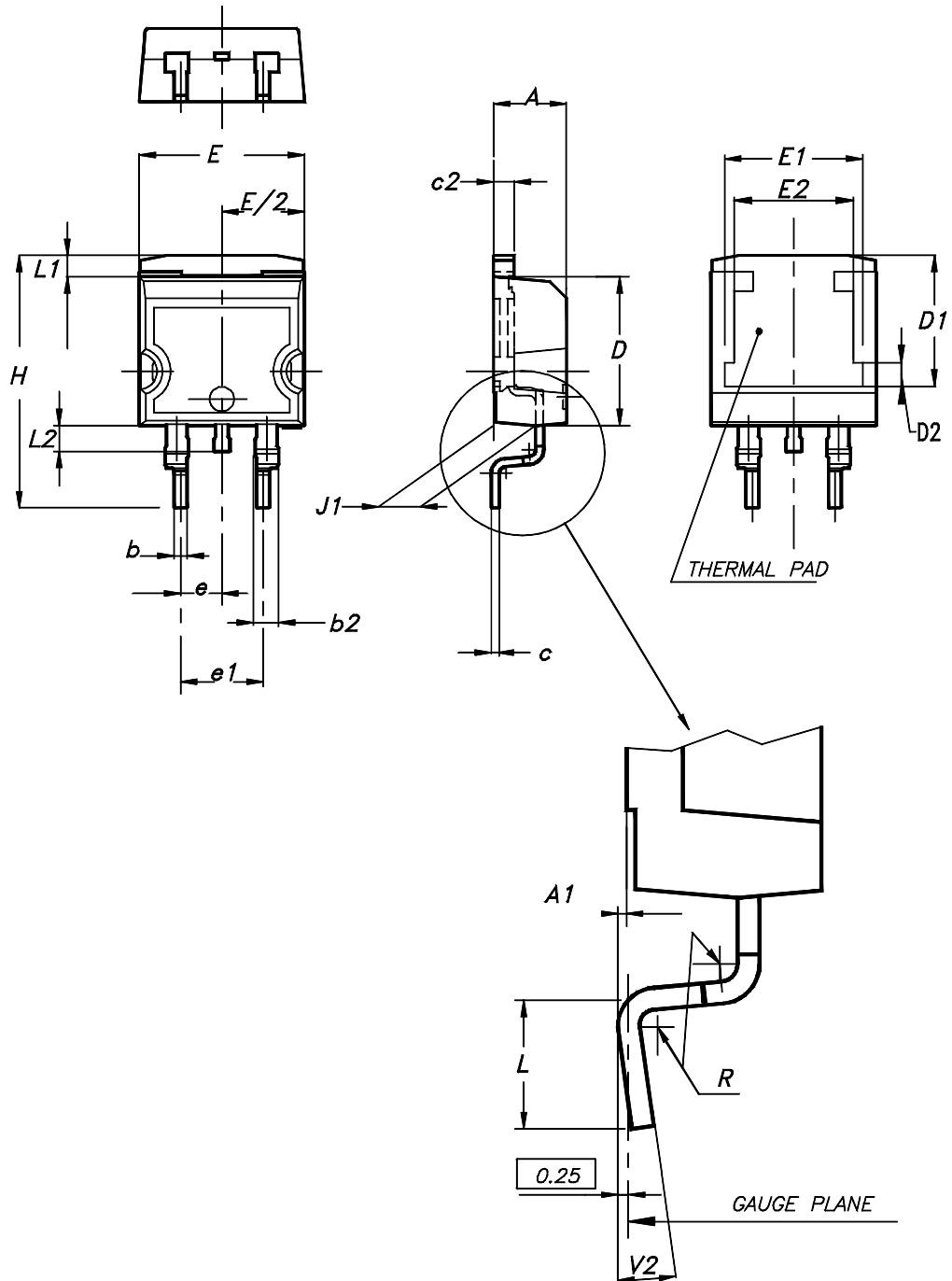

**Table 4. D<sup>2</sup>PAK package mechanical data**

Ref.	Dimensions			
	Millimeters		Inches	
	Min.	Max.	Min.	Max.
A	4.36	4.60	0.172	0.181
A1	0.00	0.25	0.000	0.010
b	0.70	0.93	0.028	0.037
b2	1.14	1.70	0.045	0.067
c	0.38	0.69	0.015	0.027
c2	1.19	1.36	0.047	0.053
D	8.60	9.35	0.339	0.368
D1	6.90	8.00	0.272	0.311
D2	1.10	1.50	0.043	0.060
E	10.00	10.55	0.394	0.415
E1	8.10	8.90	0.319	0.346
E2	6.85	7.25	0.266	0.282
e	2.54 typ.		0.100	
e1	4.88	5.28	0.190	0.205
H	15.00	15.85	0.591	0.624
J1	2.49	2.90	0.097	0.112
L	1.90	2.79	0.075	0.110
L1	1.27	1.65	0.049	0.065
L2	1.30	1.78	0.050	0.070
R	0.4 typ.		0.015	
V2	0°	8°	0°	8°

Figure 11. D<sup>2</sup>PAK Recommended footprint

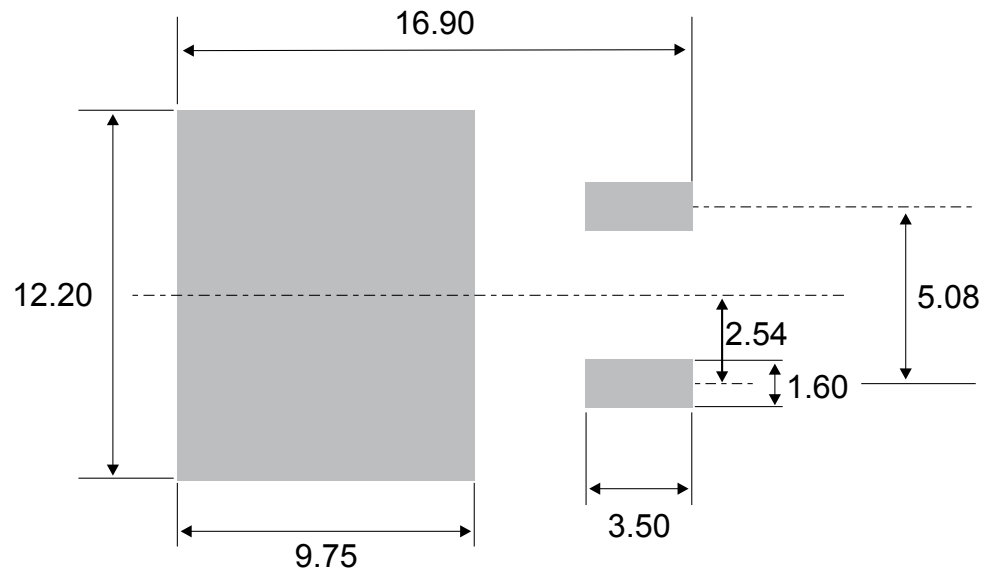

## 2.2 I<sup>2</sup>PAK package information

- Cooling method: by conduction (C)
- Epoxy meets UL 94,V0

Figure 12. I<sup>2</sup>PAK package outline

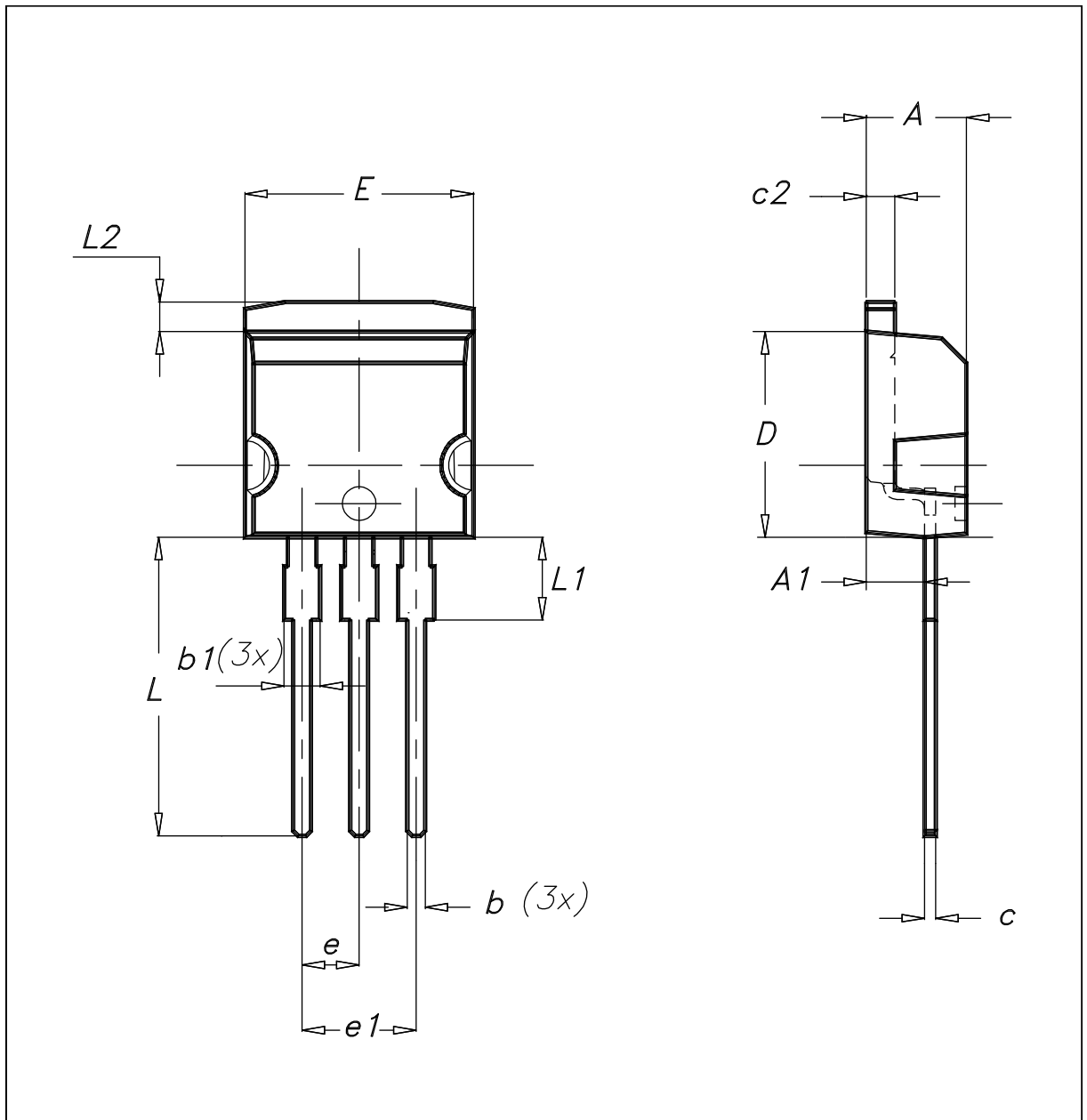

**Table 5. I<sup>2</sup>PAK package mechanical data**

Ref.	Dimensions			
	Millimeters		Inches	
	Min.	Max.	Min.	Max.
A	4.40	4.60	0.173	0.181
A1	2.40	2.72	0.094	0.107
b	0.61	0.88	0.024	0.035
b1	1.14	1.70	0.044	0.067
c	0.49	0.70	0.019	0.028
c2	1.23	1.32	0.048	0.052
D	8.95	9.35	0.352	0.368
e	2.40	2.70	0.094	0.106
e1	4.95	5.15	0.195	0.203
E	10.00	10.40	0.394	0.409
L	13.00	14.00	0.512	0.551
L1	3.50	3.93	0.138	0.155
L2	1.27	1.40	0.050	0.055

### 2.3 TO-220AB package information

- Cooling method: by conduction (C)
- Epoxy meets UL 94,V0
- Recommended torque value: 0.55 N·m
- Maximum torque value: 0.7 N·m

Figure 13. TO-220AB package outline

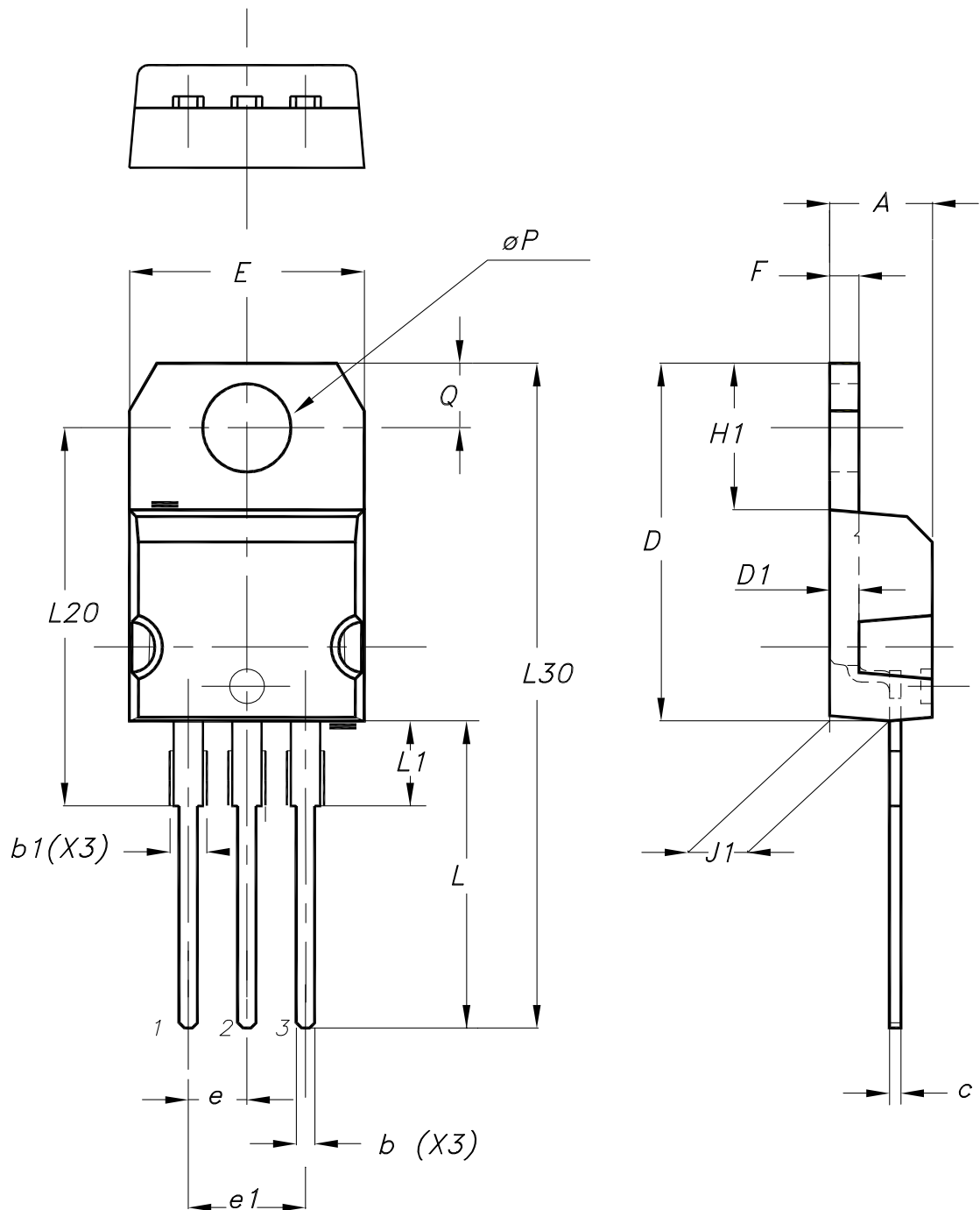

**Table 6. TO-220AB package mechanical data**

Ref.	Dimensions			
	Millimeters		Inches	
	Min.	Max.	Min.	Max.
A	4.40	4.60	0.173	0.181
b	0.61	0.88	0.240	0.035
b1	1.14	1.55	0.045	0.061
c	0.48	0.70	0.019	0.028
D	15.25	15.75	0.600	0.620
D1	1.27 typ.		0.050 typ.	
E	10.00	10.40	0.394	0.409
e	2.40	2.70	0.094	0.106
e1	4.95	5.15	0.195	0.203
F	1.23	1.32	0.048	0.052
H1	6.20	6.60	0.244	0.260
J1	2.40	2.72	0.094	0.107
L	13.00	14.00	0.512	0.551
L1	3.50	3.93	0.138	0.155
L20	16.40 typ.		0.646 typ.	
L30	28.90 typ.		1.138 typ.	
θP	3.75	3.85	0.148	0.152
Q	2.65	2.95	0.104	0.116

## 2.4 TO-220FPAB package information

- Cooling method: by conduction (C)
- Epoxy meets UL 94,V0
- Recommended torque value: 0.55 N·m
- Maximum torque value: 0.7 N·m

Figure 14. TO-220FPAB package outline

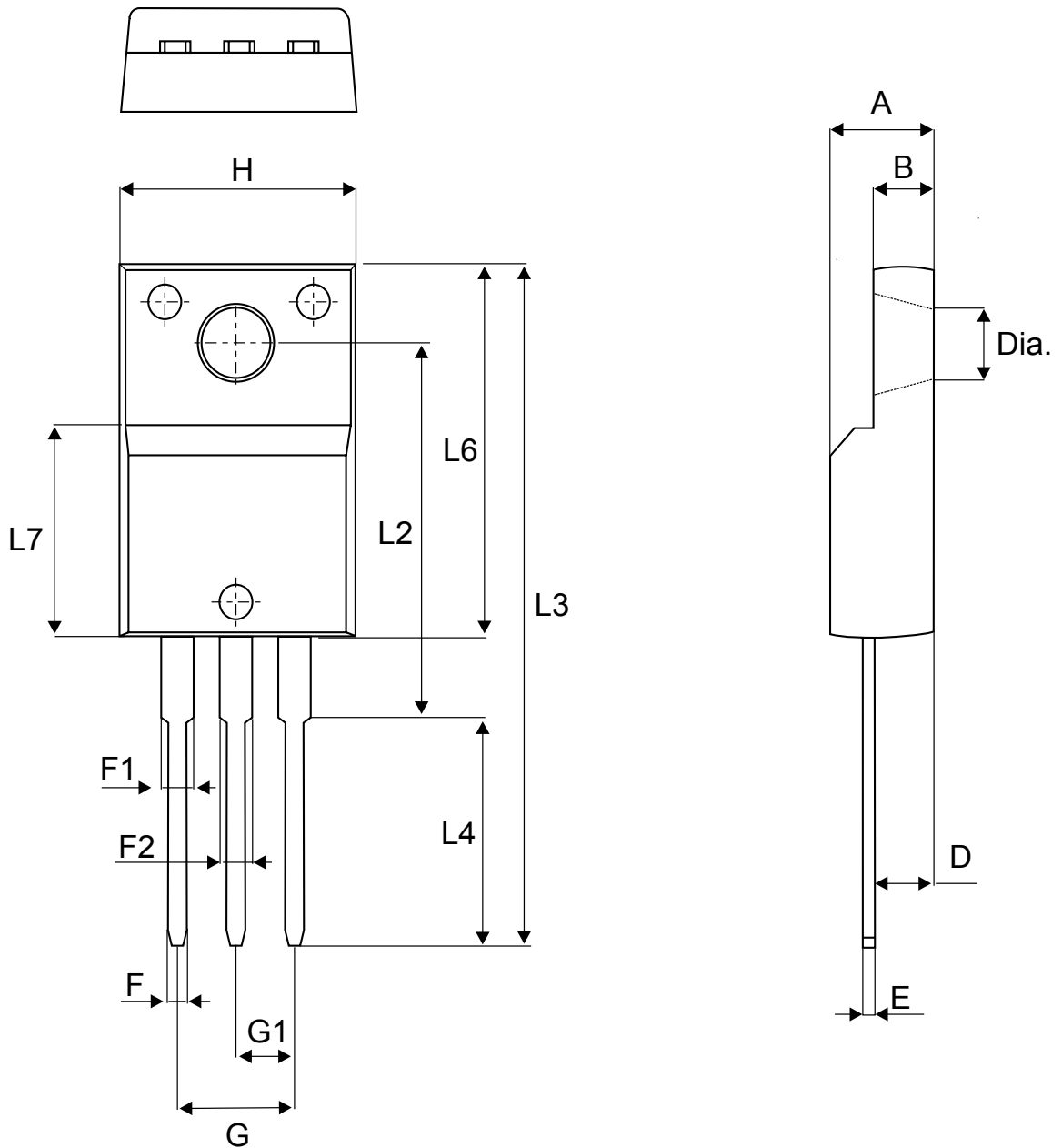

**Table 7. TO-220FPAB package mechanical data**

Ref.	Dimensions			
	Millimeters		Inches (for reference only)	
	Min.	Max.	Min.	Max.
A	4.40	4.60	0.1739	0.1818
B	2.5	2.7	0.0988	0.1067
D	2.50	2.75	0.0988	0.1087
E	0.45	0.70	0.0178	0.0277
F	0.75	1.0	0.0296	0.0395
F1	1.15	1.70	0.0455	0.0672
F2	1.15	1.70	0.0455	0.0672
G	4.95	5.20	0.1957	0.2055
G1	2.40	2.70	0.0949	0.1067
H	10.00	10.40	0.3953	0.4111
L2	16.00 typ.		0.6324 typ.	
L3	28.60	30.60	1.1304	1.2095
L4	9.80	10.6	0.3874	0.4190
L5	2.90	3.60	0.1146	0.1423
L6	15.90	16.40	0.6285	0.6482
L7	9.00	9.30	0.3557	0.3676
Dia	3.0	3.20	0.1186	0.1265

### 3 Ordering information

**Table 8. Ordering information**

Order code	Marking	Package	Weight	Base qty	Delivery mode
STPS20150CT	STPS20150CT	TO-220AB	1.95 g	50	Tube
STPS20150CFP	STPS20150CFP	TO-220FPAB	1.9 g	50	Tube
STPS20150CR	STPS20150CR	I <sup>2</sup> PAK	1.5 g	50	Tube
STPS20150CG-TR	STPS20150CG	D <sup>2</sup> PAK	1.38 g	1000	Tape and reel
STPS20150CG	STPS20150CG	D <sup>2</sup> PAK	1.38 g	50	Tube

## Revision history

**Table 9. Document revision history**

Date	Revision	Changes
Jul-2003	6D	Last update
11-May-2006	7	Reformatted to current standard. Added ECOPACK statement. Changed nF to pF in Figure 10.
07-Mar-2007	8	Reworked footnote to Table 1. Corrected typing error in Table 3.
28-Jan-2011	9	Updated weight in Table 9. Added warning paragraph above Table 6.
24-Aug-2015	10	Updated features, Table 1: "Device summary" and packages silhouette in cover page. Updated Section 1: "Characteristics" and Section 1.1: "Characteristics(curves)". Updated Section 2.2: "D <sup>2</sup> PAK package information".
08-Fev-2018	11	Updated I <sup>2</sup> PAK package information.
10-Apr-2018	12	Updated <a href="#">Table 5. I<sup>2</sup>PAK package mechanical data</a> .

**IMPORTANT NOTICE – PLEASE READ CAREFULLY**

STMicroelectronics NV and its subsidiaries (“ST”) reserve the right to make changes, corrections, enhancements, modifications, and improvements to ST products and/or to this document at any time without notice. Purchasers should obtain the latest relevant information on ST products before placing orders. ST products are sold pursuant to ST’s terms and conditions of sale in place at the time of order acknowledgement.

Purchasers are solely responsible for the choice, selection, and use of ST products and ST assumes no liability for application assistance or the design of Purchasers’ products.

No license, express or implied, to any intellectual property right is granted by ST herein.

Resale of ST products with provisions different from the information set forth herein shall void any warranty granted by ST for such product.



ST and the ST logo are trademarks of ST. All other product or service names are the property of their respective owners.

Information in this document supersedes and replaces information previously supplied in any prior versions of this document.

© 2018 STMicroelectronics – All rights reserved

## Looking for pricing, stock, or lifecycle information?

Click below to explore more details on WIN SOURCE:

-  [View STPS20150CFP](#) on WIN SOURCE
-  [STMicroelectronics](#) Information

## Optimize Your Supply Chain with WIN SOURCE Solutions

-  Global Sourcing Solution
-  Obsolete Management
-  Cost Control Management
-  Shortage Management
-  Alternative Solution
-  Excess Inventory Management