



**THE DATASHEET OF
74LVC2G66DC,125**



74LVC2G66

Bilateral switch

Rev. 11 — 30 October 2018

Product data sheet

1. General description

The 74LVC2G66 is a low-power, low-voltage, high-speed Si-gate CMOS device.

The 74LVC2G66 provides two single pole, single-throw analog switch functions. Each switch has two input/output terminals (nY and nZ) and an active HIGH enable input (nE). When nE is LOW, the analog switch is turned off.

Schmitt trigger action at the enable inputs makes the circuit tolerant of slower input rise and fall times across the entire V_{CC} range from 1.65 V to 5.5 V.

2. Features and benefits

- Wide supply voltage range from 1.65 V to 5.5 V
- Very low ON resistance:
 - 7.5 Ω (typical) at $V_{CC} = 2.7$ V
 - 6.5 Ω (typical) at $V_{CC} = 3.3$ V
 - 6 Ω (typical) at $V_{CC} = 5$ V
- Switch current capability of 32 mA
- High noise immunity
- CMOS low power consumption
- TTL interface compatibility at 3.3 V
- Latch-up performance meets requirements of JESD78 Class I
- ESD protection:
 - HBM JESD22-A114F exceeds 2000 V
 - MM JESD22-A115-A exceeds 200 V
- Enable input accepts voltages up to 5.5 V
- Multiple package options
- Specified from -40 °C to +85 °C and -40 °C to +125 °C

3. Ordering information

Table 1. Ordering information

Type number	Package			Version
	Temperature range	Name	Description	
74LVC2G66DP	-40 °C to +125 °C	TSSOP8	plastic thin shrink small outline package; 8 leads; body width 3 mm; lead length 0.5 mm	SOT505-2
74LVC2G66DC	-40 °C to +125 °C	VSSOP8	plastic very thin shrink small outline package; 8 leads; body width 2.3 mm	SOT765-1
74LVC2G66GT	-40 °C to +125 °C	XSON8	plastic extremely thin small outline package; no leads; 8 terminals; body 1 x 1.95 x 0.5 mm	SOT833-1
74LVC2G66GM	-40 °C to +125 °C	XQFN8	plastic, extremely thin quad flat package; no leads; 8 terminals; body 1.6 x 1.6 x 0.5 mm	SOT902-2
74LVC2G66GN	-40 °C to +125 °C	XSON8	extremely thin small outline package; no leads; 8 terminals; body 1.2 x 1.0 x 0.35 mm	SOT1116

4. Marking

Table 2. Marking codes

Type number	Marking code ^[1]
74LVC2G66DP	V66
74LVC2G66DC	V66
74LVC2G66GT	V66
74LVC2G66GM	V66
74LVC2G66GN	VL

[1] The pin 1 indicator is located on the lower left corner of the device, below the marking code.

5. Functional diagram

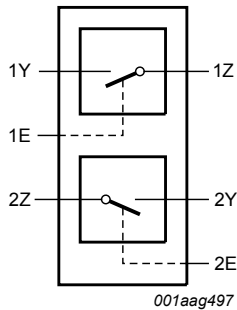

Fig. 1. Logic symbol

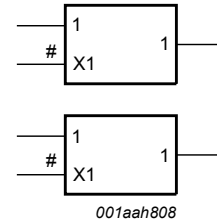

Fig. 2. IEC logic symbol

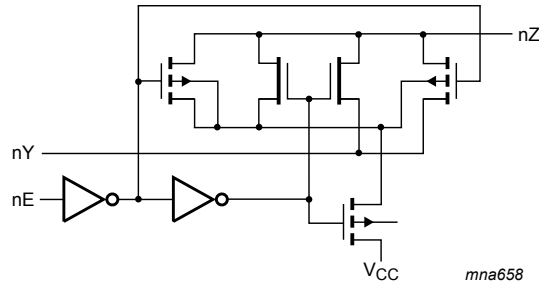
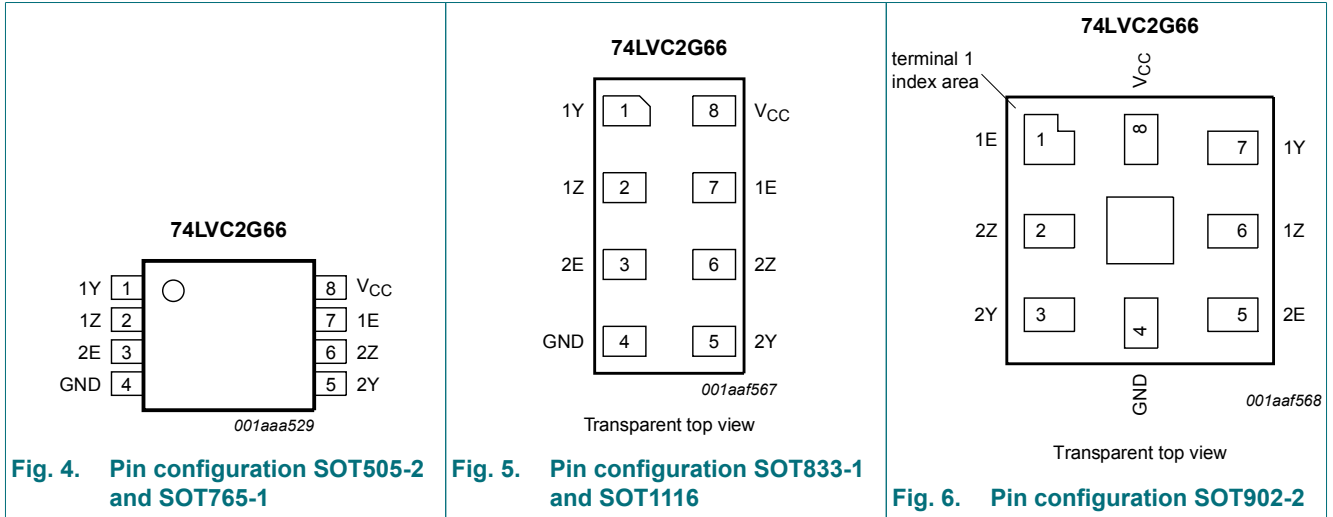

Fig. 3. Logic diagram (one switch)

6. Pinning information

6.1. Pinning



6.2. Pin description

Table 3. Pin description

Symbol	Pin		Description
	SOT505-2, SOT765-1, SOT833-1 and SOT1116	SOT902-2	
1Y	1	7	independent input or output
1Z	2	6	independent input or output
2E	3	5	enable input (active HIGH)
GND	4	4	ground (0 V)
2Y	5	3	independent input or output
2Z	6	2	independent input or output
1E	7	1	enable input (active HIGH)
V _{CC}	8	8	supply voltage

7. Functional description

Table 4. Function table

H = HIGH voltage level; L = LOW voltage level.

Input nE	Switch
L	OFF-state
H	ON-state

8. Limiting values

Table 5. Limiting values

In accordance with the Absolute Maximum Rating System (IEC 60134). Voltages are referenced to GND (ground = 0 V).

Symbol	Parameter	Conditions	Min	Max	Unit
V_{CC}	supply voltage		-0.5	+6.5	V
V_I	input voltage	[1]	-0.5	+6.5	V
I_{IK}	input clamping current	$V_I < -0.5 \text{ V}$ or $V_I > V_{CC} + 0.5 \text{ V}$	-50	-	mA
I_{SK}	switch clamping current	$V_I < -0.5 \text{ V}$ or $V_I > V_{CC} + 0.5 \text{ V}$	-	± 50	mA
V_{SW}	switch voltage	enable and disable mode [2]	-0.5	$V_{CC} + 0.5$	V
I_{SW}	switch current	$V_{SW} > -0.5 \text{ V}$ or $V_{SW} < V_{CC} + 0.5 \text{ V}$	-	± 50	mA
I_{CC}	supply current		-	100	mA
I_{GND}	ground current		-100	-	mA
T_{stg}	storage temperature		-65	+150	°C
P_{tot}	total power dissipation	$T_{amb} = -40 \text{ °C}$ to $+125 \text{ °C}$ [3]	-	250	mW

[1] The minimum input voltage rating may be exceeded if the input current rating is observed.

[2] The minimum and maximum switch voltage ratings may be exceeded if the switch clamping current rating is observed.

[3] For TSSOP8 package: above 55 °C the value of P_{tot} derates linearly with 2.5 mW/K.

For VSSOP8 package: above 110 °C the value of P_{tot} derates linearly with 8 mW/K.

For XSON8 and XQFN8 packages: above 118 °C the value of P_{tot} derates linearly with 7.8 mW/K.

9. Recommended operating conditions

Table 6. Operating conditions

Symbol	Parameter	Conditions	Min	Max	Unit
V_{CC}	supply voltage		1.65	5.5	V
V_I	input voltage		0	5.5	V
V_{SW}	switch voltage	[1][2]	0	V_{CC}	V
T_{amb}	ambient temperature		-40	+125	°C
$\Delta t/\Delta V$	input transition rise and fall rate	$V_{CC} = 1.65 \text{ V}$ to 2.7 V [3]	-	20	ns/V
		$V_{CC} = 2.7 \text{ V}$ to 5.5 V	-	10	ns/V

[1] To avoid sinking GND current from terminal nZ when switch current flows in terminal nY, the voltage drop across the bidirectional switch must not exceed 0.4 V. If the switch current flows into terminal nZ, no GND current will flow from terminal nY. In this case, there is no limit for the voltage drop across the switch.

[2] For overvoltage tolerant switch voltage capability, refer to 74LVCV2G66.

[3] Applies to control signal levels.

10. Static characteristics

Table 7. Static characteristics

At recommended operating conditions; voltages are referenced to GND (ground = 0 V).

Symbol	Parameter	Conditions	-40 °C to +85 °C			-40 °C to +125 °C		Unit
			Min	Typ[1]	Max	Min	Max	
V _{IH}	HIGH-level input voltage	V _{CC} = 1.65 V to 1.95 V	0.65×V _{CC}	-	-	0.65×V _{CC}	-	V
		V _{CC} = 2.3 V to 2.7 V	1.7	-	-	1.7	-	V
		V _{CC} = 2.7 V to 3.6 V	2.0	-	-	2.0	-	V
		V _{CC} = 4.5 V to 5.5 V	0.7×V _{CC}	-	-	0.7×V _{CC}	-	V
V _{IL}	LOW-level input voltage	V _{CC} = 1.65 V to 1.95 V	-	-	0.35×V _{CC}	-	0.35×V _{CC}	V
		V _{CC} = 2.3 V to 2.7 V	-	-	0.7	-	0.7	V
		V _{CC} = 2.7 V to 3.6 V	-	-	0.8	-	0.8	V
		V _{CC} = 4.5 V to 5.5 V	-	-	0.3×V _{CC}	-	0.3×V _{CC}	V
I _I	input leakage current	pin nE; V _I = 5.5 V or GND; [2] V _{CC} = 0 V to 5.5 V	-	±0.1	±1	-	±1	µA
I _{S(OFF)}	OFF-state leakage current	V _{CC} = 5.5 V; see Fig. 7. [2]	-	±0.1	±0.2	-	±0.5	µA
I _{S(ON)}	ON-state leakage current	V _{CC} = 5.5 V; see Fig. 8. [2]	-	±0.1	±1	-	±2	µA
I _{CC}	supply current	V _I = 5.5 V or GND; [2] V _{SW} = GND or V _{CC} ; V _{CC} = 1.65 V to 5.5 V	-	0.1	4	-	4	µA
ΔI _{CC}	additional supply current	pin nE; V _I = V _{CC} - 0.6 V; [2] V _{SW} = GND or V _{CC} ; V _{CC} = 5.5 V	-	5	500	-	500	µA
C _I	input capacitance		-	2.0	-	-	-	pF
C _{S(OFF)}	OFF-state capacitance		-	5.0	-	-	-	pF
C _{S(ON)}	ON-state capacitance		-	9.5	-	-	-	pF

- [1] All typical values are measured at T_{amb} = 25 °C.
- [2] These typical values are measured at V_{CC} = 3.3 V.

10.1. Test circuits

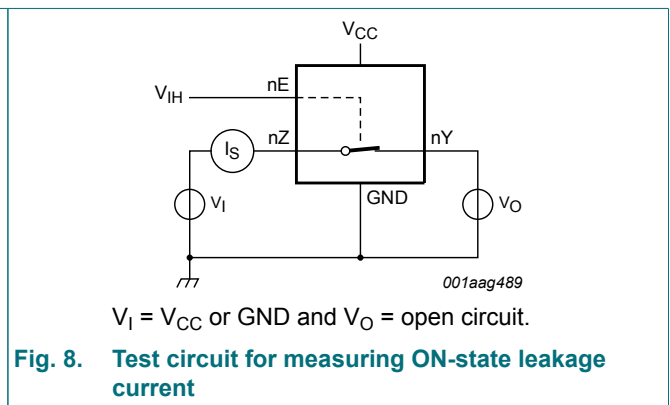
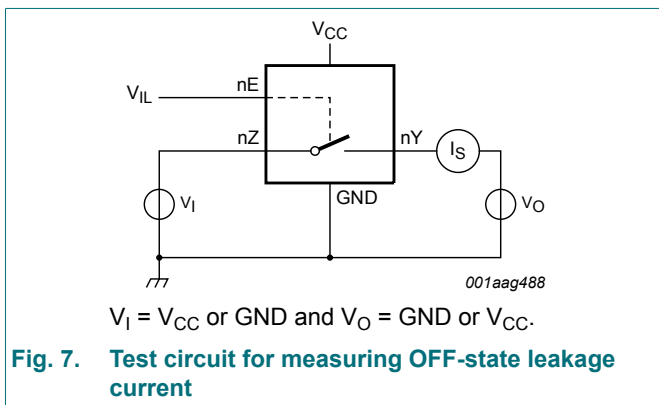

10.2. ON resistance

Table 8. ON resistance

At recommended operating conditions; voltages are referenced to GND (ground 0 V); for graphs see [Fig. 10](#) to [Fig. 15](#).

Symbol	Parameter	Conditions	-40 °C to +85 °C			-40 °C to +125 °C		Unit
			Min	Typ[1]	Max	Min	Max	
R _{ON(peak)}	ON resistance (peak)	V _I = GND to V _{CC} ; see Fig. 9 .						
		I _{SW} = 4 mA; V _{CC} = 1.65 V to 1.95 V	-	34.0	130	-	195	Ω
		I _{SW} = 8 mA; V _{CC} = 2.3 V to 2.7 V	-	12.0	30	-	45	Ω
		I _{SW} = 12 mA; V _{CC} = 2.7 V	-	10.4	25	-	38	Ω
		I _{SW} = 24 mA; V _{CC} = 3 V to 3.6 V	-	7.8	20	-	30	Ω
		I _{SW} = 32 mA; V _{CC} = 4.5 V to 5.5 V	-	6.2	15	-	23	Ω
R _{ON(rail)}	ON resistance (rail)	V _I = GND; see Fig. 9						
		I _{SW} = 4 mA; V _{CC} = 1.65 V to 1.95 V	-	8.2	18	-	27	Ω
		I _{SW} = 8 mA; V _{CC} = 2.3 V to 2.7 V	-	7.1	16	-	24	Ω
		I _{SW} = 12 mA; V _{CC} = 2.7 V	-	6.9	14	-	21	Ω
		I _{SW} = 24 mA; V _{CC} = 3 V to 3.6 V	-	6.5	12	-	18	Ω
		I _{SW} = 32 mA; V _{CC} = 4.5 V to 5.5 V	-	5.8	10	-	15	Ω
		V _I = V _{CC} ; see Fig. 9						
		I _{SW} = 4 mA; V _{CC} = 1.65 V to 1.95 V	-	10.4	30	-	45	Ω
		I _{SW} = 8 mA; V _{CC} = 2.3 V to 2.7 V	-	7.6	20	-	30	Ω
		I _{SW} = 12 mA; V _{CC} = 2.7 V	-	7.0	18	-	27	Ω
		I _{SW} = 24 mA; V _{CC} = 3 V to 3.6 V	-	6.1	15	-	23	Ω
		I _{SW} = 32 mA; V _{CC} = 4.5 V to 5.5 V	-	4.9	10	-	15	Ω
		R _{ON(flat)}	ON resistance (flatness)	V _I = GND to V _{CC} [2]				
I _{SW} = 4 mA; V _{CC} = 1.65 V to 1.95 V	-			26.0	-	-	-	Ω
I _{SW} = 8 mA; V _{CC} = 2.3 V to 2.7 V	-			5.0	-	-	-	Ω
I _{SW} = 12 mA; V _{CC} = 2.7 V	-			3.5	-	-	-	Ω
I _{SW} = 24 mA; V _{CC} = 3 V to 3.6 V	-			2.0	-	-	-	Ω
I _{SW} = 32 mA; V _{CC} = 4.5 V to 5.5 V	-			1.5	-	-	-	Ω

[1] Typical values are measured at T_{amb} = 25 °C and nominal V_{CC}.

[2] Flatness is defined as the difference between the maximum and minimum value of ON resistance measured at identical V_{CC} and temperature.

10.3. ON resistance test circuit and graphs

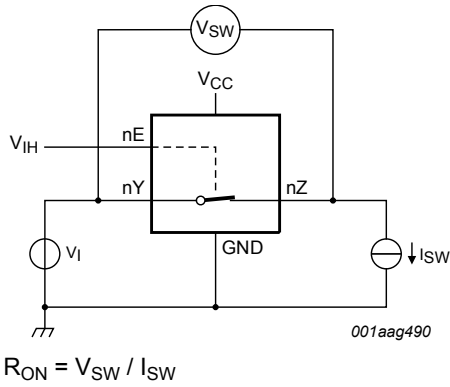
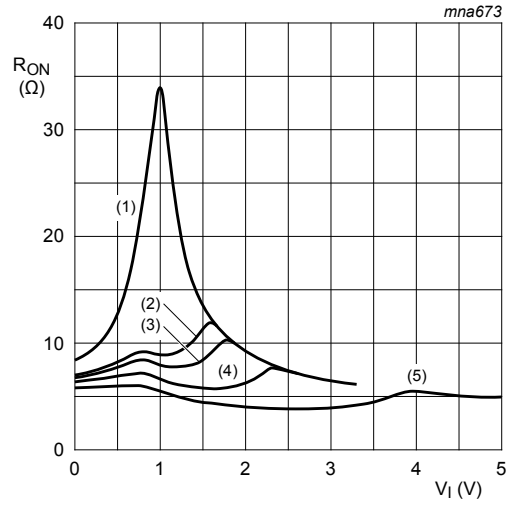
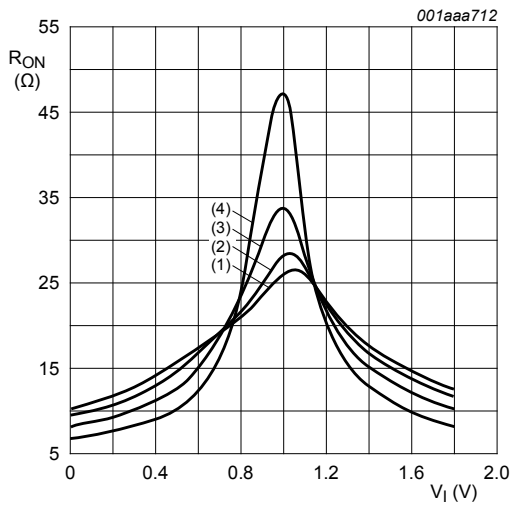

Fig. 9. Test circuit for measuring ON resistance



- (1) $V_{CC} = 1.8 \text{ V}$
- (2) $V_{CC} = 2.5 \text{ V}$
- (3) $V_{CC} = 2.7 \text{ V}$
- (4) $V_{CC} = 3.3 \text{ V}$
- (5) $V_{CC} = 5.0 \text{ V}$

Fig. 10. Typical ON resistance as a function of input voltage; $T_{amb} = 25 \text{ }^\circ\text{C}$



- (1) $T_{amb} = 125 \text{ }^\circ\text{C}$
- (2) $T_{amb} = 85 \text{ }^\circ\text{C}$
- (3) $T_{amb} = 25 \text{ }^\circ\text{C}$
- (4) $T_{amb} = -40 \text{ }^\circ\text{C}$

Fig. 11. ON resistance as a function of input voltage; $V_{CC} = 1.8 \text{ V}$

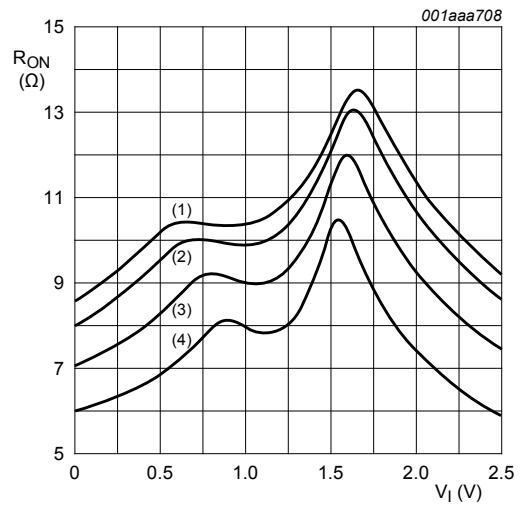

- (1) $T_{amb} = 125 \text{ }^\circ\text{C}$
- (2) $T_{amb} = 85 \text{ }^\circ\text{C}$
- (3) $T_{amb} = 25 \text{ }^\circ\text{C}$
- (4) $T_{amb} = -40 \text{ }^\circ\text{C}$

Fig. 12. ON resistance as a function of input voltage; $V_{CC} = 2.5 \text{ V}$

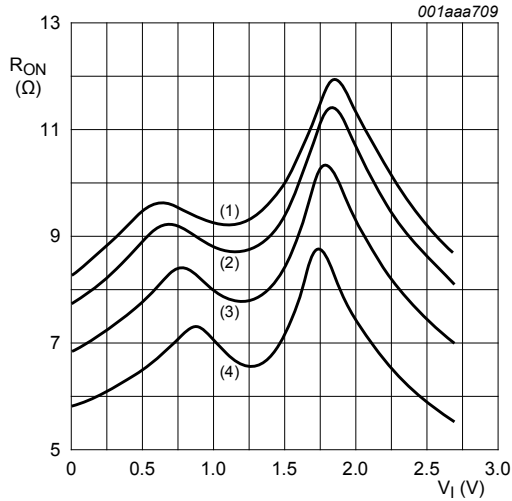

- (1) $T_{amb} = 125\text{ }^{\circ}\text{C}$
- (2) $T_{amb} = 85\text{ }^{\circ}\text{C}$
- (3) $T_{amb} = 25\text{ }^{\circ}\text{C}$
- (4) $T_{amb} = -40\text{ }^{\circ}\text{C}$

Fig. 13. ON resistance as a function of input voltage; $V_{CC} = 2.7\text{ V}$

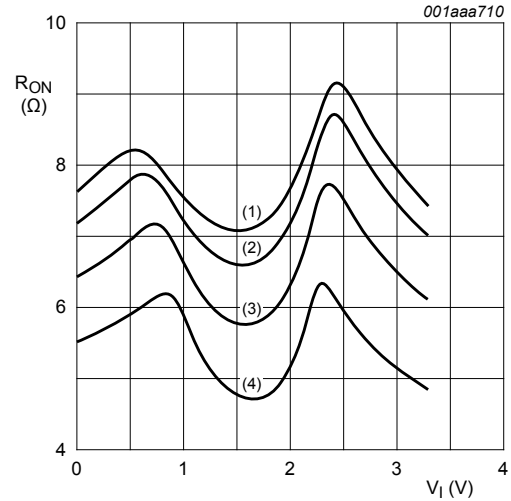

- (1) $T_{amb} = 125\text{ }^{\circ}\text{C}$
- (2) $T_{amb} = 85\text{ }^{\circ}\text{C}$
- (3) $T_{amb} = 25\text{ }^{\circ}\text{C}$
- (4) $T_{amb} = -40\text{ }^{\circ}\text{C}$

Fig. 14. ON resistance as a function of input voltage; $V_{CC} = 3.3\text{ V}$

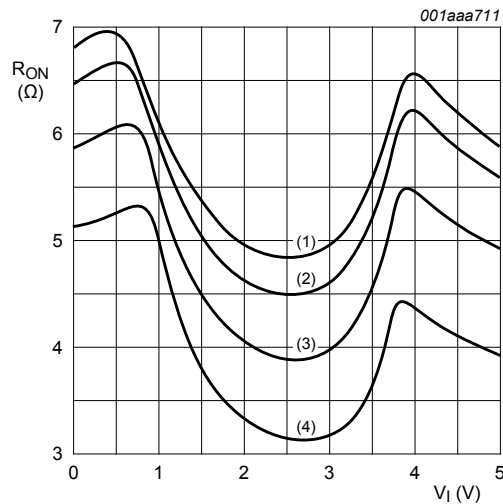

- (1) $T_{amb} = 125\text{ }^{\circ}\text{C}$
- (2) $T_{amb} = 85\text{ }^{\circ}\text{C}$
- (3) $T_{amb} = 25\text{ }^{\circ}\text{C}$
- (4) $T_{amb} = -40\text{ }^{\circ}\text{C}$

Fig. 15. ON resistance as a function of input voltage; $V_{CC} = 5.0\text{ V}$

11. Dynamic characteristics

Table 9. Dynamic characteristics

At recommended operating conditions; voltages are referenced to GND (ground = 0 V); for test circuit see Fig. 18.

Symbol	Parameter	Conditions	-40 °C to +85 °C			-40 °C to +125 °C		Unit
			Min	Typ[1]	Max	Min	Max	
t _{pd}	propagation delay	nY to nZ or nZ to nY; see Fig. 16. [2][3]						
		V _{CC} = 1.65 V to 1.95 V	-	0.8	2.0	-	3.0	ns
		V _{CC} = 2.3 V to 2.7 V	-	0.4	1.2	-	2.0	ns
		V _{CC} = 2.7 V	-	0.4	1.0	-	1.5	ns
		V _{CC} = 3.0 V to 3.6 V	-	0.3	0.8	-	1.5	ns
		V _{CC} = 4.5 V to 5.5 V	-	0.2	0.6	-	1.0	ns
t _{en}	enable time	nE to nY or nZ; see Fig. 17. [4]						
		V _{CC} = 1.65 V to 1.95 V	1.0	4.6	10	1.0	13.0	ns
		V _{CC} = 2.3 V to 2.7 V	1.0	2.7	5.6	1.0	7.5	ns
		V _{CC} = 2.7 V	1.0	2.7	5.0	1.0	6.5	ns
		V _{CC} = 3.0 V to 3.6 V	1.0	2.4	4.4	1.0	6.0	ns
		V _{CC} = 4.5 V to 5.5 V	1.0	1.8	3.9	1.0	5.0	ns
t _{dis}	disable time	nE to nY or nZ; see Fig. 17. [5]						
		V _{CC} = 1.65 V to 1.95 V	1.0	3.8	9.0	1.0	11.5	ns
		V _{CC} = 2.3 V to 2.7 V	1.0	2.1	5.5	1.0	7.0	ns
		V _{CC} = 2.7 V	1.0	3.5	6.5	1.0	8.5	ns
		V _{CC} = 3.0 V to 3.6 V	1.0	3.0	6.0	1.0	8.0	ns
		V _{CC} = 4.5 V to 5.5 V	1.0	2.2	5.0	1.0	6.5	ns
C _{PD}	power dissipation capacitance	C _L = 50 pF; f _i = 10 MHz; V _I = GND to V _{CC} [6]						
		V _{CC} = 2.5 V	-	9.0	-	-	-	pF
		V _{CC} = 3.3 V	-	11.0	-	-	-	pF
		V _{CC} = 5.0 V	-	15.7	-	-	-	pF

[1] Typical values are measured at T_{amb} = 25 °C and nominal V_{CC}.

[2] t_{pd} is the same as t_{PLH} and t_{PHL}.

[3] Propagation delay is the calculated RC time constant of the typical ON resistance of the switch and the specified capacitance when driven by an ideal voltage source (zero output impedance).

[4] t_{en} is the same as t_{PZH} and t_{PZL}.

[5] t_{dis} is the same as t_{PLZ} and t_{PHZ}.

[6] C_{PD} is used to determine the dynamic power dissipation (P_D in μW).

$$P_D = C_{PD} \times V_{CC}^2 \times f_i \times N + \sum \{(C_L + C_{S(ON)}) \times V_{CC}^2 \times f_o\} \text{ where:}$$

f_i = input frequency in MHz; f_o = output frequency in MHz;

C_L = output load capacitance in pF;

C_{S(ON)} = maximum ON-state switch capacitance in pF;

V_{CC} = supply voltage in V;

N = number of inputs switching;

$\sum \{(C_L + C_{S(ON)}) \times V_{CC}^2 \times f_o\}$ = sum of the outputs.

11.1. Waveforms and test circuit

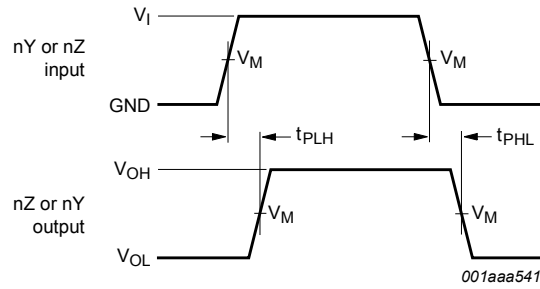

Measurement points are given in [Table 10](#).

Logic levels: V_{OL} and V_{OH} are typical output voltage levels that occur with the output load.

Fig. 16. Input (nY or nZ) to output (nZ or nY) propagation delays

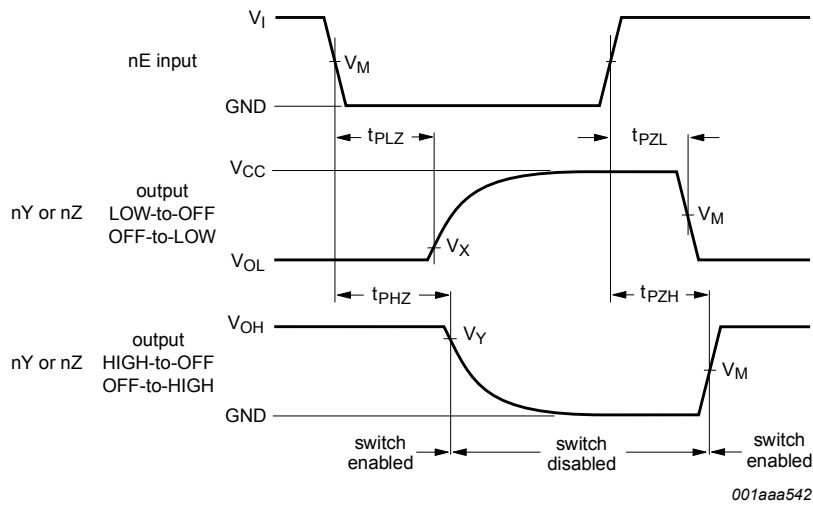

Measurement points are given in [Table 10](#).

Logic levels: V_{OL} and V_{OH} are typical output voltage levels that occur with the output load.

Fig. 17. Enable and disable times

Table 10. Measurement points

Supply voltage	Input	Output		
V_{CC}	V_M	V_M	V_X	V_Y
1.65 V to 1.95 V	$0.5 \times V_{CC}$	$0.5 \times V_{CC}$	$V_{OL} + 0.15 \text{ V}$	$V_{OH} - 0.15 \text{ V}$
2.3 V to 2.7 V	$0.5 \times V_{CC}$	$0.5 \times V_{CC}$	$V_{OL} + 0.15 \text{ V}$	$V_{OH} - 0.15 \text{ V}$
2.7 V	1.5 V	1.5 V	$V_{OL} + 0.3 \text{ V}$	$V_{OH} - 0.3 \text{ V}$
3.0 V to 3.6 V	1.5 V	1.5 V	$V_{OL} + 0.3 \text{ V}$	$V_{OH} - 0.3 \text{ V}$
4.5 V to 5.5 V	$0.5 \times V_{CC}$	$0.5 \times V_{CC}$	$V_{OL} + 0.3 \text{ V}$	$V_{OH} - 0.3 \text{ V}$

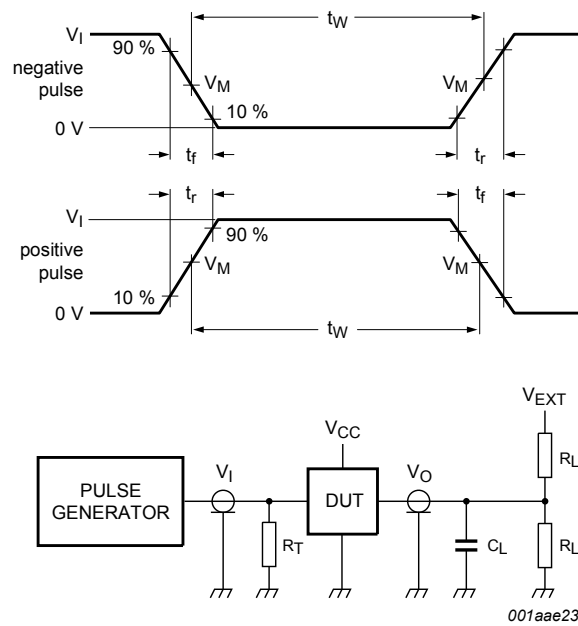

Test data is given in [Table 11](#).

Definitions test circuit:

R_T = Termination resistance should be equal to output impedance Z_o of the pulse generator.

C_L = Load capacitance including jig and probe capacitance.

R_L = Load resistance.

V_{EXT} = External voltage for measuring switching times.

Fig. 18. Test circuit for measuring switching times

Table 11. Test data

Supply voltage	Input		Load		V_{EXT}		
V_{CC}	V_I	t_r, t_f	C_L	R_L	t_{PLH}, t_{PHL}	t_{PZH}, t_{PHZ}	t_{PZL}, t_{PLZ}
1.65 V to 1.95 V	V_{CC}	≤ 2.0 ns	30 pF	1 k Ω	open	GND	$2 \times V_{CC}$
2.3 V to 2.7 V	V_{CC}	≤ 2.0 ns	30 pF	500 Ω	open	GND	$2 \times V_{CC}$
2.7 V	2.7 V	≤ 2.5 ns	50 pF	500 Ω	open	GND	6 V
3.0 V to 3.6 V	2.7 V	≤ 2.5 ns	50 pF	500 Ω	open	GND	6 V
4.5 V to 5.5 V	V_{CC}	≤ 2.5 ns	50 pF	500 Ω	open	GND	$2 \times V_{CC}$

11.2. Additional dynamic characteristics

Table 12. Additional dynamic characteristics

At recommended operating conditions; voltages are referenced to GND (ground = 0 V); $T_{amb} = 25\text{ }^{\circ}\text{C}$.

Symbol	Parameter	Conditions	Min	Typ	Max	Unit
THD	total harmonic distortion	$R_L = 10\text{ k}\Omega$; $C_L = 50\text{ pF}$; $f_i = 1\text{ kHz}$; see Fig. 19.				
		$V_{CC} = 1.65\text{ V}$	-	0.032	-	%
		$V_{CC} = 2.3\text{ V}$	-	0.008	-	%
		$V_{CC} = 3.0\text{ V}$	-	0.006	-	%
		$V_{CC} = 4.5\text{ V}$	-	0.005	-	%
		$R_L = 10\text{ k}\Omega$; $C_L = 50\text{ pF}$; $f_i = 10\text{ kHz}$; see Fig. 19.				
		$V_{CC} = 1.65\text{ V}$	-	0.068	-	%
		$V_{CC} = 2.3\text{ V}$	-	0.009	-	%
		$V_{CC} = 3.0\text{ V}$	-	0.008	-	%
		$V_{CC} = 4.5\text{ V}$	-	0.006	-	%
$f_{(-3\text{dB})}$	-3 dB frequency response	$R_L = 600\text{ }\Omega$; $C_L = 50\text{ pF}$; see Fig. 20.				
		$V_{CC} = 1.65\text{ V}$	-	135	-	MHz
		$V_{CC} = 2.3\text{ V}$	-	145	-	MHz
		$V_{CC} = 3.0\text{ V}$	-	150	-	MHz
		$V_{CC} = 4.5\text{ V}$	-	155	-	MHz
		$R_L = 50\text{ }\Omega$; $C_L = 10\text{ pF}$; see Fig. 20.				
		$V_{CC} = 1.65\text{ V}$	-	200	-	MHz
		$V_{CC} = 2.3\text{ V}$	-	350	-	MHz
		$V_{CC} = 3.0\text{ V}$	-	410	-	MHz
		$V_{CC} = 4.5\text{ V}$	-	440	-	MHz
		$R_L = 50\text{ }\Omega$; $C_L = 5\text{ pF}$; see Fig. 20.				
		$V_{CC} = 1.65\text{ V}$	-	> 500	-	MHz
		$V_{CC} = 2.3\text{ V}$	-	> 500	-	MHz
		$V_{CC} = 3.0\text{ V}$	-	> 500	-	MHz
$V_{CC} = 4.5\text{ V}$	-	> 500	-	MHz		
α_{iso}	isolation (OFF-state)	$R_L = 600\text{ }\Omega$; $C_L = 50\text{ pF}$; $f_i = 1\text{ MHz}$; see Fig. 21.				
		$V_{CC} = 1.65\text{ V}$	-	-46	-	dB
		$V_{CC} = 2.3\text{ V}$	-	-46	-	dB
		$V_{CC} = 3.0\text{ V}$	-	-46	-	dB
		$V_{CC} = 4.5\text{ V}$	-	-46	-	dB
		$R_L = 50\text{ }\Omega$; $C_L = 5\text{ pF}$; $f_i = 1\text{ MHz}$; see Fig. 21.				
		$V_{CC} = 1.65\text{ V}$	-	-37	-	dB
		$V_{CC} = 2.3\text{ V}$	-	-37	-	dB
		$V_{CC} = 3.0\text{ V}$	-	-37	-	dB
		$V_{CC} = 4.5\text{ V}$	-	-37	-	dB

Symbol	Parameter	Conditions	Min	Typ	Max	Unit	
V _{ct}	crosstalk voltage	between digital inputs and switch; R _L = 600 Ω; C _L = 50 pF; f _i = 1 MHz; t _r = t _f = 2 ns; see Fig. 22.					
		V _{CC} = 1.65 V	-	-	-	mV	
		V _{CC} = 2.3 V	-	91	-	mV	
		V _{CC} = 3.0 V	-	119	-	mV	
		V _{CC} = 4.5 V	-	205	-	mV	
Xtalk	crosstalk	between switches; R _L = 600 Ω; C _L = 50 pF; f _i = 1 MHz; see Fig. 23.					
		V _{CC} = 1.65 V	-	-	-	dB	
		V _{CC} = 2.3 V	-	-56	-	dB	
		V _{CC} = 3.0 V	-	-56	-	dB	
		V _{CC} = 4.5 V	-	-56	-	dB	
		between switches; R _L = 50 Ω; C _L = 5 pF; f _i = 1 MHz; see Fig. 23.					
		V _{CC} = 1.65 V	-	-	-	dB	
		V _{CC} = 2.3 V	-	-29	-	dB	
		V _{CC} = 3.0 V	-	-28	-	dB	
		V _{CC} = 4.5 V	-	-28	-	dB	
Q _{inj}	charge injection	C _L = 0.1 nF; V _{gen} = 0 V; R _{gen} = 0 Ω; f _i = 1 MHz; R _L = 1 MΩ; see Fig. 24.					
		V _{CC} = 1.8 V	-	3.3	-	pC	
		V _{CC} = 2.5 V	-	4.1	-	pC	
		V _{CC} = 3.3 V	-	5.0	-	pC	
		V _{CC} = 4.5 V	-	6.4	-	pC	
		V _{CC} = 5.5 V	-	7.5	-	pC	

11.3. Test circuits

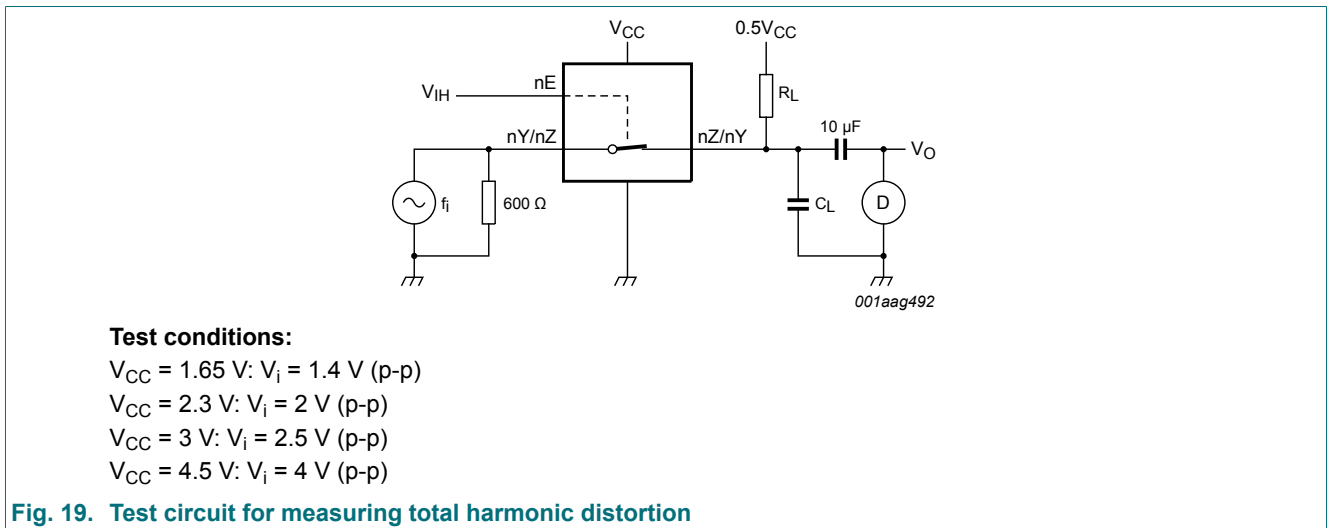
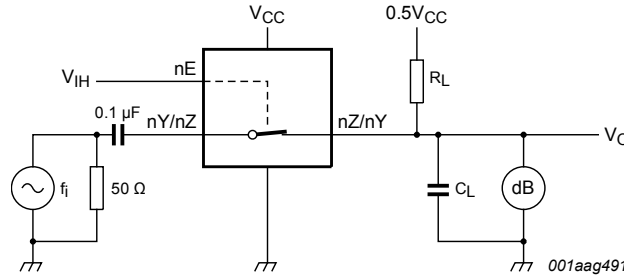
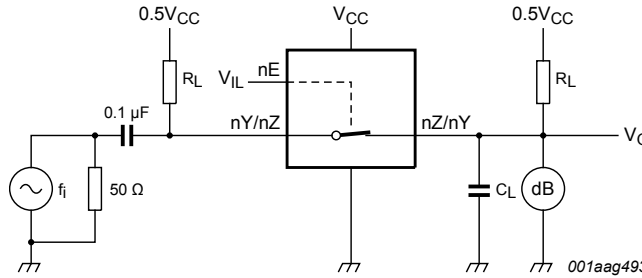

Fig. 19. Test circuit for measuring total harmonic distortion



Adjust f_i voltage to obtain 0 dBm level at output. Increase f_i frequency until dB meter reads -3 dB.

Fig. 20. Test circuit for measuring the frequency response when switch is in ON-state



Adjust f_i voltage to obtain 0 dBm level at input.

Fig. 21. Test circuit for measuring isolation (OFF-state)

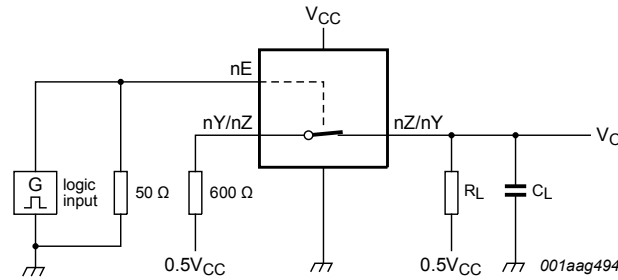
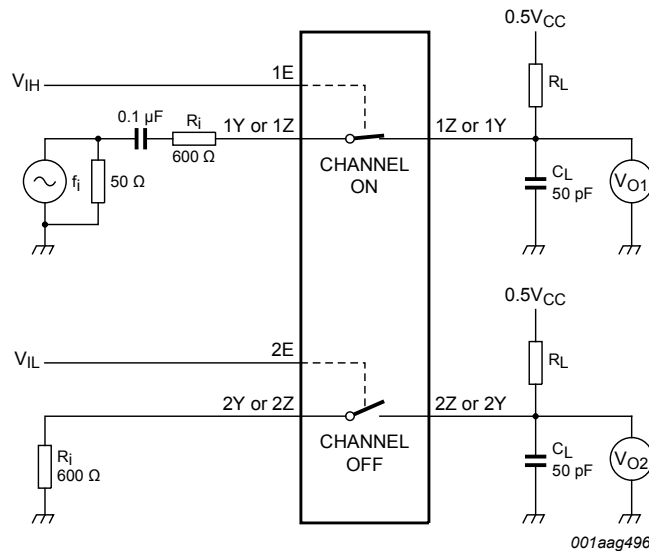
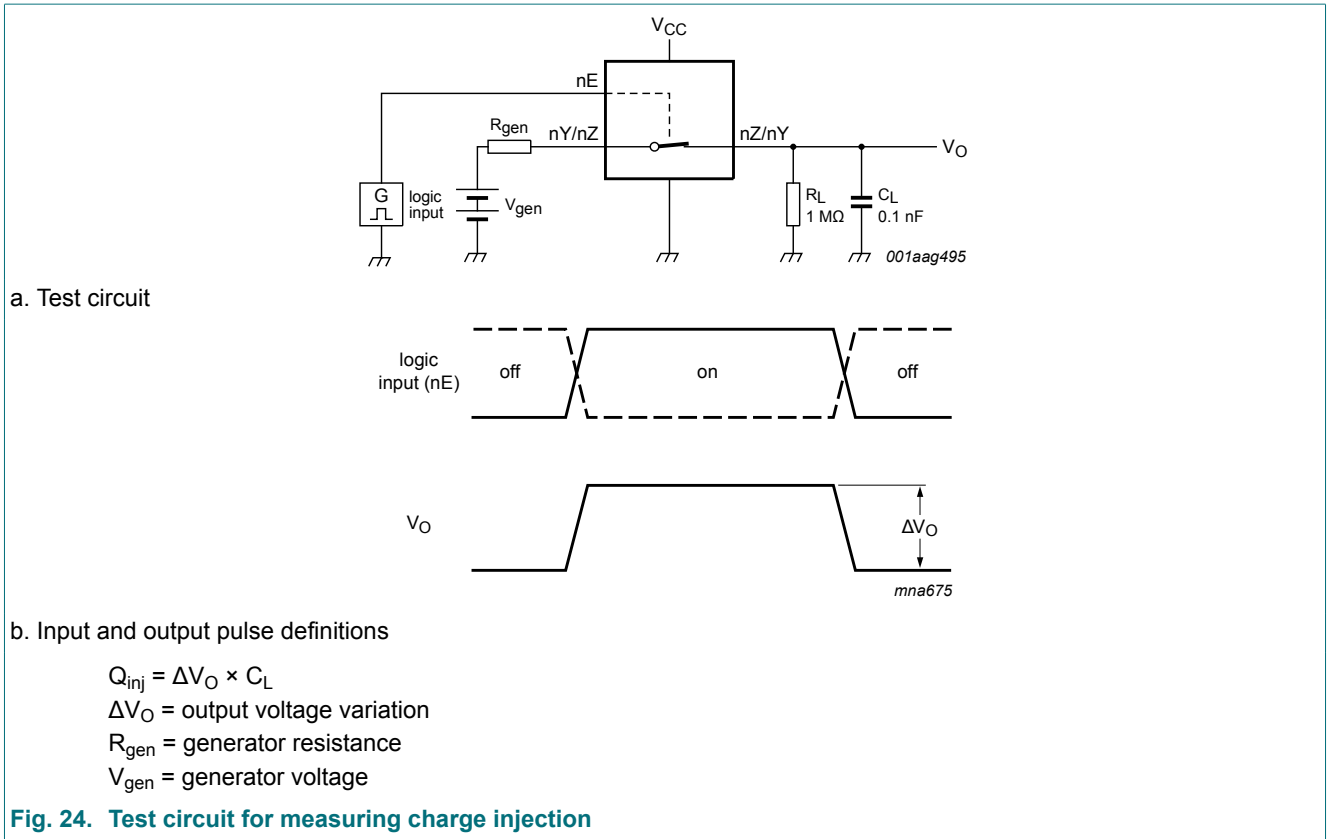

Fig. 22. Test circuit for measuring crosstalk voltage (between digital inputs and switch)



$20 \log_{10} (V_{O2} / V_{O1})$ or $20 \log_{10} (V_{O1} / V_{O2})$.

Fig. 23. Test circuit for measuring crosstalk between switches



12. Package outline

TSSOP8: plastic thin shrink small outline package; 8 leads; body width 3 mm; lead length 0.5 mm SOT505-2

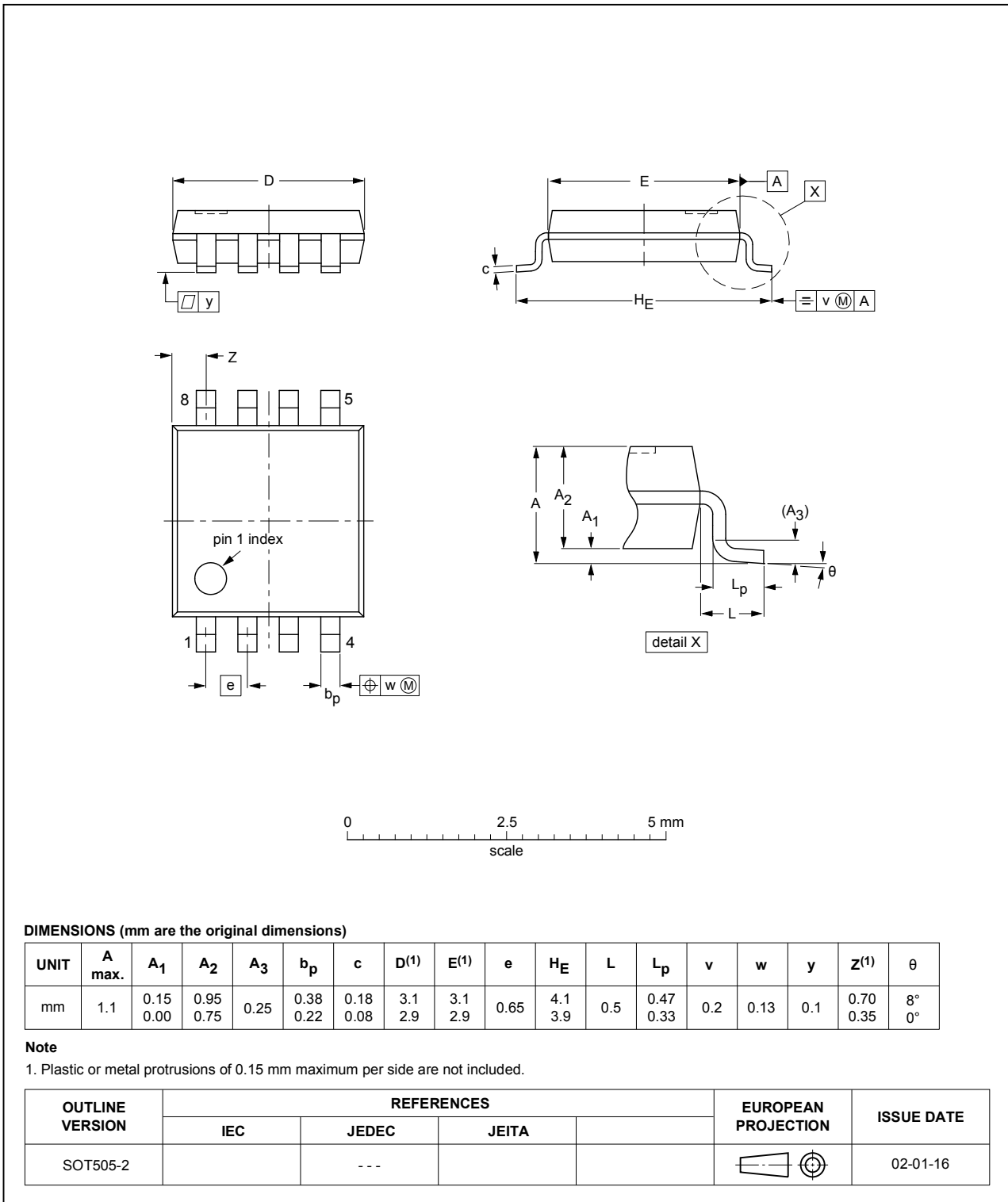

Fig. 25. Package outline SOT505-2 (TSSOP8)

VSSOP8: plastic very thin shrink small outline package; 8 leads; body width 2.3 mm

SOT765-1

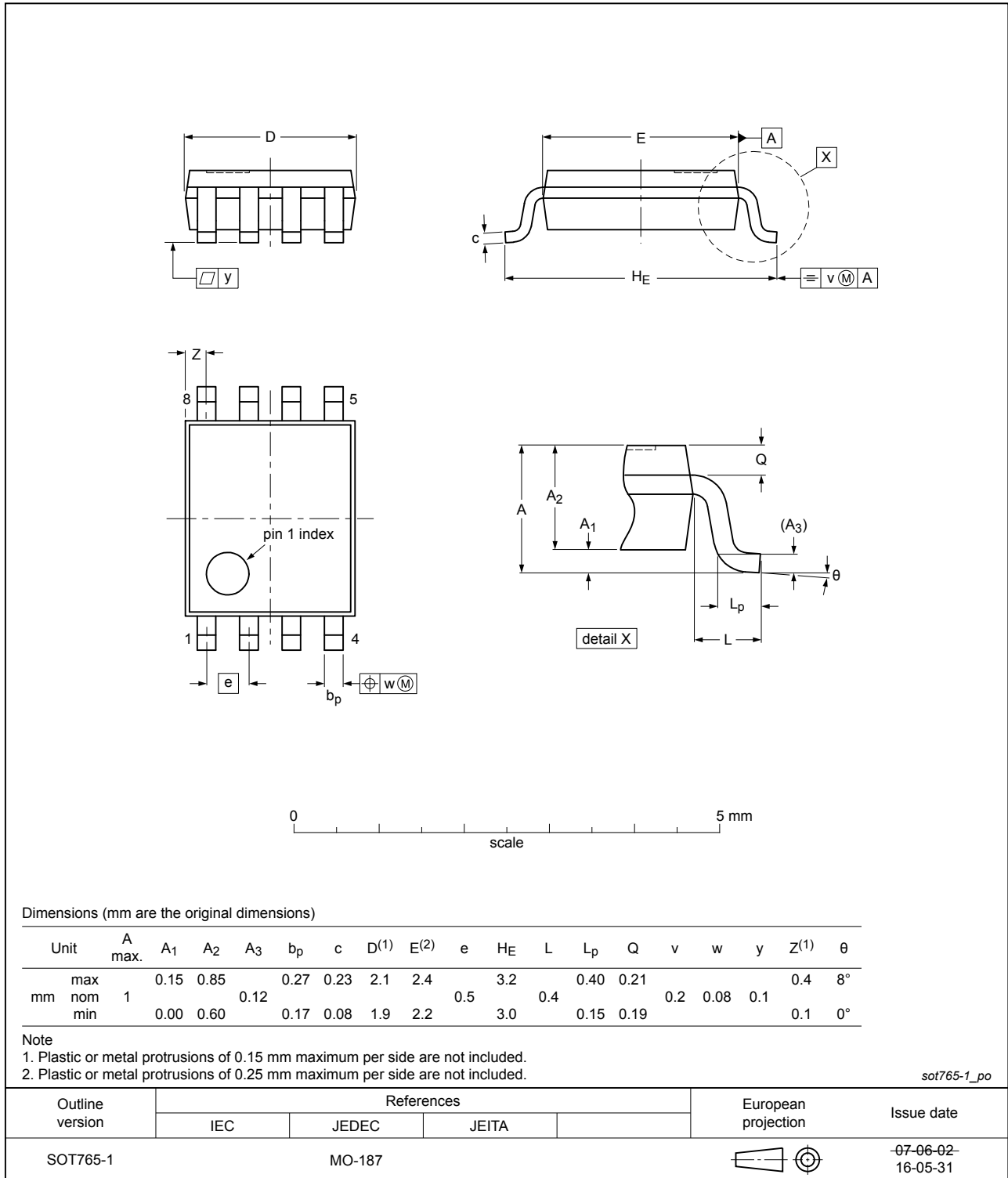

Fig. 26. Package outline SOT765-1 (VSSOP8)

XSON8: plastic extremely thin small outline package; no leads; 8 terminals; body 1 x 1.95 x 0.5 mm

SOT833-1

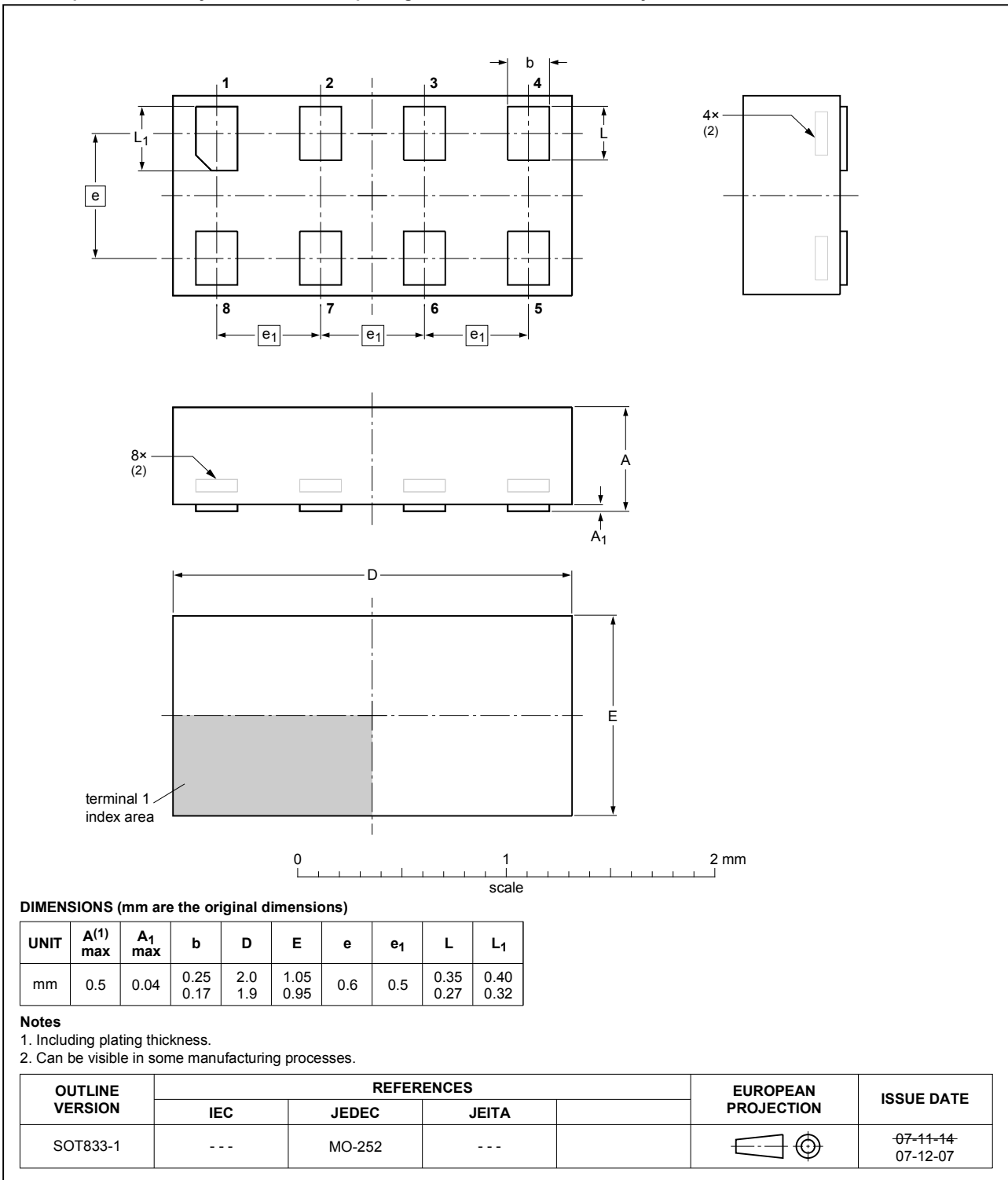

Fig. 27. Package outline SOT833-1 (XSON8)

XQFN8: plastic, extremely thin quad flat package; no leads;
8 terminals; body 1.6 x 1.6 x 0.5 mm

SOT902-2

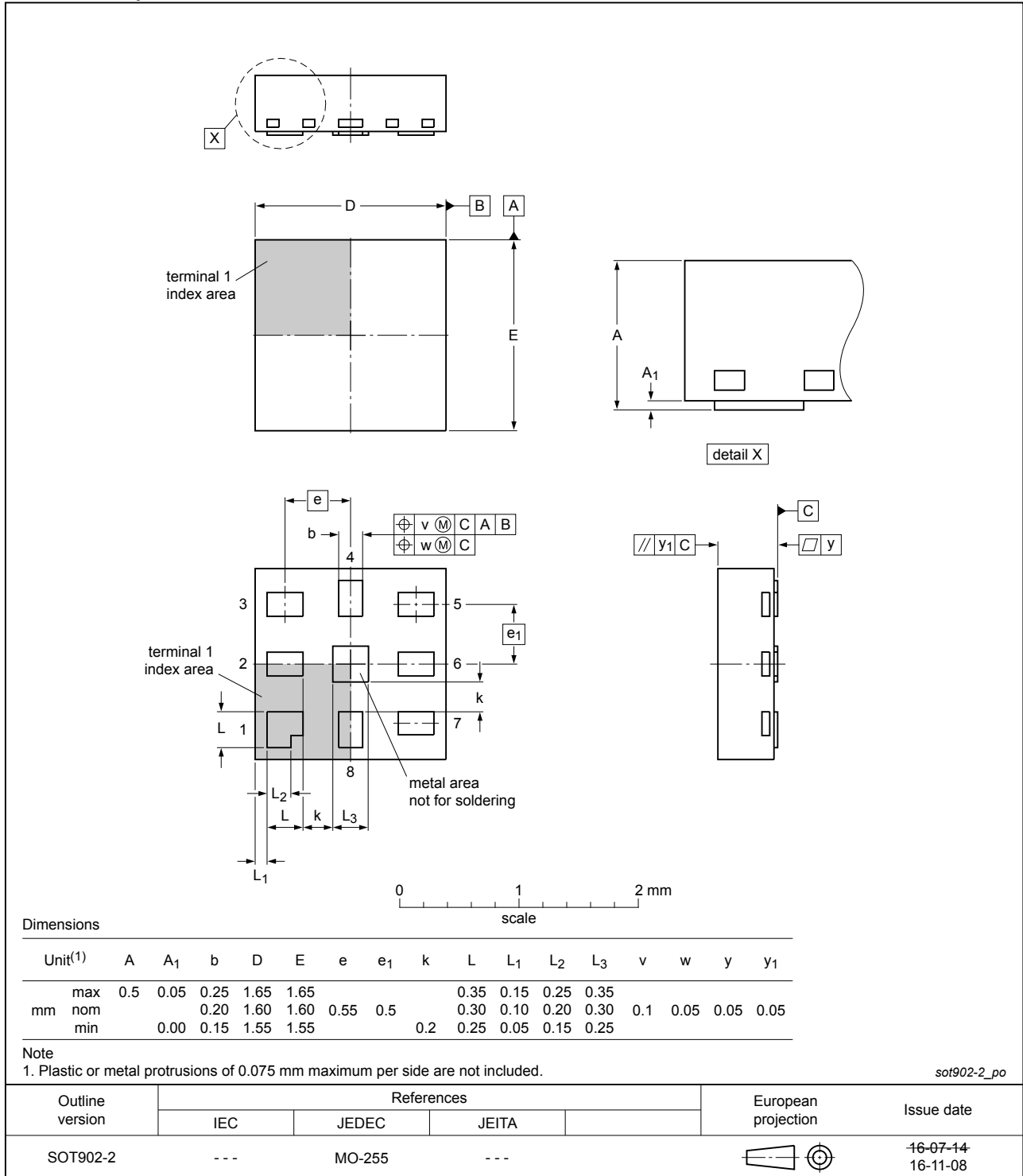

Fig. 28. Package outline SOT902-2 (XQFN8)

XSON8: extremely thin small outline package; no leads;
8 terminals; body 1.2 x 1.0 x 0.35 mm

SOT1116

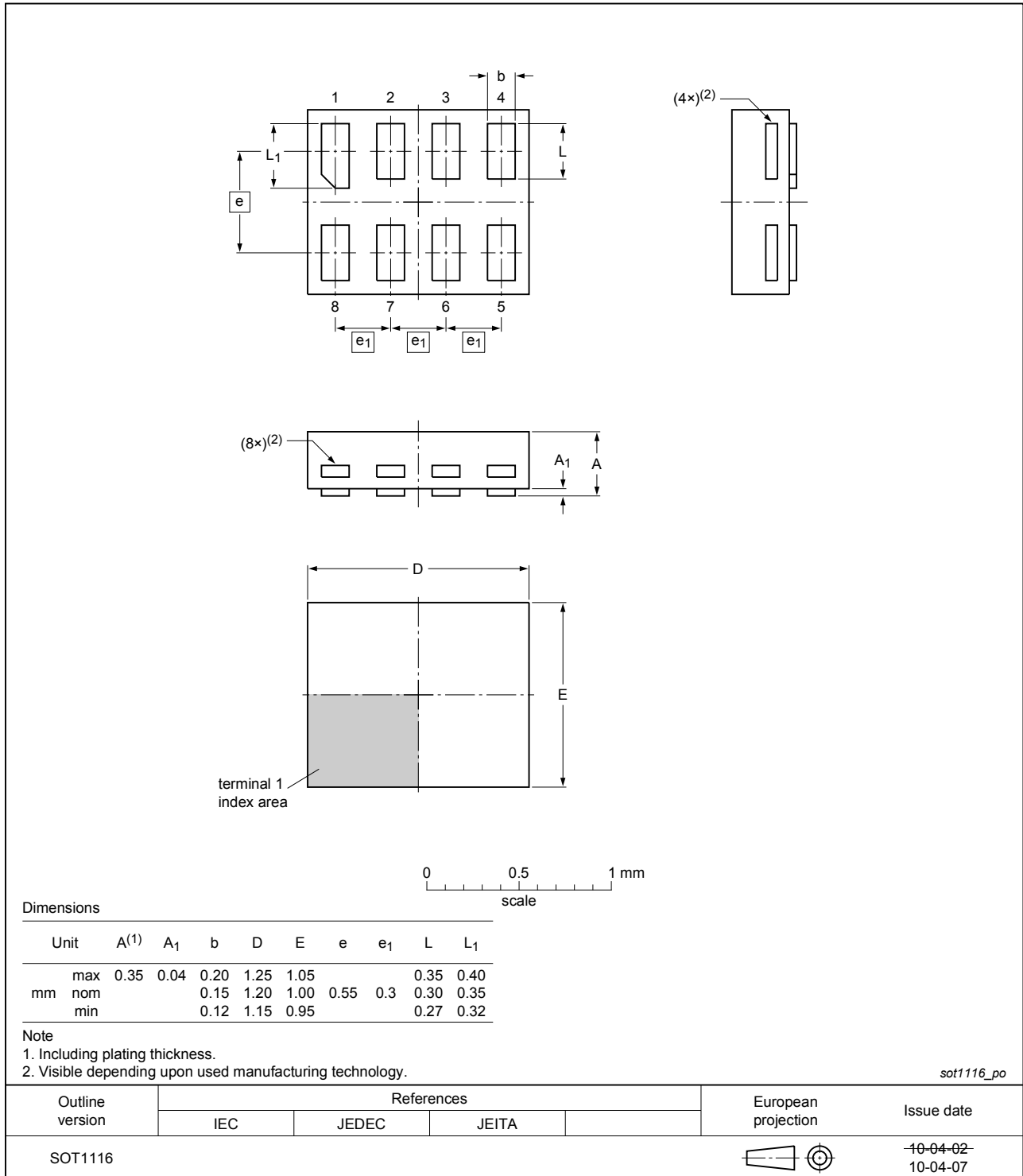

Fig. 29. Package outline SOT1116 (XSON8)

13. Abbreviations

Table 13. Abbreviations

Acronym	Description
CMOS	Complementary Metal-Oxide Semiconductor
DUT	Device Under Test
ESD	ElectroStatic Discharge
HBM	Human Body Model
MM	Machine Model
TTL	Transistor-Transistor Logic

14. Revision history

Table 14. Revision history

Document ID	Release date	Data sheet status	Change notice	Supersedes
74LVC2G66 v.11	20181030	Product data sheet	-	74LVC2G66 v.10
Modifications:	<ul style="list-style-type: none"> Type number 74LVC2G66GD (XSON8/SOT996-2) removed. 			
74LVC2G66 v.10	20170413	Product data sheet	-	74LVC2G66 v.9
Modifications:	<ul style="list-style-type: none"> The format of this data sheet has been redesigned to comply with the new identity guidelines of Nexperia. Legal texts have been adapted to the new company name where appropriate. Type number 74LVC2G66GN (XSON8/SOT1116) has been added. 			
74LVC2G66 v.9	20161215	Product data sheet	-	74LVC2G66 v.8
Modifications:	<ul style="list-style-type: none"> Table 7: The maximum limits for leakage current and supply current have changed. 			
74LVC2G66 v.8	20130402	Product data sheet	-	74LVC2G66 v.7
Modifications:	<ul style="list-style-type: none"> For type number 74LVC2G66GD XSON8U has changed to XSON8. 			
74LVC2G66 v.7	20120622	Product data sheet	-	74LVC2G66 v.6
Modifications:	<ul style="list-style-type: none"> For type number 74LVC2G66GM the SOT code has changed to SOT902-2. 			
74LVC2G66 v.6	20111129	Product data sheet	-	74LVC2G66 v.5
Modifications:	<ul style="list-style-type: none"> Legal pages updated. 			
74LVC2G66 v.5	20100616	Product data sheet	-	74LVC2G66 v.4
74LVC2G66 v.4	20080701	Product data sheet	-	74LVC2G66 v.3
74LVC2G66 v.3	20080310	Product data sheet	-	74LVC2G66 v.2
74LVC2G66 v.2	20070828	Product data sheet	-	74LVC2G66 v.1
74LVC2G66 v.1	20040629	Product data sheet	-	-

15. Legal information

Data sheet status

Document status [1][2]	Product status [3]	Definition
Objective [short] data sheet	Development	This document contains data from the objective specification for product development.
Preliminary [short] data sheet	Qualification	This document contains data from the preliminary specification.
Product [short] data sheet	Production	This document contains the product specification.

- [1] Please consult the most recently issued document before initiating or completing a design.
- [2] The term 'short data sheet' is explained in section "Definitions".
- [3] The product status of device(s) described in this document may have changed since this document was published and may differ in case of multiple devices. The latest product status information is available on the internet at <https://www.nexperia.com>.

Definitions

Draft — The document is a draft version only. The content is still under internal review and subject to formal approval, which may result in modifications or additions. Nexperia does not give any representations or warranties as to the accuracy or completeness of information included herein and shall have no liability for the consequences of use of such information.

Short data sheet — A short data sheet is an extract from a full data sheet with the same product type number(s) and title. A short data sheet is intended for quick reference only and should not be relied upon to contain detailed and full information. For detailed and full information see the relevant full data sheet, which is available on request via the local Nexperia sales office. In case of any inconsistency or conflict with the short data sheet, the full data sheet shall prevail.

Product specification — The information and data provided in a Product data sheet shall define the specification of the product as agreed between Nexperia and its customer, unless Nexperia and customer have explicitly agreed otherwise in writing. In no event however, shall an agreement be valid in which the Nexperia product is deemed to offer functions and qualities beyond those described in the Product data sheet.

Disclaimers

Limited warranty and liability — Information in this document is believed to be accurate and reliable. However, Nexperia does not give any representations or warranties, expressed or implied, as to the accuracy or completeness of such information and shall have no liability for the consequences of use of such information. Nexperia takes no responsibility for the content in this document if provided by an information source outside of Nexperia.

In no event shall Nexperia be liable for any indirect, incidental, punitive, special or consequential damages (including - without limitation - lost profits, lost savings, business interruption, costs related to the removal or replacement of any products or rework charges) whether or not such damages are based on tort (including negligence), warranty, breach of contract or any other legal theory.

Notwithstanding any damages that customer might incur for any reason whatsoever, Nexperia's aggregate and cumulative liability towards customer for the products described herein shall be limited in accordance with the Terms and conditions of commercial sale of Nexperia.

Right to make changes — Nexperia reserves the right to make changes to information published in this document, including without limitation specifications and product descriptions, at any time and without notice. This document supersedes and replaces all information supplied prior to the publication hereof.

Suitability for use — Nexperia products are not designed, authorized or warranted to be suitable for use in life support, life-critical or safety-critical systems or equipment, nor in applications where failure or malfunction of an Nexperia product can reasonably be expected to result in personal

injury, death or severe property or environmental damage. Nexperia and its suppliers accept no liability for inclusion and/or use of Nexperia products in such equipment or applications and therefore such inclusion and/or use is at the customer's own risk.

Quick reference data — The Quick reference data is an extract of the product data given in the Limiting values and Characteristics sections of this document, and as such is not complete, exhaustive or legally binding.

Applications — Applications that are described herein for any of these products are for illustrative purposes only. Nexperia makes no representation or warranty that such applications will be suitable for the specified use without further testing or modification.

Customers are responsible for the design and operation of their applications and products using Nexperia products, and Nexperia accepts no liability for any assistance with applications or customer product design. It is customer's sole responsibility to determine whether the Nexperia product is suitable and fit for the customer's applications and products planned, as well as for the planned application and use of customer's third party customer(s). Customers should provide appropriate design and operating safeguards to minimize the risks associated with their applications and products.

Nexperia does not accept any liability related to any default, damage, costs or problem which is based on any weakness or default in the customer's applications or products, or the application or use by customer's third party customer(s). Customer is responsible for doing all necessary testing for the customer's applications and products using Nexperia products in order to avoid a default of the applications and the products or of the application or use by customer's third party customer(s). Nexperia does not accept any liability in this respect.

Limiting values — Stress above one or more limiting values (as defined in the Absolute Maximum Ratings System of IEC 60134) will cause permanent damage to the device. Limiting values are stress ratings only and (proper) operation of the device at these or any other conditions above those given in the Recommended operating conditions section (if present) or the Characteristics sections of this document is not warranted. Constant or repeated exposure to limiting values will permanently and irreversibly affect the quality and reliability of the device.

Terms and conditions of commercial sale — Nexperia products are sold subject to the general terms and conditions of commercial sale, as published at <http://www.nexperia.com/profile/terms>, unless otherwise agreed in a valid written individual agreement. In case an individual agreement is concluded only the terms and conditions of the respective agreement shall apply. Nexperia hereby expressly objects to applying the customer's general terms and conditions with regard to the purchase of Nexperia products by customer.

No offer to sell or license — Nothing in this document may be interpreted or construed as an offer to sell products that is open for acceptance or the grant, conveyance or implication of any license under any copyrights, patents or other industrial or intellectual property rights.

Export control — This document as well as the item(s) described herein may be subject to export control regulations. Export might require a prior authorization from competent authorities.

Non-automotive qualified products — Unless this data sheet expressly states that this specific Nexperia product is automotive qualified, the product is not suitable for automotive use. It is neither qualified nor tested in accordance with automotive testing or application requirements. Nexperia accepts no liability for inclusion and/or use of non-automotive qualified products in automotive equipment or applications.

In the event that customer uses the product for design-in and use in automotive applications to automotive specifications and standards, customer (a) shall use the product without Nexperia's warranty of the product for such automotive applications, use and specifications, and (b) whenever customer uses the product for automotive applications beyond Nexperia's specifications such use shall be solely at customer's own risk, and (c) customer fully indemnifies Nexperia for any liability, damages or failed product claims resulting from customer design and use of the product for automotive applications beyond Nexperia's standard warranty and Nexperia's product specifications.

Translations — A non-English (translated) version of a document is for reference only. The English version shall prevail in case of any discrepancy between the translated and English versions.

Trademarks

Notice: All referenced brands, product names, service names and trademarks are the property of their respective owners.

Contents

1. General description	1
2. Features and benefits	1
3. Ordering information	1
4. Marking	2
5. Functional diagram	2
6. Pinning information	3
6.1. Pinning.....	3
6.2. Pin description.....	3
7. Functional description	3
8. Limiting values	4
9. Recommended operating conditions	4
10. Static characteristics	5
10.1. Test circuits.....	5
10.2. ON resistance.....	6
10.3. ON resistance test circuit and graphs.....	7
11. Dynamic characteristics	9
11.1. Waveforms and test circuit.....	10
11.2. Additional dynamic characteristics.....	12
11.3. Test circuits.....	13
12. Package outline	16
13. Abbreviations	21
14. Revision history	21
15. Legal information	22

© Nexperia B.V. 2018. All rights reserved



For more information, please visit: <http://www.nexperia.com>

For sales office addresses, please send an email to: salesaddresses@nexperia.com

Date of release: 30 October 2018

Looking for pricing, stock, or lifecycle information?

Click below to explore more details on WIN SOURCE:

-  [View 74LVC2G66DC,125 on WIN SOURCE](#)
-  [NXP / Nexperia Information](#)

Optimize Your Supply Chain with WIN SOURCE Solutions

-  Global Sourcing Solution
-  Obsolete Management
-  Cost Control Management
-  Shortage Management
-  Alternative Solution
-  Excess Inventory Management