



THE DATASHEET OF STP16DP05MTR



Low voltage 16-bit constant current LED sink driver with outputs error detection

Datasheet - production data

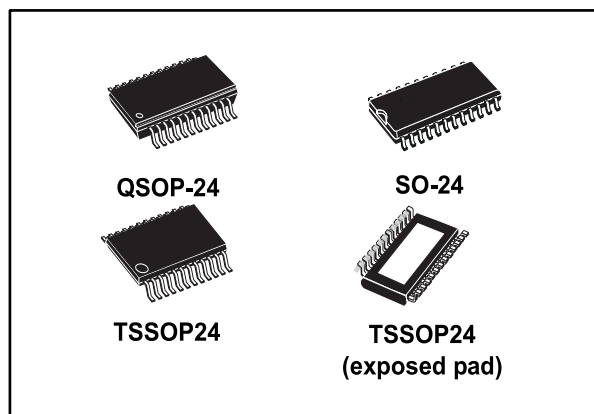

LED panel displays. The device contains a 16-bit serial-in, parallel-out shift register that feeds a 16-bit D-type storage register. In the output stage, sixteen regulated current sources were designed to provide 5-100 mA constant current to drive the LEDs. The STP16DP05 features open and short LED detections on the outputs. The STP16DP05 is backward compatible with STP16C/L596. The detection circuit checks 3 different conditions that can occur on the output line: short to GND, short to V_O or open line. The data detection results are loaded in the shift register and shifted out via the serial line output. The detection functionality is implemented without increasing the pin count number, through a secondary function of the output enable and latch pin (DM1 and DM2 respectively), a dedicated logic sequence allows the device to enter or leave from detection mode. Through an external resistor, users can adjust the STP16DP05 output current, controlling in this way the light intensity of LEDs, in addition, user can adjust LED's brightness intensity from 0 % to 100 % via $\overline{OE/DM2}$ pin. The STP16DP05 guarantees a 20 V output driving capability, allowing users to connect more LEDs in series. The high clock frequency, 30 MHz, makes the device suitable for high data rate transmission. The 3.3 V voltage supply is well useful for applications that interface any 3.3 V micro. Compared with a standard TSSOP package, the TSSOP exposed pad increases heat dissipation capability by a 2.5 factor.

Features

- Low voltage power supply down to 3 V
- 16 constant current output channels
- Adjustable output current through external resistor
- Short and open output error detection
- Serial data IN/Parallel data OUT
- 3.3 V micro driver-able
- Output current: 5-100 mA
- 30 MHz clock frequency
- Available in high thermal efficiency TSSOP exposed pad
- ESD protection 2.5 kV HBM, 200 V MM

Description

The STP16DP05 is a monolithic, low voltage, low current power 16-bit shift register designed for

Table 1: Device summary

Order code	Package	Packing
STP16DP05MTR	SO-24 (tape and reel)	1000 parts per reel
STP16DP05TTR	TSSOP24 (tape and reel)	2500 parts per reel
STP16DP05XTTR	TSSOP24 exposed pad (tape and reel)	2500 parts per reel
STP16DP05PTR	QSOP-24	2500 parts per reel

Contents

1 Summary description..... 3

 1.1 Pin connection and description 3

2 Electrical ratings 4

 2.1 Absolute maximum ratings 4

 2.2 Thermal data 4

 2.3 Recommended operating conditions 5

3 Electrical characteristics 6

4 Equivalent circuit and outputs 8

5 Timing diagrams..... 11

6 Typical characteristics 14

7 Detection mode functionality 17

 7.1 Phase one: “entering in detection mode“ 17

 7.2 Phase two: “error detection” 18

 7.3 Phase three: “resuming to normal mode” 20

 7.4 Error detection conditions 20

8 Package information 23

 8.1 QSOP-24 package information 24

 8.2 SO-24 package information 26

 8.3 TSSOP24 package information 27

 8.4 TSSOP24 exposed pad package information 29

 8.5 TSSOP24, TSSOP24 exposed pad and SO-24 packing information 31

9 Revision history 33



1 Summary description

Table 2: Typical current accuracy

Output voltage	Current accuracy		Output current	V _{DD}	Temperature
	Between bits	Between ICs			
≥ 1.3 V	±1.5 %	±5 %	20 to 100 mA	3.3 V to 5 V	25 °C

1.1 Pin connection and description

Figure 1: Pin connection

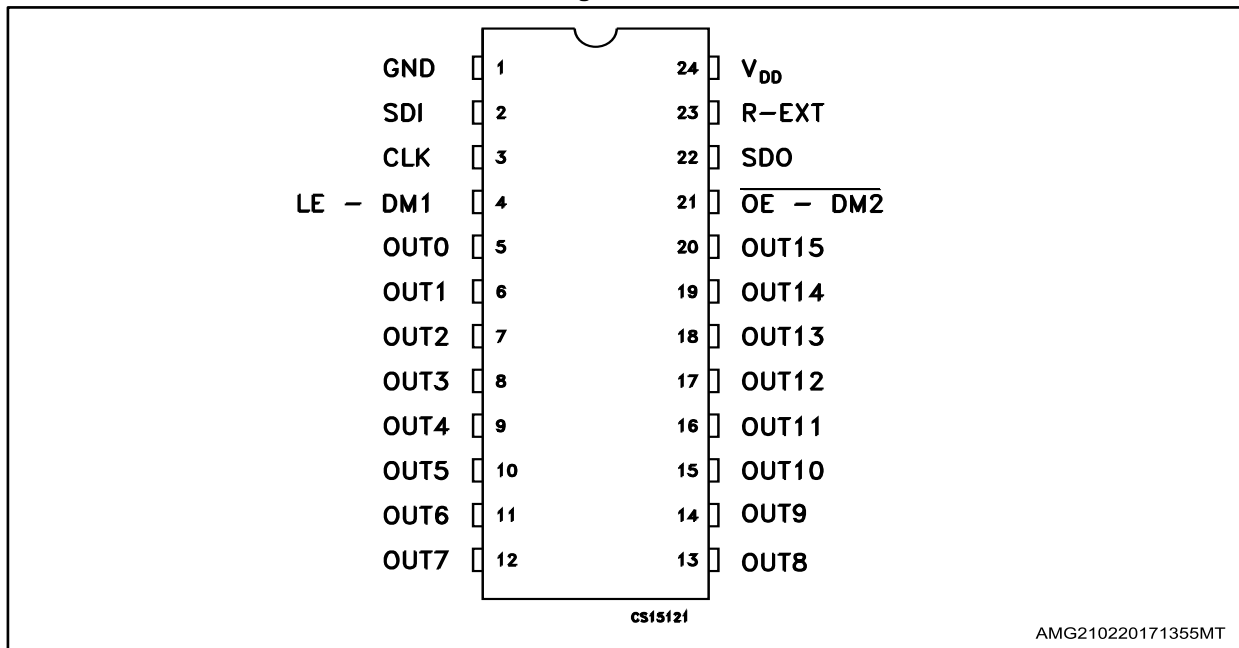

The exposed pad should be electrically connected to a metal land electrically isolated or connected to ground

Table 3: Pin description

Pin n°	Symbol	Name and function
1	GND	Ground terminal
2	SDI	Serial data input terminal
3	CLK	Clock input terminal
4	LE-DM1	Latch input terminal - detect mode 1 (see operation principle)
5-20	OUT 0-15	Output terminal
21	OE-DM2	Input terminal of output enable (active low) - detect mode 1 (see operation principle)
22	SDO	Serial data out terminal
23	R-EXT	Input terminal of an external resistor for constant current programming
24	V _{DD}	Supply voltage terminal

2 Electrical ratings

2.1 Absolute maximum ratings

Stressing the device above the rating listed in the “absolute maximum ratings” table may cause permanent damage to the device. These are stress ratings only and operation of the device at these or any other conditions above those indicated in the operating sections of this specification is not implied. Exposure to absolute maximum rating conditions for extended periods may affect device reliability.

Table 4: Absolute maximum ratings

Symbol	Parameter	Value	Unit
V _{DD}	Supply voltage	0 to 7	V
V _O	Output voltage	-0.5 to 20	V
I _O	Output current	100	mA
V _I	Input voltage	-0.4 to V _{DD}	V
I _{GND}	GND terminal current	1600	mA
f _{CLK}	Clock frequency	50	MHz

2.2 Thermal data

Table 5: Thermal data

Symbol	Parameter	Value	Unit
T _{OPR}	Operating temperature range	-40 to +125	°C
T _{STG}	Storage temperature range	-55 to +150	°C
R _{thJA}	Thermal resistance junction-ambient	SO-24	42.7 °C/W
		TSSOP24	55 °C/W
		TSSOP24 exposed pad ⁽¹⁾	37.5 °C/W
		QSOP-24	55 °C/W

Notes:

⁽¹⁾The exposed pad should be soldered directly to the PCB to realize the thermal benefits.

2.4 Recommended operating conditions

Table 6: Recommended operating conditions

Symbol	Parameter	Test condition	Min.	Typ.	Max.	Unit
V _{DD}	Supply voltage		3.0	-	5.5	V
V _O	Output voltage			-	20	V
I _O	Output current	OUT _n	5	-	100	mA
I _{OH}	Output current	SERIAL-OUT		-	+1	mA
I _{OL}	Output current	SERIAL-OUT		-	-1	mA
V _{IH}	Input voltage		0.7 V _{DD}	-	V _{DD} +0.3	V
V _{IL}	Input voltage		-0.3	-	0.3 V _{DD}	V
t _{wLAT}	LE\DM1 pulse width	V _{DD} = 3.0 V to 5.0 V	6	-		ns
t _{wCLK}	CLK pulse width		8	-		ns
t _{wEN}	$\overline{\text{OE/DM2}}$ pulse width		100	-		ns
t _{SETUP(D)}	Setup time for DATA		10	-		ns
t _{HOLD(D)}	Hold time for DATA		5	-		ns
t _{SETUP(L)}	Setup time for LATCH		10	-		ns
f _{CLK}	Clock frequency		Cascade operation ⁽¹⁾		-	30

Notes:

⁽¹⁾If the device is connected in cascade, it may not be possible to achieve the maximum data transfer. Please consider the timings carefully.

3 Electrical characteristics

$V_{DD} = 3.3\text{ V to }5\text{ V}$, $T = 25\text{ }^{\circ}\text{C}$, unless otherwise specified

Table 7: Electrical characteristics

Symbol	Parameter	Test conditions	Min.	Typ.	Max.	Unit
V_{IH}	Input voltage high level		$0.7 V_{DD}$		V_{DD}	V
V_{IL}	Input voltage low level		GND		$0.3 V_{DD}$	V
I_{OH}	Output leakage current	$V_{OH} = 20\text{ V}$			1	μA
V_{OL}	Output voltage (serial-OUT)	$I_{OL} = 1\text{ mA}$			0.4	V
V_{OH}	Output voltage (serial-OUT)	$I_{OH} = -1\text{ mA}$	$V_{OH} - V_{DD} = -0.4\text{ V}$			V
I_{OL1}	Output current	$V_O = 0.3\text{ V}$ $R_{EXT} = 3.9\text{ k}\Omega$	4.25	5	5.75	mA
I_{OL2}		$V_O = 0.3\text{ V}$ $R_{EXT} = 970\ \Omega$	19	20	21	
I_{OL3}		$V_O = 1.3\text{ V}$ $R_{EXT} = 190\ \Omega$	96	100	104	
ΔI_{OL1}	Output current error between bit (all output ON)	$V_O = 0.3\text{ V}$ $R_{EXT} = 3.9\text{ k}\Omega$		± 5	± 8	%
ΔI_{OL2}		$V_O = 0.3\text{ V}$ $R_{EXT} = 970\ \Omega$		± 1.5	± 3	
ΔI_{OL3}		$V_O = 1.3\text{ V}$ $R_{EXT} = 190\ \Omega$		± 1.2	± 3	
$R_{SIN(up)}$	Pull-up resistor		150	300	600	$\text{k}\Omega$
$R_{SIN(down)}$	Pull-down resistor		100	200	400	$\text{k}\Omega$
$I_{DD(OFF1)}$	Supply current (OFF)	$R_{EXT} = 970\ \Omega$ OUT 0 to 15 = OFF		5	6	mA
$I_{DD(OFF2)}$		$R_{EXT} = 240\ \Omega$ OUT 0 to 15 = OFF		13	14	
$I_{DD(ON1)}$	Supply current (ON)	$R_{EXT} = 970\ \Omega$ OUT 0 to 15 = ON		6	7	
$I_{DD(ON2)}$		$R_{EXT} = 240\ \Omega$ OUT 0 to 15 = ON		13.5	14.5	
Thermal	Thermal protection ⁽¹⁾			170		$^{\circ}\text{C}$

Notes:

⁽¹⁾Guaranteed by design (not tested). The thermal protection switches OFF only the outputs current.

V_{DD} = 5 V, T = 25 °C, unless otherwise specified.

Table 8: Switching characteristics

Symbol	Parameter	Test conditions	Min.	Typ.	Max.	Unit	
t _{PLH1}	Propagation delay time, CLK - $\overline{\text{OUTn}}$, LE/DM1 = H, $\overline{\text{OE/DM2}}$ = L	V _{IH} = V _{DD} V _{IL} = GND C _L = 10 pF I _O = 20 mA V _L = 3.0 V R _{EXT} = 1 KΩ R _L = 60 Ω	V _{DD} = 3.3 V	-	40	65	ns
			V _{DD} = 5 V	-	20	30	
t _{PLH2}	Propagation delay time, LE/DM1 - $\overline{\text{OUTn}}$, $\overline{\text{OE/DM2}}$ = L		V _{DD} = 3.3 V	-	51	77	ns
			V _{DD} = 5 V	-	32	47	
t _{PLH3}	Propagation delay time, $\overline{\text{OE/DM2}}$ - $\overline{\text{OUTn}}$, LE/DM1 = H		V _{DD} = 3.3 V	-	49	77	ns
			V _{DD} = 5 V	-	27	41	
t _{PLH}	Propagation delay time, CLK-SDO		V _{DD} = 3.3 V	-	21.5	32	ns
			V _{DD} = 5 V	-	14.5	21.5	
t _{PHL1}	Propagation delay time, CLK - $\overline{\text{OUTn}}$, LE/DM1 = H, $\overline{\text{OE/DM2}}$ = L		V _{DD} = 3.3 V	-	15	25	ns
			V _{DD} = 5 V	-	11	14.5	
t _{PHL2}	Propagation delay time, LE/DM1 - $\overline{\text{OUTn}}$, $\overline{\text{OE/DM2}}$ = L	V _{DD} = 3.3 V	-	13	20	ns	
		V _{DD} = 5 V	-	9	12.5		
t _{PHL3}	Propagation delay time, $\overline{\text{OE/DM2}}$ - $\overline{\text{OUTn}}$, LE/DM1 = H	V _{DD} = 3.3 V	-	11.5	18	ns	
		V _{DD} = 5 V	-	8.5	12		
t _{PHL}	Propagation delay time, CLK-SDO	V _{DD} = 3.3 V	-	25.5	38	ns	
		V _{DD} = 5 V	-	17.5	25		
t _{ON}	Output fall time 10~90 % of voltage waveform	V _{DD} = 3.3 V	-	34	53.5	ns	
		V _{DD} = 5 V	-	12.5	18.5		
t _{OFF}	Output rise time 90~10 % of voltage waveform	V _{DD} = 3.3 V	-	5.5	8.5	ns	
		V _{DD} = 5 V	-	4.5	6.5		
t _r	CLK rise time ⁽¹⁾		-		5000	ns	
t _f	CLK fall time ⁽¹⁾		-		5000	ns	

Notes:

⁽¹⁾In order to achieve high cascade data transfer, please consider tr/tf timings carefully.

4 Equivalent circuit and outputs

Figure 2: OE\DM2 terminal

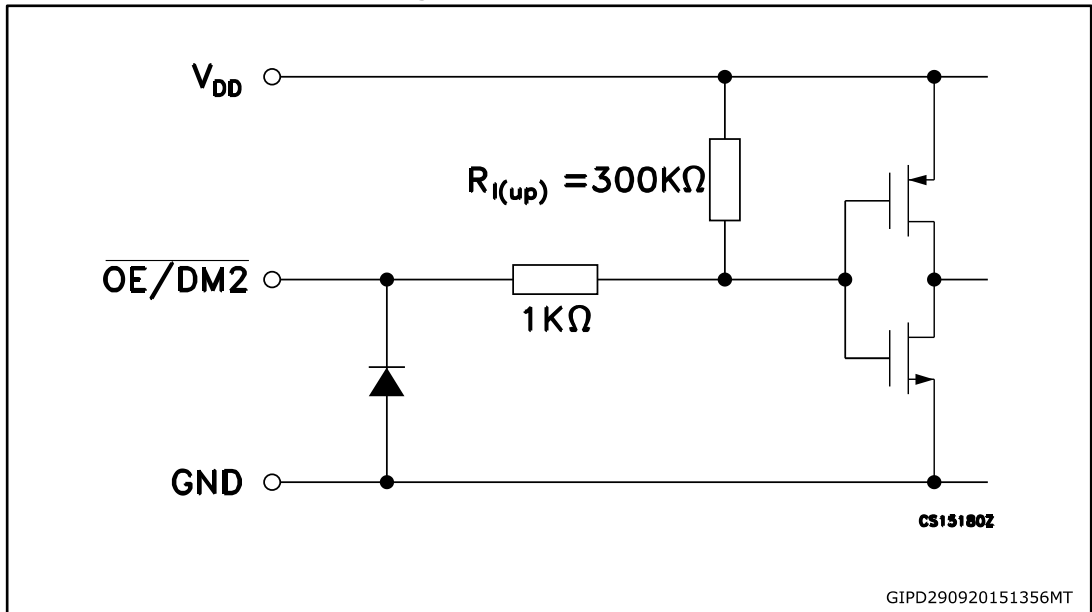

Figure 3: LE\DM1 terminal

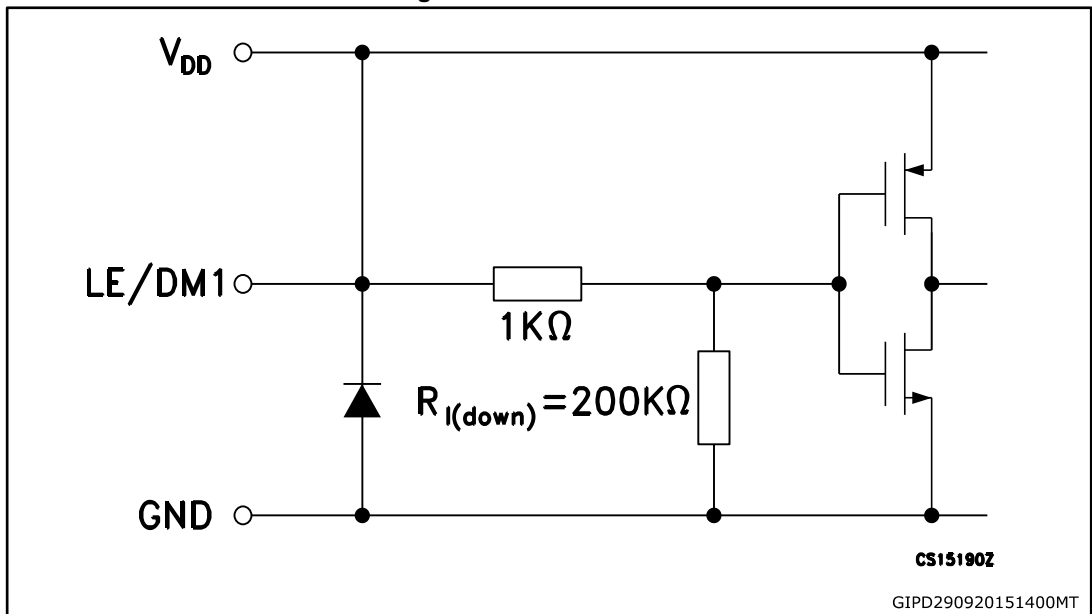

Figure 4: CLK, SDI terminal

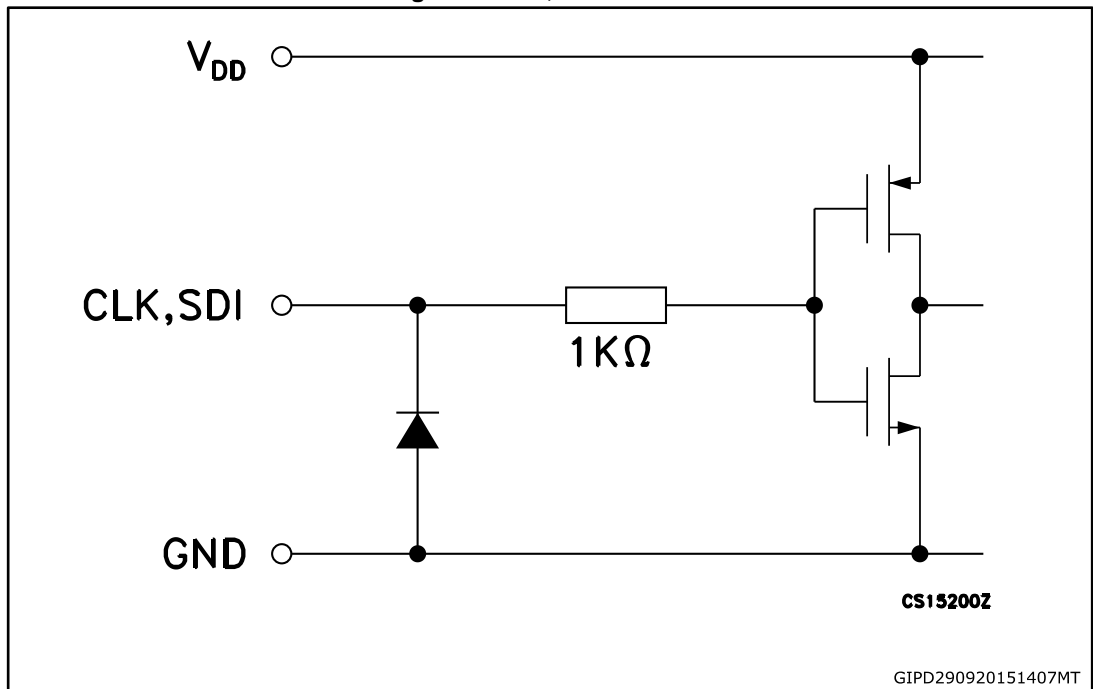

Figure 5: SDO terminal

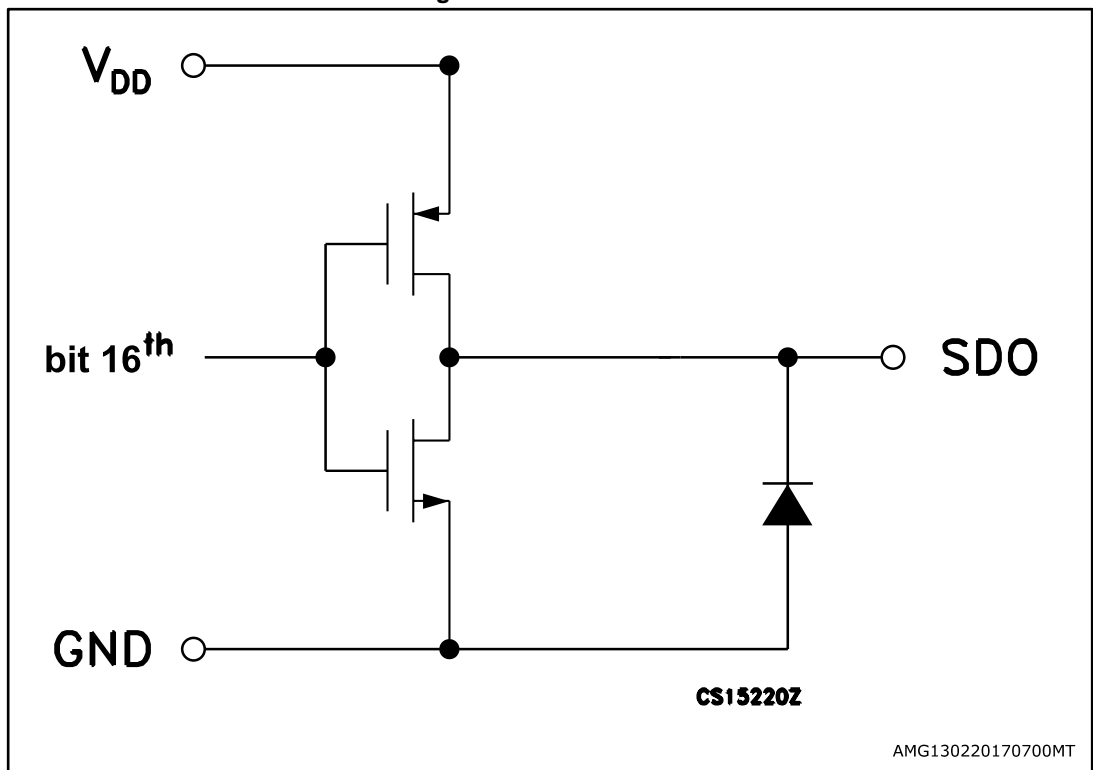
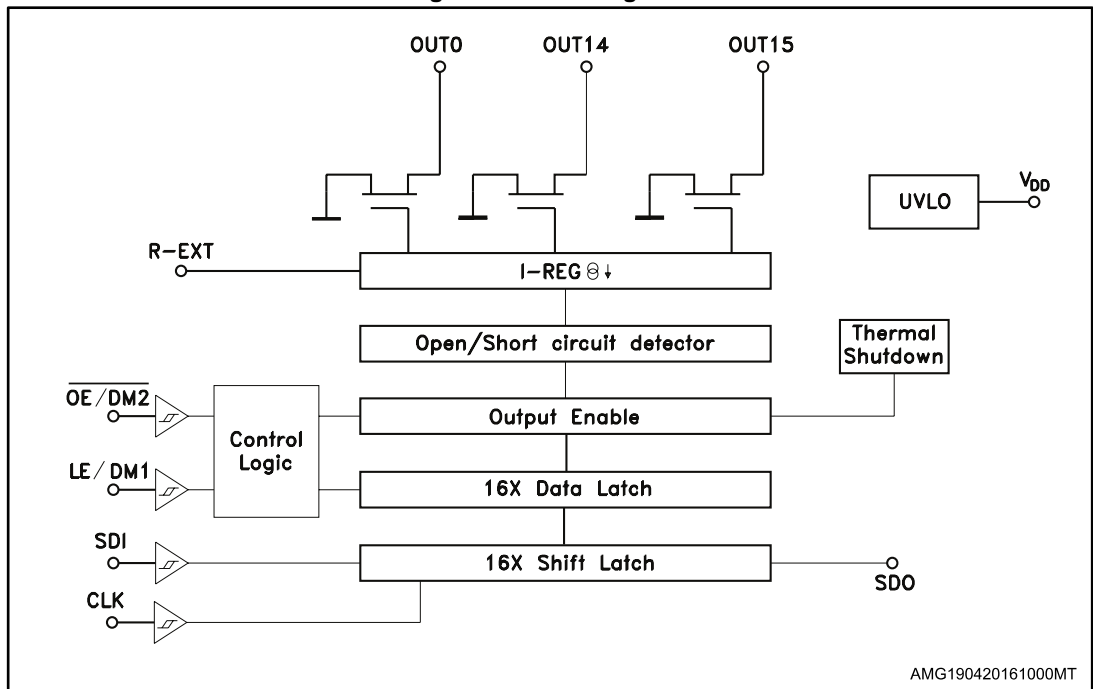

Figure 6: Block diagram



5 Timing diagrams

Table 9: Truth table

CLOCK	LE\DM1	OE/DM2	SERIAL-IN	OUT0OUT7.....OUT15	SDO
	H	L	Dn	Dn Dn - 7 Dn -15	Dn - 15
	L	L	Dn + 1	No change	Dn - 14
	H	L	Dn + 2	Dn + 2 Dn - 5 Dn -13	Dn - 13
	X	L	Dn + 3	Dn + 2 Dn - 5 Dn -13	Dn - 13
	X	H	Dn + 3	OFF	Dn - 13



OUTn = ON when Dn = H OUTn = OFF when Dn = L

Figure 7: Timing diagram

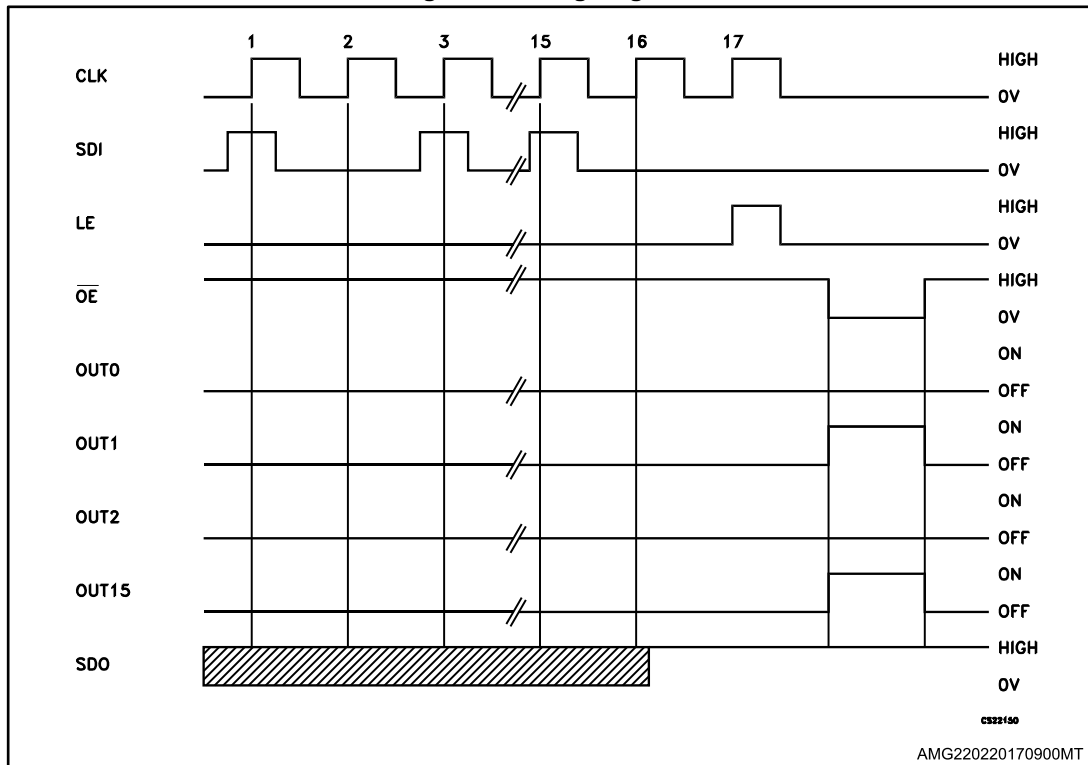

1 - Latch and output enable are level sensitive and ARE NOT synchronized with rising-or-falling edge of CLK signal.

2 - When LE terminal is low level, the latch circuits hold previous set of data.

3 - When LE terminal is at high level, the latch circuits refresh new set of data from SDI chain.

4 - When OE terminal is at low level, the output terminals - Out0 to Out15 respond to data in the latch circuits, either '1' for ON or '0' for OFF.

5 - When OE terminal is at high level, all output terminals will be switched OFF.

Figure 8: Clock, serial-in, serial-out

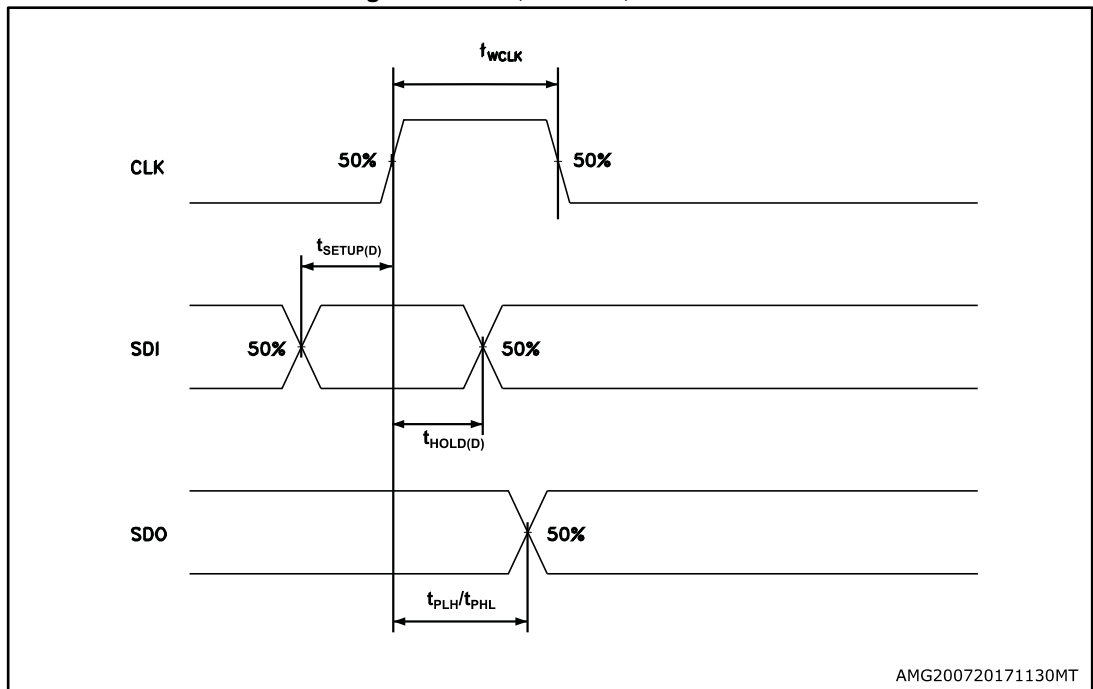

Figure 9: Clock, serial-in, latch, enable, outputs

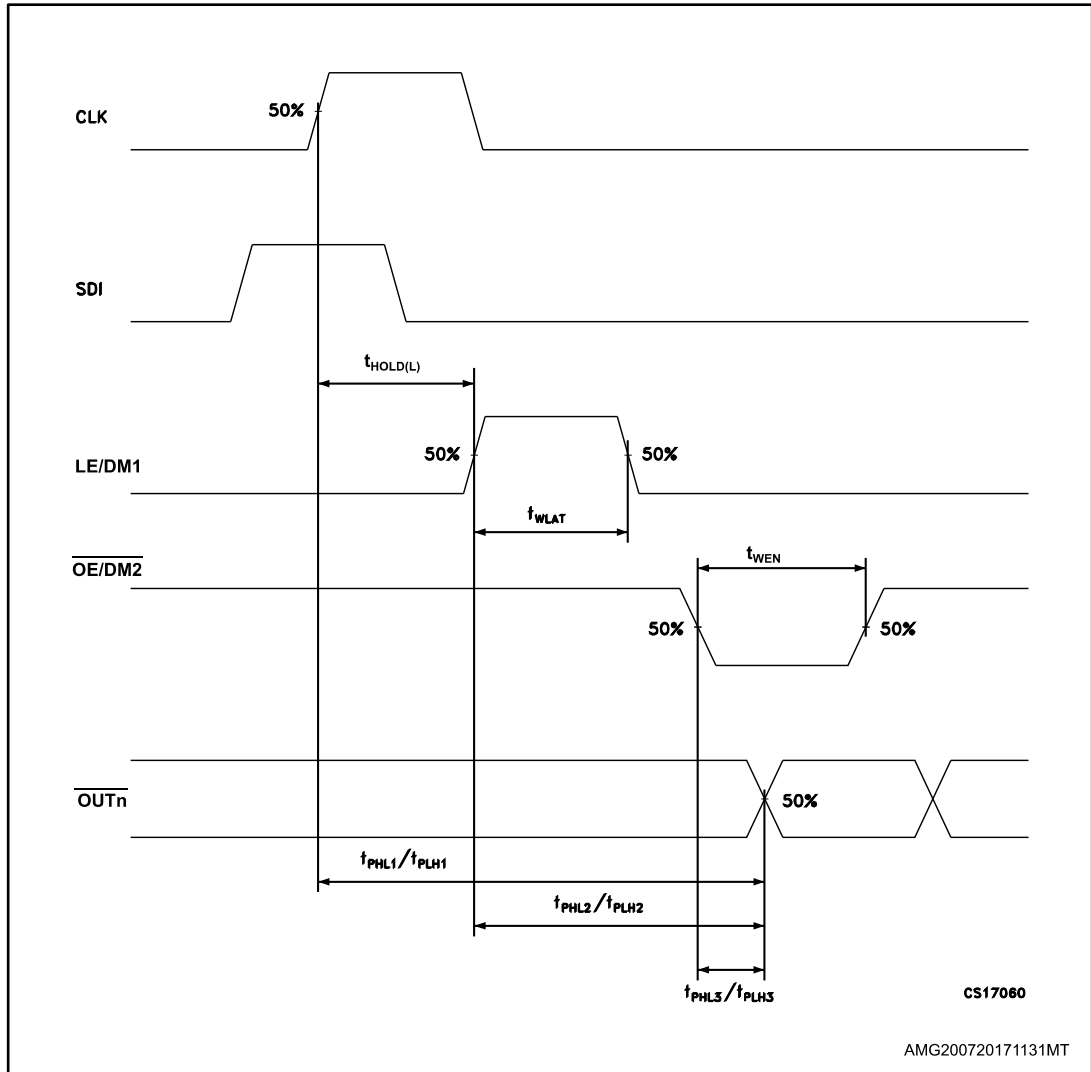
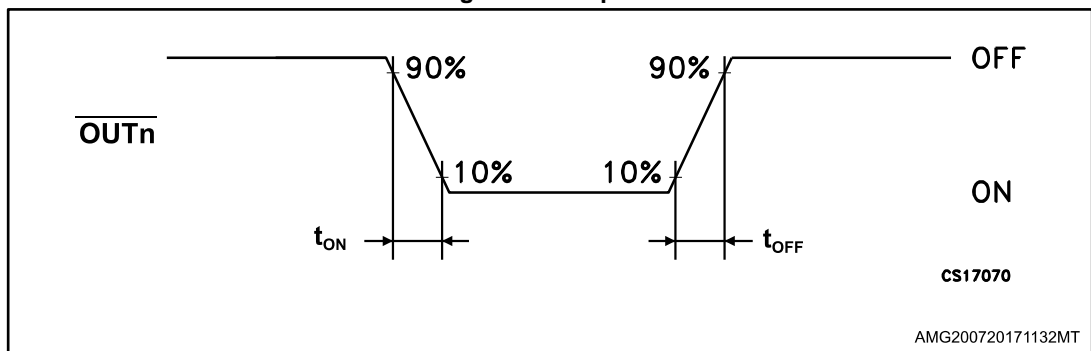

Figure 10: Outputs



6 Typical characteristics

Figure 11: Output current-Rext resistor

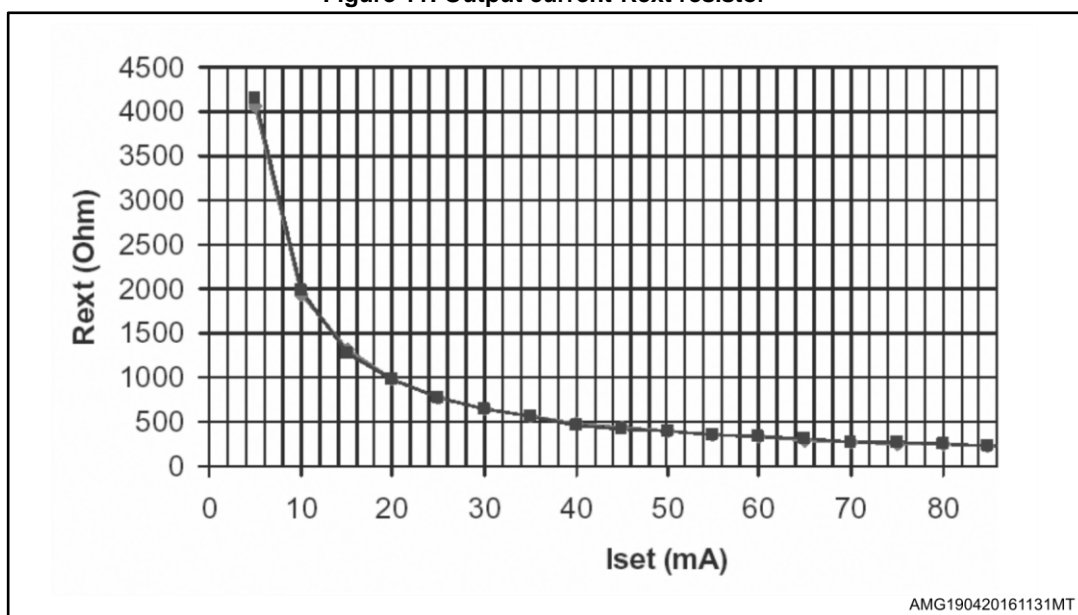

Table 10: Output current-Rext resistor

Rext (Ω)	Output current (mA)
976	20
780	25
652	30
560	35
488	40
433	45
389	50
354	55
325	60
300	65
278	70
259	75
241	80
229	85
215	90

Conditions:

Temperature = 25 °C, V_{DD} = 3.3 V; 5.0 V, I_{SET} = 3 mA; 5 mA; 10 mA; 20 mA; 50 mA; 80 mA.

Figure 12: I_{SET} vs drop out voltage (V_{drop})

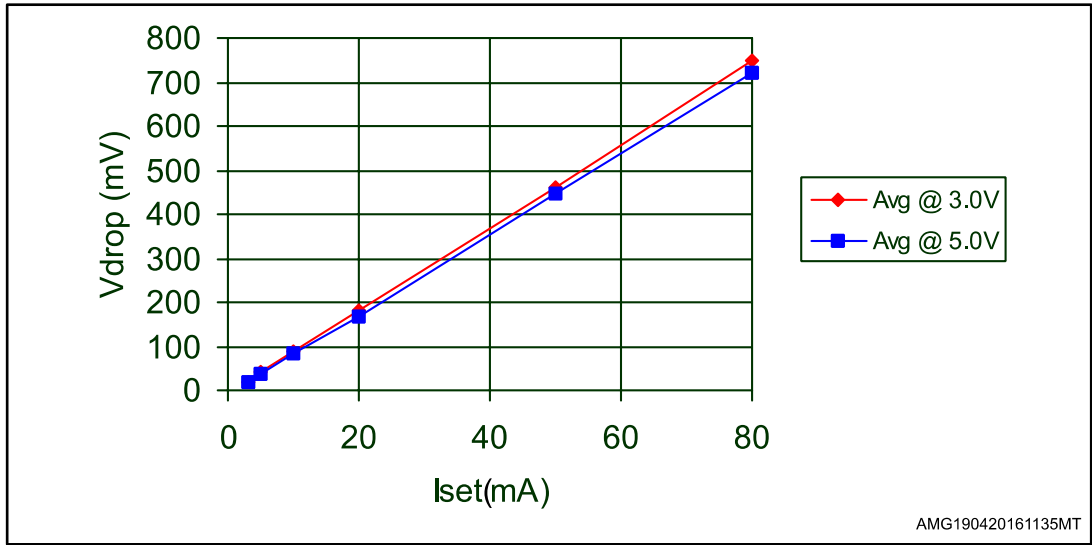

AMG190420161135MT

Table 11: I_{SET} vs drop out voltage (V_{drop})

Iout (mA)	Avg @ 3.0 V	Avg @ 5.0 V
3	19.33	22.66
5	36.67	40.33
10	77.33	80
20	158.67	157.33
50	406	406
80	692	668

Figure 13: I_{DD} ON/OFF

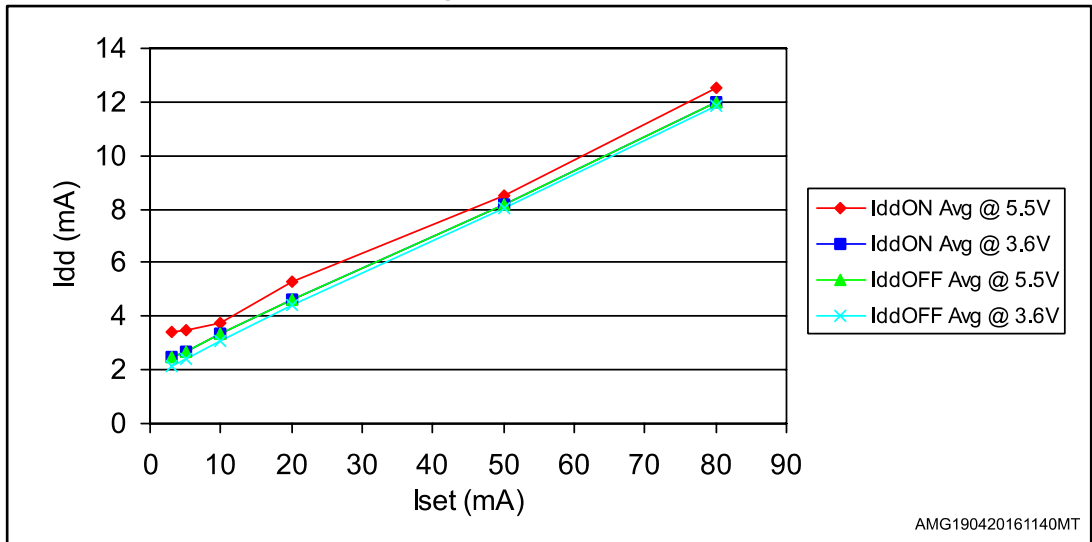

AMG190420161140MT

Figure 14: Power dissipation vs temperature package

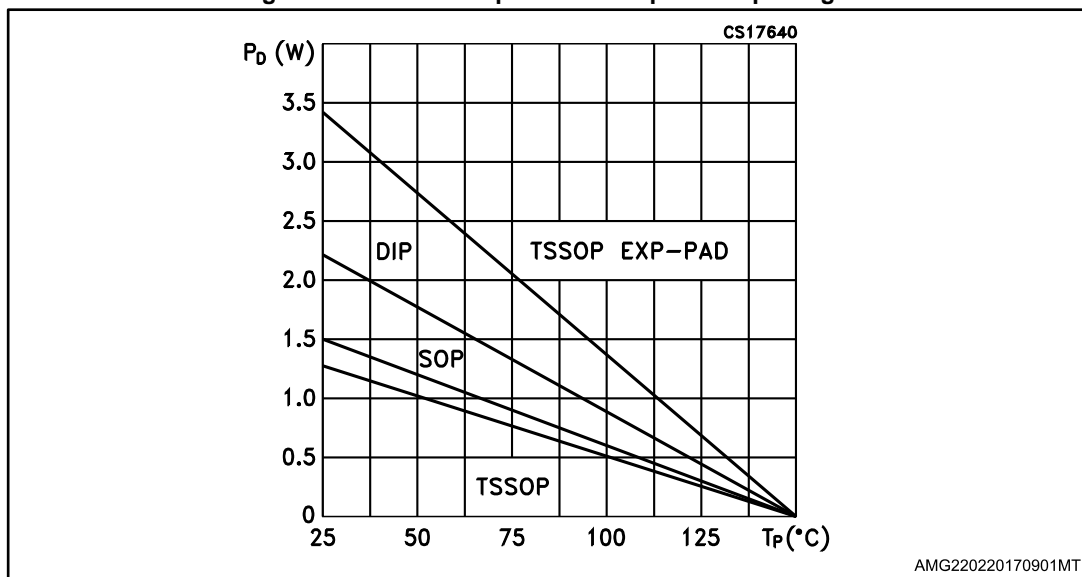

The exposed pad should be soldered to the PBC to realize the thermal benefits.

7 Detection mode functionality

7.1 Phase one: “entering in detection mode“

From the “normal mode” condition the device can switch to the “error mode” by a logic sequence on the $\overline{\text{OE/DM2}}$ and LE/DM1 pins as showed in the following table and diagram:

Table 12: Entering in detection truth table

CLK	1°	2°	3°	4°	5°
$\overline{\text{OE/DM2}}$	H	L	H	H	H
LE/DM1	L	L	L	H	L

Figure 15: Entering in detection timing diagram

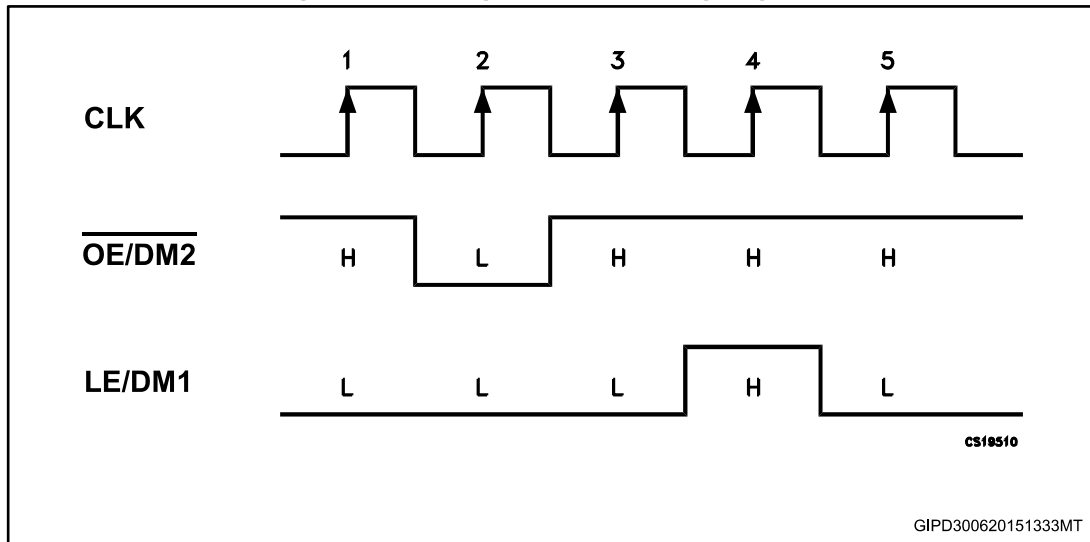

After these five CLK cycles the device goes into the “error detection mode” and at the 6th rise front of CLK the SDI data are ready for the sampling.

7.2 Phase two: “error detection”

The 16 data bits must be set “1” in order to set ON all the outputs during the detection. The data are latched by LE/DM1 and after that the outputs are ready for the detection process. When the micro controller switches the $\overline{\text{OE/DM2}}$ to LOW, the device drives the LEDs in order to analyze if an OPEN or SHORT condition has occurred.

Figure 16: Detection diagram

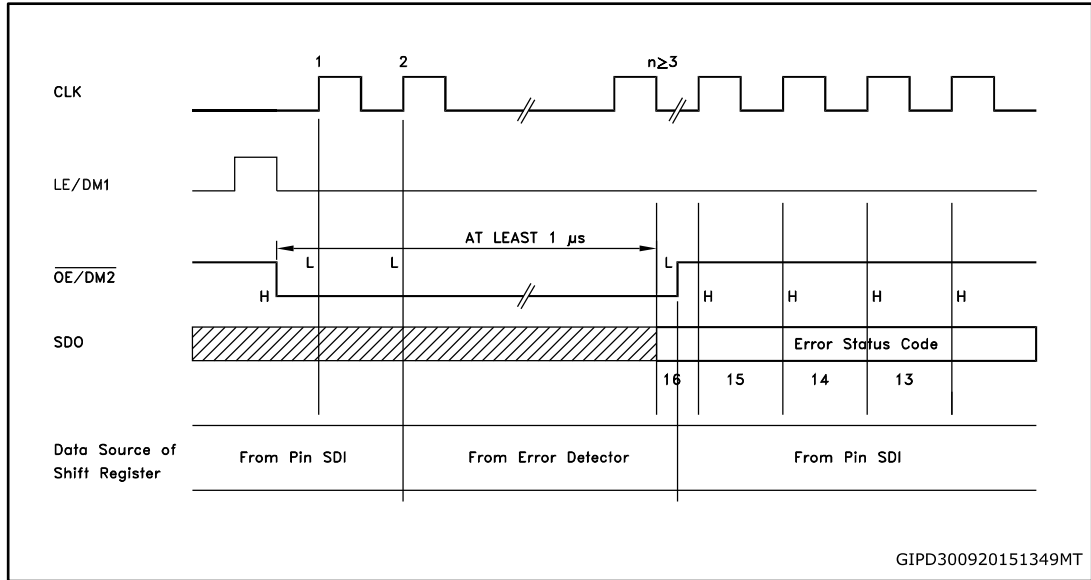

The LEDs status will be detected at least in 1 microsecond and after this time the microcontroller sets $\overline{\text{OE/DM2}}$ in HIGH state and the output data detection result will go to the microprocessor via SDO.

Detection mode and normal mode use both the same format data. As soon as all the detection data bits are available on the serial line, the device may go back to normal mode of operation. To re-detect the status the device must go back in normal mode and re-entering in error detection mode.

Figure 17: Timing example for open and/or short detection

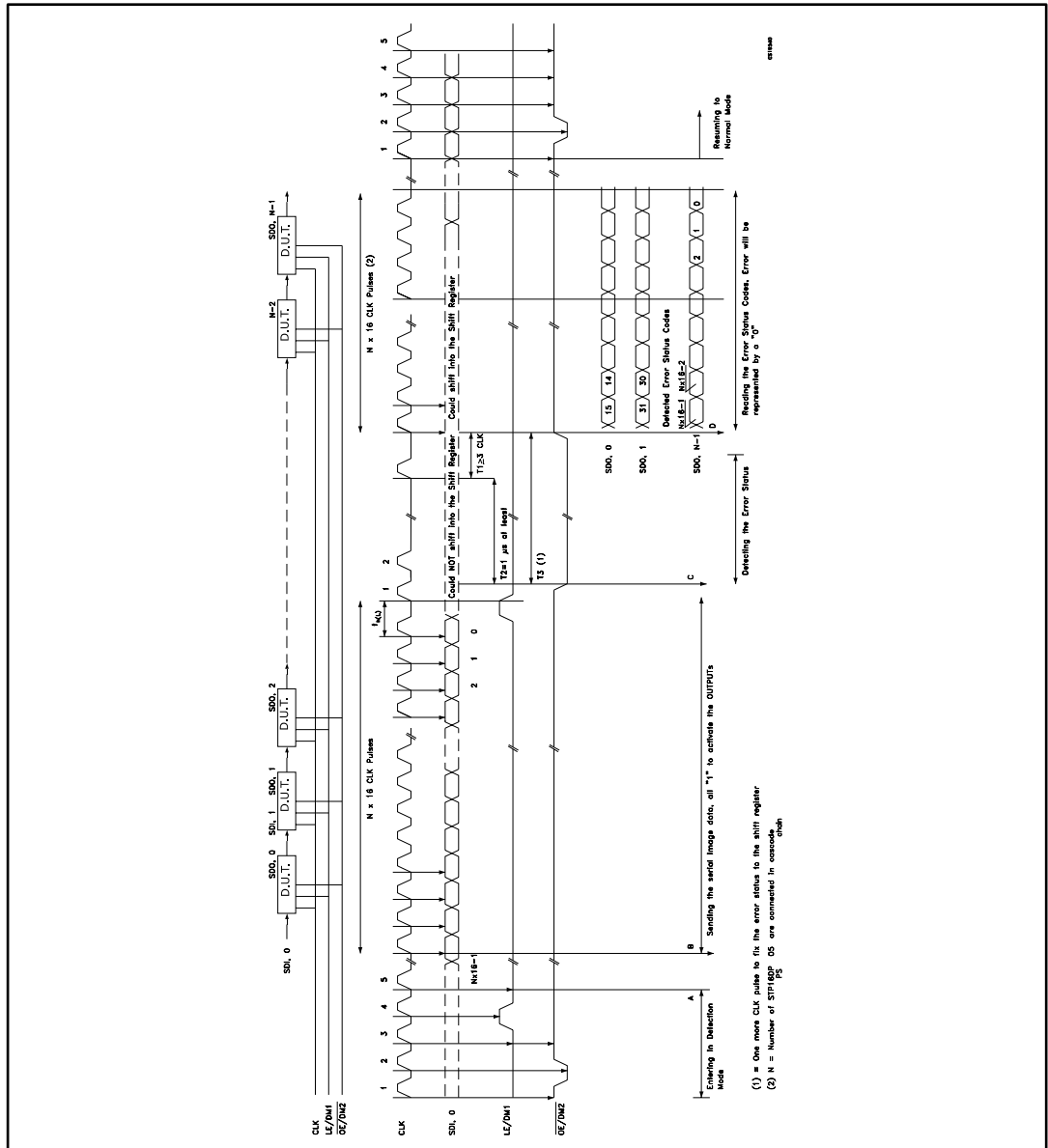

7.3 Phase three: “resuming to normal mode”

The sequence for re-entering in normal mode is showed in the following table and diagram:

Table 13: Resuming to normal mode timing diagram

CLK	1°	2°	3°	4°	5°
$\overline{\text{OE/DM2}}$	H	L	H	H	H
$\overline{\text{LE/DM1}}$	L	L	L	L	L



For proper device operation the “Entering in detection” sequence must be follow by a “resume mode” sequence, it is not possible to insert consecutive equal sequence.

7.4 Error detection conditions

$V_{DD} = 3.3$ to 5 V temperature range -40 to 125 °C

Table 14: Detection conditions

SW-1 or SW-3b	Open line or output short to GND detected	$\implies I_{ODEC} \leq 0.5 \times I_o$	No error detected	$\implies I_{ODEC} \geq 0.5 \times I_o$
SW-2 or SW-3a	Short on LED or short to V-LED detected	$\implies V_o \geq 2.4$ V	No error detected	$\implies V_o \leq 2.2$ V



Where: I_o = the output current programmed by the R_{EXT} , I_{ODEC} = the detected output current in detection mode.

Figure 18: Detection circuit

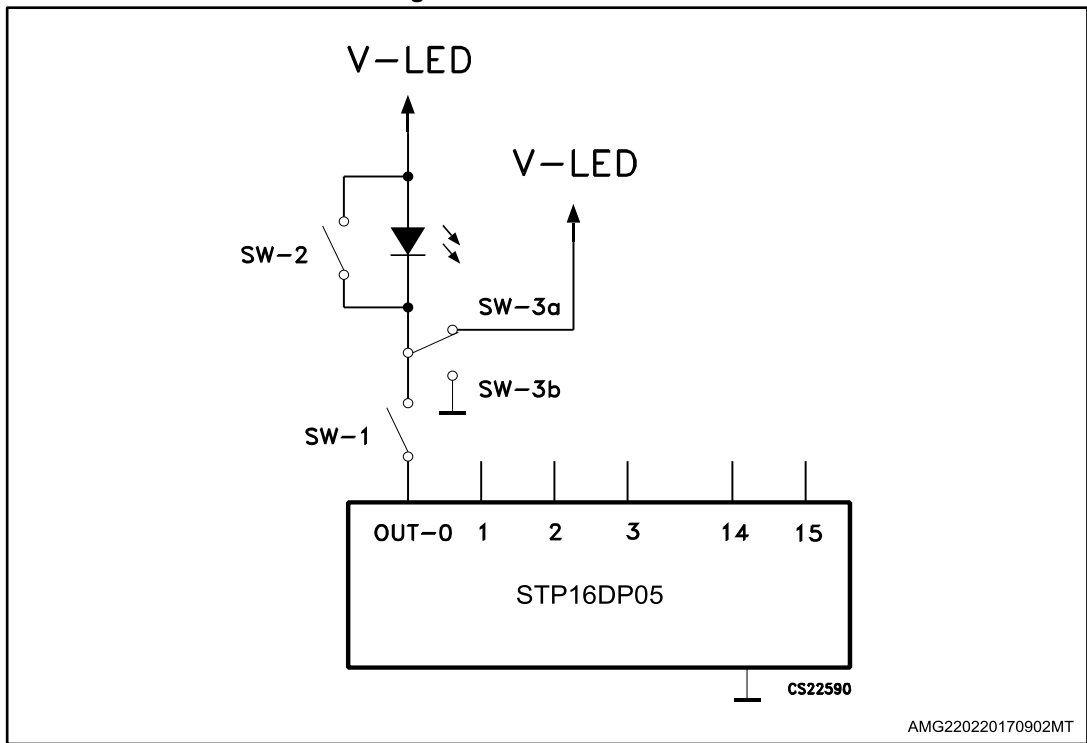

AMG220220170902MT

Figure 19: Error detection sequence

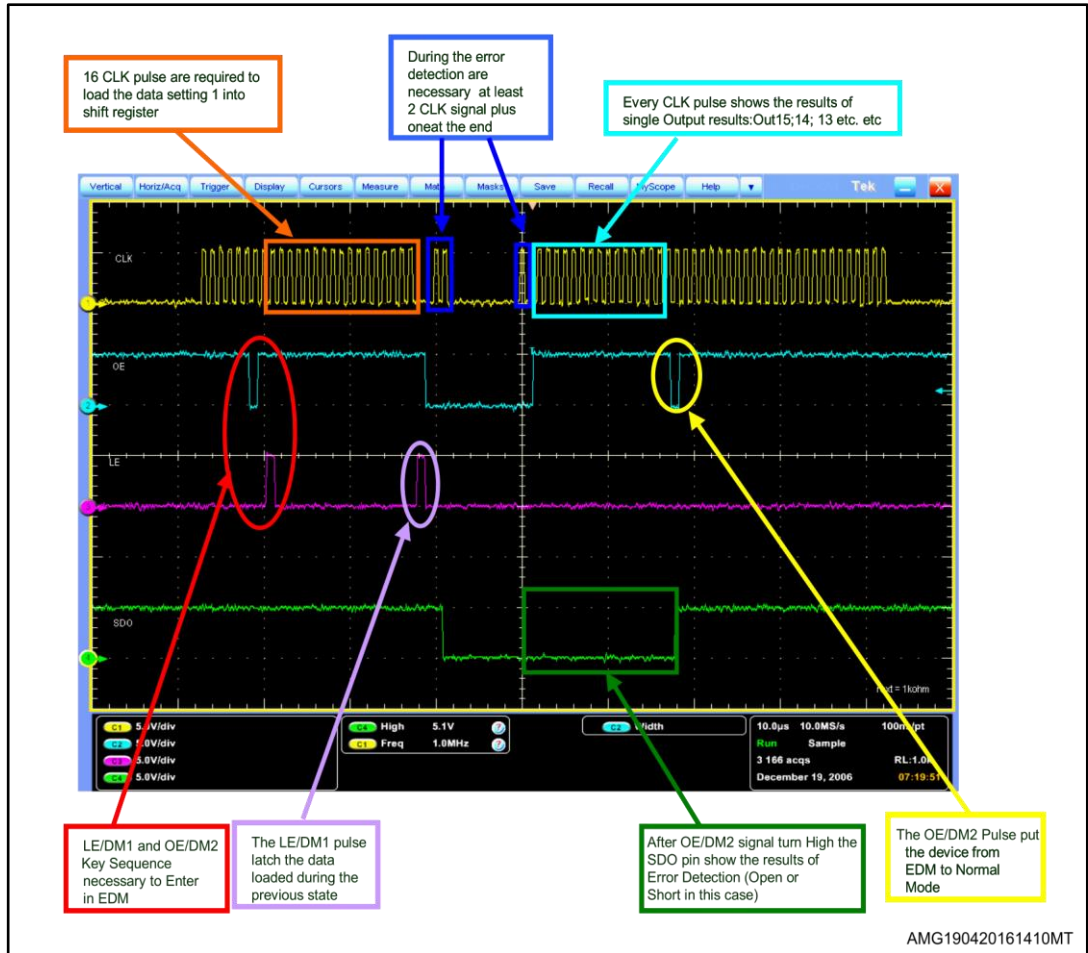

AMG190420161410MT

8 Package information

In order to meet environmental requirements, ST offers these devices in different grades of ECOPACK® packages, depending on their level of environmental compliance. ECOPACK® specifications, grade definitions and product status are available at: www.st.com. ECOPACK® is an ST trademark.

8.1 QSOP-24 package information

Figure 20: QSOP-24 package outline

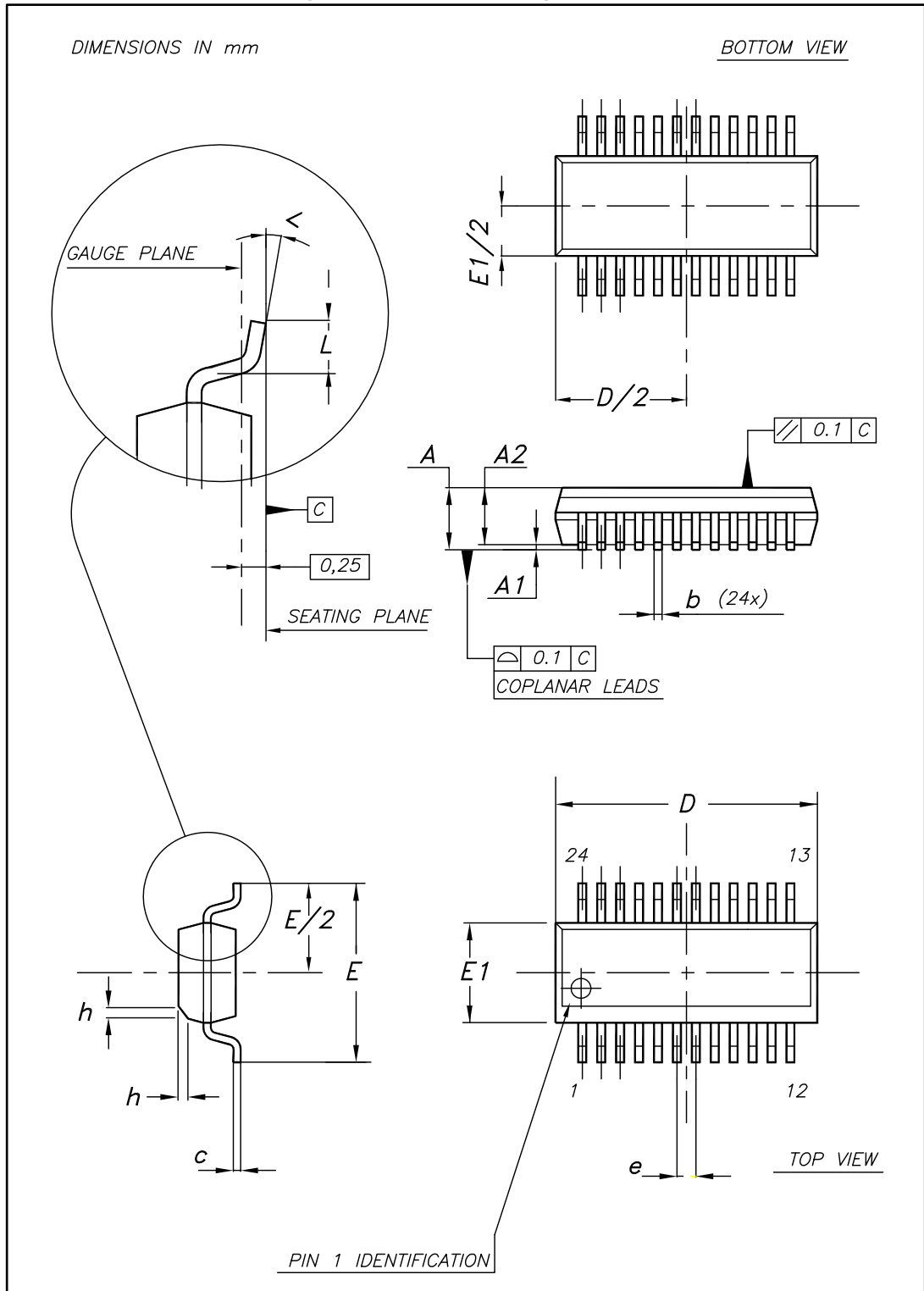
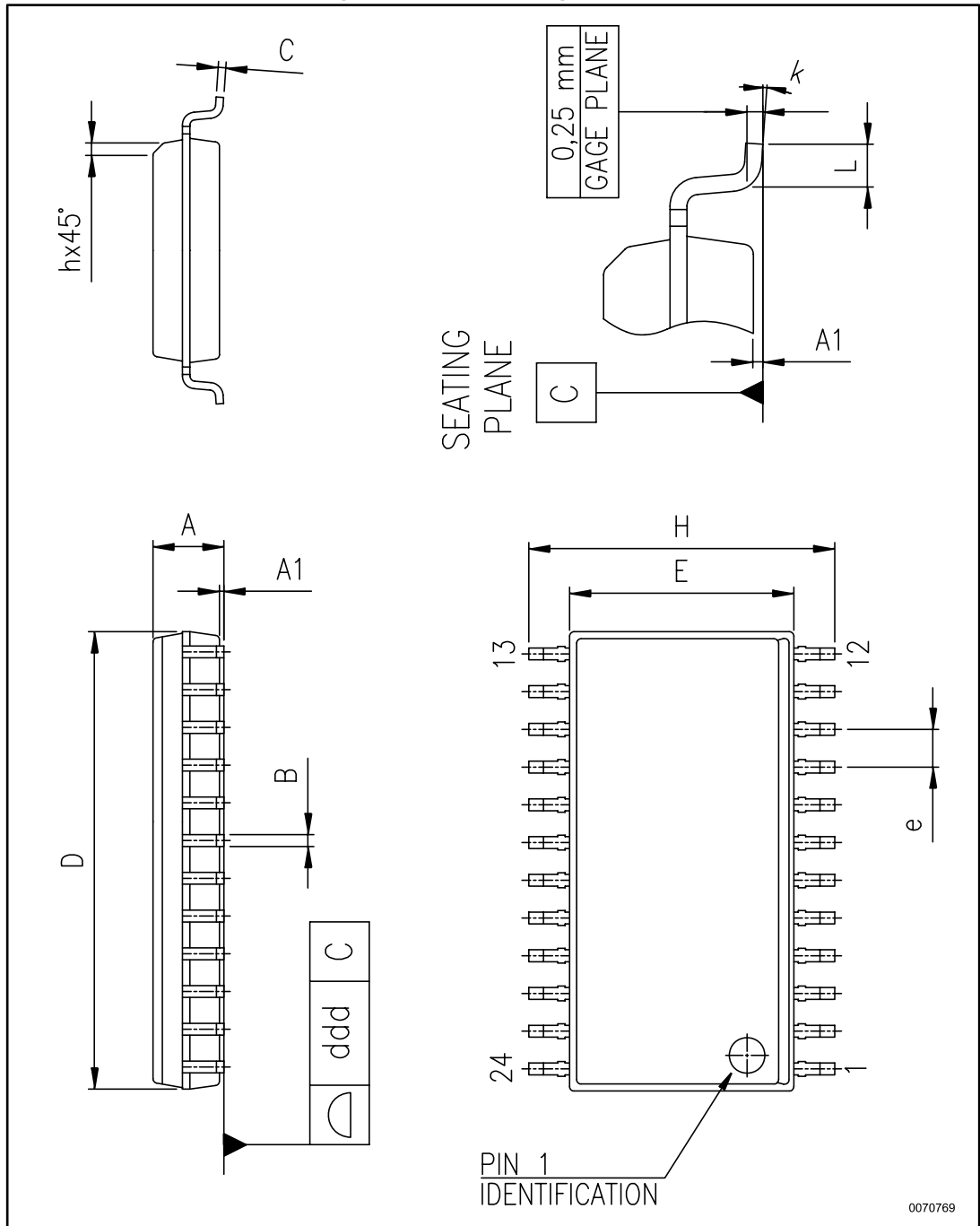

Table 15: QSOP-24 mechanical data

Dim.	mm		
	Min.	Typ.	Max.
A	1.54	1.62	1.73
A1	0.10	0.15	0.25
A2		1.47	
b	0.20		0.31
c	0.17		0.254
D	8.56	8.66	8.76
E	5.80	6.00	6.20
E1	3.80	3.91	4.01
e		0.635	
L	0.40	0.635	0.89
h	0.25	0.33	0.41
<	0°		8°

8.2 SO-24 package information

Figure 21: SO-24 package outline



0070769

Table 16: SO-24 mechanical data

Dim.	mm		
	Min.	Typ.	Max.
A	2.35		2.65
A1	0.10		0.30
B	0.33		0.51
C	0.23		0.32
D	15.20		15.60
E	7.40		7.60
e		1.27	
H	10.00		10.65
h	0.25		0.75
L	0.40		1.27
k	0		8
ddd			0.10

8.3 TSSOP24 package information

Figure 22: TSSOP24 package outline

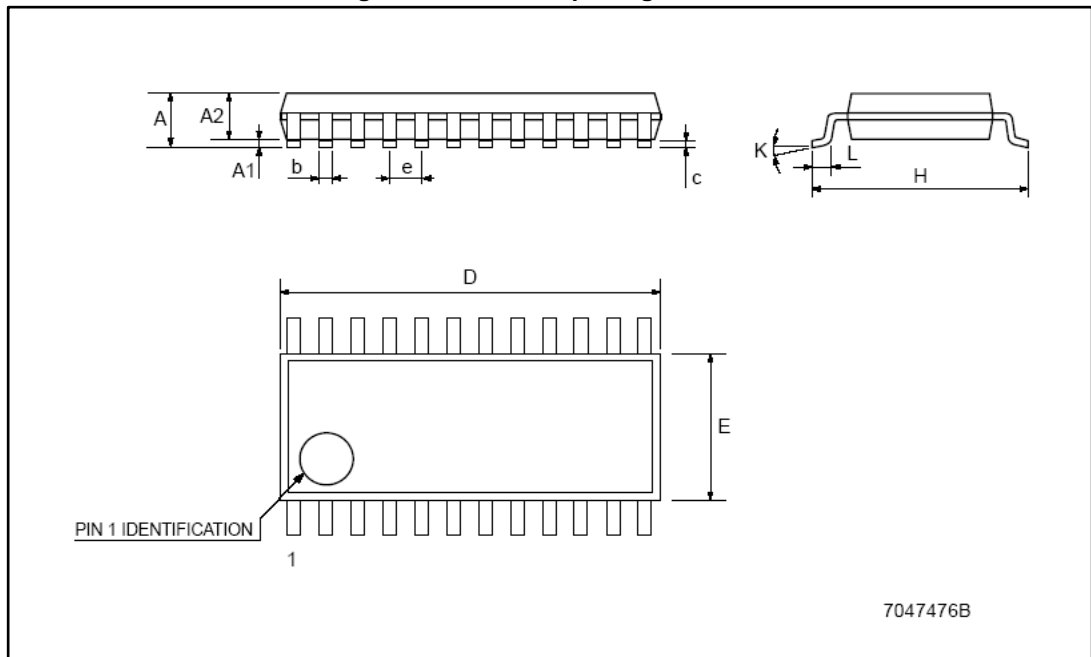

Table 17: TSSOP24 mechanical data

Dim.	mm		
	Min.	Typ.	Max.
A			1.1
A1	0.05		0.15
A2		0.9	
b	0.19		0.30
c	0.09		0.20
D	7.7		7.9
E	4.3		4.5
e		0.65 BSC	
H	6.25		6.5
K	0°		8°
L	0.50		0.70

8.4 TSSOP24 exposed pad package information

Figure 23: TSSOP24 exposed pad package outline

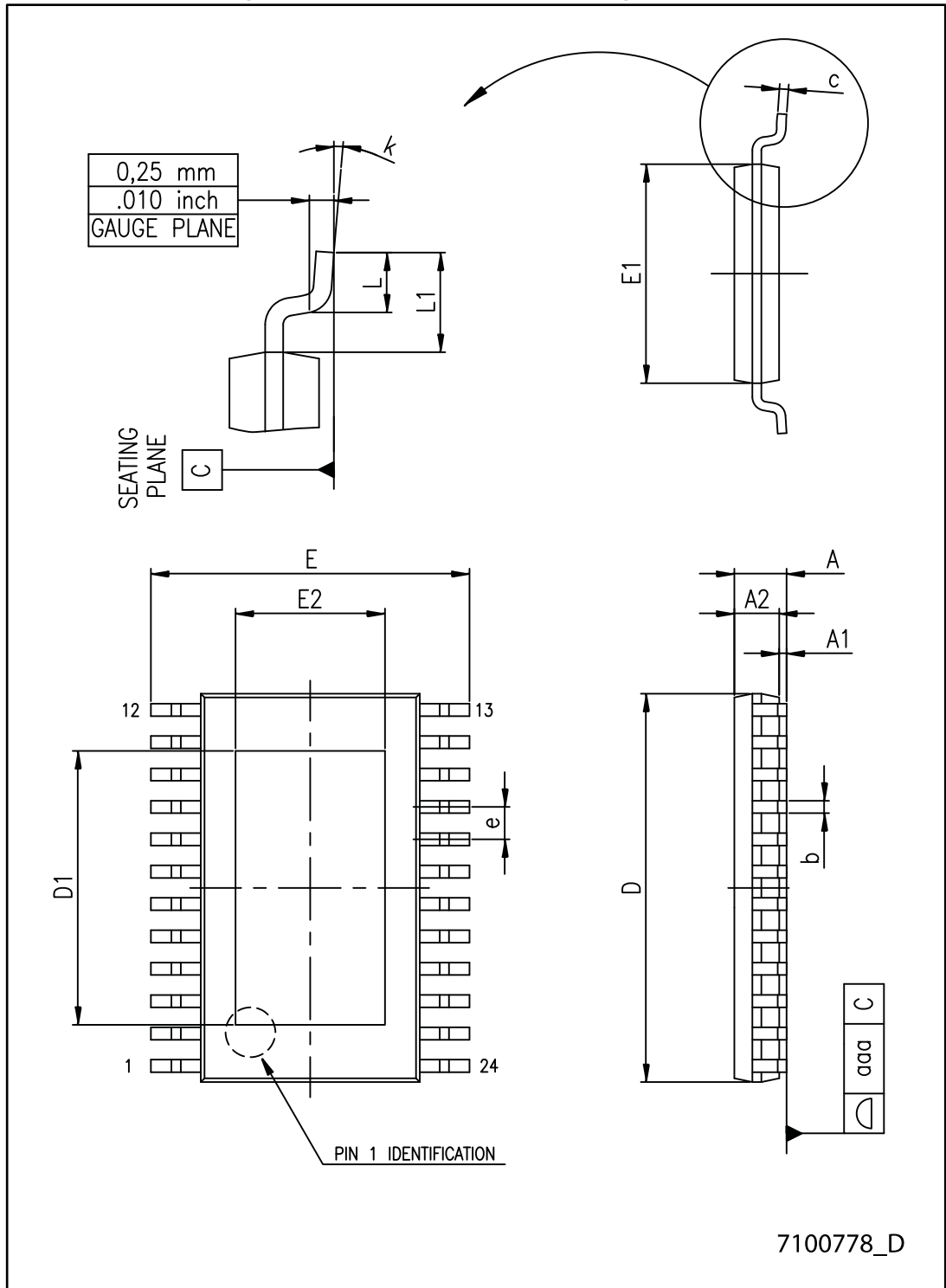

Table 18: TSSOP24 exposed pad mechanical data

Dim.	mm		
	Min.	Typ.	Max.
A			1.20
A1			0.15
A2	0.80	1.00	1.05
b	0.19		0.30
c	0.09		0.20
D	7.70	7.80	7.90
D1	4.80	5.00	5.2
E	6.20	6.40	6.60
E1	4.30	4.40	4.50
E2	3.00	3.20	3.40
e		0.65	
L	0.45	0.60	0.75
L1		1.00	
k	0°		8°
aaa			0.10

8.5 TSSOP24, TSSOP24 exposed pad and SO-24 packing information

Figure 24: TSSOP24, TSSOP24 exposed pad and SO-24 reel outline

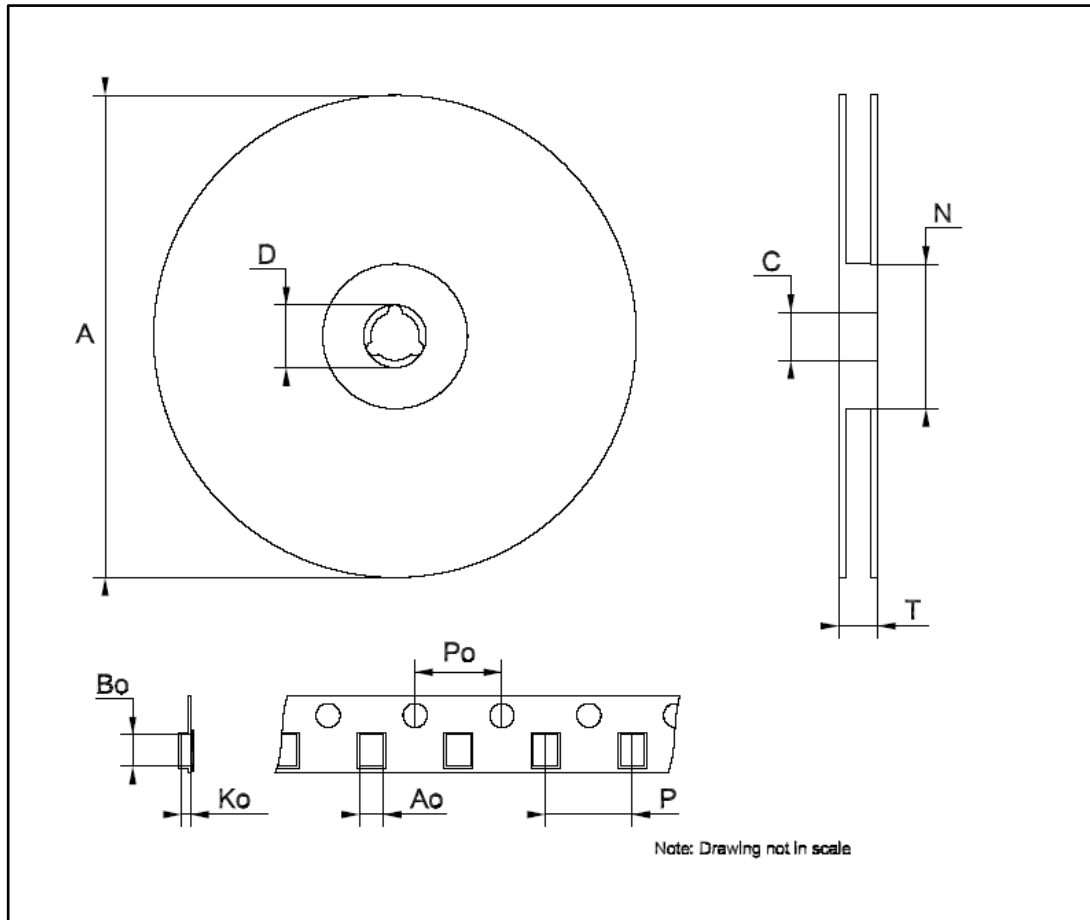

Table 19: TSSOP24 and TSSOP24 exposed pad tape and reel mechanical data

Dim.	mm		
	Min.	Typ.	Max.
A		-	330
C	12.8	-	13.2
D	20.2	-	
N	60	-	
T		-	22.4
Ao	6.8	-	7
Bo	8.2	-	8.4
Ko	1.7	-	1.9
Po	3.9	-	4.1
P	11.9	-	12.1

Table 20: SO-24 tape and reel mechanical data

Dim.	mm		
	Min.	Typ.	Max.
A		-	330
C	12.8	-	13.2
D	20.2	-	
N	60	-	
T		-	30.4
Ao	10.8	-	11.0
Bo	15.7	-	15.9
Ko	2.9	-	3.1
Po	3.9	-	4.1
P	11.9	-	12.1

9 Revision history

Table 21: Document revision history

Date	Revision	Changes
9-Jan-2007	1	First release
21-May-2007	2	Updated Table 7 on page 7
10-Jul-2007	3	Updated Table 9: Truth table on page 11
28-Feb-2008	4	Updated Table 15: TSSOP24 exposed-pad on page 23 Added QSOP-24 package information Table 14 and Figure 21 on page 24
23-Oct-2009	5	Updated Figure 7 on page 11, Chapter 3 on page 7
20-Jan-2010	6	Updated Table 5 on page 5
17-Jun-2014	7	Updated Section 8: Package mechanical data. Added Section 9: Packaging mechanical data. Minor text changes.
07-Nov-2017	8	Updated <i>Figure 5: "SDO terminal"</i> , <i>Figure 8: "Clock, serial-in, serial-out"</i> , <i>Figure 9: "Clock, serial-in, latch, enable, outputs"</i> and <i>Section 8: "Package information"</i> . Minor text changes.

IMPORTANT NOTICE – PLEASE READ CAREFULLY

STMicroelectronics NV and its subsidiaries ("ST") reserve the right to make changes, corrections, enhancements, modifications, and improvements to ST products and/or to this document at any time without notice. Purchasers should obtain the latest relevant information on ST products before placing orders. ST products are sold pursuant to ST's terms and conditions of sale in place at the time of order acknowledgement.

Purchasers are solely responsible for the choice, selection, and use of ST products and ST assumes no liability for application assistance or the design of Purchasers' products.

No license, express or implied, to any intellectual property right is granted by ST herein.

Resale of ST products with provisions different from the information set forth herein shall void any warranty granted by ST for such product.

ST and the ST logo are trademarks of ST. All other product or service names are the property of their respective owners.

Information in this document supersedes and replaces information previously supplied in any prior versions of this document.

© 2017 STMicroelectronics – All rights reserved

Looking for pricing, stock, or lifecycle information?

Click below to explore more details on WIN SOURCE:

- ⊖ [View STP16DP05MTR on WIN SOURCE](#)
- ⊖ [STMicroelectronics Information](#)

Optimize Your Supply Chain with WIN SOURCE Solutions

- ✓ Global Sourcing Solution
- ✓ Obsolete Management
- ✓ Cost Control Management
- ✓ Shortage Management
- ✓ Alternative Solution
- ✓ Excess Inventory Management