



THE DATASHEET OF STIL04-P5



APPLICATIONS

- High power density switching power supply
- Server and Telecom power supplies
- Game station power supplies
- High end TV displays
- Portable equipment adaptators

FEATURES

- Replaces two diodes of the bridge in steady state
- Dual unidirectional switches in a single package
- Inrush current limitation circuit for off-line power supply
- Designed for instantaneous response after AC line drop out or brownning
- Surge current capability as per IEC61000 4-5

BENEFITS

- Low consumption ($I_{P1} = 20\text{mA}$)
- High noise immunity: $dV/dt > 1000\text{V}/\mu\text{s}$ @ $T_j = -125^\circ\text{C}$
- Low reverse current losses
- Integrated pilot driver of the power switches
- Suitable where efficiency and space are critical

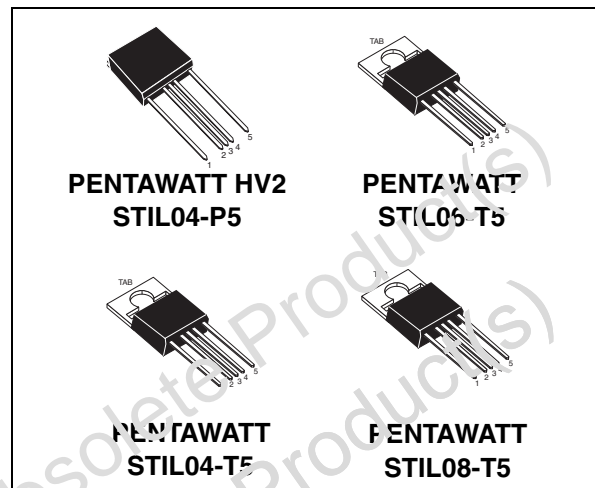
Table 1: Order Codes

Part Number	Marking
STIL04-P5	STIL04P5
STIL04-T5	STIL04T5
STIL06-T5	STIL06T5
STIL08-T5	STIL08T5

Table 2: Pin Out Description

Pin out designation	Description	Position
L	AC Line (switch1)	1
Pt1	Drive of power switch 1	2
OUT	Output	3
Pt2	Drive of power switch 2	4
N	AC Neutral (switch 2)	5

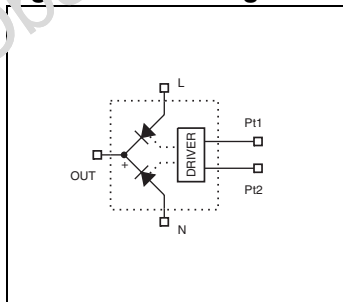
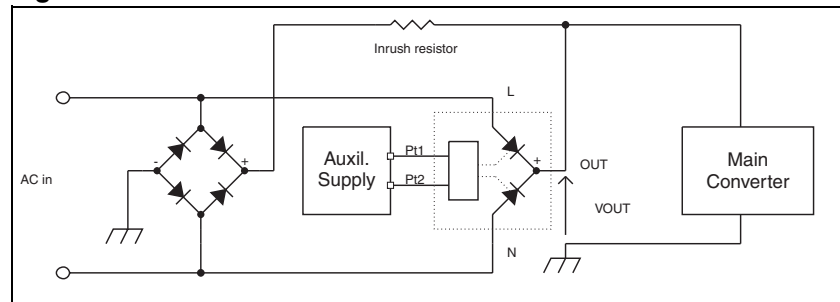
Figure 1: Block diagram

Figure 2: Basic connection

FUNCTIONAL DESCRIPTION IN A PFC BOOST PRE-REGULATOR

The STIL is connected in parallel with the diode bridge and the inrush power resistor. During start up, the two unidirectional ASD power switches of the STIL are open (Figure 3). The inrush current flows through the diodes of the bridge and external inrush power resistor. When the PFC reaches steady state, the auxiliary power supply coupled with the main transformer, supplies the energy required to feed the driver of the two power switches of the STIL (Figure 4). In steady state, the two DC ground connected diodes of the bridge rectifier and the two unidirectional switches of the STIL connected to DC+ rectify the AC line current.

Figure 3: Function description at turn-on

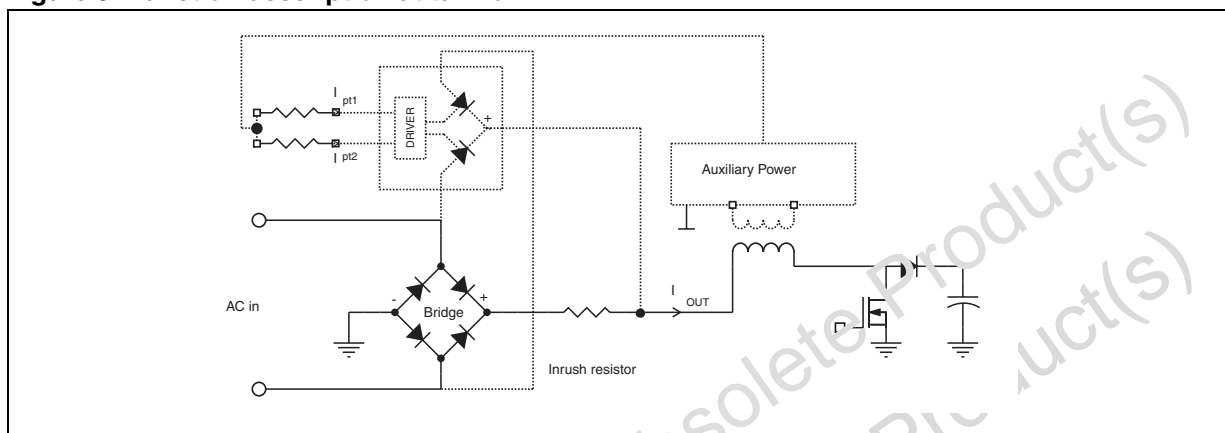
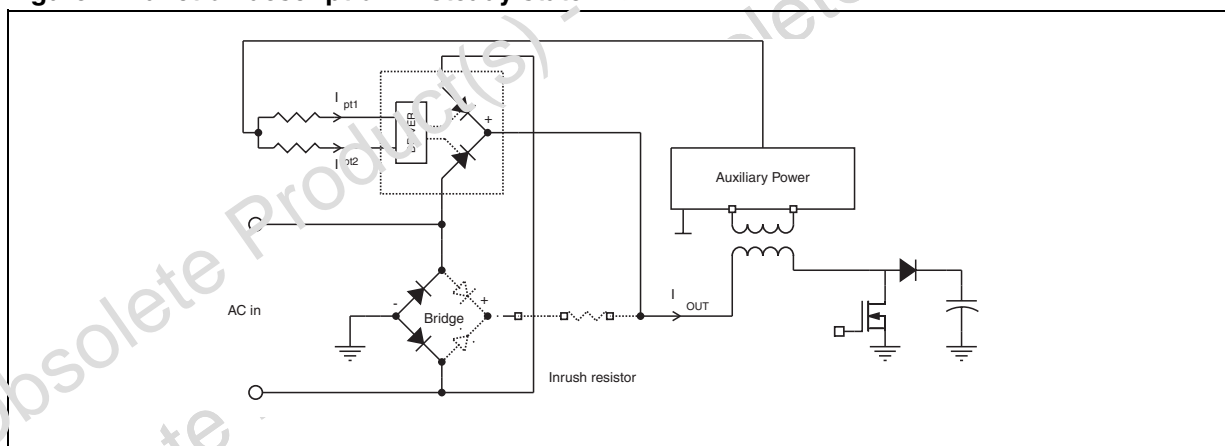

Figure 4: Function description in steady state



POWERFAIL FEATURE

When the STIL is used with a PFC boost converter, the inrush current circuit is active after an AC line drop-out. In that configuration, since the AC line disappears, the PFC controller and the auxiliary power supply of the STIL (Figure 8) turns OFF. The two switches of the STIL are open. The output bulk capacitor C_b is discharging and it is providing the energy to the main converter. When the AC line recovers, the two switches remain opened and recharging inrush current of the capacitor C_b is deviated and limited through the resistor R_i . When the capacitor had finished charging, the PFC turns ON again and the two switches of the STIL switch ON.

More details on the design and operation of the driver circuit of figure 5 can be found in the application note “AN1600 - STIL: Inrush Current Limitation Device for Off-Line Power Converter”.

Table 3: Absolute Maximum Ratings (limiting value)

Symbol	Parameter		Value			Unit
			STIL04	STIL06	STIL08	
V_{DOUT}	Repetitive forward off-state voltage, between terminals L or N and OUT terminal	$T_j = 0 \text{ to } 150^\circ\text{C}$	700			V
V_{ROUT}	Repetitive reverse off-state voltage, between OUT terminals and terminals L or N	$T_j = 0 \text{ to } 150^\circ\text{C}$	700	800	800	V
$I_{\text{out(AV)}}$	Average on state current at the OUT terminal (180° conduction angle for the internal power switches)	$T_j = 150^\circ\text{C}$	4	6	8	A
$I_{\text{out(RMS)}}$	RMS on state current at the OUT terminal (180° conduction angle for the internal power switches)	$T_j = 150^\circ\text{C}$	4.4	6.7	8.9	A
I_{TSM}	Non repetitive surge peak on-state current for each AC input terminals L and N (T_j initial = 25°C)	$t_p = 10\text{ms}$ sinusoidal	60	70	100	A
I^2t	I^2t value - rating for fusing	$t_p = 10\text{ms}$	21	24	50	A ² s
di_{out}/dt	Critical rate of rise of on state current $I_{\text{Pt1}} + I_{\text{Pt2}} = 20\text{mA}$	$T_j = 0 \text{ to } 150^\circ\text{C}$	100			A/ μs
T_{stg}	Storage temperature range		-40 to +150			°C
T_j	Junction temperature range		0 to +150			°C

Table 4: Thermal Parameters

Symbol	Parameter	Value	Unit
$R_{\text{th(j-c)}}$	Junction to case	2	°C/W
$R_{\text{th(j-a)}}$	Junction to ambient	60	

Table 5: Electrical Characteristics

Symbol	Parameter	Test conditions	Values									Unit	
			STIL04			STIL06			STIL08				
			Min.	Typ.	Max.	Min.	Typ.	Max.	Min.	Typ.	Max.		
$I_{Pt1} + I_{Pt2}$	Driver trigger current	$V_{Dout} = 12V(DC)$ $R_L = 30\Omega$	$T_j = 0^\circ C$		12	20		12	20		12	20	mA
			$T_j = 25^\circ C$		10			10			10		
$V_{D(Pt1)}$ $V_{D(Pt2)}$	Direct driver trigger voltage	$V_{Dout} = 12V(DC)$ $R_L = 30\Omega$	$T_j = 0^\circ C$	0.6	0.85	1		0.85	1		0.8	1	V
			$T_j = 25^\circ C$		0.8	0.95		0.8	0.95		0.75	0.9	
			$T_j = 150^\circ C$	0.2	0.45		0.2	0.45		0.2	0.4		
$V_{R(Pt1)}$ $V_{R(Pt2)}$	Maximum repetitive reverse driver voltage		$T_j = 25^\circ C$	8			8			8		V	
dV_{Dout}/dt	Dynamic voltage rising	Linear slope up to $V_{Dout} = 470V$	$T_j = 150^\circ C$	500			500			500		V/ μs	
			$T_j = 125^\circ C$	1000			1000			1000			
$I_{Rout (off)}^*$	Max reverse current without driver current	$V_{Rout} = 800V$ $I_{Pt1} = I_{Pt2} = open$	$T_j = 25^\circ C$			5		5			5	μA	
			$T_j = 150^\circ C$			300		300			300		
$I_{Rout (on)}^*$	Max reverse current with driver current	$V_{Rout} = 400V$ $I_{Pt1} = I_{Pt2} = 10mA$	$T_j = 150^\circ C$			300		300			300	μA	
V_{t0}	Threshold direct voltage for one power switch	$I_{out(AV)} = 4A$	$T_j = 150^\circ C$		0.75	0.9						V	
		$I_{out(AV)} = 6A$					0.75	0.9					
		$I_{out(AV)} = 8A$							0.75	0.9			
R_d	Dynamic resistance for one power switch	$I_{out(AV)} = 4A$	$T_j = 150^\circ C$		55	80						m Ω	
		$I_{out(AV)} = 6A$					45	50					
		$I_{out(AV)} = 8A$							30	40			
V_F^{**}	Forward voltage drop for one power switch	$I_{in} = 4A$	$T_j = 150^\circ C$		0.95	1.4						V	
		$I_{in} = 6A$					1.05	1.35					
		$I_{in} = 8A$							0.97	1.2			

Pulse test:

* $t_p = 300 \mu s, \delta < 2\%$ ** $t_p = 380 \mu s, \delta < 2\%$

POWER LOSSES CALCULATION

When the input current is sinusoidal (case of PFC), the conducted power losses can be calculated by using the following formula:

$$P_{tot} = V_{t0} \cdot I_{out(AV)} + R_d \cdot \frac{(I_{out(AV)} \times \pi)^2}{8}$$

If the output average current is 8Amps, V_{t0} and R_d of the electrical characteristics table can be used. For different output current please refer to the application note AN1600 that provides guidelines to estimate the correct values of V_{t0} and R_d .

LIGHTNING SURGE IMMUNITY (IEC61000-4-5)

During lightning surge transient voltage across the AC line, over current and over voltage stress are applied on all the components of the power supply. The STIL can sustain a maximum peak surge current up to I_{PEAK} ($I_{PEAK} = 500A$ for STIL04/STIL06 and $I_{PEAK} = 1000A$ for STIL08) as defined by the combine waveform generator (8/20 μ s waveform as shown in figures 5, 6 and 7).

Special recommendations for the lightning surge immunity:

- 1 - Check that the I_{PEAK} in the STIL stays below the limit specified above.
- 2 - Check that no over voltages are applied on the STIL and the bridge diode.
- 3 - In order to reduce the dynamic current stress (di_{out}/dt) through the structure of the STIL, it is recommended to connect a differential mode choke coil in front of the STIL and the bridge diode.

More details and design guidelines are provided in the application note "AN1600 - STIL: Inrush Current Limitation Device for Off-Line Power Converter".

Figure 5: Surge test condition

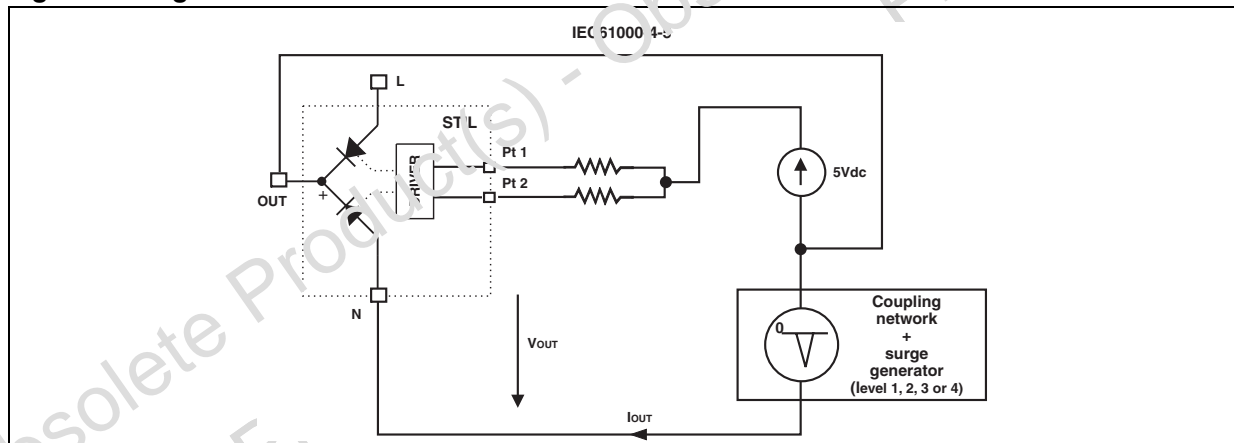

Figure 6: Surge test characterisation for STIL04/06

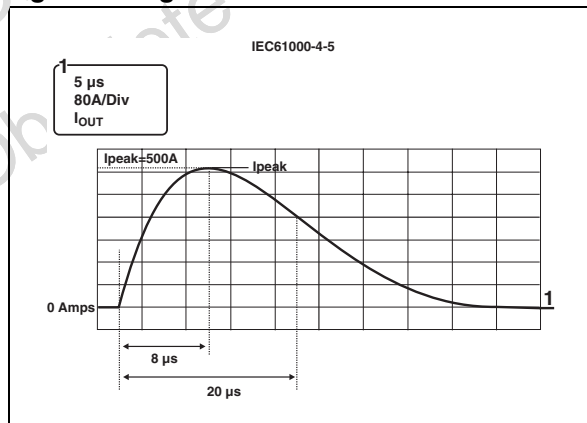

Figure 7: Surge test characterisation for STIL08

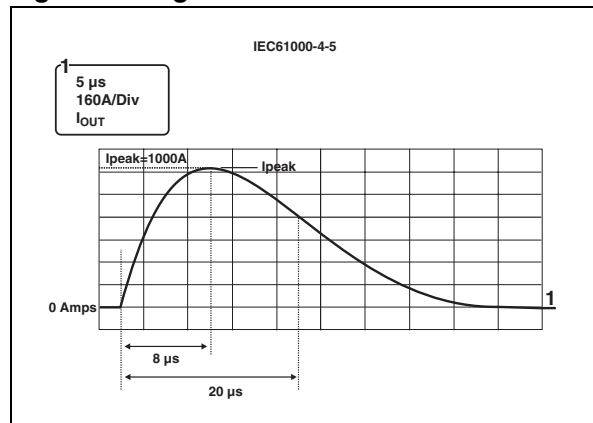

Figure 8: Basic connection with a PFC boost preregulator

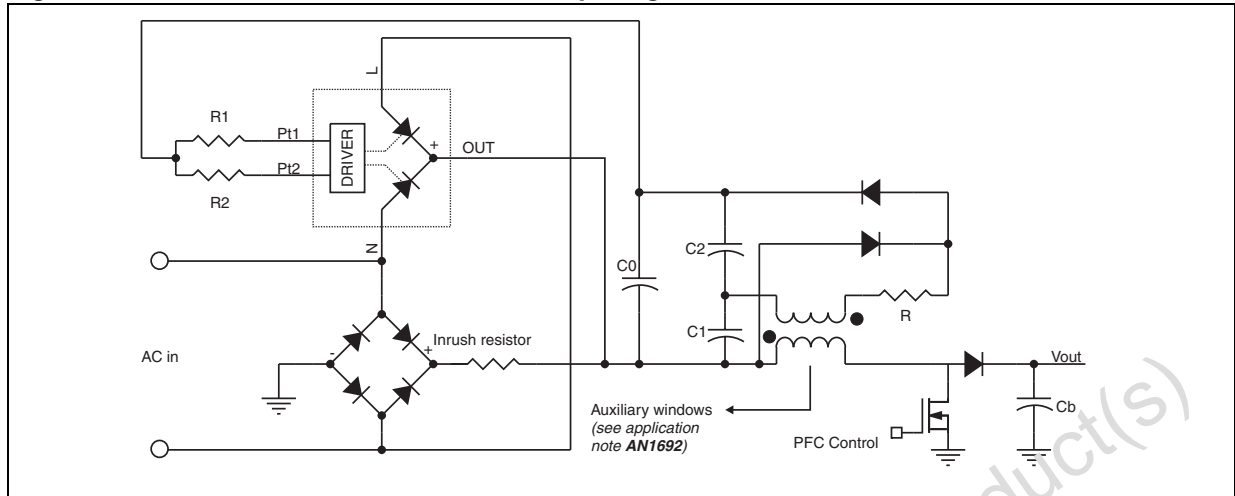

Figure 9: Non repetitive surge peak on-state current (sinusoidal pulse) and corresponding value of I^2t (T_j initial = 25°C)

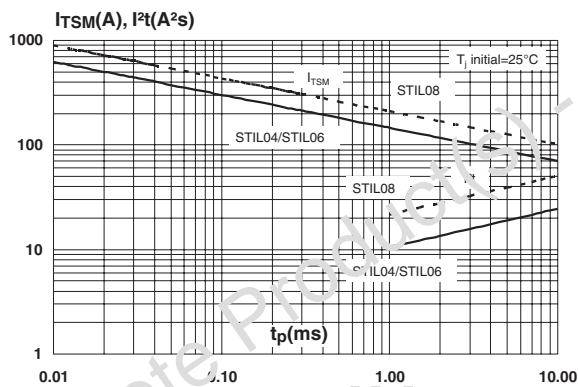

Figure 10: Non repetitive surge peak on-state current (sinusoidal pulse) and corresponding value of I^2t (T_j initial = 150°C)

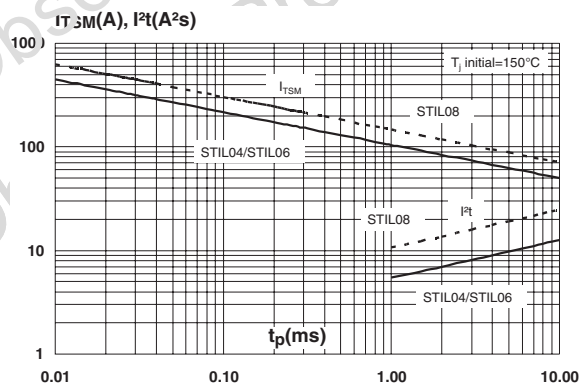

Figure 11: Relative variation of driver trigger current versus junction temperature (typical values)

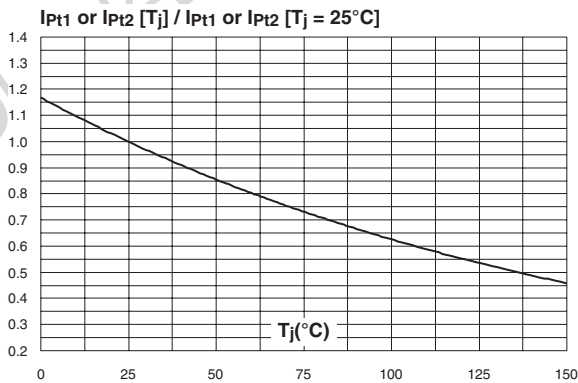

Figure 12: Relative variation of direct pilot trigger voltage versus junction temperature (typical values)

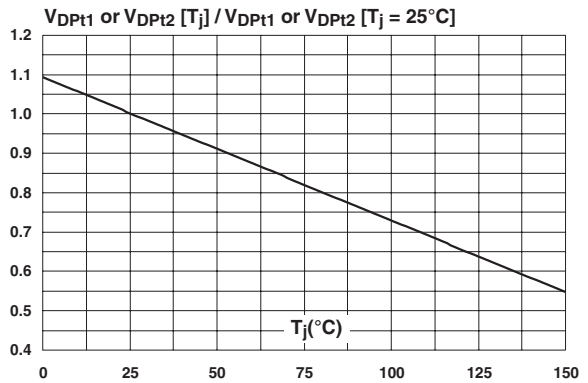

Figure 13: Relative variation of thermal impedance junction to case versus pulse duration

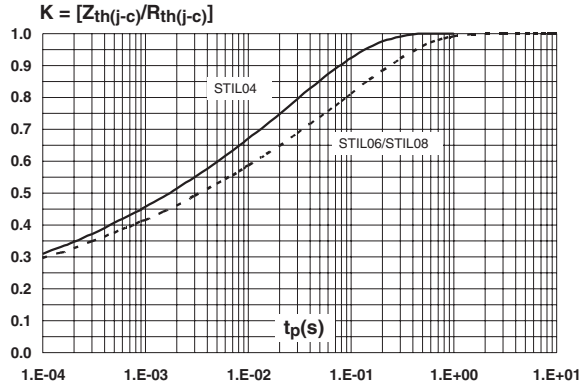

Figure 15: Reverse current versus junction temperature with driver current (typical values) (STIL04)

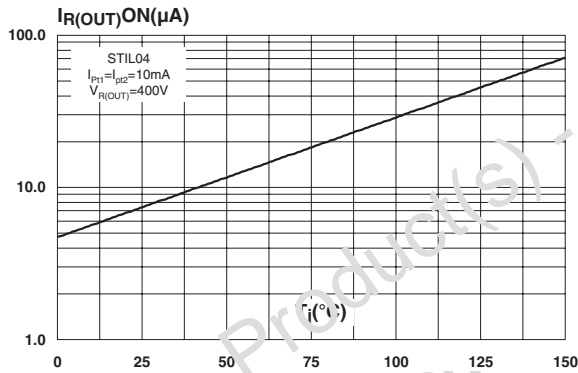

Figure 17: Reverse current versus junction temperature with driver current (typical values) (STIL08)

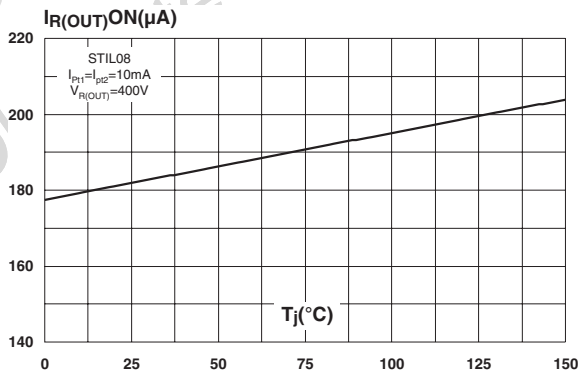

Figure 14: Reverse current versus junction temperature without driver current (typical values)

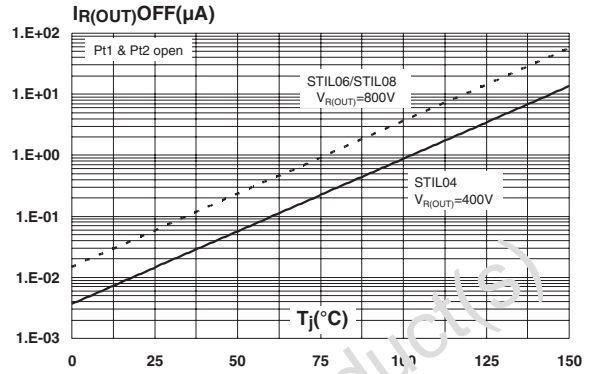

Figure 16: Reverse current versus junction temperature with driver current (typical values) (STIL06)

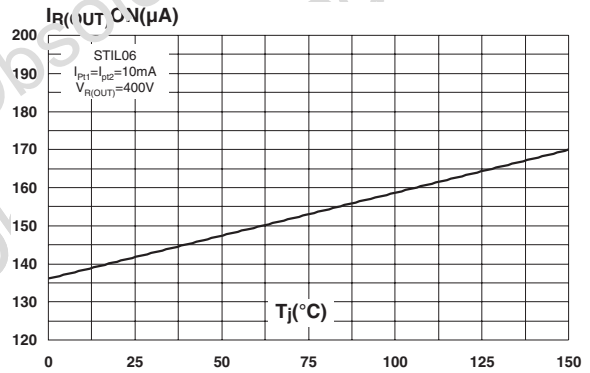

Figure 18: Forward voltage drop for one power switch versus junction temperature (typical values)

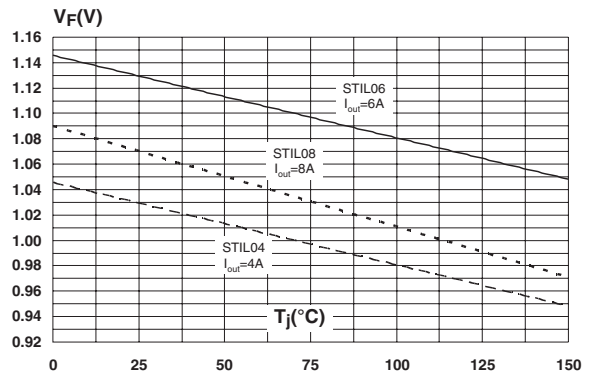

Figure 19: Peak forward voltage drop versus peak forward output current for one power switch (typical values) (STIL04)

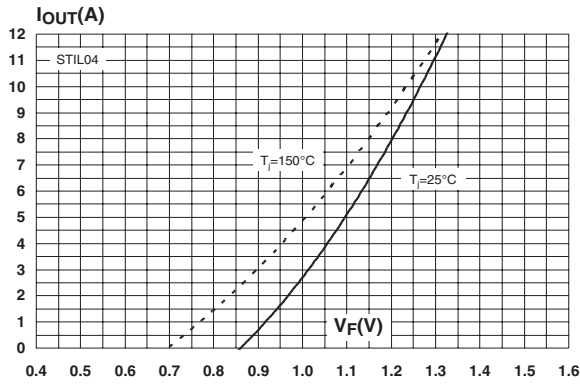

Figure 20: Peak forward voltage drop versus peak forward output current for one power switch (typical values) (STIL06)

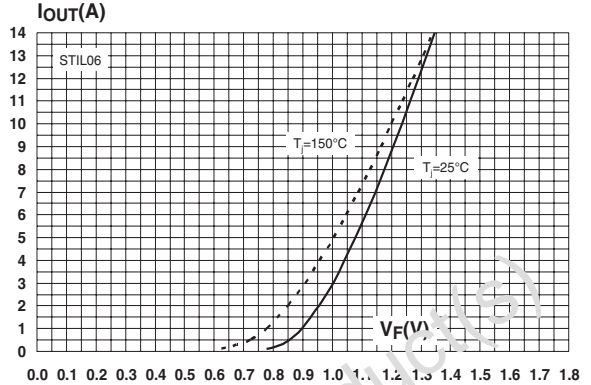

Figure 21: Peak forward voltage drop versus peak forward output current for one power switch (typical values) (STIL08)

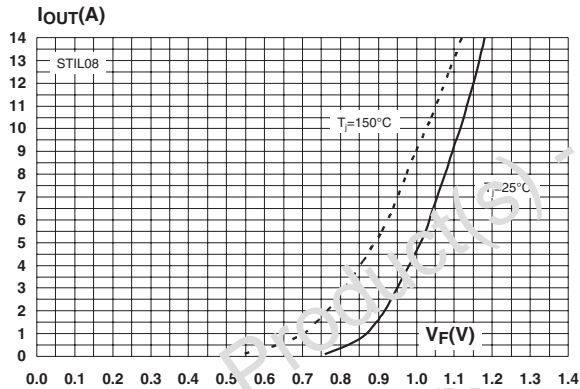

Figure 22: Relative variation of dV/dt immunity versus junction temperature (typical values)

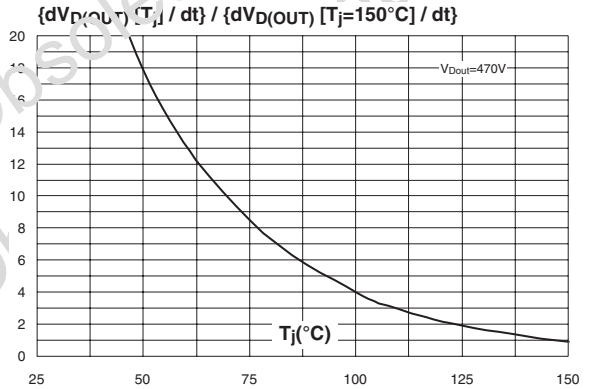

Figure 23: PENTAWATT HV2 Package Mechanical Data

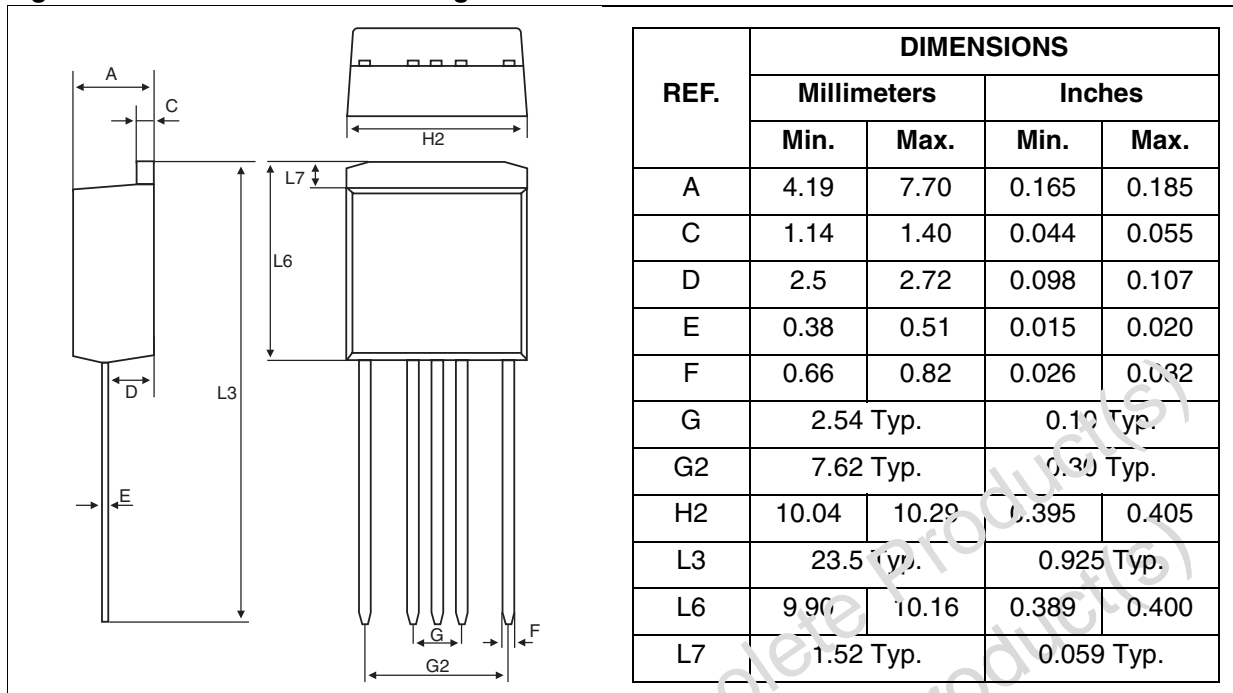
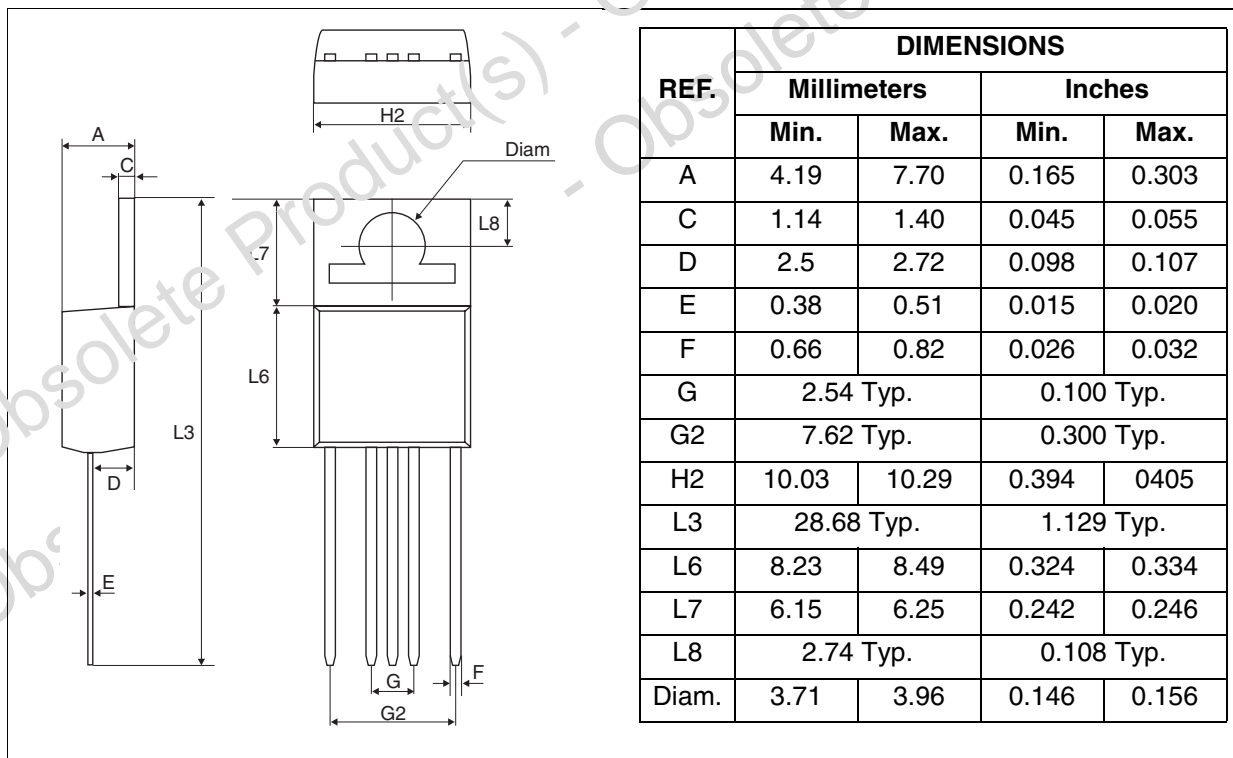

Figure 24: PENTAWATT Terminals Package Mechanical Data



In order to meet environmental requirements, ST offers these devices in ECOPACK® packages. These packages have a Lead-free second level interconnect . The category of second level interconnect is marked on the package and on the inner box label, in compliance with JEDEC Standard JESD97. The maximum ratings related to soldering conditions are also marked on the inner box label. ECOPACK is an ST trademark. ECOPACK specifications are available at: www.st.com.

Table 6: Ordering Information

Part Number	Marking	Package	Weight	Base qty	Delivery mode
STIL04-P5	STIL04P5	PENTAWATT HV2	1.9 g	50	Tube
STIL04-T5	STIL04T5	PENTAWATT	3 g	50	Tube
STIL06-T5	STIL06T5	PENTAWATT	3 g	50	Tube
STIL08-T5	STIL08T5	PENTAWATT	3 g	50	Tube

- Epoxy meets UL94, V0
- Cooling method: by conduction (C)
- Recommended torque value: 0.8 Nm.

Table 7: Revision History

Date	Revision	Description of Changes
October-2002	3	Last update.
23-Nov-2004	4	STIL08-T5 added
06-Dec-2005	5	STIL04-T5 and STIL06-T5 added. ECOPAK statement added

Obsolete Product(s) - Obsolete Product(s)
Obsolete Product(s) - Obsolete Product(s)

Information furnished is believed to be accurate and reliable. However, STMicroelectronics assumes no responsibility for the consequences of use of such information nor for any infringement of patents or other rights of third parties which may result from its use. No license is granted by implication or otherwise under any patent or patent rights of STMicroelectronics. Specifications mentioned in this publication are subject to change without notice. This publication supersedes and replaces all information previously supplied. STMicroelectronics products are not authorized for use as critical components in life support devices or systems without express written approval of STMicroelectronics.

The ST logo is a registered trademark of STMicroelectronics.
All other names are the property of their respective owners



© 2005 STMicroelectronics - All rights reserved

STMicroelectronics group of companies

Australia - Belgium - Brazil - Canada - China - Czech Republic - Finland - France - Germany - Hong Kong - India - Israel - Italy - Japan -
Malaysia - Malta - Morocco - Singapore - Spain - Sweden - Switzerland - United Kingdom - United States of America
www.st.com

Looking for pricing, stock, or lifecycle information?

Click below to explore more details on WIN SOURCE:

-  [View STIL04-P5 on WIN SOURCE](#)
-  [STMicroelectronics Information](#)

Optimize Your Supply Chain with WIN SOURCE Solutions

-  Global Sourcing Solution
-  Obsolete Management
-  Cost Control Management
-  Shortage Management
-  Alternative Solution
-  Excess Inventory Management