



# THE DATASHEET OF STHDMI001ATTR





# STHDMI001A

3.3V, high bandwidth, 2-to-1 high definition multimedia interface (HDMI) switch with single enable

## Features

- Compatible with HDMI v1.1 and DVI v1.0 digital interfaces
- Data rate per channel for UXGA: 1.65Gbps
- 165MHz speed operation supports all video formats up to 1080p and SXGA (1280x1024 at 75 Hz)
- Low  $R_{ON}$ : 5.5  $\Omega$ (typ)
- $V_{CC}$  operating range: 3.0V to 3.6V
- Low current consumption: 20 $\mu$ A
- ESD human body model HBM Voltage:
  - $\pm$ 2KV for all I/Os
- Channel ON capacitance: 6pF (typ)
- Switching speed: 9ns
- Near-zero propagation delay: 250ps
- Low crosstalk: -32dB at 825MHz
- Bit-to-bit skew: 200ps
- Very low ground bounce in flow through mode
- Data and control inputs provide an undershoot clamp diode
- Wide bandwidth minimizes skew and jitter
- Hot insertion capable
- Supports bi-directional operation
- Available in the TSSOP48 package
- -40°C to 85°C operating temperature range



## Description

The STHDMI001A is a differential Single Pole Double Throw (SPDT) 2-to-1, low  $R_{ON}$ , bidirectional HDMI switch. It is designed to support HDMI/DVI television systems that produce superior high-definition image quality. The differential signal from the 2 HDMI ports is multiplexed through the switch to form a single output HDMI channel going to the HDMI receiver, while the deselected output goes to the high-Z (high impedance) state. It is designed for very low crosstalk, low bit-to-bit skew, high channel-to-channel noise isolation, and low I/O capacitance. This switch offers very little high-speed signal attenuation at the outputs, thus preserving the signal integrity necessary to pass stringent interference requirements. STHDMI001A provides the ability to switch a single source output to various display devices or switch video display devices between multiple sources. It reduces the overall BOM costs by eliminating the need for more costly multi input output controllers

## Applications

- DVD Players
- Front projectors
- LCD TVs and monitors
- Notebook PCs
- PDPs

## Order codes

Part number	Temperature range	Package	Comments
STHDMI001A	-65°C to +150°C	TSSOP48	STHDMI001ATTR

---

## Contents

<b>1</b>	<b>Summary description</b> .....	<b>3</b>
1.1	Functional description .....	3
1.2	Function table .....	5
<b>2</b>	<b>Maximum rating</b> .....	<b>6</b>
<b>3</b>	<b>DC and AC parameters</b> .....	<b>7</b>
3.1	Capacitance .....	8
3.2	Power supply .....	8
<b>4</b>	<b>Dynamic characteristics</b> .....	<b>9</b>
4.1	Timing characteristics .....	11
<b>5</b>	<b>ESD performance</b> .....	<b>13</b>
<b>6</b>	<b>Package mechanical data</b> .....	<b>14</b>
<b>7</b>	<b>Revision history</b> .....	<b>16</b>

# 1 Summary description

## 1.1 Functional description

The STHDMI001A routes physical layer signals for high bandwidth digital video and is compatible with low voltage differential signaling standards like Transition Minimized Differential Signaling (TMDS). The device multiplexes differential outputs from a video source to one of the two corresponding outputs, then to a common display. The low ON resistance ( $R_{ON}$ ) and low I/O capacitance of the STHDMI001A result in a very small propagation delay. The device integrates SPDT-type switches for 3 differential data TMDS channels and 1 differential clock channel.

Figure 1. Connections diagram

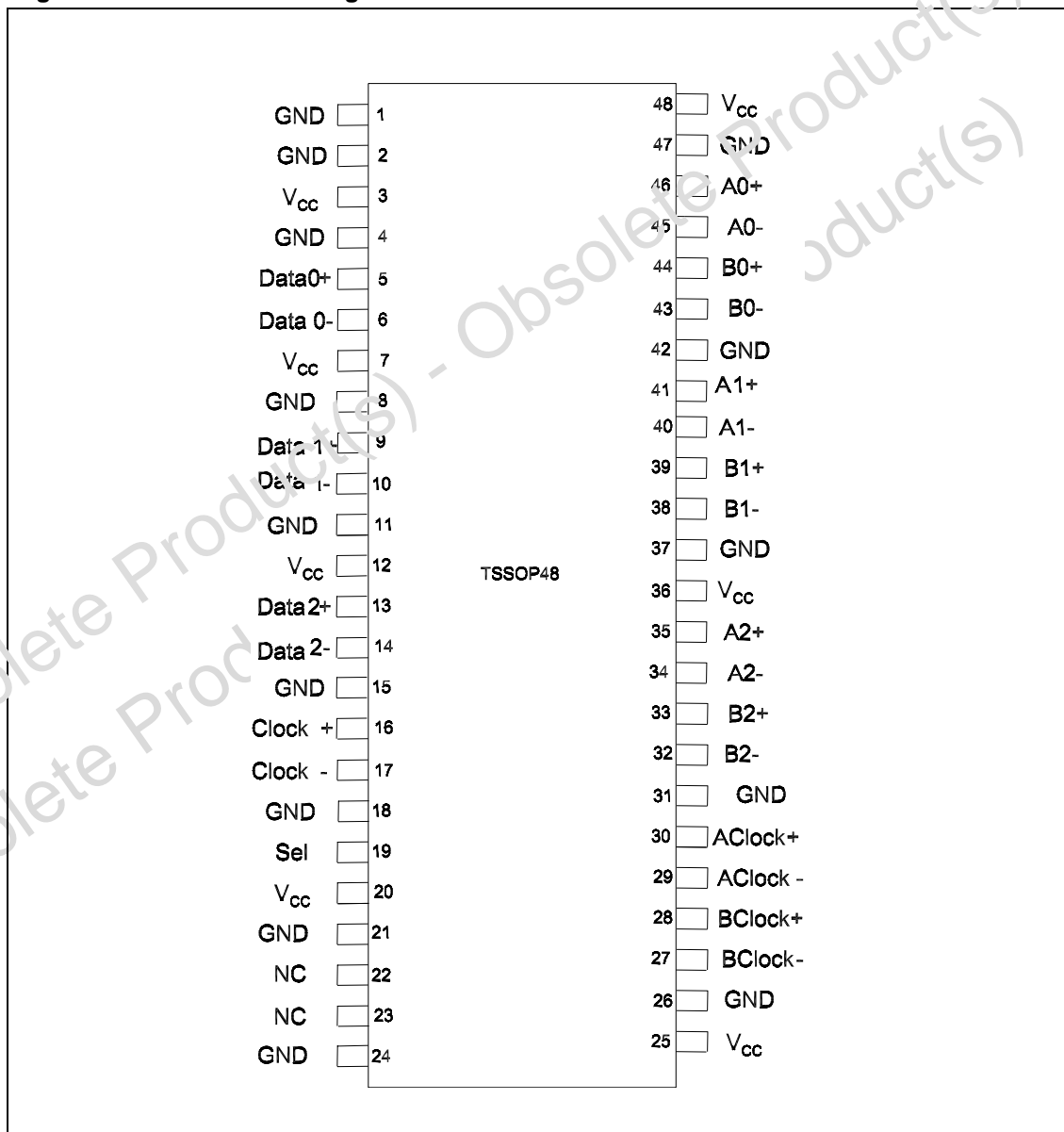
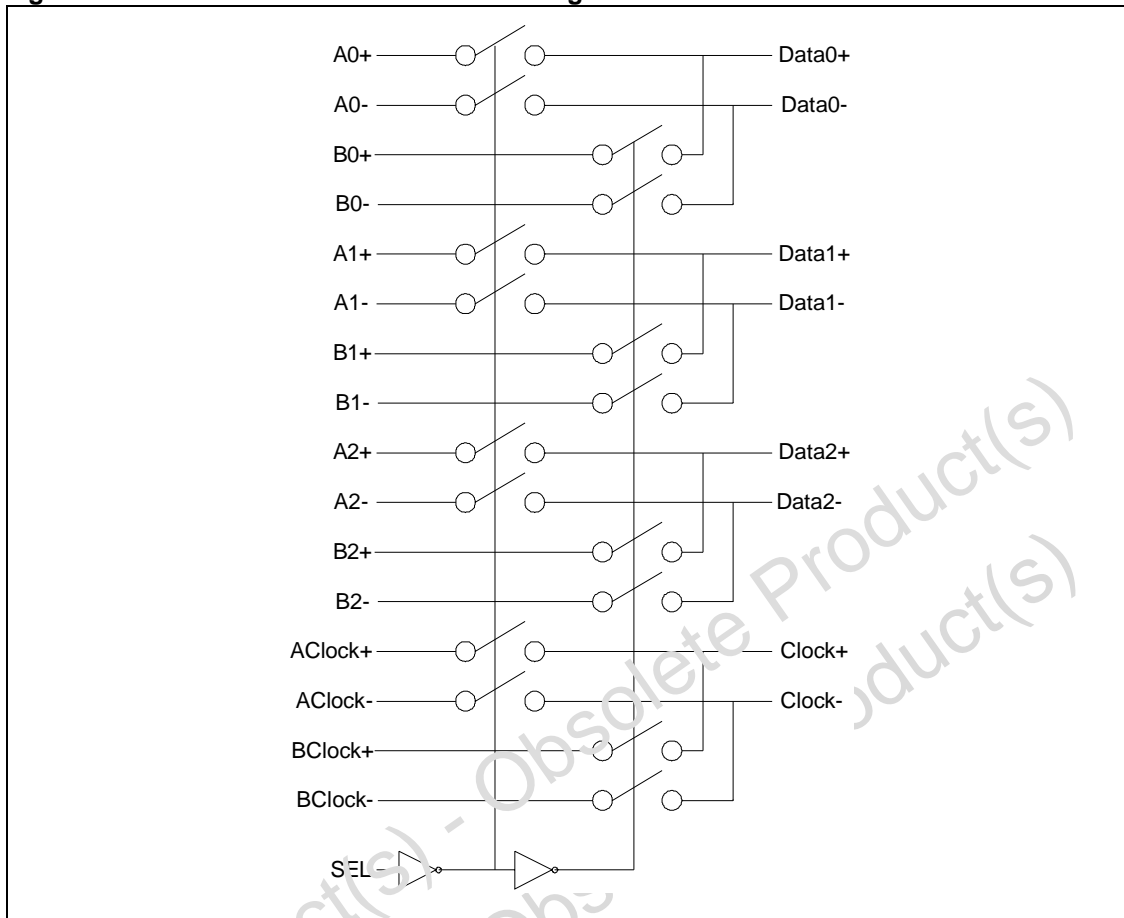

Table 1. Pin description

Pin Number	Pin Name	Type	Function
1	GND	Power	Ground
2	GND	Power	Ground
3	V <sub>CC</sub>	Power	Supply Voltage (3.3V ± 10%)
4	GND	Power	Ground
5	Data0+	Output	TMDS Data0+ Output
6	Data0-	Output	TMDS Data0- Output
7	V <sub>CC</sub>	Power	Supply Voltage (3.3V ± 10%)
8	GND	Power	Ground
9	Data1+	Output	TMDS Data1+ Output
10	Data1-	Output	TMDS Data1- Output
11	GND	Power	Ground
12	V <sub>CC</sub>	Power	Supply Voltage (3.3V ± 10%)
13	Data2+	Output	TMDS Data2+ Output
14	Data2-	Output	TMDS Data2- Output
15	GND	Power	Ground
16	Clock+	Output	TMDS Clock+ Output
17	Clock-	Output	TMDS Clock- Output
18	GND	Power	Ground
19	SEL	Input	Select Control input to select port A or port B
20	V <sub>CC</sub>	Power	Supply Voltage (3.3V ± 10%)
21	GND	Power	Ground
22, 23	NC		Not Connected
24	GND	Power	Ground
25	V <sub>CC</sub>	Power	Supply Voltage (3.3V ± 10%)
26	GND	Power	Ground
27	BClock-	Input	TMDS Clock- for port B
28	BClock+	Input	TMDS Clock+ for port B
29	AClock-	Input	TMDS Clock- for port A
30	AClock+	Input	TMDS Clock+ for port A
31	GND	Power	Ground
32	B2-	Input	TMDS Data2- for port B
33	B2+	Input	TMDS Data2+ for port B
34	A2-	Input	TMDS Data2- for port A
35	A2+	Input	TMDS Data2+ for port A
36	V <sub>CC</sub>	Power	Supply Voltage (3.3V ± 10%)
37	GND	Power	Ground
38	B1-	Input	TMDS Data1- for port B
39	B1+	Input	TMDS Data1+ for port B
40	A1-	Input	TMDS Data1- for port A
41	A1+	Input	TMDS Data1+ for port A
42	GND	Power	Ground
43	B0-	Input	TMDS Data0- for port B
44	B0+	Input	TMDS Data0+ for port B
45	A0-	Input	TMDS Data0- for port A
46	A0+	Input	TMDS Data0+ for port A
47	GND	Power	Ground
48	V <sub>CC</sub>	Power	Supply Voltage (3.3V ± 10%)

**Figure 2. 2-to-1 HDMI switch functional diagram**



## 1.2 Function table

**Table 2. Functions**

Selection	Function
L	TMDS Data and Clock for Port A
H	TMDS Data and Clock for Port B

## 2 Maximum rating

Stressing the device above the rating listed in the “Absolute Maximum Ratings” table may cause permanent damage to the device. These are stress ratings only and operation of the device at these or any other conditions above those indicated in the Operating sections of this specification is not implied. Exposure to Absolute Maximum Rating conditions for extended periods may affect device reliability. Refer also to the STMicroelectronics SURE Program and other relevant quality documents.

**Table 3. Absolute maximum ratings**

Symbol	Parameter	Value	Unit
$V_{CC}$	Supply Voltage to Ground	-0.5 to + 4.0	V
$V_S$	DC Input Voltage	-0.5 to + 4.0	V
$V_{IC}$	DC Control Input Voltage	-0.5 to + 4.0	V
$I_O$	DC Output Voltage	120	mA
$T_{STG}$	Storage Temperature	-65 to 150	°C
$T_L$	Lead Temperature (10sec)	300	°C

*Note:* Absolute maximum ratings are those values above which damage to the device may occur. Functional operation under these conditions is not implied. All voltages are referenced to GND.

**Table 4. Thermal data**

Symbol	Description	Value	Unit
$R_{thJA}$	Thermal Resistance Junction-ambient	59	°C/W

### 3 DC and AC parameters

**Table 5. Electrical characteristics**

Symbol	Parameter	Test conditions <sup>1</sup>	Min.	Typ.	Max.	Unit
V <sub>IH</sub>	HIGH Level Input Voltage	High Level Guaranteed	2.0			V
V <sub>IL</sub>	LOW Level Input Voltage	Low Level Guaranteed	-0.5		0.8	V
V <sub>IK</sub>	Clamp Diode Voltage	V <sub>CC</sub> = 3.6V, I <sub>IN</sub> = -18mA		-0.8	-1.2	V
I <sub>IH</sub>	Input High Current	V <sub>CC</sub> = 3.6V, I <sub>IN</sub> = V <sub>CC</sub>			±5	μA
I <sub>IL</sub>	Input Low Current	V <sub>CC</sub> = 3.6V, I <sub>IN</sub> = GND			±5	μA
I <sub>OFF</sub>	Power Down Leakage Current	V <sub>CC</sub> = 0V; Data0+, Data0-, Data1+, Data1-, Data2+, Data2-, Clock+, Clock- = 0V; A0+ to AClock- and B0+ to BClock- = 3.6V			±5	μA
R <sub>ON</sub>	Switch ON resistance (Note 2)	V <sub>CC</sub> = 3.0V, V <sub>IN</sub> = 1.5 to V <sub>CC</sub> I <sub>IN</sub> = -40mA		5.5	7.5	Ω
R <sub>FLAT</sub>	ON resistance flatness (Note 2,3)	V <sub>CC</sub> = 3.0V, V <sub>IN</sub> = 1.5 to V <sub>CC</sub> I <sub>IN</sub> = -40mA		0.8		Ω
ΔR <sub>ON</sub>	ON resistance match between channels ΔR <sub>ON</sub> = R <sub>ONMAX</sub> - R <sub>ONMIN</sub> (Note 3,4)	V <sub>CC</sub> = 3.0V, V <sub>IN</sub> = 1.5 to V <sub>CC</sub> I <sub>IN</sub> = -40mA		0.5	1	Ω

Note: 1 Valid for Ambient Operating Temperature: T<sub>A</sub> = -40 to 85°C; V<sub>CC</sub> = 3.3V ± 10% (except where noted).

2 Measured by voltage drop between channels at the indicated current through the switch. On-resistance is determined by the lower of the two voltages.

3 Flatness is defined as the difference between the R<sub>ONMAX</sub> and the R<sub>ONMIN</sub> of the on resistance over the specified range.

4 ΔR<sub>ON</sub> measured at the same V<sub>CC</sub>, temperature and voltage level.

### 3.1 Capacitance

**Table 6. Capacitance**

Symbol	Parameter	Test Conditions	Min.	Typ.	Max.	Unit
C <sub>IN</sub>	Input Capacitance ( <i>Note:4</i> )	V <sub>IN</sub> = 0V		2	3	pF
C <sub>OFF</sub>	Port x0 to Port x1, Switch Off ( <i>Note:4</i> )	V <sub>IN</sub> = 0V		4	6	pF
C <sub>ON</sub>	Capacitance Switch on (x to x0 or x to x1) ( <i>Note:4</i> )	V <sub>IN</sub> = 0V		7.5	11	pF

*Note:* 4. x = Data0+, Data0-, Data1+, Data1-, Data2+, Data2-, Clock+, Clock-  
 X0 = A0+, A0-, A1+, A1-, A2+, A2-, AClock+, AClock-  
 X1 = B0+, B0-, B1+, B1-, B2+, B2-, BClock+, BClock-

### 3.2 Power supply

**Table 7. Power supply characteristics**

Symbol	Parameter	Test conditions	Min.	Typ.	Max.	Unit
I <sub>CC</sub>	Quiescent Power Supply Current	V <sub>CC</sub> = 3.6 V, V <sub>IN</sub> = V <sub>CC</sub> or GND		150	500	μA

*Note:* Valid for Ambient Operating Temperature: T<sub>A</sub> = -40 to 85°C; V<sub>CC</sub> = 3.3V ± 10% (except where noted).

## 4 Dynamic characteristics

Figure 3. Measurement circuit

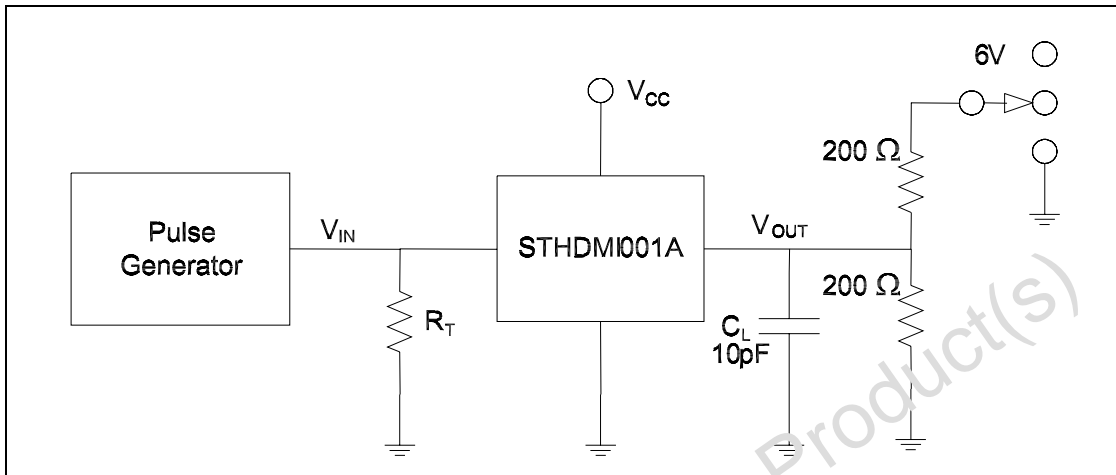

$C_L$  = Load Capacitance: includes jig and probe capacitance.

$R_T$  = Termination Resistance: should be equal to  $Z_{OUT}$  of the Pulse Generator.

Table 8. Dynamic characteristics

Symbol	Parameter	Test conditions	Min.	Typ.	Max.	Unit
$X_{TALK}$	Non-adjacent channel Cross-talk	$R_L = 100\Omega, f = 250\text{MHz}$		-45		dB
		$R_L = 100\Omega, f = 370\text{MHz}$		-42		dB
		$R_L = 100\Omega, f = 825\text{MHz}$		-32		dB
$C_{IRR}$	Off Isolation	$R_L = 100\Omega, f = 250\text{MHz}$		-40		dB
		$R_L = 100\Omega, f = 370\text{MHz}$		-36		dB
		$R_L = 100\Omega, f = 500\text{MHz}$		-30		dB
		$R_L = 100\Omega, f = 825\text{MHz}$		-25		dB
$D_R$	Data rate per channel			1.65		Gbps

Note: Valid for Ambient Operating Temperature:  $T_A = -40$  to  $85^\circ\text{C}$ ;  $V_{CC} = 3.3\text{V} \pm 10\%$  (except where noted).

**Table 9. Dynamic switching characteristics**

Symbol	Parameter	Test conditions	Min.	Typ.	Max.	Unit
$t_{PLH}$ , $t_{PHL}$	Propagation Delay	$V_{CC} = 3V$ to $3.6V$		0.25		ns
$t_{PZH}$ , $t_{PZL}$	Line Enable Time, SEL to x to x0 or x to x1, <a href="#">Note:4</a>	$V_{CC} = 3V$ to $3.6V$	0.5	6.5	9	ns
$t_{PHZ}$ , $t_{PLZ}$	Line Disable Time, SEL to x to x0 or x to x1, <a href="#">Note:4</a>	$V_{CC} = 3V$ to $3.6V$	0.5	6.5	8.5	ns
$t_{SK(0)}$	Output skew between center port to any other port	$V_{CC} = 3V$ to $3.6V$		0.1	0.2	ns
$t_{SK(P)}$	Skew between opposite transition of the same output ( $t_{PHL} - t_{PLH}$ )	$V_{CC} = 3V$ to $3.6V$		0.1	0.2	ns
$t_{ON}$	Propagation Delay	$V_{CC} = 3V$ to $3.6V$			50	ns
$t_{OFF}$	Propagation Delay	$V_{CC} = 3V$ to $3.6V$			30	ns

Note: 4.  $x = Data0+$ ,  $Data0-$ ,  $Data1+$ ,  $Data1-$ ,  $Data2+$ ,  $Data2-$ ,  $Clock+$ ,  $Clock-$ .

$X0 = A0+$ ,  $A0-$ ,  $A1+$ ,  $A1-$ ,  $A2+$ ,  $A2-$ ,  $AClock+$ ,  $AClock-$

$X1 = B0+$ ,  $B0-$ ,  $B1+$ ,  $B1-$ ,  $B2+$ ,  $B2-$ ,  $BClock+$ ,  $BClock-$

Note: Valid for Ambient Operating Temperature:  $T_A = -40$  to  $85^\circ C$ ;  $V_{CC} = 3.3V \pm 10\%$  (except where noted).

### 4.1 Timing characteristics

Figure 4. Enable and disable timings

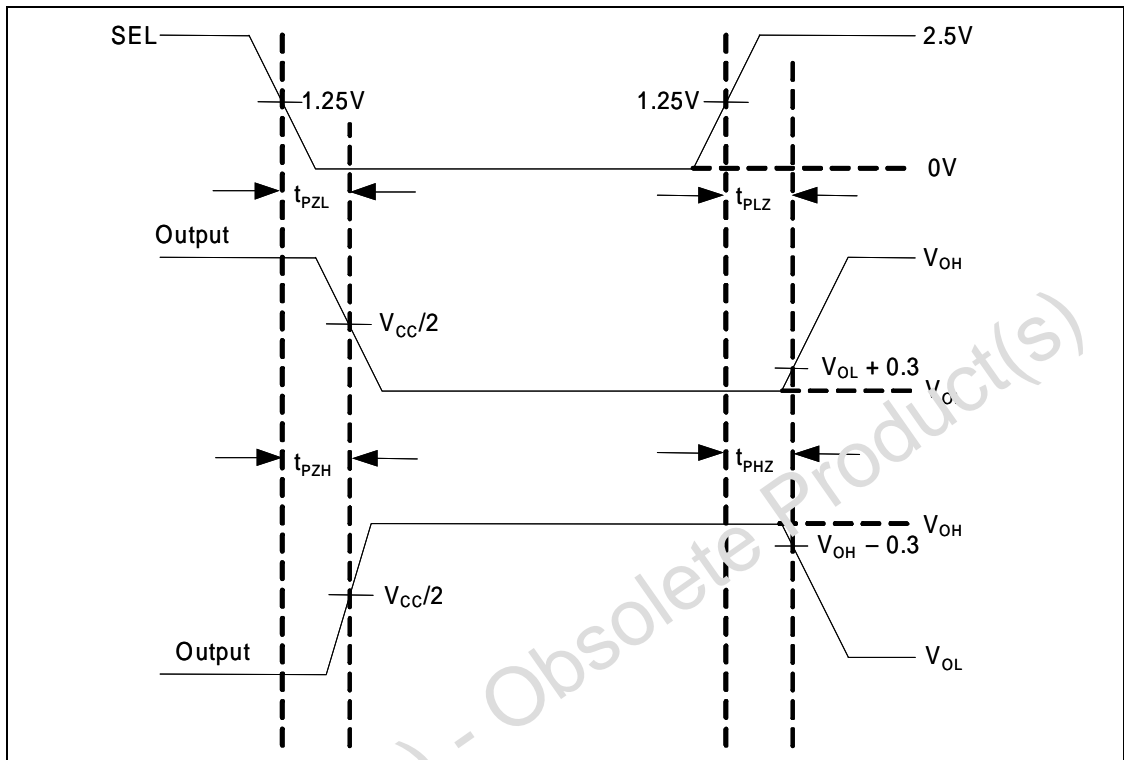
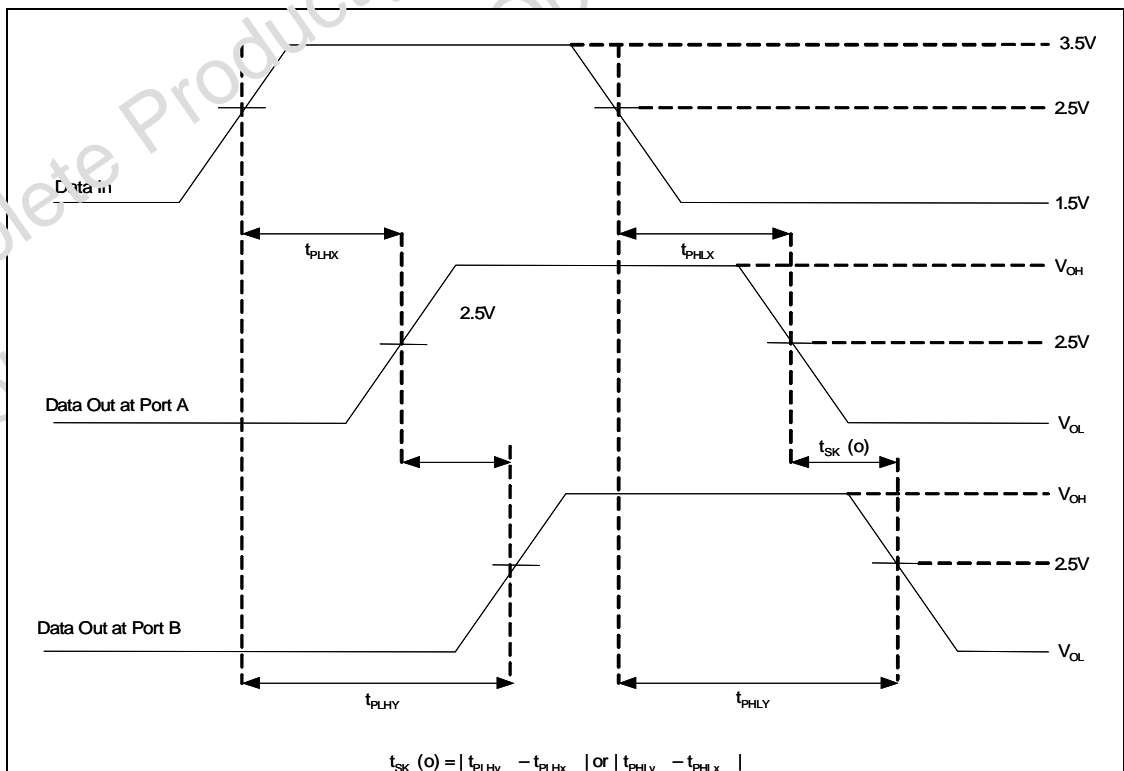

Figure 5. Output skew



$$t_{sk}(0) = |t_{pLHY} - t_{pLHX}| \text{ or } |t_{pHLY} - t_{pHLX}|$$

Figure 6. Propagation delay timings

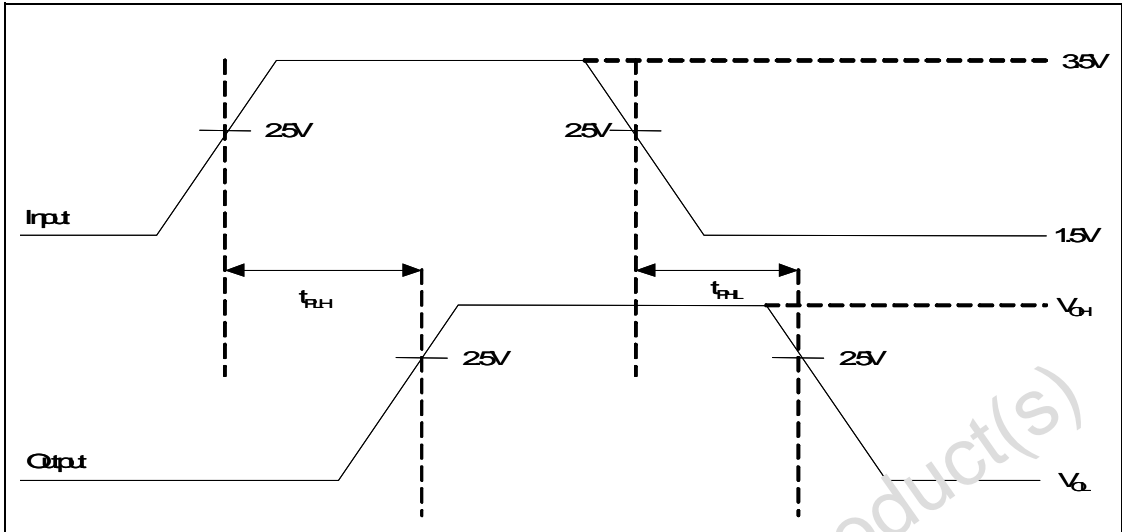
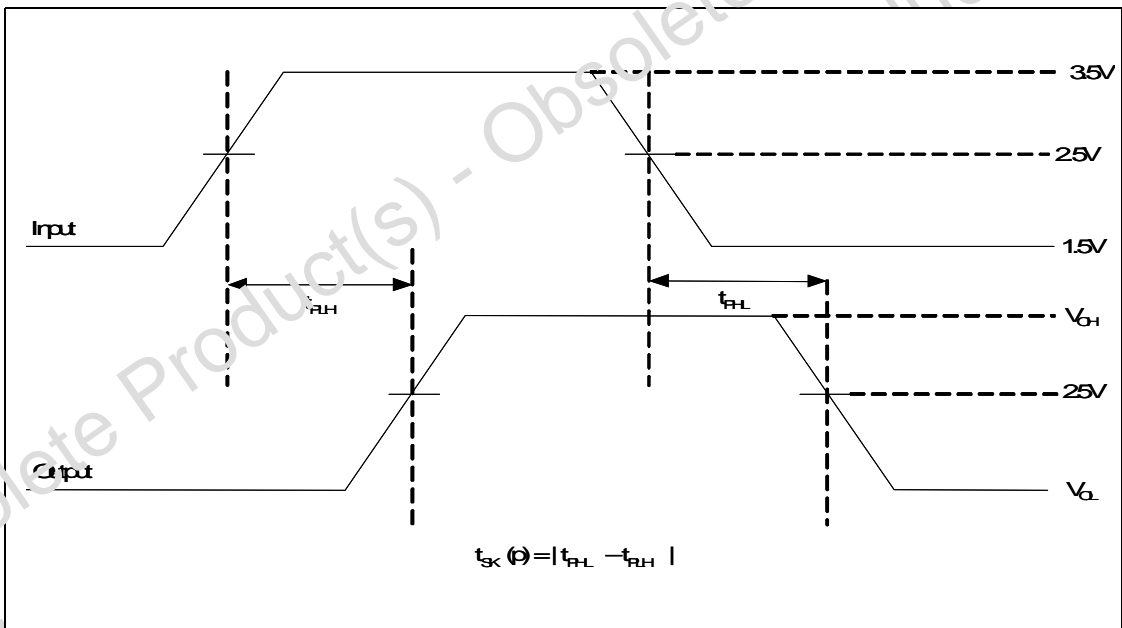

Figure 7. Pulse skew



## 5 ESD performance

Table 10. ESD performance

Symbol	Parameter	Test conditions	Min.	Typ.	Max.	Unit
ESD	All IOs	Human Body Model (HBM)		±2		kV

Obsolete Product(s) - Obsolete Product(s)  
Obsolete Product(s) - Obsolete Product(s)

## 6 Package mechanical data

In order to meet environmental requirements, ST offers these devices in ECOPACK<sup>®</sup> packages. These packages have a Lead-free second level interconnect . The category of second Level Interconnect is marked on the package and on the inner box label, in compliance with JEDEC Standard JESD97. The maximum ratings related to soldering conditions are also marked on the inner box label. ECOPACK is an ST trademark. ECOPACK specifications are available at: [www.st.com](http://www.st.com).

Obsolete Product(s) - Obsolete Product(s)  
Obsolete Product(s) - Obsolete Product(s)

**TSSOP48 MECHANICAL DATA**

DIM.	mm			inch		
	MIN.	TYP.	MAX.	MIN.	TYP.	MAX.
A			1.1			0.433
A1	0.05	0.10	0.15	0.002	0.004	0.006
A2	0.85	0.9	0.95	0.335	0.354	0.374
b	0.17		0.27	0.0067		0.011
c	0.09		0.20	0.0035		0.0079
D	12.4	12.5	12.6	0.408	0.492	0.496
E	7.95	8.1	8.25	0.313	0.319	0.325
E1	6.0	6.1	6.2	0.236	0.240	0.244
e		0.5 BSC			0.0197 BSC	
K	0°	4°	8°	0°	4°	8°
L	0.50	0.60	0.70	0.020	0.024	0.028

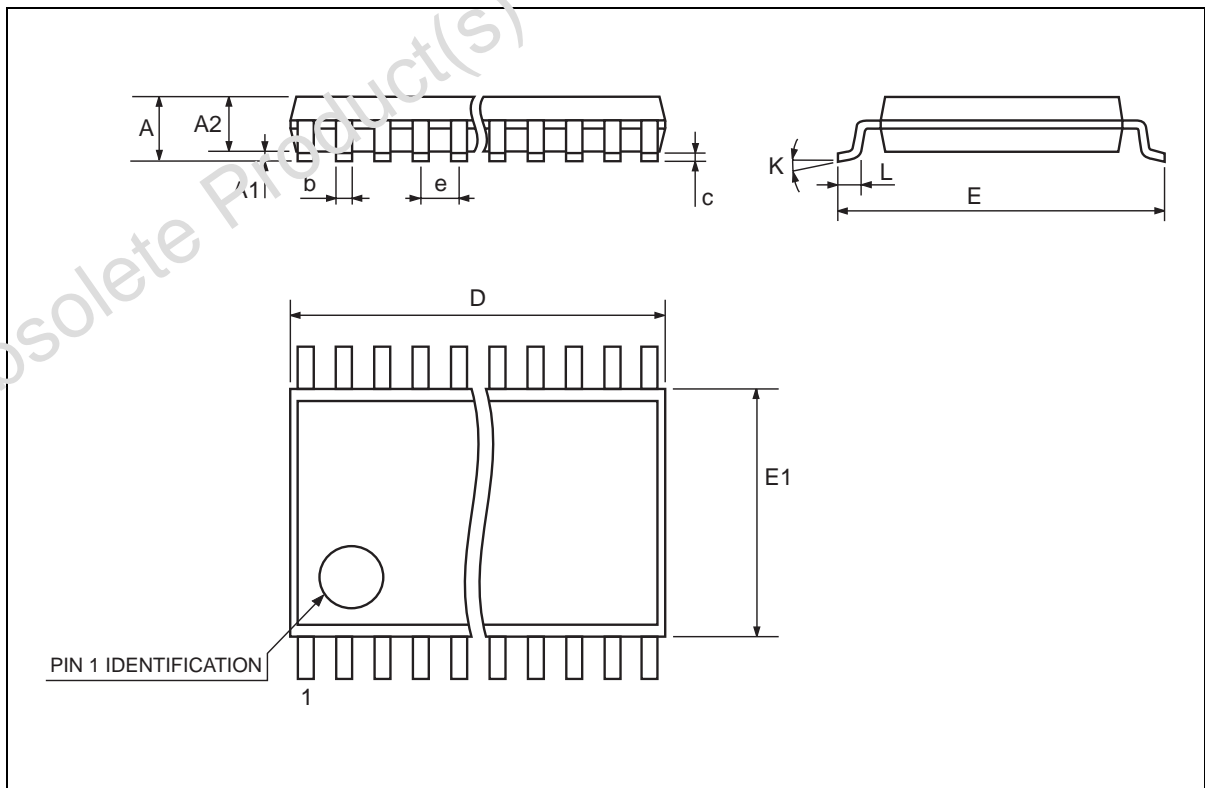

## 7 Revision history

**Table 11. Revision history**

Date	Revision	Change
09-Sep-2005	1	First issue
03-Jan-2006	2	Added the maximum data rate support. Added crosstalk, off-isolation values at higher frequencies.
21-Apr-2006	3	ESD table updated

Obsolete Product(s) - Obsolete Product(s)  
Obsolete Product(s) - Obsolete Product(s)

**Please Read Carefully:**

Information in this document is provided solely in connection with ST products. STMicroelectronics NV and its subsidiaries ("ST") reserve the right to make changes, corrections, modifications or improvements, to this document, and the products and services described herein at any time, without notice.

All ST products are sold pursuant to ST's terms and conditions of sale.

Purchasers are solely responsible for the choice, selection and use of the ST products and services described herein, and ST assumes no liability whatsoever relating to the choice, selection or use of the ST products and services described herein.

No license, express or implied, by estoppel or otherwise, to any intellectual property rights is granted under this document. If any part of this document refers to any third party products or services it shall not be deemed a license grant by ST for the use of such third party products or services, or any intellectual property contained therein or considered as a warranty covering the use in any manner whatsoever of such third party products or services or any intellectual property contained therein.

**UNLESS OTHERWISE SET FORTH IN ST'S TERMS AND CONDITIONS OF SALE ST DISCLAIMS ANY EXPRESS OR IMPLIED WARRANTY WITH RESPECT TO THE USE AND/OR SALE OF ST PRODUCTS INCLUDING WITHOUT LIMITATION IMPLIED WARRANTIES OF MERCHANTABILITY, FITNESS FOR A PARTICULAR PURPOSE (AND THEIR EQUIVALENTS UNDER THE LAWS OF ANY JURISDICTION), OR INFRINGEMENT OF ANY PATENT, COPYRIGHT OR OTHER INTELLECTUAL PROPERTY RIGHT.**

**UNLESS EXPRESSLY APPROVED IN WRITING BY AN AUTHORIZED REPRESENTATIVE OF ST, ST PRODUCTS ARE NOT DESIGNED, AUTHORIZED OR WARRANTED FOR USE IN MILITARY, AIR CRAFT, SPACE, LIFE SAVING, OR LIFE SUSTAINING APPLICATIONS, NOR IN PRODUCTS OR SYSTEMS, WHERE FAILURE OR MALFUNCTION MAY RESULT IN PERSONAL INJURY, DEATH, OR SEVERE PROPERTY OR ENVIRONMENTAL DAMAGE.**

Resale of ST products with provisions different from the statements and/or technical features set forth in this document shall immediately void any warranty granted by ST for the ST product or service described herein and shall not create or extend in any manner whatsoever, any liability of ST.

ST and the ST logo are trademarks or registered trademarks of ST in various countries.

Information in this document supersedes and replaces all information previously supplied.

The ST logo is a registered trademark of STMicroelectronics. All other names are the property of their respective owners.

© 2006 STMicroelectronics - All rights reserved

STMicroelectronics group of companies

Australia - Belgium - Brazil - Canada - China - Czech Republic - Finland - France - Germany - Hong Kong - India - Israel - Italy - Japan - Malaysia - Malta - Morocco - Singapore - Spain - Sweden - Switzerland - United Kingdom - United States of America

[www.st.com](http://www.st.com)

## Looking for pricing, stock, or lifecycle information?

Click below to explore more details on WIN SOURCE:

- ⊖ [View STHDMI001ATTR](#) on WIN SOURCE
- ⊖ [STMicroelectronics](#) Information

## Optimize Your Supply Chain with WIN SOURCE Solutions

- ✓ Global Sourcing Solution
- ✓ Obsolete Management
- ✓ Cost Control Management
- ✓ Shortage Management
- ✓ Alternative Solution
- ✓ Excess Inventory Management