



THE DATASHEET OF STGY40NC60VD





STGY40NC60VD

N-channel 600V - 50A - Max247
Very fast PowerMESH™ IGBT

Features

| Type | V _{CES} | V _{CE(sat)} (max)@25°C | I _c @100°C |
|--------------|------------------|------------------------------------|--------------------------|
| STGY40NC60VD | 600V | < 2.5V | 50A |

- High current capability
- High frequency operation up to 50kHz
- Low C_{RES} / C_{IES} ratio (no cross-conduction susceptibility)
- Very soft ultra fast recovery antiparallel diode

Description

Using the latest high voltage technology based on a patented strip layout, STMicroelectronics has designed an advanced family of IGBTs, the PowerMESH™ IGBTs, with outstanding performances. The suffix “V” identifies a family optimized for very high frequency applications.

Applications

- High frequency inverters, UPS
- SMPS and PFC in both hard switch and resonant topologies
- Motor drivers

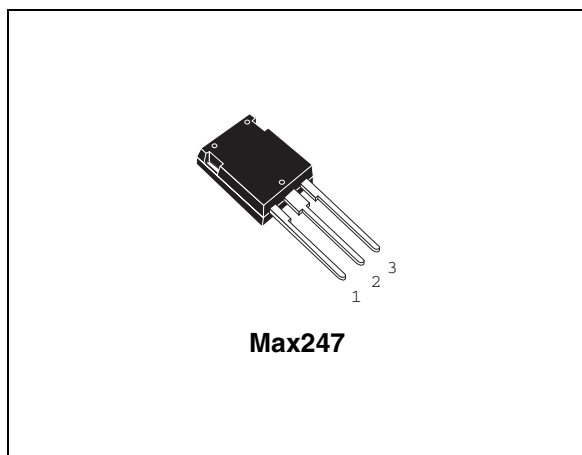

Figure 1. Internal schematic diagram

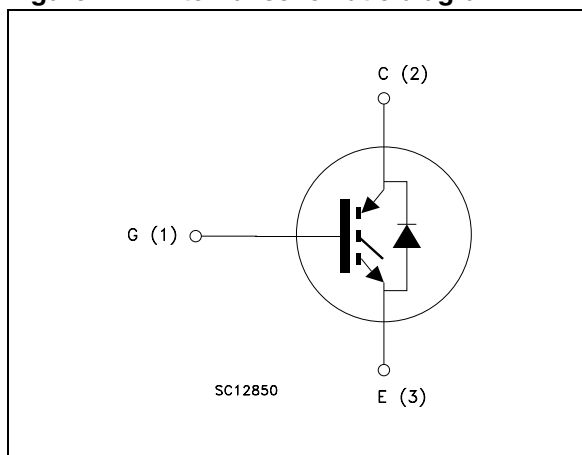

Table 1. Device summary

| Order code | Marking | Package | Packaging |
|--------------|------------|---------|-----------|
| STGY40NC60VD | GY40NC60VD | Max247 | Tube |

Contents

| | | |
|----------|---|-----------|
| 1 | Electrical ratings | 3 |
| 2 | Electrical characteristics | 4 |
| | 2.1 Electrical characteristics (curves) | 7 |
| 3 | Test circuit | 10 |
| 4 | Package mechanical data | 11 |
| 5 | Revision history | 13 |

1 Electrical ratings

Table 1. Absolute maximum ratings

| Symbol | Parameter | Value | Unit |
|----------------|---|------------|------------------|
| V_{CES} | Collector-emitter voltage ($V_{GS} = 0$) | 600 | V |
| $I_C^{(1)}$ | Collector current (continuous) at $T_C = 25^\circ\text{C}$ | 80 | A |
| $I_C^{(1)}$ | Collector current (continuous) at $T_C = 100^\circ\text{C}$ | 50 | A |
| $I_{CL}^{(2)}$ | Turn-off SOA minimum current | 200 | A |
| I_F | Diode RMS forward current at $T_C = 25^\circ\text{C}$ | 30 | A |
| V_{GE} | Gate-emitter voltage | ± 20 | V |
| P_{TOT} | Total dissipation at $T_C = 25^\circ\text{C}$ | 260 | W |
| T_j | Operating junction temperature | -55 to 150 | $^\circ\text{C}$ |

1. Calculated according to the iterative formula:

$$I_C(T_C) = \frac{T_{JMAX} - T_C}{R_{THJ-C} \times V_{CESAT(MAX)}(T_C, I_C)}$$

2. Pulse width limited by max junction temperature

Table 2. Thermal resistance

| Symbol | Parameter | Value | Unit |
|----------------|---|-------|---------------------------|
| $R_{thj-case}$ | Thermal resistance junction-case max IGBT | 0.48 | $^\circ\text{C}/\text{W}$ |
| $R_{thj-case}$ | Thermal resistance junction-case max diode | 1.5 | $^\circ\text{C}/\text{W}$ |
| $R_{thj-amb}$ | Thermal resistance junction-ambient max | 50 | $^\circ\text{C}/\text{W}$ |
| T_L | Maximum lead temperature for soldering purpose (1.6mm from case, for 10 sec) typ. | 300 | $^\circ\text{C}$ |

2 Electrical characteristics

($T_{CASE}=25^{\circ}C$ unless otherwise specified)

Table 3. Static

| Symbol | Parameter | Test conditions | Min. | Typ. | Max. | Unit |
|---------------|---|---|------|------------|-----------|---------------|
| $V_{BR(CES)}$ | Collector-emitter breakdown voltage | $I_C = 1mA, V_{GE} = 0$ | 600 | | | V |
| $V_{CE(sat)}$ | Collector-emitter saturation voltage | $V_{GE} = 15V, I_C = 40A$ $V_{GE} = 15V, I_C = 40A, T_C = 125^{\circ}C$ | | 1.9 1.7 | 2.5 | V V |
| $V_{GE(th)}$ | Gate threshold voltage | $V_{CE} = V_{GE}, I_C = 250\mu A$ | 3.75 | | 5.75 | V |
| I_{CES} | Collector cut-off current ($V_{GE} = 0$) | $V_{CE} = \text{Max rating}, T_C = 25^{\circ}C$ $V_{CE} = \text{Max rating}, T_C = 125^{\circ}C$ | | | 10 1 | μA mA |
| I_{GES} | Gate-emitter leakage current ($V_{CE} = 0$) | $V_{GE} = \pm 20V, V_{CE} = 0$ | | | ± 100 | nA |
| g_{fs} | Forward transconductance | $V_{CE} = 15V, I_C = 20A$ | | 20 | | S |

Table 4. Dynamic

| Symbol | Parameter | Test conditions | Min. | Typ. | Max. | Unit |
|-----------|------------------------------|---|------|------|------|------|
| C_{ies} | Input capacitance | $V_{CE} = 25V, f = 1MHz,$ $V_{GE} = 0$ | | 4550 | | pF |
| C_{oes} | Output capacitance | | | 350 | | pF |
| C_{res} | Reverse transfer capacitance | | | 105 | | pF |
| Q_g | Total gate charge | $V_{CE} = 390V, I_C = 40A,$ | | 214 | | nC |
| Q_{ge} | Gate-emitter charge | $V_{GE} = 15V,$ | | 30 | | nC |
| Q_{gc} | Gate-collector charge | Figure 17 | | 96 | | nC |

Table 5. Switching on/off (inductive load)

| Symbol | Parameter | Test conditions | Min. | Typ. | Max. | Unit |
|---|---|--|------|------------------|------|------------------------|
| $t_{d(on)}$ t_r $(di/dt)_{on}$ | Turn-on delay time Current rise time Turn-on current slope | $V_{CC} = 390V, I_C = 40A$ $R_G = 3.3\Omega, V_{GE} = 15V,$ <i>Figure 18, Figure 16</i> | | 43 17 2060 | | ns ns A/ μ s |
| $t_{d(on)}$ t_r $(di/dt)_{on}$ | Turn-on delay time Current rise time Turn-on current slope | $V_{CC} = 390V, I_C = 40A$ $R_G = 3.3\Omega, V_{GE} = 15V,$ $T_J = 125^\circ C$ <i>Figure 18, Figure 16</i> | | 42 19 1900 | | ns ns A/ μ s |
| $t_{r(Voff)}$ $t_{d(Voff)}$ t_f | Off voltage rise time Turn-off delay time Current fall time | $V_{CC} = 390V, I_C = 40A$ $R_G = 3.3\Omega, V_{GE} = 15V,$ <i>Figure 18, Figure 16</i> | | 25 140 45 | | ns ns ns |
| $t_{r(Voff)}$ $t_{d(Voff)}$ t_f | Off voltage rise time Turn-off delay time Current fall time | $V_{CC} = 390V, I_C = 40A$ $R_G = 3.3\Omega, V_{GE} = 15V,$ $T_J = 125^\circ C$ <i>Figure 18, Figure 16</i> | | 60 170 77 | | ns ns ns |

Table 6. Switching energy (inductive load)

| Symbol | Parameter | Test conditions | Min. | Typ. | Max. | Unit |
|---|---|---|------|---------------------|--------------------|-------------------------------|
| E_{on} $E_{off}^{(1)}$ E_{ts} | Turn-on switching losses Turn-off switching losses Total switching losses | $V_{CC} = 390V, I_C = 40A$ $R_G = 3.3\Omega, V_{GE} = 15V,$ <i>Figure 16</i> | | 330 720 1050 | 450 970 1420 | μ J μ J μ J |
| E_{on} $E_{off}^{(1)}$ E_{ts} | Turn-on switching losses Turn-off switching losses Total switching losses | $V_{CC} = 390V, I_C = 40A$ $R_G = 3.3\Omega, V_{GE} = 15V,$ $T_J = 125^\circ C$ <i>Figure 16</i> | | 640 1400 2040 | | μ J μ J μ J |

1. Turn-off losses include also the tail of the collector current

Table 7. Collector-emitter diode

| Symbol | Parameter | Test conditions | Min. | Typ. | Max. | Unit |
|-----------|--------------------------|--|------|------|------|------|
| V_f | Forward on-voltage | $I_f = 20A$ | | 1.5 | 2.2 | V |
| | | $I_f = 20A, T_j = 125^\circ C$ | | 1 | | V |
| t_{rr} | Reverse recovery time | $I_f = 20A, V_R = 40V,$ $T_j = 25^\circ C, di/dt = 100 A/\mu s$ | | 44 | | ns |
| Q_{rr} | Reverse recovery charge | $T_j = 25^\circ C, di/dt = 100 A/\mu s$ | | 66 | | nC |
| I_{rrm} | Reverse recovery current | Figure 19 | | 3 | | A |
| t_{rr} | Reverse recovery time | $I_f = 40A, V_R = 50V,$ $T_j = 125^\circ C, di/dt = 100A/\mu s$ | | 88 | | ns |
| Q_{rr} | Reverse recovery charge | $T_j = 125^\circ C, di/dt = 100A/\mu s$ | | 237 | | nC |
| I_{rrm} | Reverse recovery current | Figure 19 | | 5.4 | | A |

2.1 Electrical characteristics (curves)

Figure 1. Output characteristics

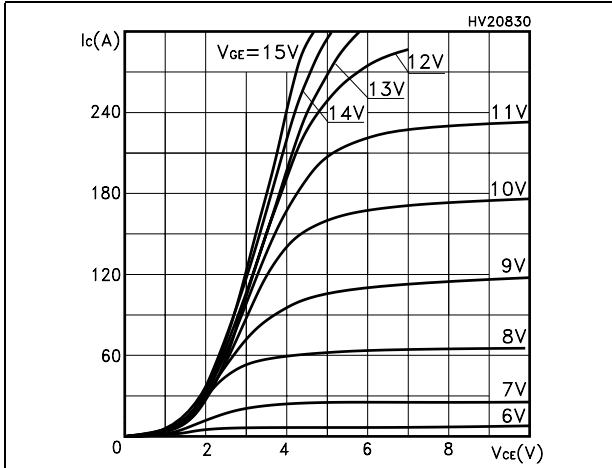

Figure 2. Transfer characteristics

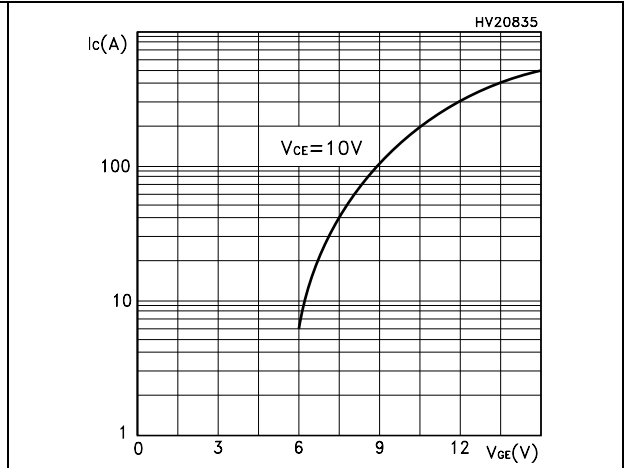

Figure 3. Transconductance

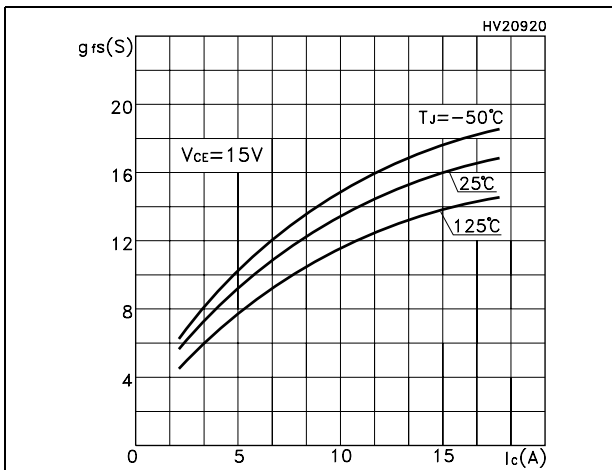

Figure 4. Collector-emitter on voltage vs temperature

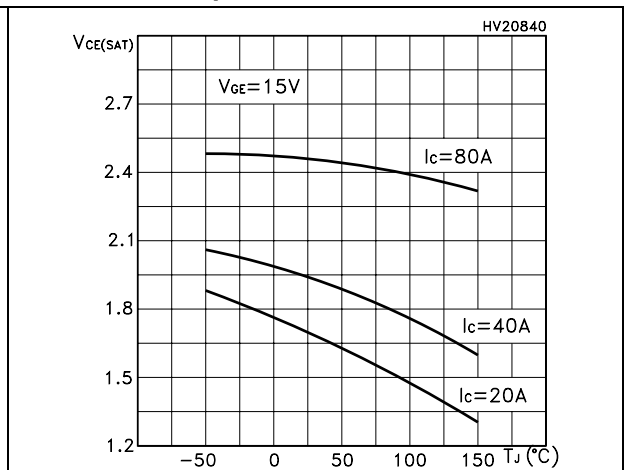

Figure 5. Gate charge vs gate-source voltage Figure 6. Capacitance variations

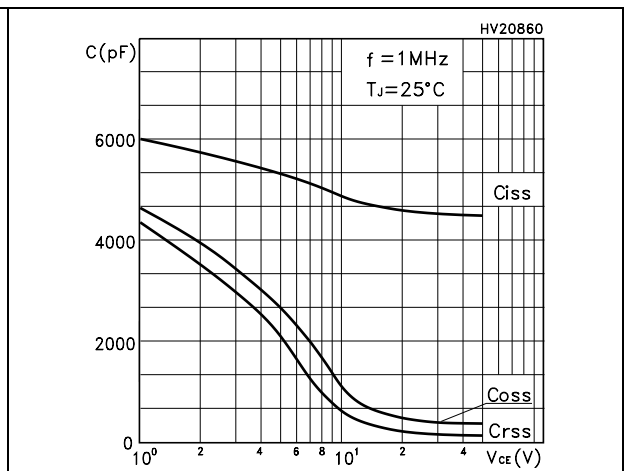
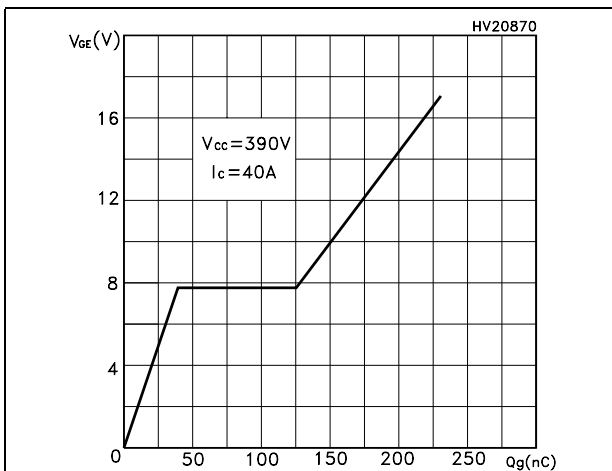

Figure 7. Normalized gate threshold voltage vs temperature

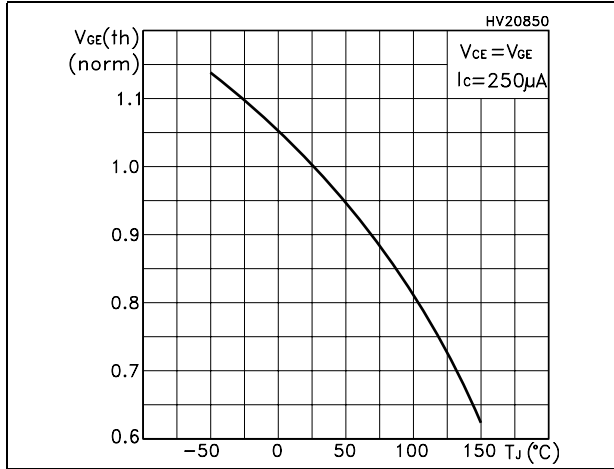

Figure 8. Collector-emitter on voltage vs collector current

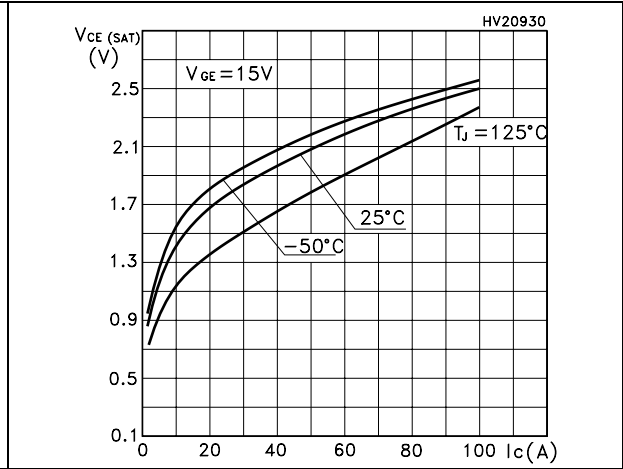

Figure 9. Normalized breakdown voltage vs temperature

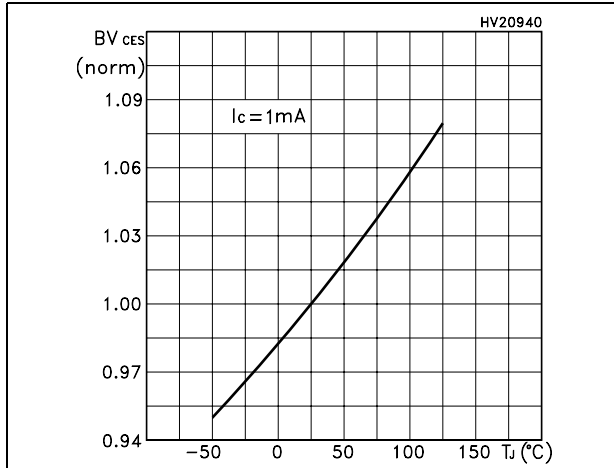

Figure 10. Switching losses vs temperature

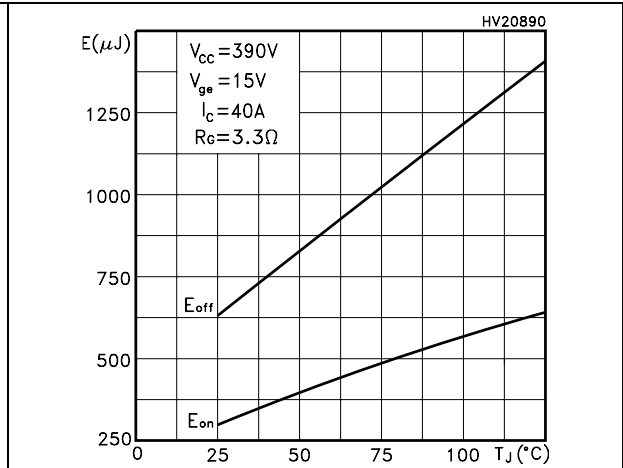

Figure 11. Switching losses vs gate resistance

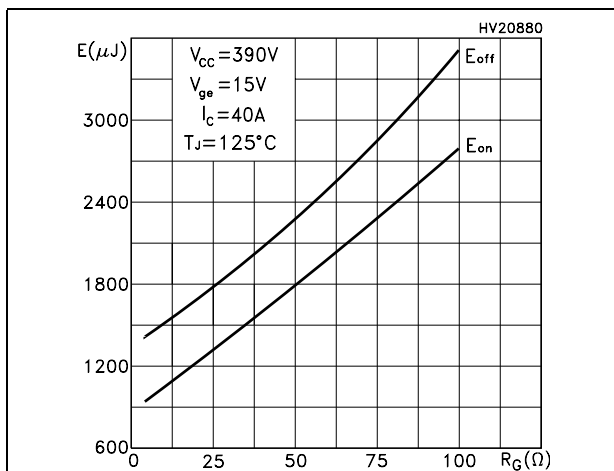

Figure 12. Switching losses vs collector current

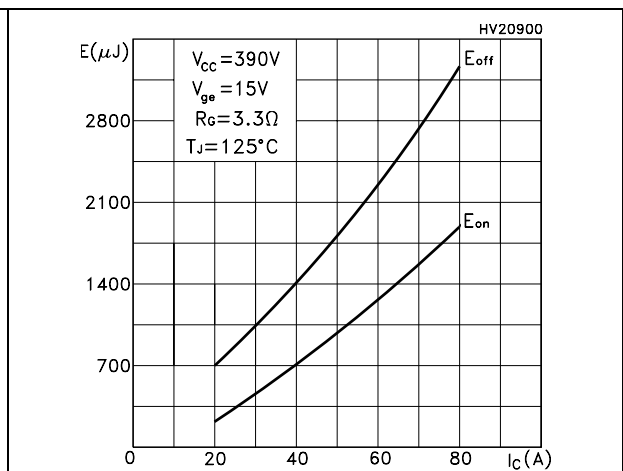

Figure 13. Turn-off SOA

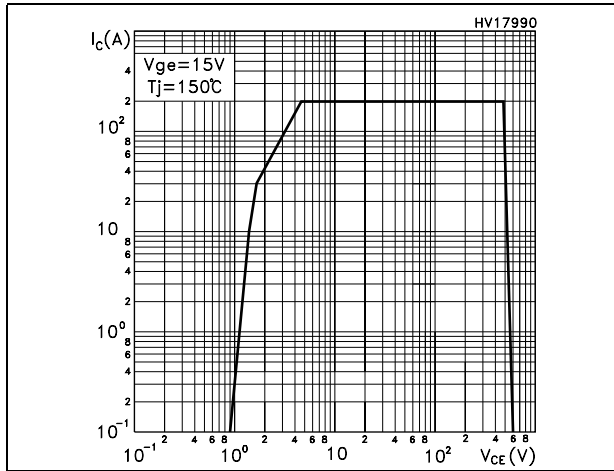

Figure 14. Thermal impedance

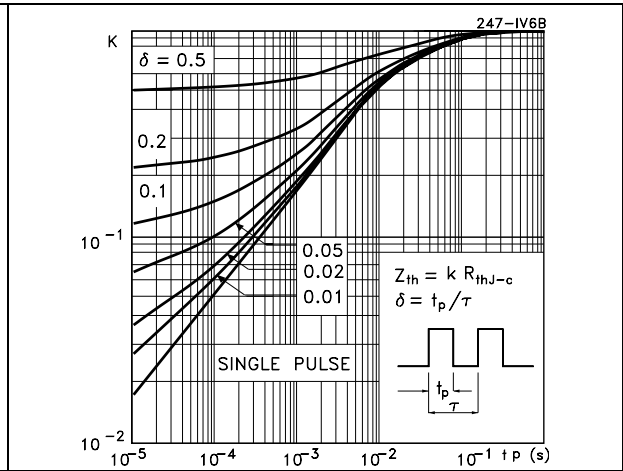
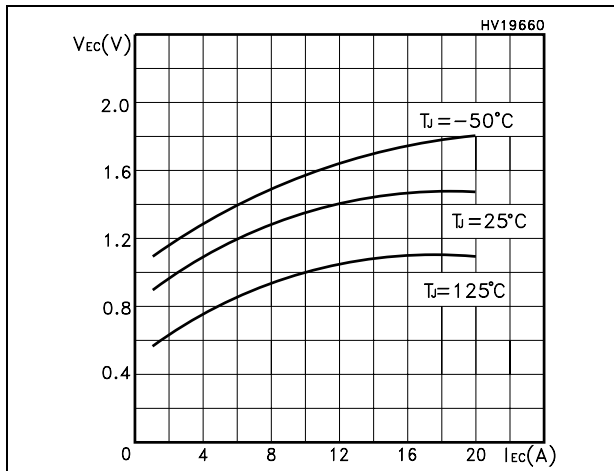

Figure 15. Emitter-collector diode characteristics



3 Test circuit

Figure 16. Test circuit for inductive load switching

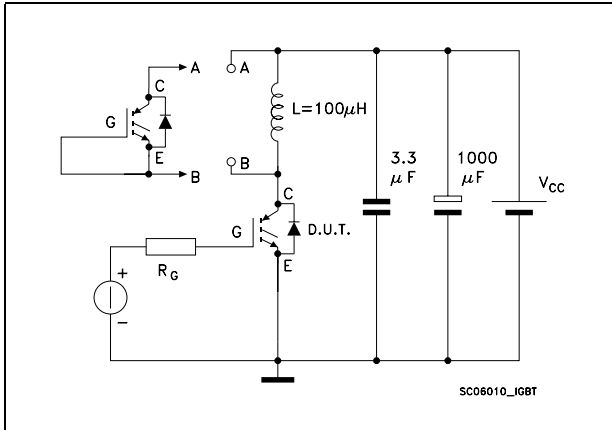

Figure 17. Gate charge test circuit

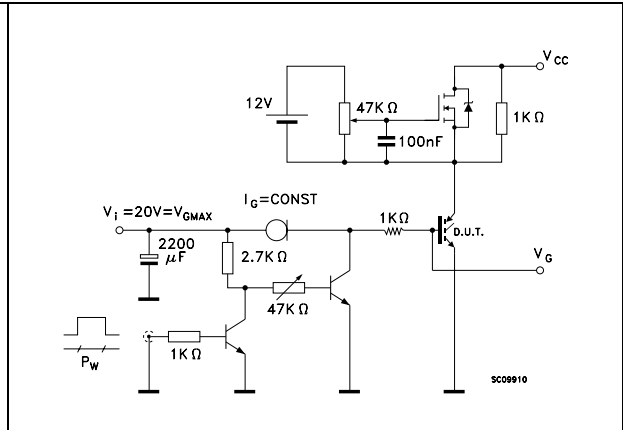

Figure 18. Switching waveform

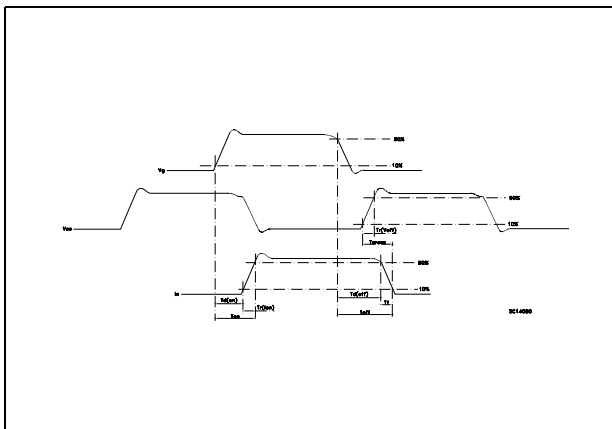
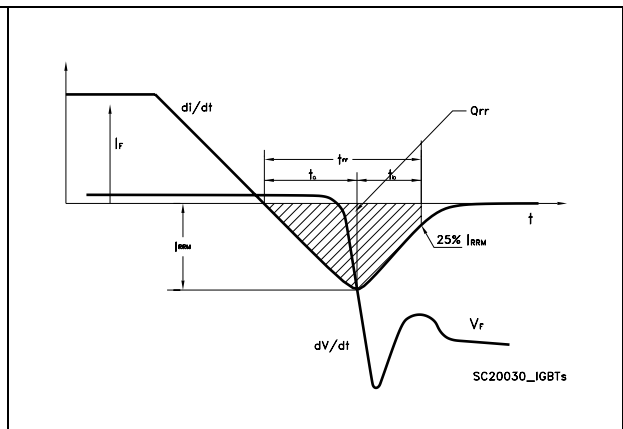

Figure 19. Diode recovery time waveform



4 Package mechanical data

In order to meet environmental requirements, ST offers these devices in ECOPACK® packages. These packages have a Lead-free second level interconnect. The category of second level interconnect is marked on the package and on the inner box label, in compliance with JEDEC Standard JESD97. The maximum ratings related to soldering conditions are also marked on the inner box label. ECOPACK is an ST trademark. ECOPACK specifications are available at: www.st.com

Max247 MECHANICAL DATA

| DIM. | mm | | | inch | | |
|------|-------|------|-------|------|------|------|
| | MIN. | TYP. | MAX. | MIN. | TYP. | MAX. |
| A | 4.70 | | 5.30 | | | |
| A1 | 2.20 | | 2.60 | | | |
| b | 1.00 | | 1.40 | | | |
| b1 | 2.00 | | 2.40 | | | |
| b2 | 3.00 | | 3.40 | | | |
| c | 0.40 | | 0.80 | | | |
| D | 19.70 | | 20.30 | | | |
| e | 5.35 | | 5.55 | | | |
| E | 15.30 | | 15.90 | | | |
| L | 14.20 | | 15.20 | | | |
| L1 | 3.70 | | 4.30 | | | |

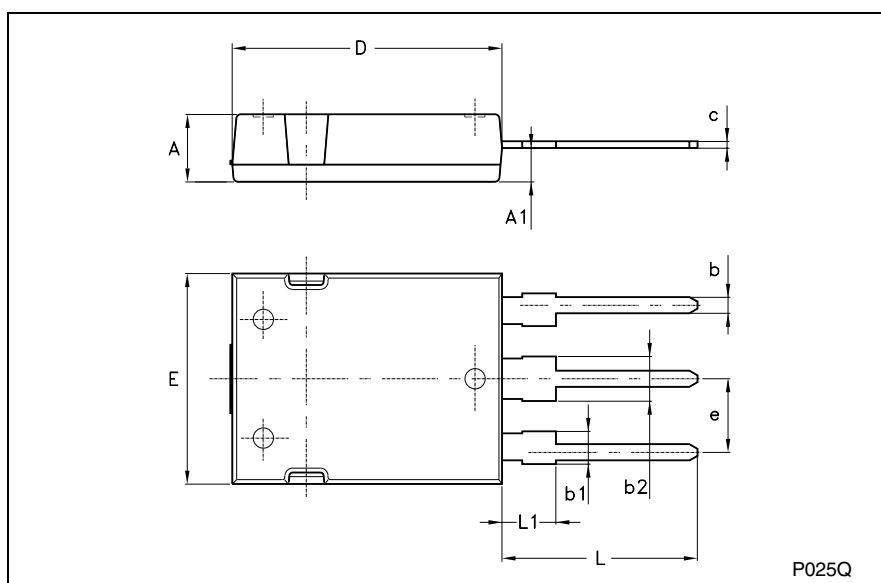

5 Revision history

Table 8. Revision history

| Date | Revision | Changes |
|-------------|----------|--|
| 07-Jun-2004 | 7 | Initial electronic version. |
| 14-Jul-2004 | 8 | <i>Figure 15</i> has been update |
| 13-Jul-2007 | 9 | The document has been reformatted, corrected error on <i>Table 4</i> |

Please Read Carefully:

Information in this document is provided solely in connection with ST products. STMicroelectronics NV and its subsidiaries ("ST") reserve the right to make changes, corrections, modifications or improvements, to this document, and the products and services described herein at any time, without notice.

All ST products are sold pursuant to ST's terms and conditions of sale.

Purchasers are solely responsible for the choice, selection and use of the ST products and services described herein, and ST assumes no liability whatsoever relating to the choice, selection or use of the ST products and services described herein.

No license, express or implied, by estoppel or otherwise, to any intellectual property rights is granted under this document. If any part of this document refers to any third party products or services it shall not be deemed a license grant by ST for the use of such third party products or services, or any intellectual property contained therein or considered as a warranty covering the use in any manner whatsoever of such third party products or services or any intellectual property contained therein.

UNLESS OTHERWISE SET FORTH IN ST'S TERMS AND CONDITIONS OF SALE ST DISCLAIMS ANY EXPRESS OR IMPLIED WARRANTY WITH RESPECT TO THE USE AND/OR SALE OF ST PRODUCTS INCLUDING WITHOUT LIMITATION IMPLIED WARRANTIES OF MERCHANTABILITY, FITNESS FOR A PARTICULAR PURPOSE (AND THEIR EQUIVALENTS UNDER THE LAWS OF ANY JURISDICTION), OR INFRINGEMENT OF ANY PATENT, COPYRIGHT OR OTHER INTELLECTUAL PROPERTY RIGHT.

UNLESS EXPRESSLY APPROVED IN WRITING BY AN AUTHORIZED ST REPRESENTATIVE, ST PRODUCTS ARE NOT RECOMMENDED, AUTHORIZED OR WARRANTED FOR USE IN MILITARY, AIR CRAFT, SPACE, LIFE SAVING, OR LIFE SUSTAINING APPLICATIONS, NOR IN PRODUCTS OR SYSTEMS WHERE FAILURE OR MALFUNCTION MAY RESULT IN PERSONAL INJURY, DEATH, OR SEVERE PROPERTY OR ENVIRONMENTAL DAMAGE. ST PRODUCTS WHICH ARE NOT SPECIFIED AS "AUTOMOTIVE GRADE" MAY ONLY BE USED IN AUTOMOTIVE APPLICATIONS AT USER'S OWN RISK.

Resale of ST products with provisions different from the statements and/or technical features set forth in this document shall immediately void any warranty granted by ST for the ST product or service described herein and shall not create or extend in any manner whatsoever, any liability of ST.

ST and the ST logo are trademarks or registered trademarks of ST in various countries.

Information in this document supersedes and replaces all information previously supplied.

The ST logo is a registered trademark of STMicroelectronics. All other names are the property of their respective owners.

© 2007 STMicroelectronics - All rights reserved

STMicroelectronics group of companies

Australia - Belgium - Brazil - Canada - China - Czech Republic - Finland - France - Germany - Hong Kong - India - Israel - Italy - Japan - Malaysia - Malta - Morocco - Singapore - Spain - Sweden - Switzerland - United Kingdom - United States of America

www.st.com

Looking for pricing, stock, or lifecycle information?

Click below to explore more details on WIN SOURCE:

- ⊖ [View STGY40NC60VD on WIN SOURCE](#)
- ⊖ [STMicroelectronics Information](#)

Optimize Your Supply Chain with WIN SOURCE Solutions

- ✓ Global Sourcing Solution
- ✓ Obsolete Management
- ✓ Cost Control Management
- ✓ Shortage Management
- ✓ Alternative Solution
- ✓ Excess Inventory Management