



THE DATASHEET OF STGF7NC60HD





STGB7NC60HD, STGF7NC60HD, STGP7NC60HD

N-channel 14 A, 600 V, very fast IGBT with Ultrafast diode

Datasheet – production data

Features

- Low on-voltage drop ($V_{CE(sat)}$)
- Off losses include tail current
- Losses include diode recovery energy
- High frequency operation up to 70 kHz
- Very soft ultra fast recovery anti parallel diode

Applications

- High frequency inverters
- SMPS and PFC in both hard switch and resonant topologies
- Motor drivers

Description

These devices are very fast IGBT developed using advanced PowerMESH™ technology. This process guarantees an excellent trade-off between switching performance and low on-state behavior. These devices are well-suited for resonant or soft-switching applications.

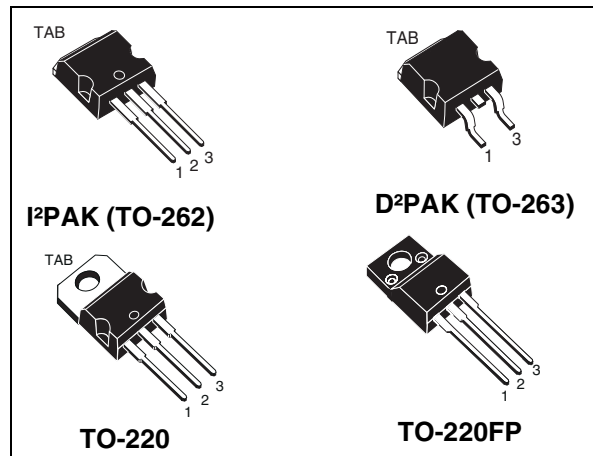

Figure 1. Internal schematic diagram

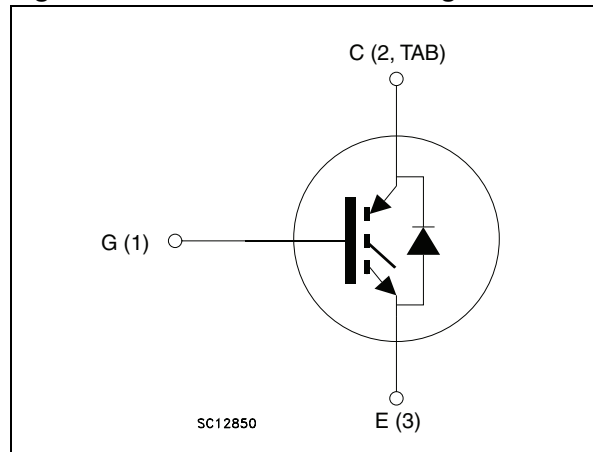

Table 1. Device summary

| Order codes | Markings | Packages | Packaging |
|---------------|-----------|----------------|---------------|
| STGB7NC60HD-1 | GB7NC60HD | I²PAK (TO-262) | Tube |
| STGB7NC60HDT4 | | D²PAK (TO-263) | Tape and reel |
| STGF7NC60HD | GF7NC60HD | TO-220FP | Tube |
| STGP7NC60HD | GP7NC60HD | TO-220 | Tube |

Contents

| | | |
|----------|---|-----------|
| 1 | Electrical ratings | 3 |
| 2 | Electrical characteristics | 4 |
| 2.1 | Electrical characteristics (curves) | 6 |
| 2.2 | Operating frequency | 9 |
| 3 | Test circuits | 10 |
| 4 | Package mechanical data | 11 |
| 5 | Packaging mechanical data | 19 |
| 6 | Revision history | 21 |

1 Electrical ratings

Table 2. Absolute maximum ratings

| Symbol | Parameter | Value | | Unit |
|--------------------------------|--|--|----------|------|
| | | I ² PAK, D ² PAK, TO-220 | TO-220FP | |
| V _{CES} | Collector-emitter voltage (V _{GS} = 0) | 600 | | V |
| V _{ECR} | Emitter-collector voltage | 20 | | V |
| V _{GE} | Gate-emitter voltage | ±20 | | V |
| I _C | Collector current (continuous) at T _C = 25 °C ⁽¹⁾ | 25 | 10 | A |
| I _C | Collector current (continuous) at T _C = 100 °C ⁽¹⁾ | 14 | 6 | A |
| I _{CM} ⁽²⁾ | Collector current (pulsed) | 50 | | A |
| I _F | Diode RMS forward current at T _C = 25 °C | 20 | | A |
| P _{TOT} | Total dissipation at T _C = 25 °C | 80 | 25 | W |
| | Derating factor | 0.64 | 0.20 | W/°C |
| V _{ISO} | Insulation withstand voltage A.C. (t = 1 sec; T _C = 25 °C) | -- | 2500 | V |
| T _{stg} | Storage temperature | – 55 to 150 | | °C |
| T _j | Operating junction temperature | | | |

1. Calculated according to the iterative formula:

$$I_C(T_C) = \frac{T_{j(max)} - T_C}{R_{thj-c} \times V_{CE(sat)(max)}(T_{j(max)}, I_C(T_C))}$$

2. Pulse width limited by maximum junction temperature and turn-off within RBSOA.

Table 3. Thermal data

| Symbol | Parameter | Value | | Unit |
|-------------------|-------------------------------------|--|----------|------|
| | | I ² PAK, D ² PAK, TO-220 | TO-220FP | |
| R _{thJC} | Thermal resistance junction-case | 1.56 | 5.0 | °C/W |
| R _{thJA} | Thermal resistance junction-ambient | 62.5 | | °C/W |

2 Electrical characteristics

$T_{CASE} = 25^{\circ}\text{C}$ unless otherwise specified.

Table 4. Electrical characteristics

| Symbol | Parameter | Test conditions | Min. | Typ. | Max. | Unit |
|---------------|---|---|------|-------------|-----------|---------------------|
| $V_{(BR)CES}$ | Collector-emitter breakdown voltage | $I_C = 1 \text{ mA}, V_{GE} = 0$ | 600 | | | V |
| I_{CES} | Collector cut-off current ($V_{GE} = 0$) | $V_{CE} = 600 \text{ V}$ $V_{CE} = 600 \text{ V}, T_C = 125^{\circ}\text{C}$ | | | 10 1 | μA mA |
| I_{GES} | Gate-emitter leakage current ($V_{CE} = 0$) | $V_{GE} = \pm 20 \text{ V}$ | | | ± 100 | nA |
| $V_{GE(th)}$ | Gate threshold voltage | $V_{CE} = V_{GE}, I_C = 250 \mu\text{A}$ | 3.75 | | 5.75 | V |
| $V_{CE(sat)}$ | Collector-emitter saturation voltage | $V_{GE} = 15 \text{ V}, I_C = 7 \text{ A}$ $V_{GE} = 15 \text{ V}, I_C = 7 \text{ A}, T_C = 125^{\circ}\text{C}$ | | 1.85 1.7 | 2.5 | V V |

Table 5. Dynamic

| Symbol | Parameter | Test conditions | Min. | Typ. | Max. | Unit |
|----------------|------------------------------|--|------|------|------|------|
| $g_{fs}^{(1)}$ | Forward transconductance | $V_{CE} = 15 \text{ V}, I_C = 7 \text{ A}$ | | 4.30 | | S |
| C_{ies} | Input capacitance | $V_{CE} = 25 \text{ V}, f = 1 \text{ MHz},$ $V_{GE} = 0$ | | 720 | | pF |
| C_{oes} | Output capacitance | | | 81 | | pF |
| C_{res} | Reverse transfer capacitance | | | 17 | | pF |
| Q_g | Total gate charge | $V_{CE} = 390 \text{ V}, I_C = 7 \text{ A},$ $V_{GE} = 15 \text{ V}$ | | 35 | 48 | nC |
| Q_{ge} | Gate-emitter charge | | | 7 | | nC |
| Q_{gc} | Gate-collector charge | | | 16 | | nC |
| I_{CL} | Turn-off SOA minimum current | $V_{clamp} = 480 \text{ V}, T_j = 150^{\circ}\text{C}$ $R_G = 10 \Omega, V_{GE} = 15 \text{ V}$ | 50 | | | A |

1. Pulsed: Pulse duration= 300 μs , duty cycle 1.5%

Table 6. Switching on

| Symbol | Parameter | Test conditions | Min. | Typ. | Max. | Unit |
|----------------|-----------------------|--|------|------|------|------------------|
| $t_{d(on)}$ | Turn-on delay time | $V_{CC} = 390 \text{ V}, I_C = 7 \text{ A}$ $R_G = 10 \Omega, V_{GE} = 15 \text{ V}$ (see Figure 21) | | 18.5 | | ns |
| t_r | Current rise time | | | 8.5 | | ns |
| $(di/dt)_{on}$ | Turn-on current slope | | | 1060 | | A/ μs |
| $t_{d(on)}$ | Turn-on delay time | $V_{CC} = 390 \text{ V}, I_C = 7 \text{ A}$ $R_G = 10 \Omega, V_{GE} = 15 \text{ V},$ $T_j = 125^{\circ}\text{C}$ (see Figure 21) | | 18.5 | | ns |
| t_r | Current rise time | | | 7 | | ns |
| $(di/dt)_{on}$ | Turn-on current slope | | | 1000 | | A/ μs |

Table 7. Switching off

| Symbol | Parameter | Test conditions | Min. | Typ. | Max. | Unit |
|----------------|-----------------------|--|------|------|------|------|
| $t_r(V_{off})$ | Off voltage rise time | $V_{CC} = 390\text{ V}$, $I_C = 7\text{ A}$, $R_G = 10\ \Omega$, $V_{GE} = 15\text{ V}$ | - | 27 | - | ns |
| $t_{d(off)}$ | Turn-off delay time | | | 72 | | ns |
| t_f | Current fall time | | | 60 | | ns |
| $t_r(V_{off})$ | Off voltage rise time | $V_{CC} = 390\text{ V}$, $I_C = 7\text{ A}$, $R_G = 10\ \Omega$, $V_{GE} = 15\text{ V}$, $T_j = 125\text{ }^\circ\text{C}$ | - | 56 | - | ns |
| $t_{d(off)}$ | Turn-off delay time | | | 116 | | ns |
| t_f | Current fall time | | | 105 | | ns |

Table 8. Switching energy

| Symbol | Parameter | Test conditions | Min. | Typ. | Max. | Unit |
|-----------------|--------------------------|--|------|------|------|---------------|
| $E_{on}^{(1)}$ | Turn-on switching losses | $V_{CC} = 390\text{ V}$, $I_C = 7\text{ A}$, $R_G = 10\ \Omega$, $V_{GE} = 15\text{ V}$, | - | 95 | 125 | μJ |
| $E_{off}^{(2)}$ | Turn-off switching loss | | | 115 | 150 | μJ |
| E_{ts} | Total switching loss | | | 210 | 275 | μJ |
| $E_{on}^{(1)}$ | Turn-on switching losses | $V_{CC} = 390\text{ V}$, $I_C = 7\text{ A}$, $R_G = 10\ \Omega$, $V_{GE} = 15\text{ V}$, $T_j = 125\text{ }^\circ\text{C}$ | - | 140 | | μJ |
| $E_{off}^{(2)}$ | Turn-off switching loss | | | 215 | | μJ |
| E_{ts} | Total switching loss | | | 355 | | μJ |

- E_{on} is the turn-on losses when a typical diode is used in the test circuit. If the IGBT is offered in a package with a co-pack diode, the co-pack diode is used as external diode. IGBTs and diode are at the same temperature (25°C and 125°C).
- Turn-off losses include also the tail of the collector current.

Table 9. Collector-emitter diode

| Symbol | Parameter | Test conditions | Min. | Typ. | Max. | Unit |
|-----------|------------------------------|--|------|------------|------|--------|
| V_f | Forward on-voltage | $I_f = 3.5\text{ A}$ $I_f = 3.5\text{ A}$, $T_j = 125\text{ }^\circ\text{C}$ | - | 1.3 1.1 | 1.9 | V V |
| t_{rr} | Reverse recovery time | $I_f = 7\text{ A}$, $V_R = 40\text{ V}$, $di/dt = 100\text{ A}/\mu\text{s}$ | | 37 | | ns |
| t_a | | | | 22 | | ns |
| Q_{rr} | Reverse recovery charge | | | 40 | | nC |
| I_{rrm} | Reverse recovery current | | | 2.1 | | A |
| S | Softness factor of the diode | | | 0.68 | | |
| t_{rr} | Reverse recovery time | $I_f = 7\text{ A}$, $V_R = 40\text{ V}$, $T_j = 125\text{ }^\circ\text{C}$, $di/dt = 100\text{ A}/\mu\text{s}$ | | 61 | | ns |
| t_a | | | | 34 | | ns |
| Q_{rr} | Reverse recovery charge | | | 98 | | nC |
| I_{rrm} | Reverse recovery current | | | 3.2 | | A |
| S | Softness factor of the diode | | 0.79 | | | |

2.1 Electrical characteristics (curves)

Figure 2. Output characteristics

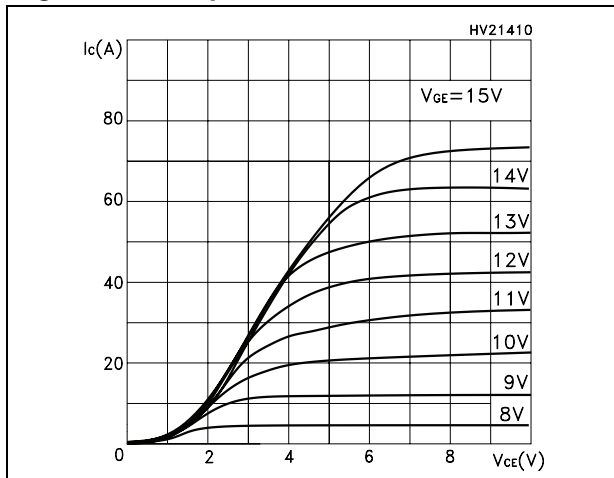

Figure 3. Transfer characteristics

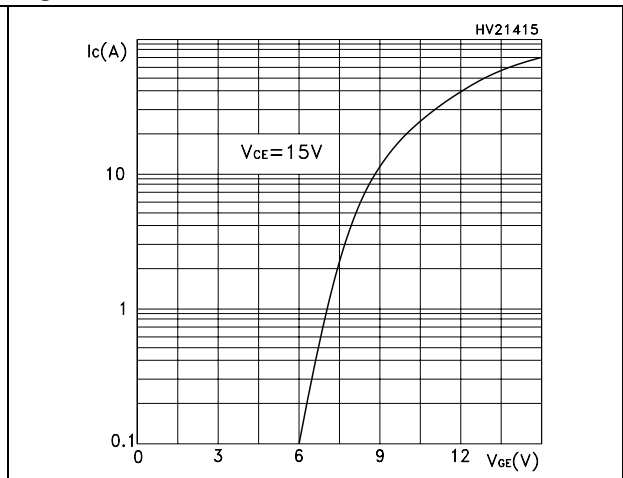

Figure 4. Transconductance

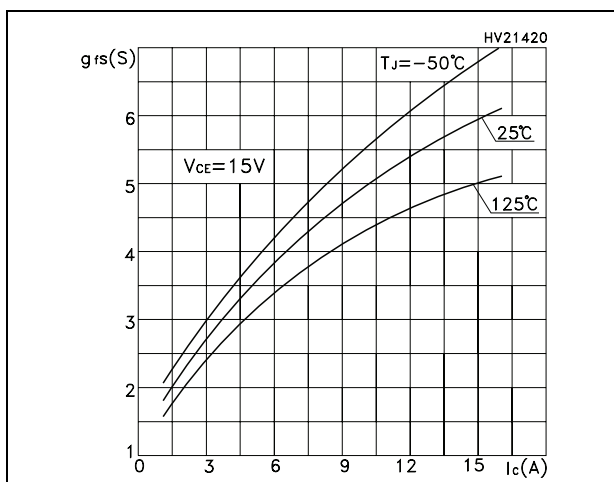

Figure 5. Collector-emitter on voltage vs. temperature

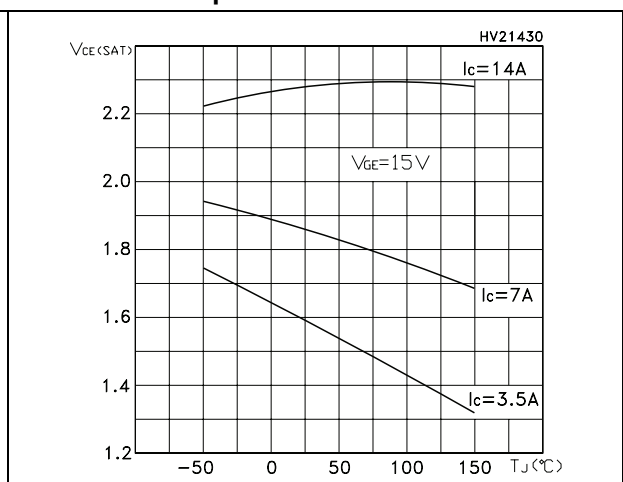

Figure 6. Collector-emitter on voltage vs. collector current

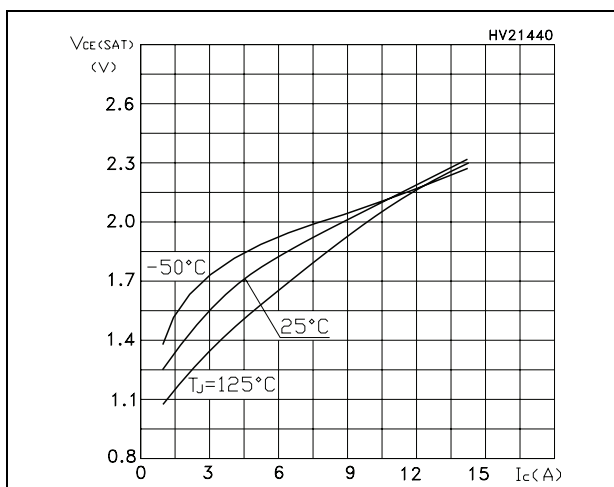

Figure 7. Normalized gate threshold vs. temperature

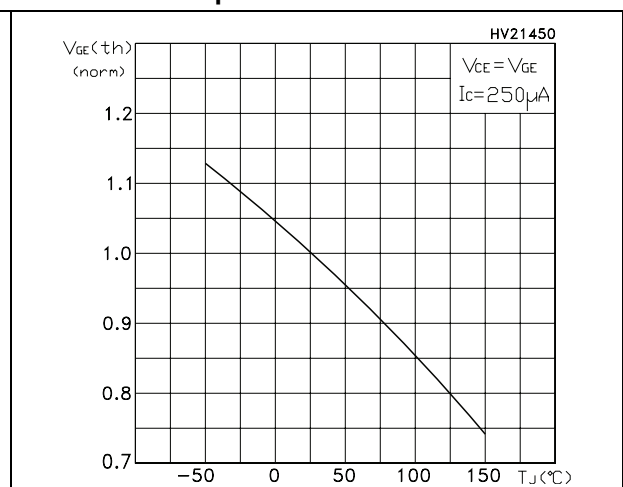

Figure 8. Normalized breakdown voltage vs temperature

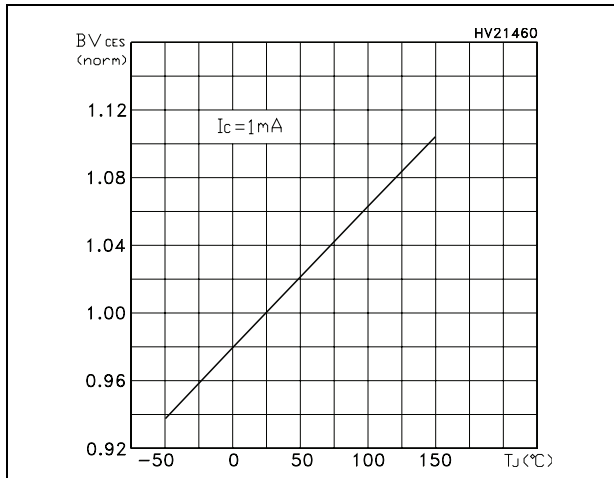

Figure 9. Gate charge vs. gate-emitter voltage

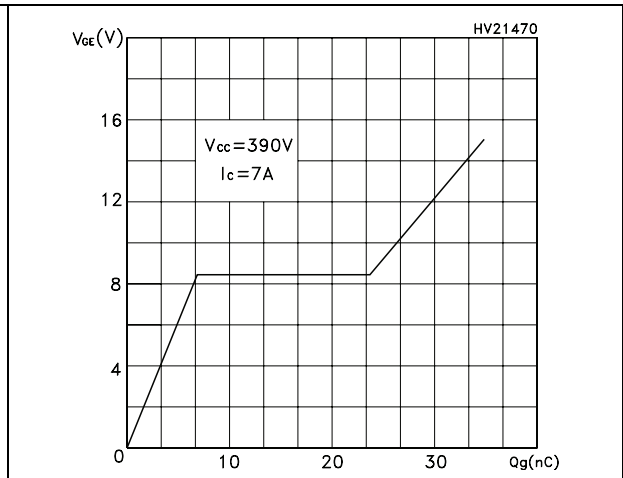

Figure 10. Capacitance variations

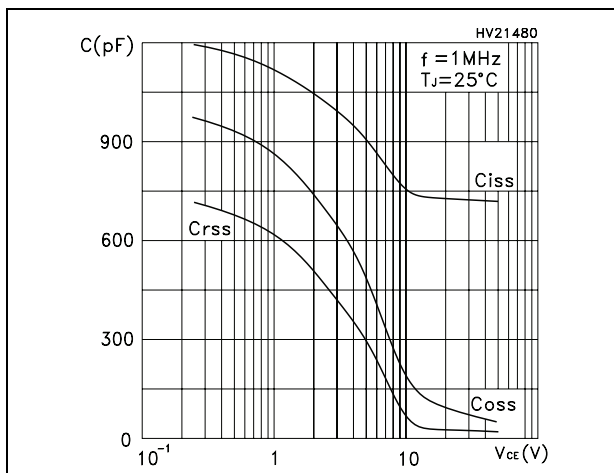

Figure 11. Total switching losses vs. temperature

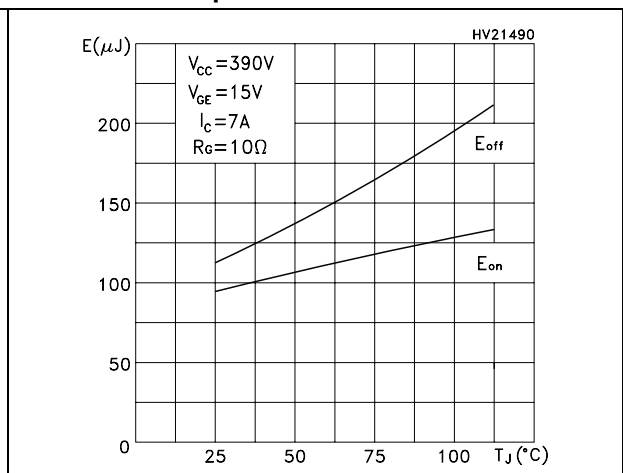

Figure 12. Total switching losses vs. gate resistance

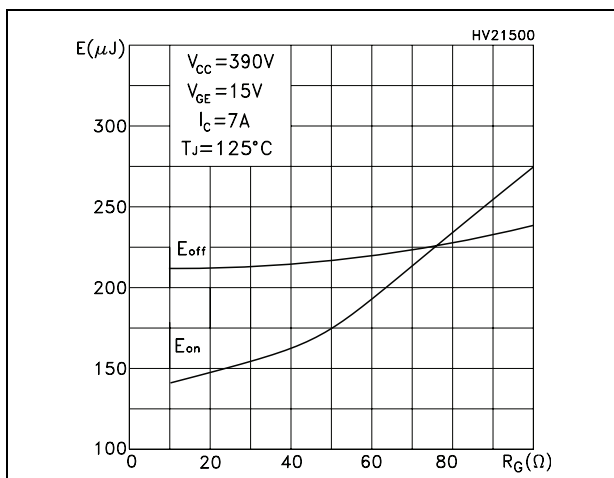

Figure 13. Total switching losses vs collector current

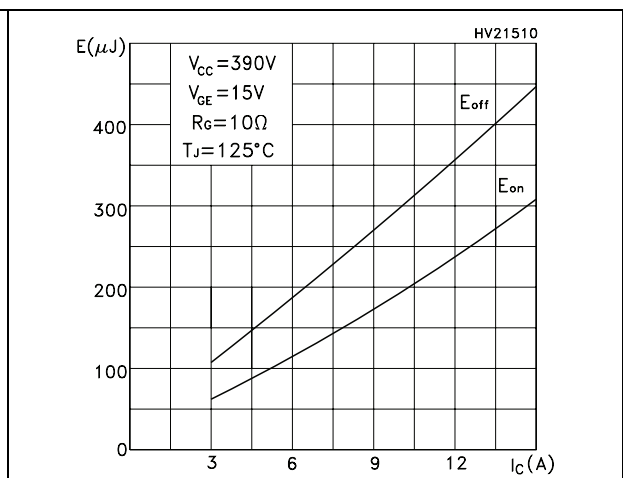

Figure 14. Emitter-collector diode characteristics

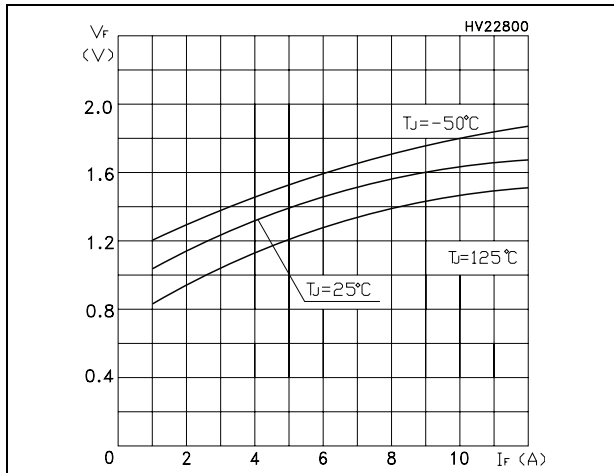

Figure 15. Turn-off SOA

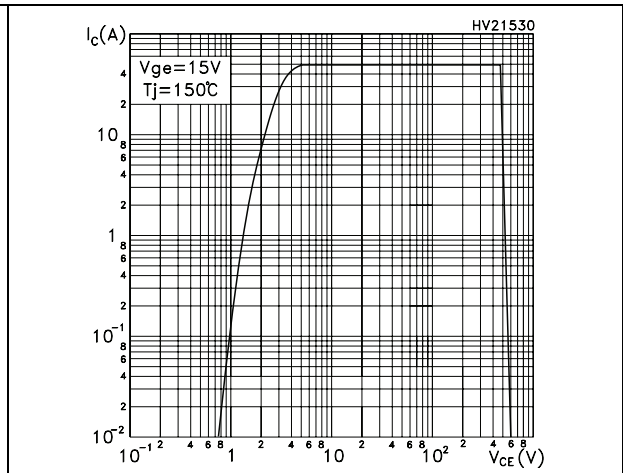

Figure 16. Thermal impedance for I²PAK, D²PAK and TO-220

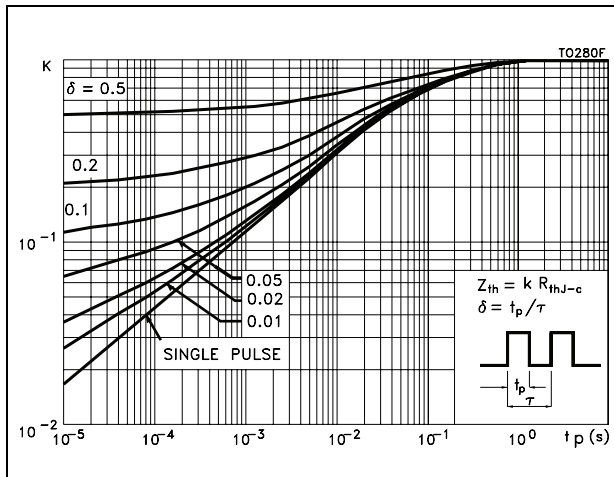
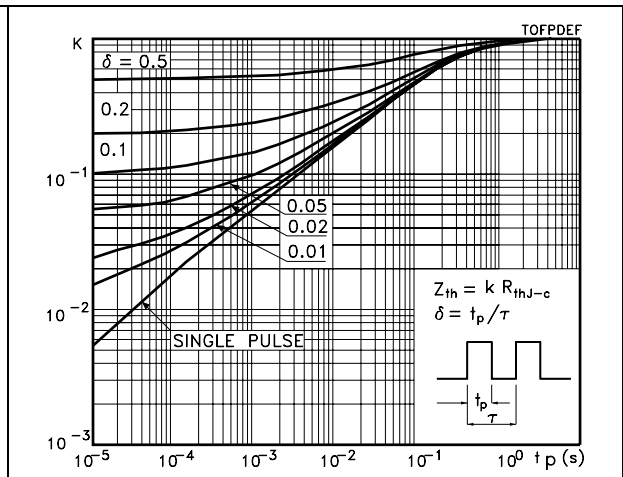
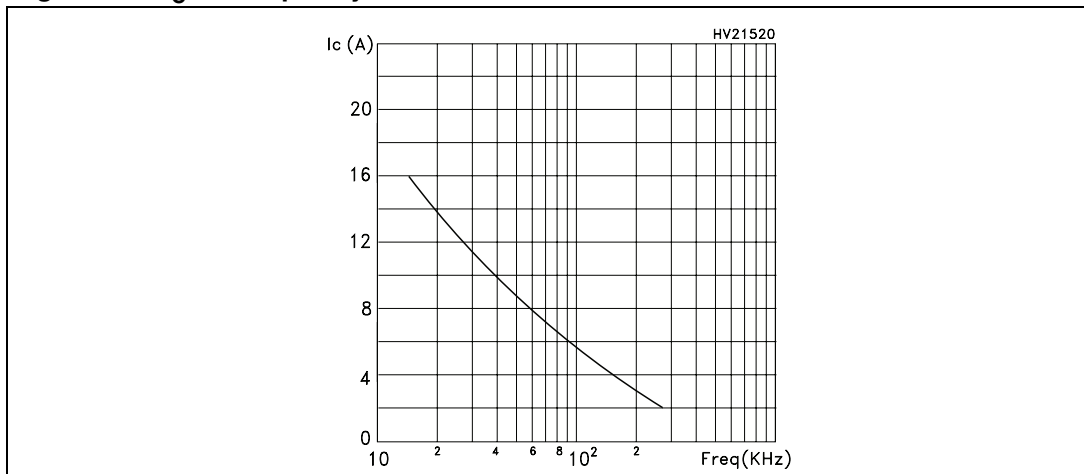

Figure 17. Thermal impedance for TO-220FP



2.2 Operating frequency

Figure 18. I_C vs. frequency



For a fast IGBT suitable for high frequency applications, the typical collector current vs. maximum operating frequency curve is reported. That frequency is defined as follows:

Equation 1

$$f_{MAX} = (P_D - P_C) / (E_{ON} + E_{OFF})$$

The maximum power dissipation is limited by maximum junction to case thermal resistance:

Equation 2

$$P_D = \Delta T / R_{THJ-C}$$

considering $\Delta T = T_J - T_C = 125\text{ }^\circ\text{C} - 75\text{ }^\circ\text{C} = 50\text{ }^\circ\text{C}$

The conduction losses are:

Equation 3

$$P_C = I_C * V_{CE(SAT)} * \delta$$

with 50% of duty cycle, $V_{CE(sat)}$ typical value $T_C = 125\text{ }^\circ\text{C}$.

Power dissipation during ON & OFF commutations is due to the switching frequency:

Equation 4

$$P_{SW} = (E_{ON} + E_{OFF}) * \text{freq.}$$

Typical values $T_C = 125\text{ }^\circ\text{C}$ for switching losses are used (test conditions: $V_{CE} = 390\text{ V}$, $V_{GE} = 15\text{ V}$, $R_G = 3.3\text{ }\Omega$). Furthermore, diode recovery energy is included in the E_{ON} , while the tail of the collector current is included in the E_{OFF} measurements.

4 Package mechanical data

In order to meet environmental requirements, ST offers these devices in different grades of ECOPACK® packages, depending on their level of environmental compliance. ECOPACK® specifications, grade definitions and product status are available at: www.st.com. ECOPACK is an ST trademark.

Table 10. I²PAK (TO-262) mechanical data

| Dim. | mm. | | |
|------|------|------|-------|
| | Min. | Typ. | Max. |
| A | 4.40 | | 4.60 |
| A1 | 2.40 | | 2.72 |
| b | 0.61 | | 0.88 |
| b1 | 1.14 | | 1.70 |
| c | 0.49 | | 0.70 |
| c2 | 1.23 | | 1.32 |
| D | 8.95 | | 9.35 |
| e | 2.40 | | 2.70 |
| e1 | 4.95 | | 5.15 |
| E | 10 | | 10.40 |
| L | 13 | | 14 |
| L1 | 3.50 | | 3.93 |
| L2 | 1.27 | | 1.40 |

Figure 23. I²PAK (TO-262) drawing

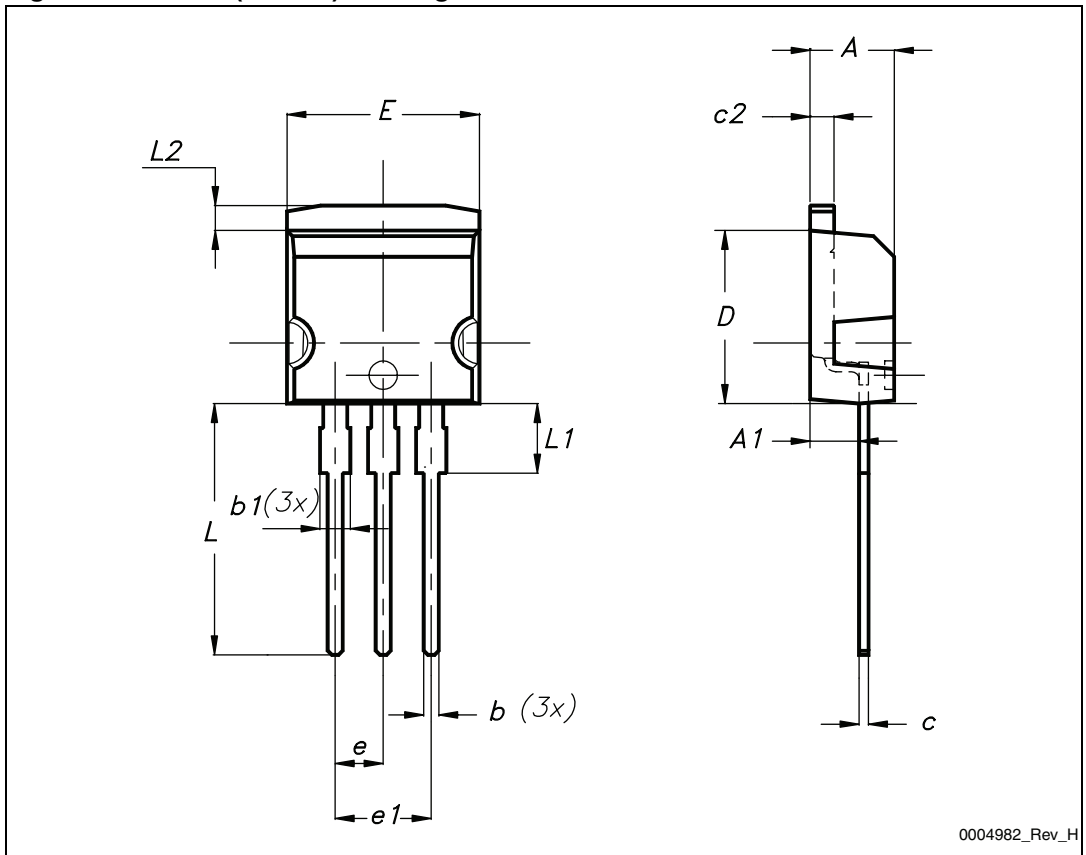

Table 11. D²PAK (TO-263) mechanical data

| Dim. | mm | | |
|------|------|------|-------|
| | Min. | Typ. | Max. |
| A | 4.40 | | 4.60 |
| A1 | 0.03 | | 0.23 |
| b | 0.70 | | 0.93 |
| b2 | 1.14 | | 1.70 |
| c | 0.45 | | 0.60 |
| c2 | 1.23 | | 1.36 |
| D | 8.95 | | 9.35 |
| D1 | 7.50 | | |
| E | 10 | | 10.40 |
| E1 | 8.50 | | |
| e | | 2.54 | |
| e1 | 4.88 | | 5.28 |
| H | 15 | | 15.85 |
| J1 | 2.49 | | 2.69 |
| L | 2.29 | | 2.79 |
| L1 | 1.27 | | 1.40 |
| L2 | 1.30 | | 1.75 |
| R | | 0.4 | |
| V2 | 0° | | 8° |

Figure 24. D²PAK (TO-263) drawing

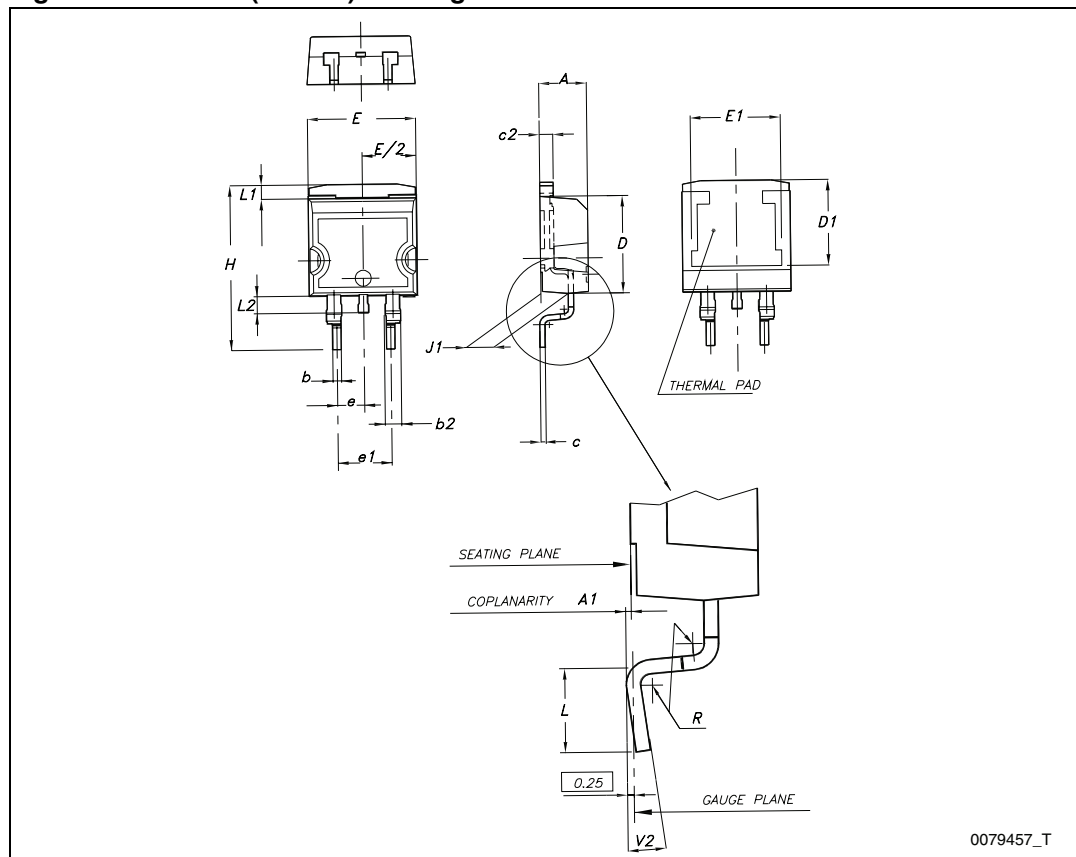
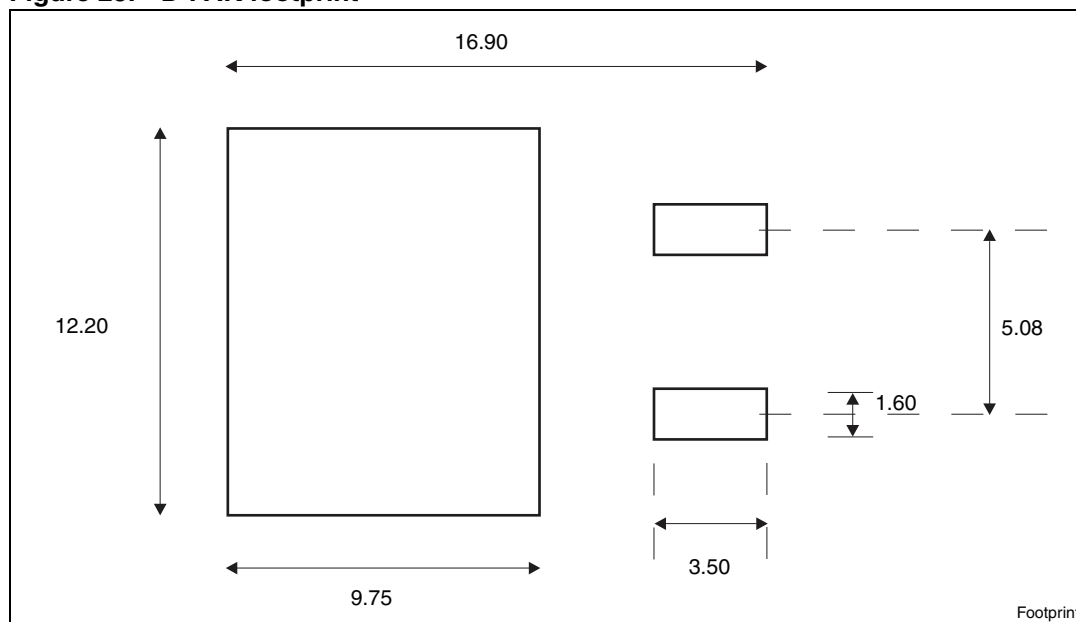

Figure 25. D²PAK footprint^(a)



a. All dimensions are in millimeters

Table 12. TO-220FP mechanical data

| Dim. | mm | | |
|------|------|------|------|
| | Min. | Typ. | Max. |
| A | 4.4 | | 4.6 |
| B | 2.5 | | 2.7 |
| D | 2.5 | | 2.75 |
| E | 0.45 | | 0.7 |
| F | 0.75 | | 1 |
| F1 | 1.15 | | 1.70 |
| F2 | 1.15 | | 1.70 |
| G | 4.95 | | 5.2 |
| G1 | 2.4 | | 2.7 |
| H | 10 | | 10.4 |
| L2 | | 16 | |
| L3 | 28.6 | | 30.6 |
| L4 | 9.8 | | 10.6 |
| L5 | 2.9 | | 3.6 |
| L6 | 15.9 | | 16.4 |
| L7 | 9 | | 9.3 |
| Dia | 3 | | 3.2 |

Figure 26. TO-220FP drawing

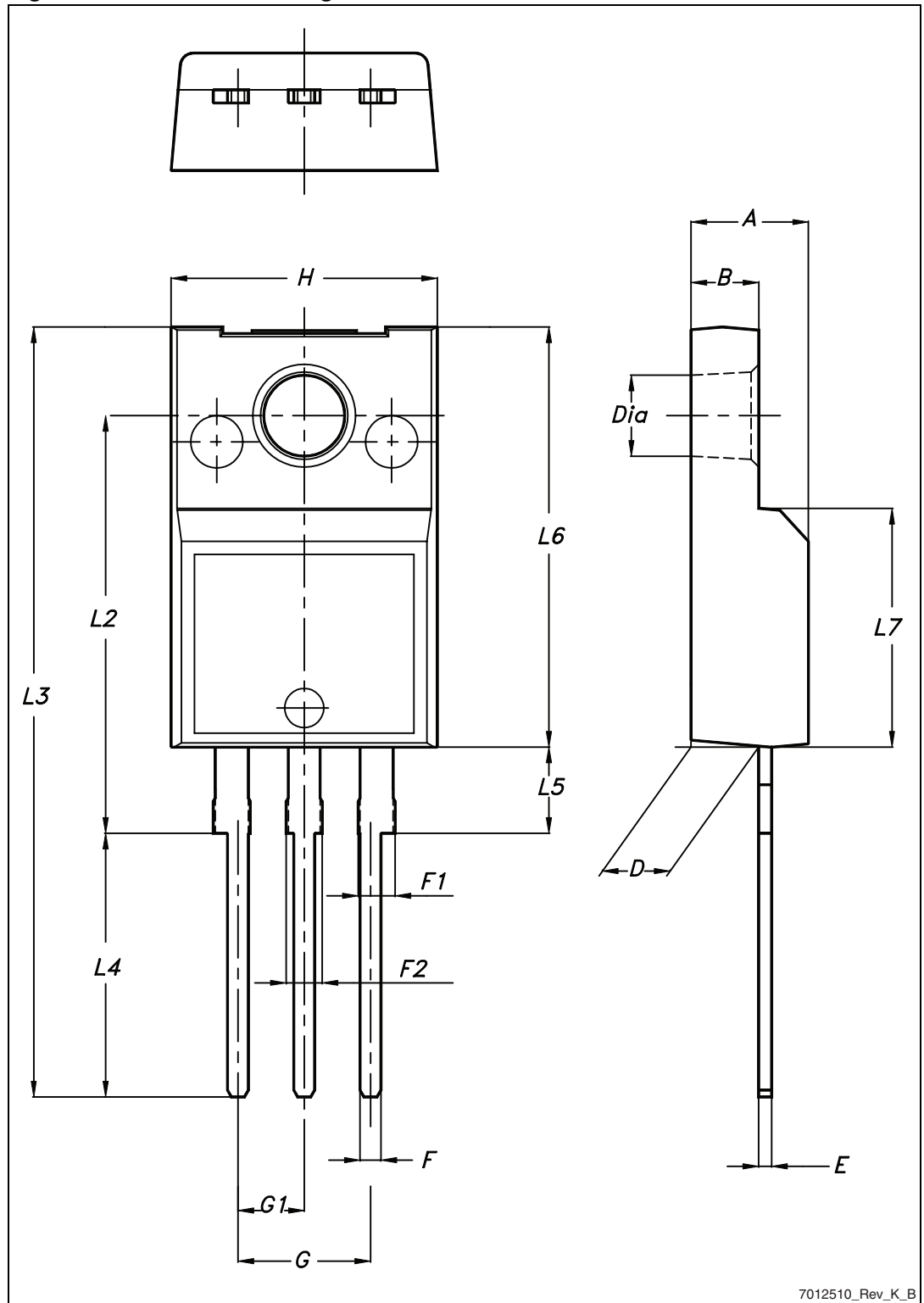

7012510_Rev_K_B

Table 13. TO-220 type A mechanical data

| Dim. | mm | | |
|------|-------|-------|-------|
| | Min. | Typ. | Max. |
| A | 4.40 | | 4.60 |
| b | 0.61 | | 0.88 |
| b1 | 1.14 | | 1.70 |
| c | 0.48 | | 0.70 |
| D | 15.25 | | 15.75 |
| D1 | | 1.27 | |
| E | 10 | | 10.40 |
| e | 2.40 | | 2.70 |
| e1 | 4.95 | | 5.15 |
| F | 1.23 | | 1.32 |
| H1 | 6.20 | | 6.60 |
| J1 | 2.40 | | 2.72 |
| L | 13 | | 14 |
| L1 | 3.50 | | 3.93 |
| L20 | | 16.40 | |
| L30 | | 28.90 | |
| ∅P | 3.75 | | 3.85 |
| Q | 2.65 | | 2.95 |

Figure 27. TO-220 type A drawing

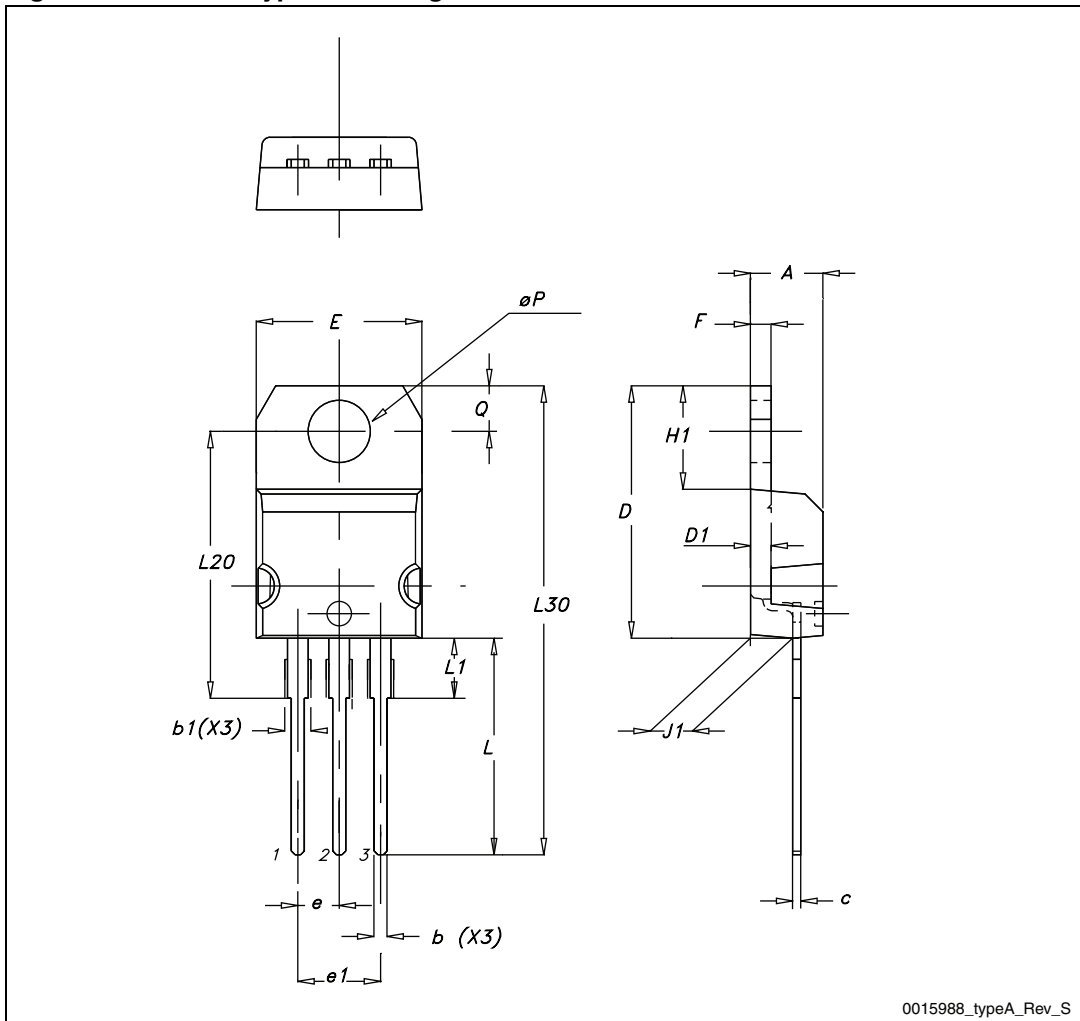

5 Packaging mechanical data

Table 14. D²PAK (TO-263) tape and reel mechanical data

| Tape | | | Reel | | |
|------|------|------|------|----------|------|
| Dim. | mm | | Dim. | mm | |
| | Min. | Max. | | Min. | Max. |
| A0 | 10.5 | 10.7 | A | | 330 |
| B0 | 15.7 | 15.9 | B | 1.5 | |
| D | 1.5 | 1.6 | C | 12.8 | 13.2 |
| D1 | 1.59 | 1.61 | D | 20.2 | |
| E | 1.65 | 1.85 | G | 24.4 | 26.4 |
| F | 11.4 | 11.6 | N | 100 | |
| K0 | 4.8 | 5.0 | T | | 30.4 |
| P0 | 3.9 | 4.1 | | | |
| P1 | 11.9 | 12.1 | | Base qty | 1000 |
| P2 | 1.9 | 2.1 | | Bulk qty | 1000 |
| R | 50 | | | | |
| T | 0.25 | 0.35 | | | |
| W | 23.7 | 24.3 | | | |

Figure 28. Tape

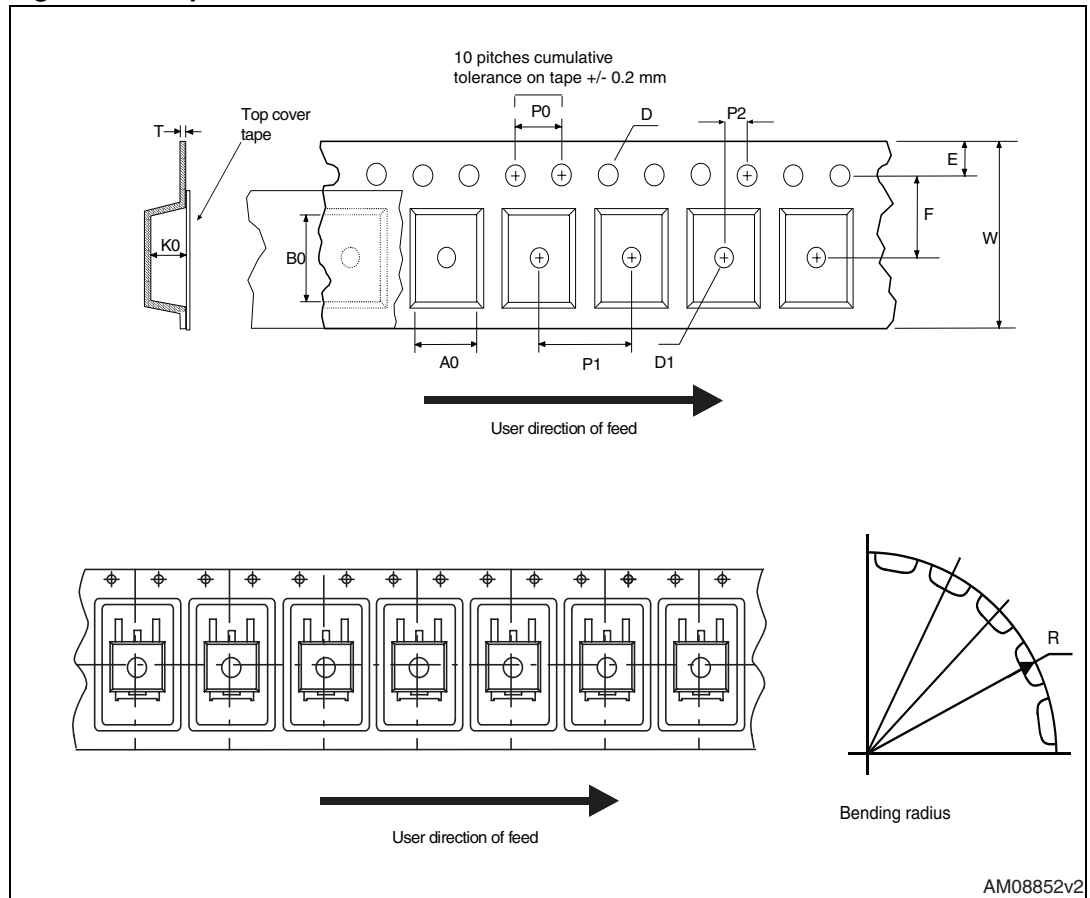

AM08852v2

Figure 29. Reel

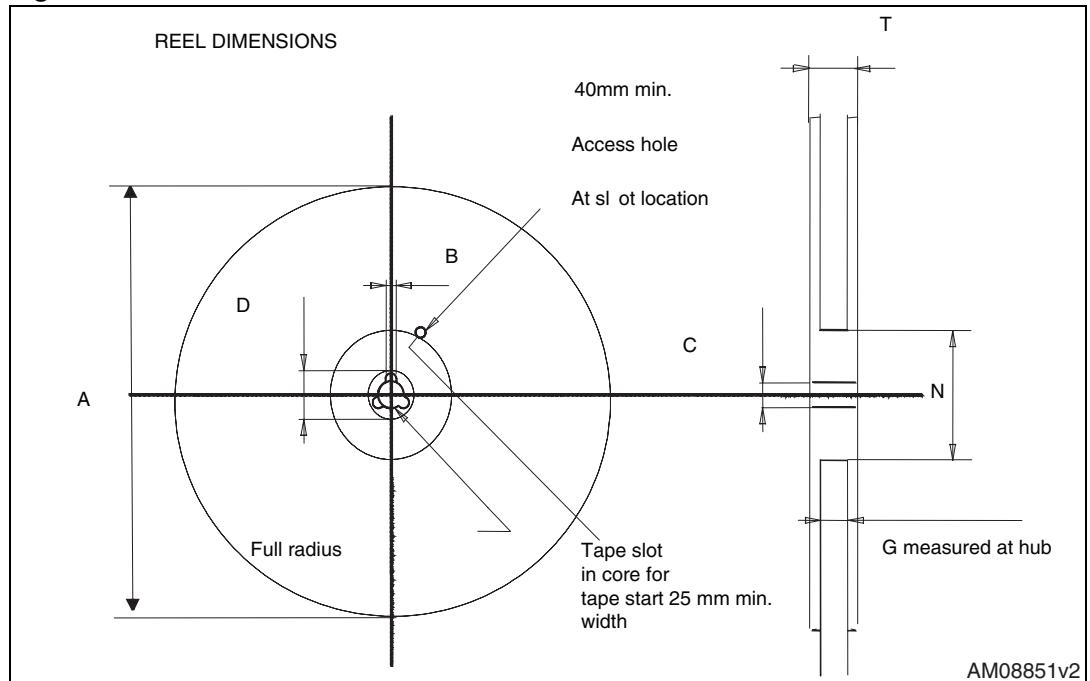

AM08851v2

6 Revision history

Table 15. Document revision history

| Date | Revision | Changes |
|-------------|----------|--|
| 07-Jun-2004 | 4 | Stylesheet update. No content change. |
| 19-Aug-2004 | 5 | Complete version |
| 17-Sep-2004 | 6 | <i>Figure 14</i> has been added |
| 09-Nov-2004 | 7 | Final datasheet |
| 19-Jan-2005 | 8 | Datasheet updated |
| 09-Jun-2005 | 9 | Modified title |
| 27-Jun-2012 | 10 | Inserted commercial type STGB7NC60HD. Minor text changes. |

Please Read Carefully:

Information in this document is provided solely in connection with ST products. STMicroelectronics NV and its subsidiaries ("ST") reserve the right to make changes, corrections, modifications or improvements, to this document, and the products and services described herein at any time, without notice.

All ST products are sold pursuant to ST's terms and conditions of sale.

Purchasers are solely responsible for the choice, selection and use of the ST products and services described herein, and ST assumes no liability whatsoever relating to the choice, selection or use of the ST products and services described herein.

No license, express or implied, by estoppel or otherwise, to any intellectual property rights is granted under this document. If any part of this document refers to any third party products or services it shall not be deemed a license grant by ST for the use of such third party products or services, or any intellectual property contained therein or considered as a warranty covering the use in any manner whatsoever of such third party products or services or any intellectual property contained therein.

UNLESS OTHERWISE SET FORTH IN ST'S TERMS AND CONDITIONS OF SALE ST DISCLAIMS ANY EXPRESS OR IMPLIED WARRANTY WITH RESPECT TO THE USE AND/OR SALE OF ST PRODUCTS INCLUDING WITHOUT LIMITATION IMPLIED WARRANTIES OF MERCHANTABILITY, FITNESS FOR A PARTICULAR PURPOSE (AND THEIR EQUIVALENTS UNDER THE LAWS OF ANY JURISDICTION), OR INFRINGEMENT OF ANY PATENT, COPYRIGHT OR OTHER INTELLECTUAL PROPERTY RIGHT.

UNLESS EXPRESSLY APPROVED IN WRITING BY TWO AUTHORIZED ST REPRESENTATIVES, ST PRODUCTS ARE NOT RECOMMENDED, AUTHORIZED OR WARRANTED FOR USE IN MILITARY, AIR CRAFT, SPACE, LIFE SAVING, OR LIFE SUSTAINING APPLICATIONS, NOR IN PRODUCTS OR SYSTEMS WHERE FAILURE OR MALFUNCTION MAY RESULT IN PERSONAL INJURY, DEATH, OR SEVERE PROPERTY OR ENVIRONMENTAL DAMAGE. ST PRODUCTS WHICH ARE NOT SPECIFIED AS "AUTOMOTIVE GRADE" MAY ONLY BE USED IN AUTOMOTIVE APPLICATIONS AT USER'S OWN RISK.

Resale of ST products with provisions different from the statements and/or technical features set forth in this document shall immediately void any warranty granted by ST for the ST product or service described herein and shall not create or extend in any manner whatsoever, any liability of ST.

ST and the ST logo are trademarks or registered trademarks of ST in various countries.

Information in this document supersedes and replaces all information previously supplied.

The ST logo is a registered trademark of STMicroelectronics. All other names are the property of their respective owners.

© 2012 STMicroelectronics - All rights reserved



STMicroelectronics group of companies

Australia - Belgium - Brazil - Canada - China - Czech Republic - Finland - France - Germany - Hong Kong - India - Israel - Italy - Japan - Malaysia - Malta - Morocco - Philippines - Singapore - Spain - Sweden - Switzerland - United Kingdom - United States of America

www.st.com

Looking for pricing, stock, or lifecycle information?

Click below to explore more details on WIN SOURCE:

-  [View STGF7NC60HD](#) on WIN SOURCE
-  [STMicroelectronics](#) Information

Optimize Your Supply Chain with WIN SOURCE Solutions

-  Global Sourcing Solution
-  Obsolete Management
-  Cost Control Management
-  Shortage Management
-  Alternative Solution
-  Excess Inventory Management