



**THE DATASHEET OF
74LVC161PW-T**



74LVC161

Presettable synchronous 4-bit binary counter; asynchronous reset

Rev. 6 — 30 September 2013

Product data sheet

1. General description

The 74LVC161 is a synchronous presettable binary counter which features an internal look-ahead carry and can be used for high-speed counting. Synchronous operation is provided by having all flip-flops clocked simultaneously on the positive-going edge of the clock (pin CP). The outputs (pins Q0 to Q3) of the counters may be preset to a HIGH-level or LOW-level. A LOW-level at the parallel enable input (pin PE) disables the counting action and causes the data at the data inputs (pins D0 to D3) to be loaded into the counter on the positive-going edge of the clock (provided that the set-up and hold time requirements for PE are met). Preset takes place regardless of the levels at count enable inputs (pins CEP and CET). A LOW-level at the master reset input (pin MR) sets all four outputs of the flip-flops (pins Q0 to Q3) to LOW-level regardless of the levels at input pins CP, \overline{PE} , CET and CEP (thus providing an asynchronous clear function).

The look-ahead carry simplifies serial cascading of the counters. Both count enable inputs (pin CEP and CET) must be HIGH to count. The CET input is fed forward to enable the terminal count output (pin TC). The TC output thus enabled will produce a HIGH output pulse of a duration approximately equal to a HIGH-level output of Q0. This pulse can be used to enable the next cascaded stage.

The maximum clock frequency for the cascaded counters is determined by t_{PHL} (propagation delay CP to TC) and t_{su} (set-up time CEP to CP) according to the formula:

$$f_{max} = \frac{1}{t_{PHL(max)} + t_{su}}$$

It is a high-performance, low-power, low-voltage, Si-gate CMOS device and superior to most advanced CMOS compatible TTL families.

2. Features and benefits

- 5 V tolerant inputs for interfacing with 5 V logic
- Wide supply voltage range from 1.2 V to 3.6 V
- CMOS low power consumption
- Direct interface with TTL levels
- Asynchronous reset
- Synchronous counting and loading
- Two count enable inputs for n-bit cascading
- Positive edge-triggered clock
- Complies with JEDEC standard:
 - ◆ JESD8-7A (1.65 V to 1.95 V)
 - ◆ JESD8-5A (2.3 V to 2.7 V)

- ◆ JESD8-C/JESD36 (2.7 V to 3.6 V)
- Specified from -40 °C to +85 °C and -40 °C to +125 °C
- ESD protection:
 - ◆ HBM JESD22-A114F exceeds 2000 V
 - ◆ MM JESD22-A115-B exceeds 200 V
 - ◆ CDM JESD22-C101E exceeds 1000 V

3. Ordering information

Table 1. Ordering information

Type number	Package			Version
	Temperature range	Name	Description	
74LVC161D	-40 °C to +125 °C	SO16	plastic small outline package; 16 leads; body width 3.9 mm	SOT109-1
74LVC161DB	-40 °C to +125 °C	SSOP16	plastic shrink small outline package; 16 leads; body width 5.3 mm	SOT338-1
74LVC161PW	-40 °C to +125 °C	TSSOP16	plastic thin shrink small outline package; 16 leads; body width 4.4 mm	SOT403-1
74LVC161BQ	-40 °C to +125 °C	DHVQFN16	plastic dual in-line compatible thermal enhanced very thin quad flat package; no leads; 16 terminals; body 2.5 × 3.5 × 0.85 mm	SOT763-1

4. Functional diagram

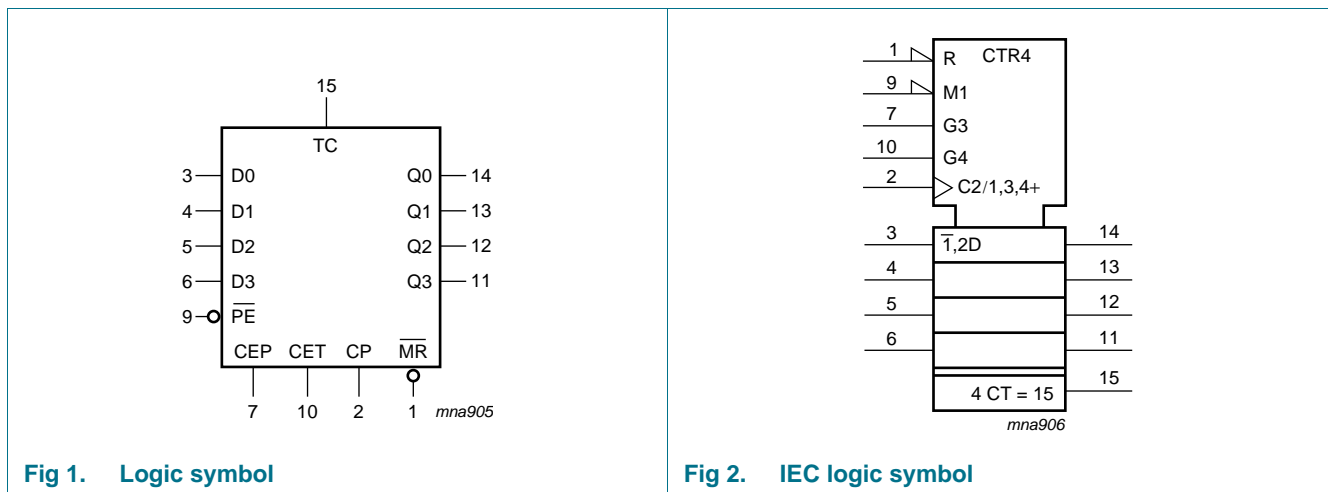

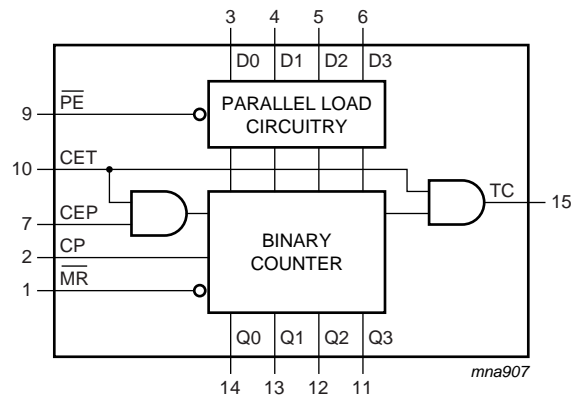

Fig 3. Functional diagram

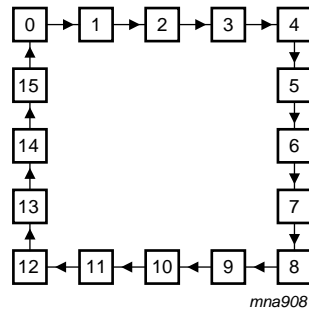

Fig 4. State diagram

5. Pinning information

5.1 Pinning

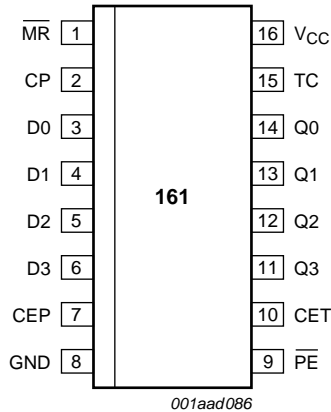
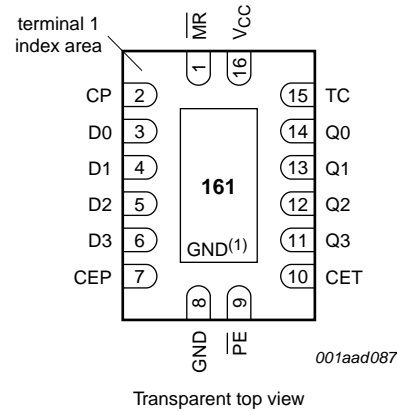

Fig 5. Pin configuration for SO16 and (T)SSOP16



- (1) This is not a supply pin. The substrate is attached to this pad using conductive die attach material. There is no electrical or mechanical requirement to solder this pad. However, if it is soldered, the solder land should remain floating or be connected to GND.

Fig 6. Pin configuration for DHVQFN16

5.2 Pin description

Table 2. Pin description

Symbol	Pin	Description
$\overline{\text{MR}}$	1	synchronous master reset (active LOW)
CP	2	clock input (LOW-to-HIGH, edge-triggered)
D[0:3]	3, 4, 5, 6	data input
CEP	7	count enable input
GND	8	ground (0 V)
$\overline{\text{PE}}$	9	parallel enable input (active LOW)
CET	10	count enable carry input
Q[0:3]	14, 13, 12, 11	flip-flop output
TC	15	terminal count output
V _{CC}	16	supply voltage

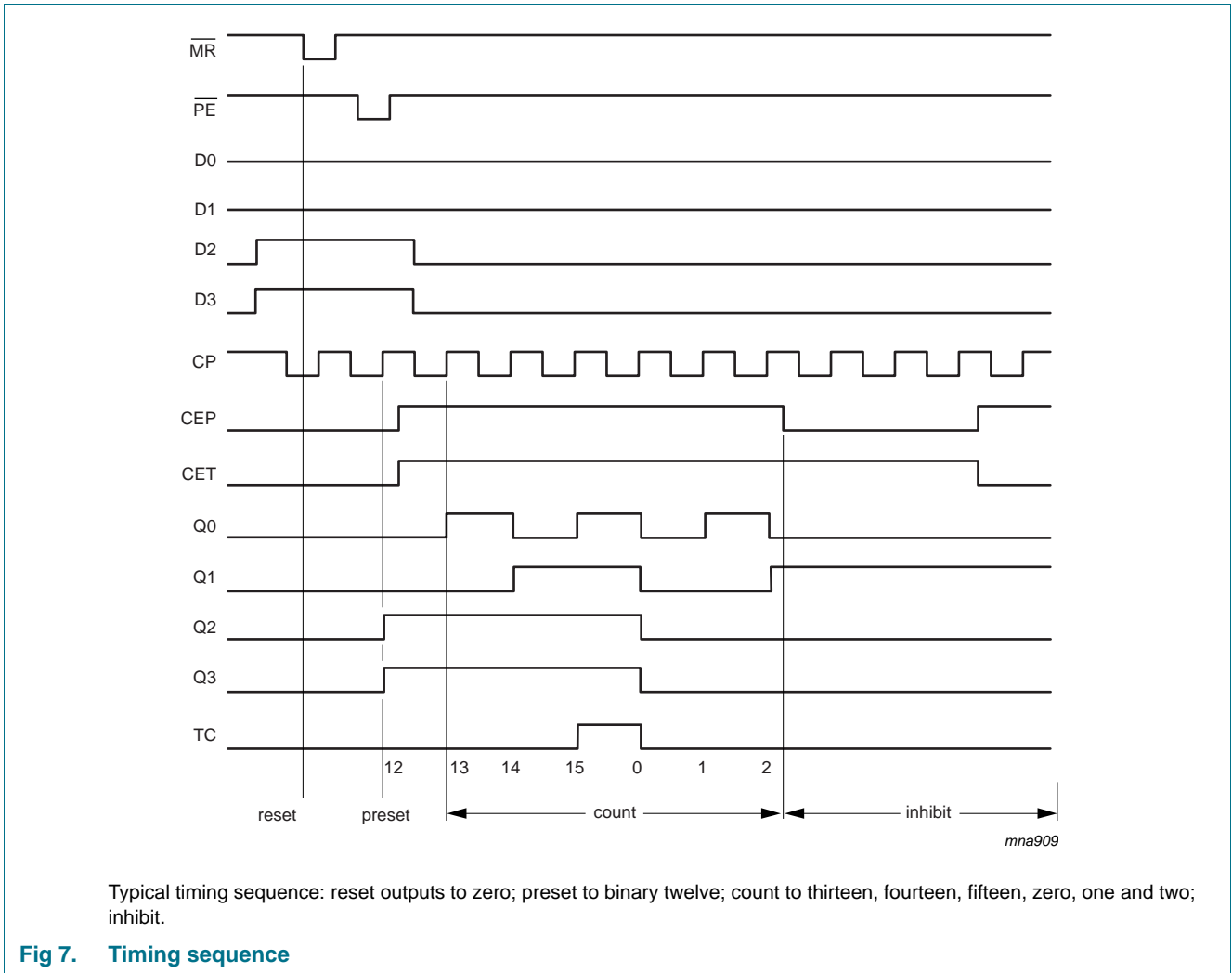

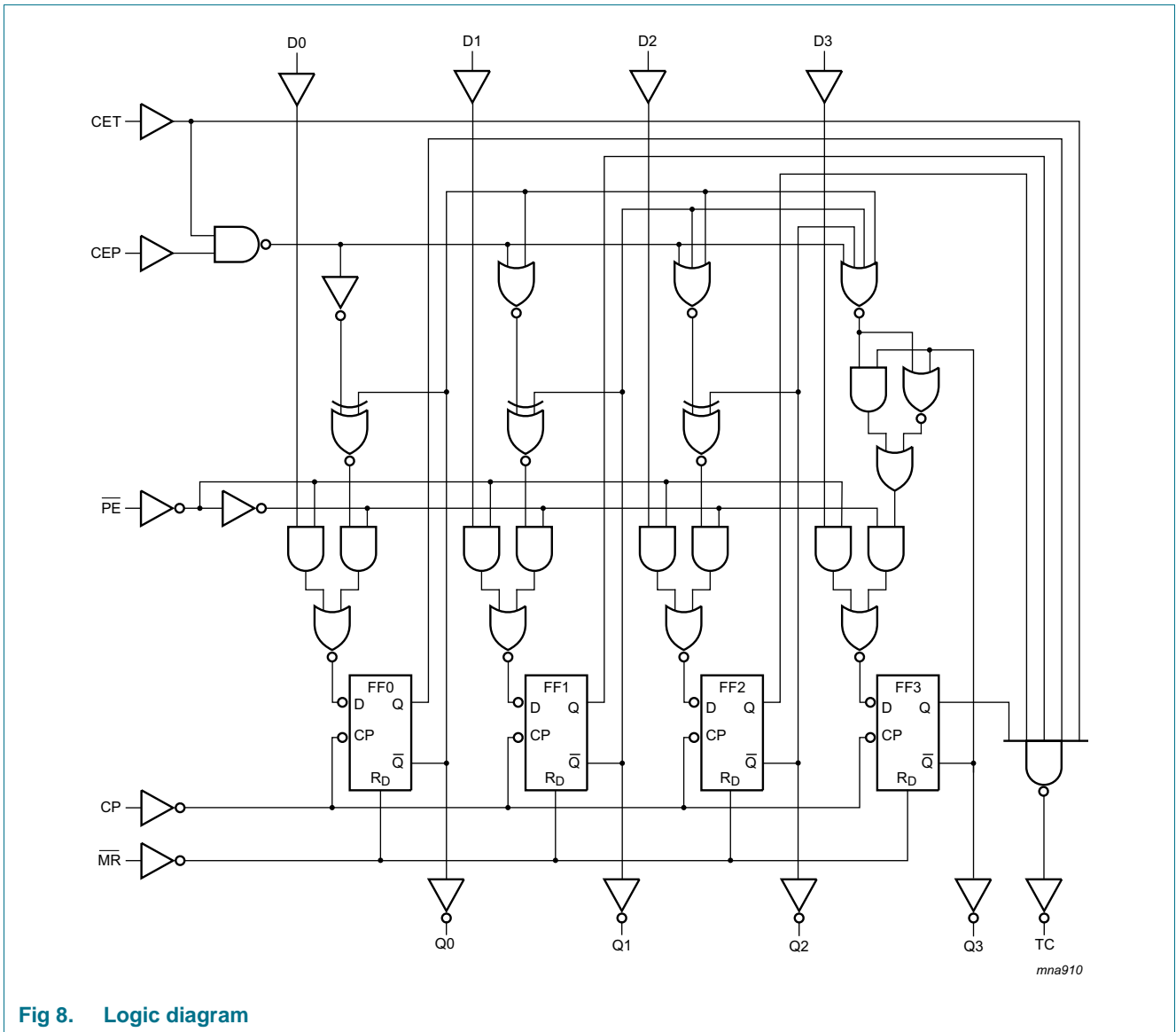

Fig 8. Logic diagram

6. Functional description

Table 3. Function table^[1]

Operating modes	Input						Output	
	MR	CP	CEP	CET	\overline{PE}	Dn	Qn	TC
Reset (clear)	L	X	X	X	X	X	L	L
Parallel load	H	↑	X	X	l	l	L	L
	H	↑	X	X	l	h	H	*
Count	H	↑	h	h	h	X	count	*
Hold (do nothing)	H	X	l	X	h	X	q _n	*
	H	X	X	l	h	X	q _n	L

[1] * = the TC output is HIGH when CET is HIGH and the counter is at terminal count (HHHH)

H = HIGH voltage level

h = HIGH voltage level one set-up time prior to the LOW-to-HIGH clock transition

L = LOW voltage level

l = LOW voltage level one set-up time prior to the LOW-to-HIGH clock transition

q = lower case letters indicate the state of the referenced output one set-up time prior to the LOW-to-HIGH clock transition

X = don't care

↑ = LOW-to-HIGH clock transition

7. Limiting values

Table 4. Limiting values

In accordance with the Absolute Maximum Rating System (IEC 60134). Voltages are referenced to GND (ground = 0 V).

Symbol	Parameter	Conditions	Min	Max	Unit
V _{CC}	supply voltage		-0.5	+6.5	V
I _{IK}	input clamping current	V _I < 0	-50	-	mA
V _I	input voltage		[1] -0.5	+6.5	V
I _{OK}	output clamping current	V _O > V _{CC} or V _O < 0	-	±50	mA
V _O	output voltage		[2] -0.5	V _{CC} + 0.5	V
I _O	output current	V _O = 0 V to V _{CC}	-	±50	mA
I _{CC}	supply current		-	100	mA
I _{GND}	ground current		-100	-	mA
T _{stg}	storage temperature		-65	+150	°C
P _{tot}	total power dissipation	T _{amb} = -40 °C to +125 °C	[3] -	500	mW

[1] The minimum input voltage ratings may be exceeded if the input current ratings are observed.

[2] The output voltage ratings may be exceeded if the output current ratings are observed.

[3] For SO16 packages: above 70 °C the value of P_D derates linearly with 8 mW/K.

For (T)SSOP16 packages: above 60 °C the value of P_D derates linearly with 5.5 mW/K.

For DHVQFN16 packages: above 60 °C the value of P_D derates linearly with 4.5 mW/K.

8. Recommended operating conditions

Table 5. Recommended operating conditions

Symbol	Parameter	Conditions	Min	Typ	Max	Unit
V _{CC}	supply voltage		1.65	-	3.6	V
		functional	1.2	-	-	V
V _I	input voltage		0	-	5.5	V
V _O	output voltage		0	-	V _{CC}	V
T _{amb}	ambient temperature	in free air	-40	-	+125	°C
Δt/ΔV	input transition rise and fall rate	V _{CC} = 1.65 V to 2.7 V	0	-	20	ns/V
		V _{CC} = 2.7 V to 3.6 V	0	-	10	ns/V

9. Static characteristics

Table 6. Static characteristics

At recommended operating conditions. Voltages are referenced to GND (ground = 0 V).

Symbol	Parameter	Conditions	-40 °C to +85 °C			-40 °C to +125 °C		Unit
			Min	Typ ^[1]	Max	Min	Max	
V _{IH}	HIGH-level input voltage	V _{CC} = 1.2 V	1.08	-	-	1.08	-	V
		V _{CC} = 1.65 V to 1.95 V	0.65 × V _{CC}	-	-	0.65 × V _{CC}	-	V
		V _{CC} = 2.3 V to 2.7 V	1.7	-	-	1.7	-	V
		V _{CC} = 2.7 V to 3.6 V	2.0	-	-	2.0	-	V
V _{IL}	LOW-level input voltage	V _{CC} = 1.2 V	-	-	0.12	-	0.12	V
		V _{CC} = 1.65 V to 1.95 V	-	-	0.35 × V _{CC}	-	0.35 × V _{CC}	V
		V _{CC} = 2.3 V to 2.7 V	-	-	0.7	-	0.7	V
		V _{CC} = 2.7 V to 3.6 V	-	-	0.8	-	0.8	V
V _{OH}	HIGH-level output voltage	V _I = V _{IH} or V _{IL}						
		I _O = -100 μA; V _{CC} = 1.65 V to 3.6 V	V _{CC} - 0.2	-	-	V _{CC} - 0.3	-	V
		I _O = -4 mA; V _{CC} = 1.65 V	1.2	-	-	1.05	-	V
		I _O = -8 mA; V _{CC} = 2.3 V	1.8	-	-	1.65	-	V
		I _O = -12 mA; V _{CC} = 2.7 V	2.2	-	-	2.05	-	V
		I _O = -18 mA; V _{CC} = 3.0 V	2.4	-	-	2.25	-	V
V _{OL}	LOW-level output voltage	V _I = V _{IH} or V _{IL}						
		I _O = 100 μA; V _{CC} = 1.65 V to 3.6 V	-	-	0.2	-	0.3	V
		I _O = 4 mA; V _{CC} = 1.65 V	-	-	0.45	-	0.65	V
		I _O = 8 mA; V _{CC} = 2.3 V	-	-	0.6	-	0.8	V
		I _O = 12 mA; V _{CC} = 2.7 V	-	-	0.4	-	0.6	V
		I _O = 24 mA; V _{CC} = 3.0 V	-	-	0.55	-	0.8	V
I _I	input leakage current	V _{CC} = 3.6 V; V _I = 5.5 V or GND	-	±0.1	±5	-	±20	μA

Table 6. Static characteristics ...continued

At recommended operating conditions. Voltages are referenced to GND (ground = 0 V).

Symbol	Parameter	Conditions	-40 °C to +85 °C			-40 °C to +125 °C		Unit
			Min	Typ ^[1]	Max	Min	Max	
I _{CC}	supply current	V _{CC} = 3.6 V; V _I = V _{CC} or GND; I _O = 0 A	-	0.1	10	-	40	μA
ΔI _{CC}	additional supply current	per input pin; V _{CC} = 2.7 V to 3.6 V; V _I = V _{CC} - 0.6 V; I _O = 0 A	-	5	500	-	5000	μA
C _I	input capacitance	V _{CC} = 0 V to 3.6 V; V _I = GND to V _{CC}	-	5.0	-	-	-	pF

[1] All typical values are measured at V_{CC} = 3.3 V (unless stated otherwise) and T_{amb} = 25 °C.

10. Dynamic characteristics

Table 7. Dynamic characteristicsVoltages are referenced to GND (ground = 0 V). For test circuit see [Figure 14](#).

Symbol	Parameter	Conditions	-40 °C to +85 °C			-40 °C to +125 °C		Unit
			Min	Typ ^[1]	Max	Min	Max	
t _{pd}	propagation delay	CP to Q _n ; see Figure 9 ^[2]						
		V _{CC} = 1.2 V	-	17	-	-	-	ns
		V _{CC} = 1.65 V to 1.95 V	1.5	7.0	14.5	1.5	16.7	ns
		V _{CC} = 2.3 V to 2.7 V	2.5	4.0	8.1	2.5	9.4	ns
		V _{CC} = 2.7 V	1.5	3.8	7.2	1.5	9.0	ns
		V _{CC} = 3.0 V to 3.6 V	1.5	3.6	7.3	1.5	9.5	ns
		CP to TC; see Figure 9 ^[2]						
		V _{CC} = 1.2 V	-	20	-	-	-	ns
		V _{CC} = 1.65 V to 1.95 V	1.8	8.1	15.5	1.8	17.9	ns
		V _{CC} = 2.3 V to 2.7 V	2.8	4.6	8.7	2.8	10.1	ns
		V _{CC} = 2.7 V	1.5	4.3	7.8	1.5	10.0	ns
		V _{CC} = 3.0 V to 3.6 V	1.5	4.2	7.8	1.5	10.0	ns
		CET to TC; see Figure 10 ^[2]						
		V _{CC} = 1.2 V	-	16	-	-	-	ns
		V _{CC} = 1.65 V to 1.95 V	1.5	5.9	11.9	1.5	13.7	ns
		V _{CC} = 2.3 V to 2.7 V	1.9	3.4	6.7	1.9	7.7	ns
		V _{CC} = 2.7 V	1.5	3.6	6.5	1.5	8.5	ns
		V _{CC} = 3.0 V to 3.6 V	1.5	3.1	6.0	1.5	7.5	ns

Table 7. Dynamic characteristics ...continuedVoltages are referenced to GND (ground = 0 V). For test circuit see [Figure 14](#).

Symbol	Parameter	Conditions	-40 °C to +85 °C			-40 °C to +125 °C		Unit		
			Min	Typ ^[1]	Max	Min	Max			
t _{PHL}	HIGH to LOW propagation delay	$\overline{\text{MR}}$ to Qn; see Figure 11								
		V _{CC} = 1.2 V	-	17	-	-	-	ns		
		V _{CC} = 1.65 V to 1.95 V	1.5	6.2	12.7	1.5	14.6	ns		
		V _{CC} = 2.3 V to 2.7 V	1.9	3.6	7.1	1.9	8.3	ns		
		V _{CC} = 2.7 V	1.5	3.9	7.1	1.5	9.0	ns		
		V _{CC} = 3.0 V to 3.6 V	1.5	3.2	6.4	1.5	8.0	ns		
		$\overline{\text{MR}}$ to TC; see Figure 11								
		V _{CC} = 1.2 V	-	18	-	-	-	ns		
		V _{CC} = 1.65 V to 1.95 V	1.7	8.3	15.9	1.7	18.4	ns		
		V _{CC} = 2.3 V to 2.7 V	2.7	4.8	8.9	2.7	10.3	ns		
		V _{CC} = 2.7 V	1.5	4.9	8.6	1.5	11.0	ns		
		V _{CC} = 3.0 V to 3.6 V	1.5	4.3	8.0	1.5	10.0	ns		
t _w	pulse width	clock HIGH or LOW; see Figure 9								
		V _{CC} = 1.65 V to 1.95 V	6.0	-	-	6.0	-	ns		
		V _{CC} = 2.3 V to 2.7 V	5.0	-	-	5.0	-	ns		
		V _{CC} = 2.7 V	5.0	-	-	5.0	-	ns		
		V _{CC} = 3.0 V to 3.6 V	4.0	1.2	-	4.0	-	ns		
		master reset LOW; see Figure 11								
		V _{CC} = 1.65 V to 1.95 V	5.0	-	-	5.0	-	ns		
		V _{CC} = 2.3 V to 2.7 V	4.0	-	-	4.0	-	ns		
		V _{CC} = 2.7 V	4.0	-	-	4.0	-	ns		
		V _{CC} = 3.0 V to 3.6 V	3.0	1.6	-	3.0	-	ns		
		t _{rec}	recovery time	$\overline{\text{MR}}$ to CP; see Figure 11						
				V _{CC} = 1.65 V to 1.95 V	1.0	-	-	1.0	-	ns
V _{CC} = 2.3 V to 2.7 V	1.0			-	-	1.0	-	ns		
V _{CC} = 2.7 V	0.0			-	-	0.0	-	ns		
V _{CC} = 3.0 V to 3.6 V	0.5			0.0	-	0.5	-	ns		

Table 7. Dynamic characteristics ...continuedVoltages are referenced to GND (ground = 0 V). For test circuit see [Figure 14](#).

Symbol	Parameter	Conditions	-40 °C to +85 °C			-40 °C to +125 °C		Unit	
			Min	Typ ^[1]	Max	Min	Max		
t _{su}	set-up time	Dn to CP; see Figure 12							
		V _{CC} = 1.65 V to 1.95 V	5.0	-	-	5.0	-	ns	
		V _{CC} = 2.3 V to 2.7 V	4.0	-	-	4.0	-	ns	
		V _{CC} = 2.7 V	3.0	-	-	3.0	-	ns	
		V _{CC} = 3.0 V to 3.6 V	2.5	1.0	-	2.5	-	ns	
		PE̅ to CP; see Figure 12							
		V _{CC} = 1.65 V to 1.95 V	4.5	-	-	4.5	-	ns	
		V _{CC} = 2.3 V to 2.7 V	4.0	-	-	4.0	-	ns	
		V _{CC} = 2.7 V	3.5	-	-	3.5	-	ns	
		V _{CC} = 3.0 V to 3.6 V	3.0	1.2	-	3.0	-	ns	
		CEP, CET to CP; see Figure 13							
		V _{CC} = 1.65 V to 1.95 V	8.0	-	-	8.0	-	ns	
V _{CC} = 2.3 V to 2.7 V	6.0	-	-	6.0	-	ns			
V _{CC} = 2.7 V	5.5	-	-	5.5	-	ns			
V _{CC} = 3.0 V to 3.6 V	5.0	2.1	-	5.0	-	ns			
t _h	hold time	Dn, PE̅, CEP, CET to CP; see Figure 12 and 13							
		V _{CC} = 1.65 V to 1.95 V	3.0	-	-	3.0	-	ns	
		V _{CC} = 2.3 V to 2.7 V	2.5	-	-	2.5	-	ns	
		V _{CC} = 2.7 V	0.0	-	-	0.0	-	ns	
		V _{CC} = 3.0 V to 3.6 V	0.5	0.0	-	0.5	-	ns	
f _{max}	maximum frequency	see Figure 9							
		V _{CC} = 1.65 V to 1.95 V	100	-	-	80	-	MHZ	
		V _{CC} = 2.3 V to 2.7 V	125	-	-	100	-	MHZ	
		V _{CC} = 2.7 V	150	-	-	120	-	MHZ	
		V _{CC} = 3.0 V to 3.6 V	150	200	-	120	-	MHZ	
t _{sk(o)}	output skew time	V _{CC} = 3.0 V to 3.6 V	[3]	-	-	1.0	-	1.5	ns
C _{PD}	power dissipation capacitance	per input; V _I = GND to V _{CC}	[4]						
		V _{CC} = 1.65 V to 1.95 V	-	11.1	-			pF	
		V _{CC} = 2.3 V to 2.7 V	-	14.7	-			pF	
		V _{CC} = 3.0 V to 3.6 V	-	17.9	-			pF	

[1] Typical values are measured at T_{amb} = 25 °C and V_{CC} = 1.2 V, 1.8 V, 2.5 V, 2.7 V and 3.3 V respectively.

[2] t_{pd} is the same as t_{PLH} and t_{PHL}.

[3] Skew between any two outputs of the same package switching in the same direction. This parameter is guaranteed by design.

[4] C_{PD} is used to determine the dynamic power dissipation (P_D in μW).

$P_D = C_{PD} \times V_{CC}^2 \times f_i \times N + \sum(C_L \times V_{CC}^2 \times f_o)$ where:

f_i = input frequency in MHz; f_o = output frequency in MHz

C_L = output load capacitance in pF

V_{CC} = supply voltage in V

N = number of inputs switching

$\sum(C_L \times V_{CC}^2 \times f_o)$ = sum of outputs

11. Waveforms

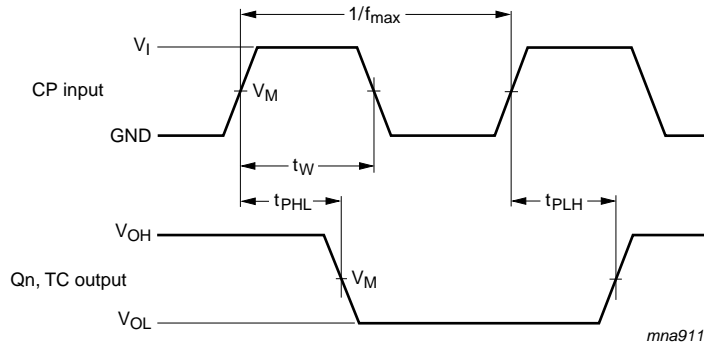

Measurement points are given in [Table 8](#).
 V_{OL} and V_{OH} are typical output voltage levels that occur with the output load.

Fig 9. Clock (CP) to outputs (Qn, TC) propagation delays, the clock pulse width, and maximum frequency

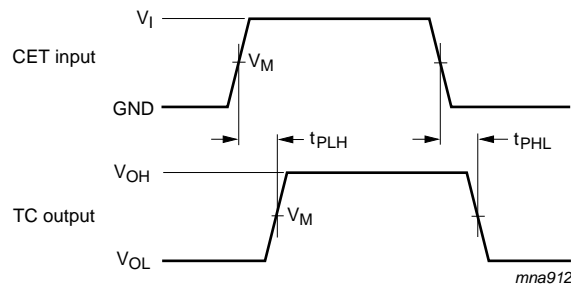

Measurement points are given in [Table 8](#).
 V_{OL} and V_{OH} are typical output voltage levels that occur with the output load.

Fig 10. Input (CET) to output (TC) propagation delays

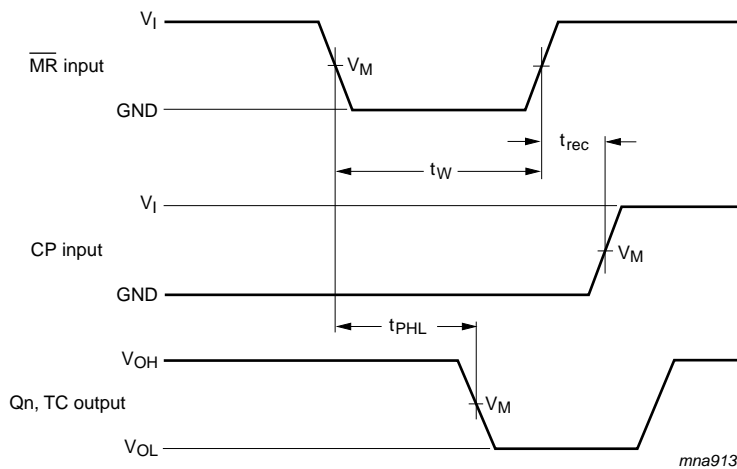
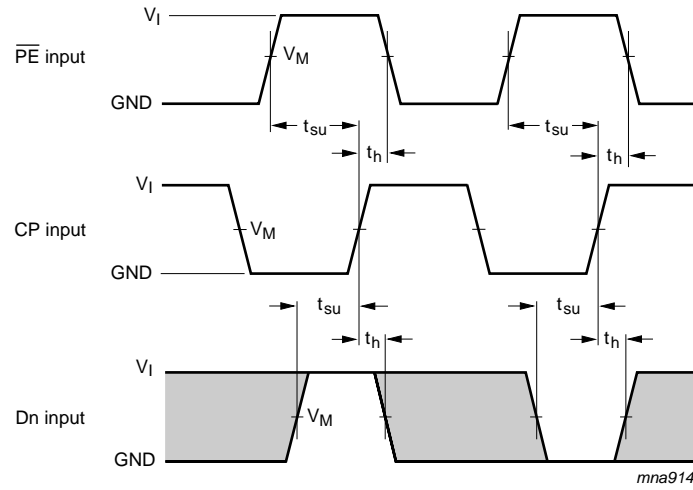
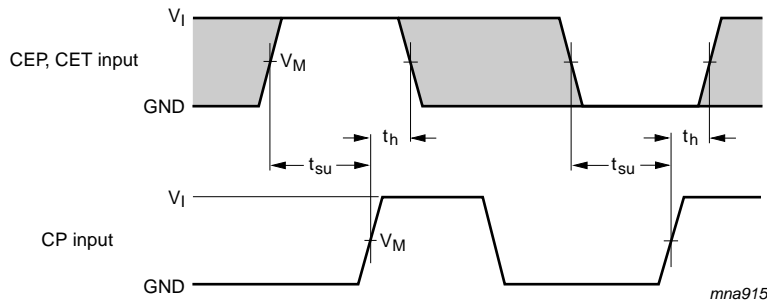

Fig 11. Master reset (\overline{MR}) pulse width, the master reset to output (Qn, TC) propagation delays, and the master reset to clock (CP) removal times



The shaded areas indicate when the input is permitted to change for predictable output performance.

Fig 12. Set-up and hold times for the input (Dn) and parallel enable input (\overline{PE})



The shaded areas indicate when the input is permitted to change for predictable output performance.

Fig 13. CEP and CET set-up and hold times

Table 8. Measurement points

Supply voltage	Input		Output
V_{CC}	V_I	V_M	V_M
1.2 V	V_{CC}	$0.5 \times V_{CC}$	$0.5 \times V_{CC}$
1.65 V to 1.95 V	V_{CC}	$0.5 \times V_{CC}$	$0.5 \times V_{CC}$
2.3 V to 2.7 V	V_{CC}	$0.5 \times V_{CC}$	$0.5 \times V_{CC}$
2.7 V	2.7 V	1.5 V	1.5 V
3.0 V to 3.6 V	2.7 V	1.5 V	1.5 V

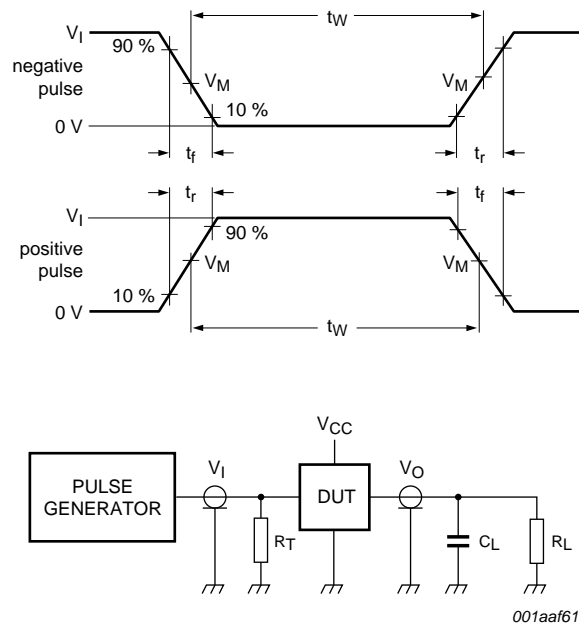

Test data is given in [Table 9](#). Definitions for test circuit:

R_L = Load resistance.

C_L = Load capacitance including jig and probe capacitance.

R_T = Termination resistance should be equal to output impedance Z_o of the pulse generator.

Fig 14. Test circuit for measuring switching times

Table 9. Test data

Supply voltage	Input		Load	
	V_I	t_r, t_f	C_L	R_L
1.2 V	V_{CC}	≤ 2 ns	30 pF	1 k Ω
1.65 V to 1.95 V	V_{CC}	≤ 2 ns	30 pF	1 k Ω
2.3 V to 2.7 V	V_{CC}	≤ 2 ns	30 pF	500 Ω
2.7 V	2.7 V	≤ 2.5 ns	50 pF	500 Ω
3.0 V to 3.6 V	2.7 V	≤ 2.5 ns	50 pF	500 Ω

12. Package outline

SO16: plastic small outline package; 16 leads; body width 3.9 mm

SOT109-1

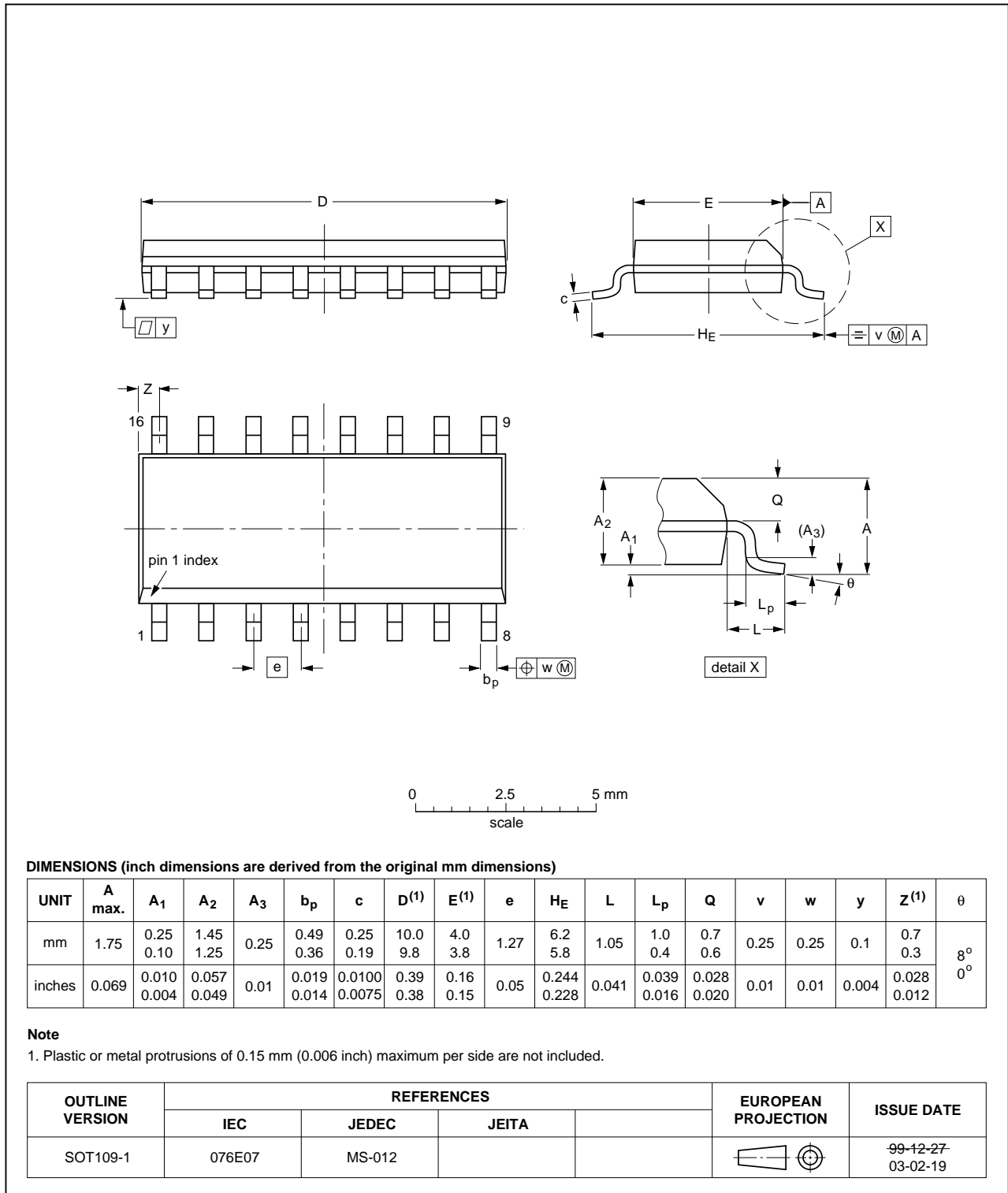

Fig 15. Package outline SOT109-1 (SO16)

SSOP16: plastic shrink small outline package; 16 leads; body width 5.3 mm

SOT338-1

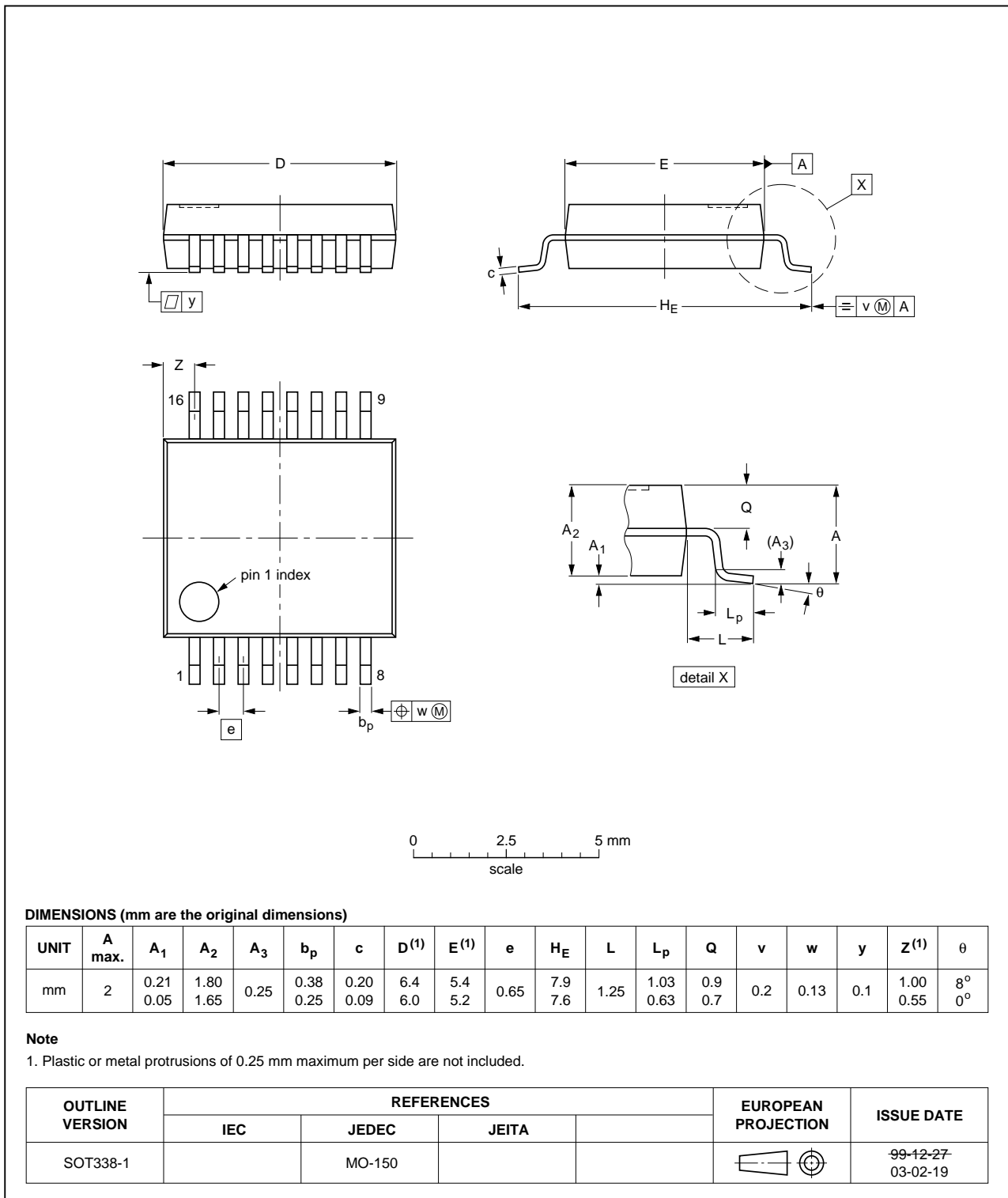

Fig 16. Package outline SOT338-1 (SSOP16)

TSSOP16: plastic thin shrink small outline package; 16 leads; body width 4.4 mm

SOT403-1

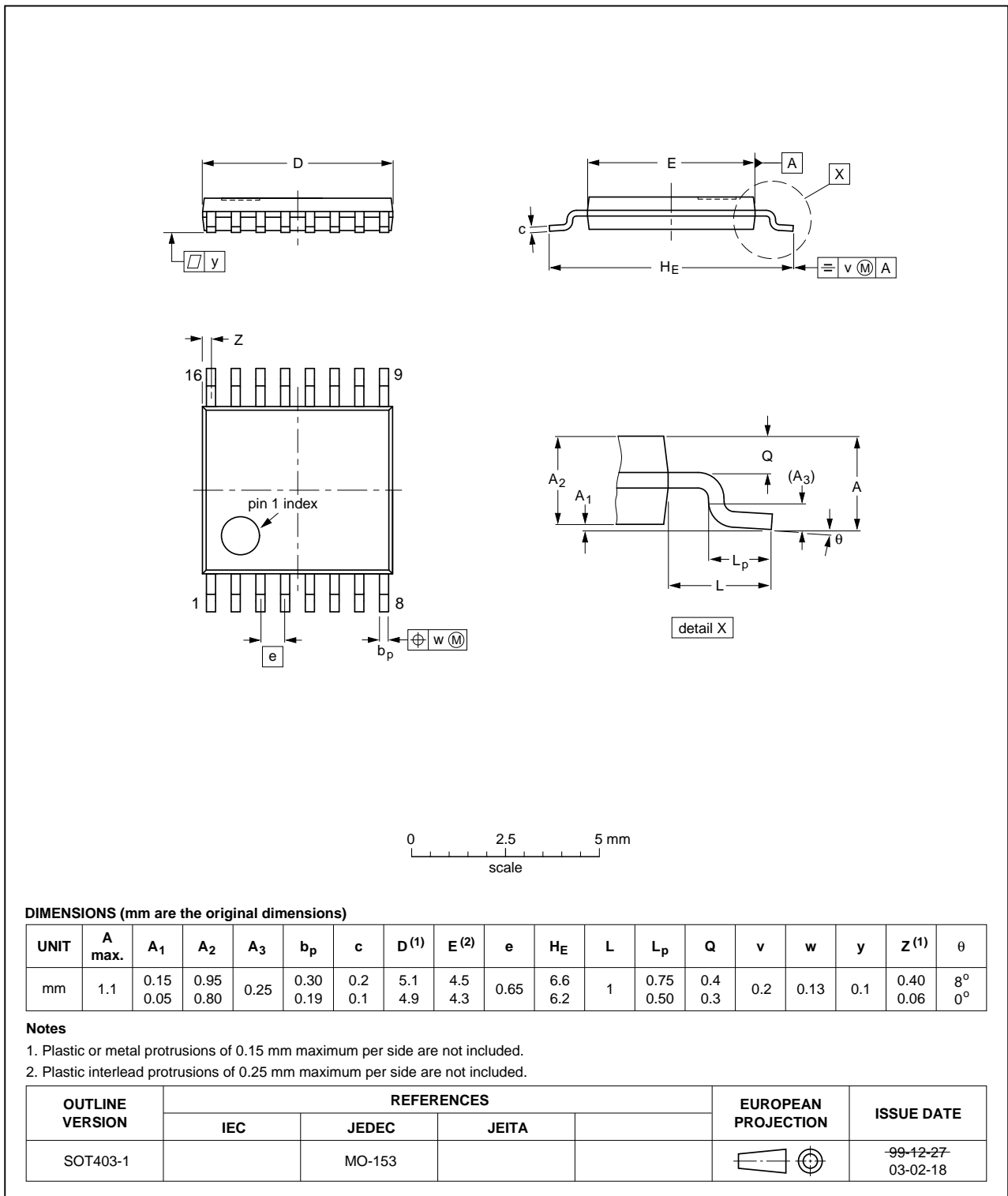

Fig 17. Package outline SOT403-1 (TSSOP16)

DHVQFN16: plastic dual in-line compatible thermal enhanced very thin quad flat package; no leads; 16 terminals; body 2.5 x 3.5 x 0.85 mm

SOT763-1

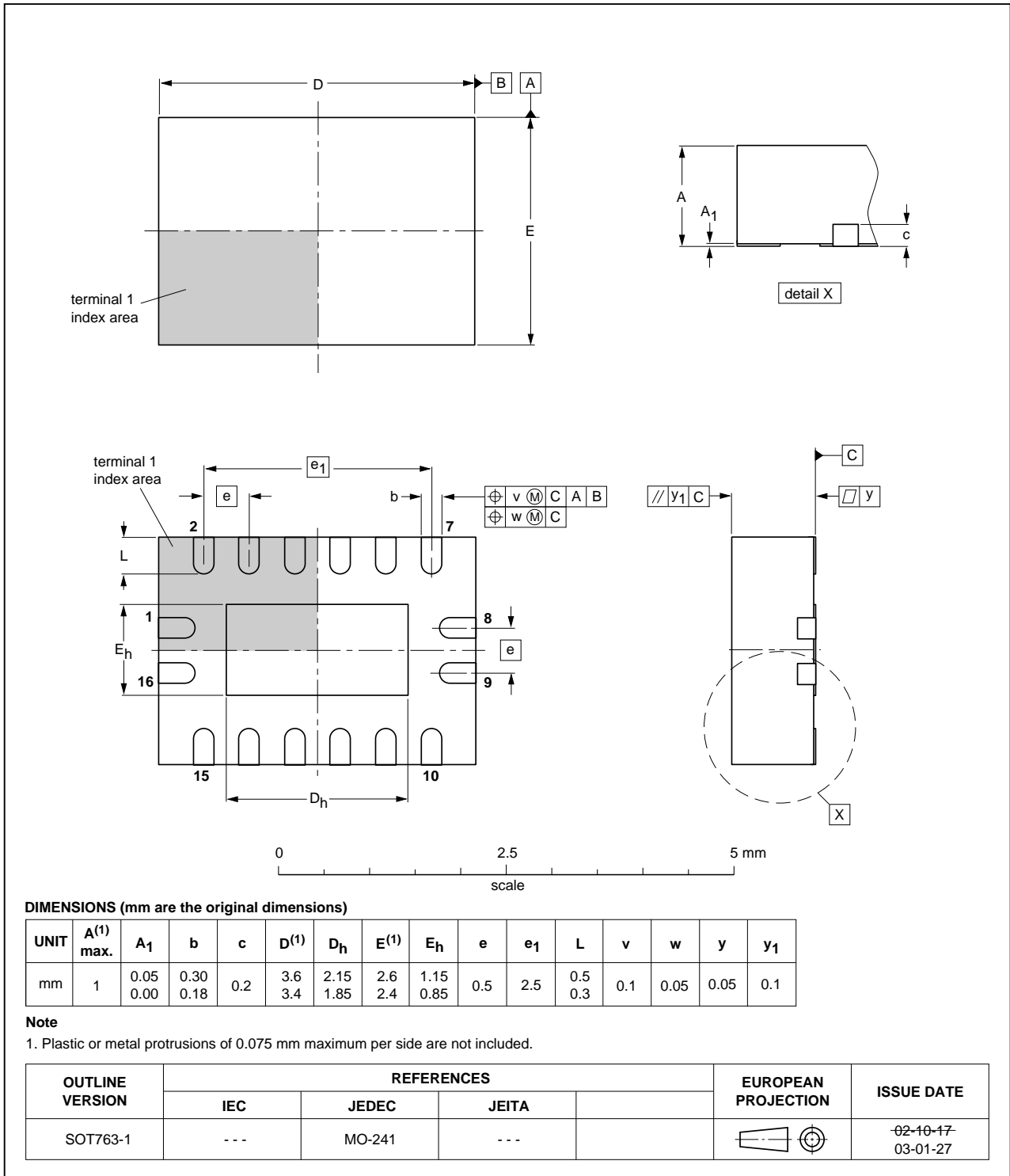

Fig 18. Package outline SOT763-1 (DHVQFN16)

13. Abbreviations

Table 10. Abbreviations

Acronym	Description
CDM	Charged Device Model
DUT	Device Under Test
ESD	ElectroStatic Discharge
HBM	Human Body Model
MM	Machine Model
TTL	Transistor-Transistor Logic

14. Revision history

Table 11. Revision history

Document ID	Release date	Data sheet status	Change notice	Supersedes
74LVC161 v.6	20130930	Product data sheet	-	74LVC161 v.5
Modifications:	<ul style="list-style-type: none"> Figure 8 corrected (errata). 			
74LVC161 v.5	20121123	Product data sheet	-	74LVC161 v.4
74LVC161 v.4	20121122	Product data sheet	-	74LVC161 v.3
74LVC161 v.3	20040330	Product specification	-	74LVC161 v.2
74LVC161 v.2	19980520	Product specification	-	74LVC161 v.1
74LVC161 v.1	19960823	Product specification	-	-

15. Legal information

15.1 Data sheet status

Document status ^{[1][2]}	Product status ^[3]	Definition
Objective [short] data sheet	Development	This document contains data from the objective specification for product development.
Preliminary [short] data sheet	Qualification	This document contains data from the preliminary specification.
Product [short] data sheet	Production	This document contains the product specification.

[1] Please consult the most recently issued document before initiating or completing a design.

[2] The term 'short data sheet' is explained in section "Definitions".

[3] The product status of device(s) described in this document may have changed since this document was published and may differ in case of multiple devices. The latest product status information is available on the Internet at URL <http://www.nexperia.com>.

15.2 Definitions

Draft — The document is a draft version only. The content is still under internal review and subject to formal approval, which may result in modifications or additions. Nexperia does not give any representations or warranties as to the accuracy or completeness of information included herein and shall have no liability for the consequences of use of such information.

Short data sheet — A short data sheet is an extract from a full data sheet with the same product type number(s) and title. A short data sheet is intended for quick reference only and should not be relied upon to contain detailed and full information. For detailed and full information see the relevant full data sheet, which is available on request via the local Nexperia sales office. In case of any inconsistency or conflict with the short data sheet, the full data sheet shall prevail.

Product specification — The information and data provided in a Product data sheet shall define the specification of the product as agreed between Nexperia and its customer, unless Nexperia and customer have explicitly agreed otherwise in writing. In no event however, shall an agreement be valid in which the Nexperia product is deemed to offer functions and qualities beyond those described in the Product data sheet.

15.3 Disclaimers

Limited warranty and liability — Information in this document is believed to be accurate and reliable. However, Nexperia does not give any representations or warranties, expressed or implied, as to the accuracy or completeness of such information and shall have no liability for the consequences of use of such information. Nexperia takes no responsibility for the content in this document if provided by an information source outside of Nexperia.

In no event shall Nexperia be liable for any indirect, incidental, punitive, special or consequential damages (including - without limitation - lost profits, lost savings, business interruption, costs related to the removal or replacement of any products or rework charges) whether or not such damages are based on tort (including negligence), warranty, breach of contract or any other legal theory.

Notwithstanding any damages that customer might incur for any reason whatsoever, Nexperia's aggregate and cumulative liability towards customer for the products described herein shall be limited in accordance with the *Terms and conditions of commercial sale* of Nexperia.

Right to make changes — Nexperia reserves the right to make changes to information published in this document, including without limitation specifications and product descriptions, at any time and without notice. This document supersedes and replaces all information supplied prior to the publication hereof.

Suitability for use — Nexperia products are not designed, authorized or warranted to be suitable for use in life support, life-critical or safety-critical systems or equipment, nor in applications where failure or malfunction of a Nexperia product can reasonably be expected to result in personal injury, death or severe property or environmental damage. Nexperia and its suppliers accept no liability for inclusion and/or use of Nexperia products in such equipment or applications and therefore such inclusion and/or use is at the customer's own risk.

Applications — Applications that are described herein for any of these products are for illustrative purposes only. Nexperia makes no representation or warranty that such applications will be suitable for the specified use without further testing or modification.

Customers are responsible for the design and operation of their applications and products using Nexperia products, and Nexperia accepts no liability for any assistance with applications or customer product design. It is customer's sole responsibility to determine whether the Nexperia product is suitable and fit for the customer's applications and products planned, as well as for the planned application and use of customer's third party customer(s). Customers should provide appropriate design and operating safeguards to minimize the risks associated with their applications and products.

Nexperia does not accept any liability related to any default, damage, costs or problem which is based on any weakness or default in the customer's applications or products, or the application or use by customer's third party customer(s). Customer is responsible for doing all necessary testing for the customer's applications and products using Nexperia products in order to avoid a default of the applications and the products or of the application or use by customer's third party customer(s). Nexperia does not accept any liability in this respect.

Limiting values — Stress above one or more limiting values (as defined in the Absolute Maximum Ratings System of IEC 60134) will cause permanent damage to the device. Limiting values are stress ratings only and (proper) operation of the device at these or any other conditions above those given in the Recommended operating conditions section (if present) or the Characteristics sections of this document is not warranted. Constant or repeated exposure to limiting values will permanently and irreversibly affect the quality and reliability of the device.

Terms and conditions of commercial sale — Nexperia products are sold subject to the general terms and conditions of commercial sale, as published at <http://www.nexperia.com/profile/terms>, unless otherwise agreed in a valid written individual agreement. In case an individual agreement is concluded only the terms and conditions of the respective agreement shall apply. Nexperia hereby expressly objects to applying the customer's general terms and conditions with regard to the purchase of Nexperia products by customer.

No offer to sell or license — Nothing in this document may be interpreted or construed as an offer to sell products that is open for acceptance or the grant, conveyance or implication of any license under any copyrights, patents or other industrial or intellectual property rights.

Export control — This document as well as the item(s) described herein may be subject to export control regulations. Export might require a prior authorization from competent authorities.

Non-automotive qualified products — Unless this data sheet expressly states that this specific Nexperia product is automotive qualified, the product is not suitable for automotive use. It is neither qualified nor tested in accordance with automotive testing or application requirements. Nexperia accepts no liability for inclusion and/or use of non-automotive qualified products in automotive equipment or applications.

In the event that customer uses the product for design-in and use in automotive applications to automotive specifications and standards, customer (a) shall use the product without Nexperia's warranty of the product for such automotive applications, use and specifications, and (b) whenever customer uses the product for automotive applications beyond

Nexperia's specifications such use shall be solely at customer's own risk, and (c) customer fully indemnifies Nexperia for any liability, damages or failed product claims resulting from customer design and use of the product for automotive applications beyond Nexperia's standard warranty and Nexperia's product specifications.

Translations — A non-English (translated) version of a document is for reference only. The English version shall prevail in case of any discrepancy between the translated and English versions.

15.4 Trademarks

Notice: All referenced brands, product names, service names and trademarks are the property of their respective owners.

16. Contact information

For more information, please visit: <http://www.nexperia.com>

For sales office addresses, please send an email to: salesaddresses@nexperia.com

17. Contents

1	General description	1
2	Features and benefits	1
3	Ordering information	2
4	Functional diagram	2
5	Pinning information	4
5.1	Pinning	4
5.2	Pin description	4
6	Functional description	7
7	Limiting values	7
8	Recommended operating conditions	8
9	Static characteristics	8
10	Dynamic characteristics	9
11	Waveforms	12
12	Package outline	15
13	Abbreviations	19
14	Revision history	19
15	Legal information	20
15.1	Data sheet status	20
15.2	Definitions	20
15.3	Disclaimers	20
15.4	Trademarks	21
16	Contact information	21
17	Contents	22

Looking for pricing, stock, or lifecycle information?

Click below to explore more details on WIN SOURCE:

- [View 74LVC161PW-T on WIN SOURCE](#)
- [NXP / Nexperia Information](#)

Optimize Your Supply Chain with WIN SOURCE Solutions

- ✓ Global Sourcing Solution
- ✓ Obsolete Management
- ✓ Cost Control Management
- ✓ Shortage Management
- ✓ Alternative Solution
- ✓ Excess Inventory Management