



**THE DATASHEET OF
STAC9202X5TAEA1XR**



2-CHANNEL HIGH DEFINITION AUDIO CODEC WITH

STAC9202

DESCRIPTION

The STAC9202 is a high fidelity, 2-channel audio CODEC compliant with the High Definition Audio (HD Audio) specification defined by Intel. The STAC9202 implements direct interface to two digital microphones supporting advanced beam forming applications resulting in increased quality of applications requiring voice input.

FEATURES

- **High-integration HD Audio Product**
 - 2-channel PC Audio CODEC
 - Dual Digital Microphone interface
- **Two-Channel DACs and ADCs with 24-bit sample resolution**
 - High performance $\Sigma\Delta$ technology
 - Sample rates up to 192 Hz
 - 100dB DAC SNR
- **Integrated Headphone Amps**
- **Stereo Analog Microphone**
 - Supports Stereo Microphone
 - Microphone Boost 0, 10, 20, 30, 40dB
- **Dual Digital Microphone Interface optimized for use with Akustica Digital Microphones**
- **S/PDIF In and Out**
- **Universal Jacks™ Functionality for jack retasking**
- **Adjustable VREF Out**

- **Digital PC Beep to all outputs**
- **+3.3 V, +4 V and +5 V analog power supply options**
- **48-pin LQFP Environmental Package**

DESCRIPTION

The STAC9202 is a high fidelity, 2-channel, audio CODEC compliant with the High Definition Audio (HD Audio) specification defined by Intel. The STAC9202 provides high quality, HD Audio capability to notebook and cost sensitive desktop PC applications.

The STAC9202 incorporates IDT's proprietary $\Sigma\Delta$ technology to achieve a DAC SNR of 100 dB. The higher performance and quality of IDT's audio solutions brings consumer electronics level performance to the notebook, desktop and media center PC.

The STAC9202 provides stereo, 24-bit, full duplex resolution supporting sample rates up to 192 KHz by the DAC and ADC. The STAC9202 SPDIF In/Out support sample rates of 96 KHz, 48 KHz and 44.1 KHz plus SPDIF_OUT supports 88.2 KHz. Additional sample rates are supported by the driver software.

The STAC9202 supports flexible configurations including switchable Headphone Out and Universal Jacks™ functionality for jack detection and re-tasking. The SPDIF interface provides connectivity to Consumer Electronic equipment like Dolby Digital decoders, powered speakers, mini disk drives or to a home entertainment system. All analog I/O pairs support LINE_IN, LINE_OUT and MIC.

Table of Contents

1. DESCRIPTION	9
1.1. Overview	9
1.2. Features	10
2. CHARACTERISTICS	11
2.1. Audio Fidelity	11
2.2. Electrical Specifications	11
2.3. STAC9202 5V Analog Performance Characteristics	13
2.4. STAC9202 4V Analog Performance Characteristics	14
2.5. STAC9202 3.3V Analog Performance Characteristics	14
2.6. Power Consumption	15
3. DETAILED DESCRIPTION	16
3.1. SPDIF Input	16
3.2. SPDIF Output	16
3.3. Digital Microphone Support	16
3.4. Mono Out	16
3.5. Headphone Drivers Restrictions	16
3.6. Universal Jacks	17
4. FUNCTIONAL BLOCK DIAGRAM	18
4.1. STAC9202	18
5. WIDGET DIAGRAM	19
5.1. STAC9202 Widget Diagram	19
5.2. STAC9202 Widget List	20
5.3. Root Node (NID = 0x00)	21
5.4. AFG Node (NID = 0x01)	22
5.5. DAC0Cnvtr Node (NID = 0x02)	37
5.6. ADC0Cnvtr Node (NID = 0x03)	41
5.7. SPDIFinCnvtr Node (NID = 0x04)	46
5.8. SPDIFoutCnvtr Node (NID = 0x05)	52
5.9. DAC0Mux Node (NID = 0x06)	57
5.10. DigInPin Node (NID = 0x07)	60
5.11. DigOutPin Node (NID = 0x08)	66
5.12. ADC0VolMux Node (NID = 0x09)	71
5.13. MasterVol Node (NID = 0x0E)	75
5.14. InPortMux Node (NID = 0x0F)	78
5.15. PortAPin Node (NID = 0x0A)	82
5.16. PortDPin Node (NID = 0x0D)	88
5.17. PortCPin Node (NID = 0x0C)	93
5.18. PortBPin Node (NID = 0x0B)	99
5.19. MonoOutPin Node (NID = 0x10)	105
5.20. CDPin Node (NID = 0x11)	110
5.21. MonoOutMix Node (NID = 0x12)	113
5.22. PCBeep Node (NID = 0x13)	115
5.23. ADC0InMux Node (NID = 0x14)	118
5.24. DigMicPin Node (NID = 0x15)	123
6. ORDERING INFORMATION	127
6.1. STAC9202 Options and Part Numbers	127
7. PIN INFORMATION	128
7.1. STAC9202 Pin Diagram	128
7.2. Pin Table for STAC9202	128
8. PACKAGE DRAWINGS	131
8.1. 48-Pin LQFP	131
9. SOLDER REFLOW PROFILE	132
9.1. Standard Reflow Profile Data	132

9.2. Pb Free Process - Package Classification Reflow Temperatures	133
10. REVISION HISTORY	134

List of Figures

Figure 1. STAC9202 Functional Block Diagram	18
Figure 2. STAC9202 Widget Diagram	19
Figure 3. STAC9202 Pin Diagram	128
Figure 4. 48-Pin LQFP Package Outline and Package Dimensions	131
Figure 5. Solder Reflow Profile	132

List of Tables

Table 1. Digital Power Consumption	15
Table 2. 5 V Analog Power Consumption	15
Table 3. High Definition Audio Widget	20
Table 4. Root PnpID Command Verb Format	21
Table 5. Root PnpID Command Response Format	21
Table 6. Root RevID Command Verb Format	21
Table 7. Root RevID Command Response Format	21
Table 8. Root NodeInfo Command Verb Format	22
Table 9. Root NodeInfo Command Response Format	22
Table 10. AFG Reset Command Verb Format	22
Table 11. AFG Reset Command Response Format	23
Table 12. AFG NodeInfo Command Verb Format	23
Table 13. AFG NodeInfo Command Response Format	23
Table 14. AFG Type Command Verb Format	24
Table 15. AFG Type Command Response Format	24
Table 16. AFG GrpCap Command Verb Format	24
Table 17. AFG GrpCap Command Response Format	24
Table 18. AFG FrmtCap Command Verb Format	25
Table 19. AFG FrmtCap Command Response Format	25
Table 20. AFG StreamCap Command Verb Format	26
Table 21. AFG StreamCap Command Response Format	26
Table 22. AFG PwrCap Command Verb Format	26
Table 23. AFG PwrCap Command Response Format	27
Table 24. AFG GPIOCap Command Verb Format	27
Table 25. AFG GPIOCap Command Response Format	28
Table 26. AFG OutAmpCap Command Verb Format	28
Table 27. AFG OutAmpCap Command Response Format	28
Table 28. AFG PwrState Command Verb Format	29
Table 29. AFG PwrState Command Response Format	29
Table 30. AFG UnsolResp Command Verb Format	29
Table 31. AFG UnsolResp Command Response Format	30
Table 32. AFG GPIO Command Verb Format	30
Table 33. AFG GPIO Command Response Format	30
Table 34. AFG GPIOEn Command Verb Format	31
Table 35. AFG GPIOEn Command Response Format	31
Table 36. AFG GPIODir Command Verb Format	32
Table 37. AFG GPIODir Command Response Format	32
Table 38. AFG GPIOWake Command Verb Format	33
Table 39. AFG GPIOWake Command Response Format	33

Table 40. AFG GPIOUnsolEn Command Verb Format	33
Table 41. AFG GPIOUnsolEn Command Response Format	34
Table 42. AFG GPIOSticky Command Verb Format	34
Table 43. AFG GPIOSticky Command Response Format	35
Table 44. AFG SysID Command Verb Format	35
Table 45. AFG SysID Command Response Format	36
Table 46. AFG DigMic Command Verb Format	36
Table 47. AFG DigMic Command Response Format	36
Table 48. DAC0Cnvtr Frmt Command Verb Format	37
Table 49. DAC0Cnvtr Frmt Command Response Format	37
Table 50. DAC0Cnvtr WCap Command Verb Format	38
Table 51. DAC0Cnvtr WCap Command Response Format	38
Table 52. DAC0Cnvtr PwrState Command Verb Format	39
Table 53. DAC0Cnvtr PwrState Command Response Format	39
Table 54. DAC0Cnvtr Stream Command Verb Format	40
Table 55. DAC0Cnvtr Stream Command Response Format	40
Table 56. ADC0Cnvtr Frmt Command Verb Format	41
Table 57. ADC0Cnvtr Frmt Command Response Format	41
Table 58. ADC0Cnvtr WCap Command Verb Format	42
Table 59. ADC0Cnvtr WCap Command Response Format	42
Table 60. ADC0Cnvtr ConnLen Command Verb Format	43
Table 61. ADC0Cnvtr ConnLen Command Response Format	43
Table 62. ADC0Cnvtr ConnLst Command Verb Format	44
Table 63. ADC0Cnvtr ConnLst Command Response Format	44
Table 64. ADC0Cnvtr ProcState Command Verb Format	44
Table 65. ADC0Cnvtr ProcState Command Response Format	44
Table 66. ADC0Cnvtr PwrState Command Verb Format	45
Table 67. ADC0Cnvtr PwrState Command Response Format	45
Table 68. ADC0Cnvtr Stream Command Verb Format	45
Table 69. ADC0Cnvtr Stream Command Response Format	45
Table 70. SPDIFinCnvtr Frmt Command Verb Format	46
Table 71. SPDIFinCnvtr Frmt Command Response Format	46
Table 72. SPDIFinCnvtr WCap Command Verb Format	47
Table 73. SPDIFinCnvtr WCap Command Response Format	47
Table 74. SPDIFinCnvtr FrmtCap Command Verb Format	48
Table 75. SPDIFinCnvtr FrmtCap Command Response Format	48
Table 76. SPDIFinCnvtr StreamCap Command Verb Format	49
Table 77. SPDIFinCnvtr StreamCap Command Response Format	50
Table 78. SPDIFinCnvtr ConnLen Command Verb Format	50
Table 79. SPDIFinCnvtr ConnLen Command Response Format	50
Table 80. SPDIFinCnvtr ConnLst Command Verb Format	50
Table 81. SPDIFinCnvtr ConnLst Command Response Format	51
Table 82. SPDIFinCnvtr Stream Command Verb Format	51
Table 83. SPDIFinCnvtr Stream Command Response Format	51
Table 84. SPDIFinCnvtr DigCtl Command Verb Format	51
Table 85. SPDIFinCnvtr DigCtl Command Response Format	52
Table 86. SPDIFoutCnvtr Frmt Command Verb Format	52
Table 87. SPDIFoutCnvtr Frmt Command Response Format	53
Table 88. SPDIFoutCnvtr WCap Command Verb Format	54
Table 89. SPDIFoutCnvtr WCap Command Response Format	54
Table 90. SPDIFoutCnvtr FrmtCap Command Verb Format	55
Table 91. SPDIFoutCnvtr FrmtCap Command Response Format	55
Table 92. SPDIFoutCnvtr StreamCap Command Verb Format	56
Table 93. SPDIFoutCnvtr StreamCap Command Response Format	56
Table 94. SPDIFoutCnvtr Stream Command Verb Format	56

Table 95. SPDIFoutCnvtr Stream Command Response Format	56
Table 96. SPDIFoutCnvtr DigCtl Command Verb Format	57
Table 97. SPDIFoutCnvtr DigCtl Command Response Format	57
Table 98. DAC0Mux WCap Command Verb Format	57
Table 99. DAC0Mux WCap Command Response Format	58
Table 100. DAC0Mux ConnLen Command Verb Format	58
Table 101. DAC0Mux ConnLen Command Response Format	59
Table 102. DAC0Mux ConnSel Command Verb Format	59
Table 103. DAC0Mux ConnSel Command Response Format	59
Table 104. DAC0Mux ConnLst Command Verb Format	59
Table 105. DAC0Mux ConnLst Command Response Format	59
Table 106. DAC0Mux LR Command Verb Format	60
Table 107. DAC0Mux LR Command Response Format	60
Table 108. DigInPin WCap Command Verb Format	60
Table 109. DigInPin WCap Command Response Format	61
Table 110. DigInPin Cap Command Verb Format	61
Table 111. DigInPin Cap Command Response Format	62
Table 112. DigInPin PwrState Command Verb Format	62
Table 113. DigInPin PwrState Command Response Format	62
Table 114. DigInPin Ctl Command Verb Format	63
Table 115. DigInPin Ctl Command Response Format	63
Table 116. DigInPin UnsolResp Command Verb Format	63
Table 117. DigInPin UnsolResp Command Response Format	64
Table 118. DigInPin Sense Command Verb Format	64
Table 119. DigInPin Sense Command Response Format	64
Table 120. DigInPin EAPD Command Verb Format	65
Table 121. DigInPin EAPD Command Response Format	65
Table 122. DigInPin Config Command Verb Format	65
Table 123. DigInPin Config Command Response Format	66
Table 124. DigOutPin WCap Command Verb Format	66
Table 125. DigOutPin WCap Command Response Format	66
Table 126. DigOutPin Cap Command Verb Format	67
Table 127. DigOutPin Cap Command Response Format	67
Table 128. DigOutPin ConnLen Command Verb Format	68
Table 129. DigOutPin ConnLen Command Response Format	68
Table 130. DigOutPin ConnSel Command Verb Format	69
Table 131. DigOutPin ConnSel Command Response Format	69
Table 132. DigOutPin ConnLst Command Verb Format	69
Table 133. DigOutPin ConnLst Command Response Format	69
Table 134. DigOutPin Ctl Command Verb Format	70
Table 135. DigOutPin Ctl Command Response Format	70
Table 136. DigOutPin Config Command Verb Format	70
Table 137. DigOutPin Config Command Response Format	70
Table 138. ADC0VolMux VolRight Command Verb Format	71
Table 139. ADC0VolMux VolRight Command Response Format	71
Table 140. ADC0VolMux VolLeft Command Verb Format	72
Table 141. ADC0VolMux VolLeft Command Response Format	72
Table 142. ADC0VolMux WCap Command Verb Format	72
Table 143. ADC0VolMux WCap Command Response Format	72
Table 144. ADC0VolMux OutAmpCap Command Verb Format	73
Table 145. ADC0VolMux OutAmpCap Command Response Format	73
Table 146. ADC0VolMux ConnLen Command Verb Format	74
Table 147. ADC0VolMux ConnLen Command Response Format	74
Table 148. ADC0VolMux ConnLst Command Verb Format	74
Table 149. ADC0VolMux ConnLst Command Response Format	74

Table 150. MasterVol Right Command Verb Format	75
Table 151. MasterVol Right Command Response Format	75
Table 152. MasterVol Left Command Verb Format	75
Table 153. MasterVol Left Command Response Format	75
Table 154. MasterVol WCap Command Verb Format	76
Table 155. MasterVol WCap Command Response Format	76
Table 156. MasterVol ConnLen Command Verb Format	77
Table 157. MasterVol ConnLen Command Response Format	77
Table 158. MasterVol ConnLst Command Verb Format	77
Table 159. MasterVol ConnLst Command Response Format	77
Table 160. InPortMux VolRight Command Verb Format	78
Table 161. InPortMux VolRight Command Response Format	78
Table 162. InPortMux VolLeft Command Verb Format	78
Table 163. InPortMux VolLeft Command Response Format	78
Table 164. InPortMux WCap Command Verb Format	78
Table 165. InPortMux WCap Command Response Format	79
Table 166. InPortMux ConnLen Command Verb Format	79
Table 167. InPortMux ConnLen Command Response Format	80
Table 168. InPortMux AmpCap Command Verb Format	80
Table 169. InPortMux AmpCap Command Response Format	80
Table 170. InPortMux ConnSel Command Verb Format	81
Table 171. InPortMux ConnSel Command Response Format	81
Table 172. InPortMux ConnLst0 Command Verb Format	81
Table 173. InPortMux ConnLst0 Command Response Format	81
Table 174. InPortMux ConnLst4 Command Verb Format	81
Table 175. InPortMux ConnLst4 Command Response Format	82
Table 176. PortAPin WCap Command Verb Format	82
Table 177. PortAPin WCap Command Response Format	82
Table 178. PortAPin Cap Command Verb Format	83
Table 179. PortAPin Cap Command Response Format	83
Table 180. PortAPin ConnLen Command Verb Format	84
Table 181. PortAPin ConnLen Command Response Format	84
Table 182. PortAPin ConnLst Command Verb Format	84
Table 183. PortAPin ConnLst Command Response Format	84
Table 184. PortAPin Ctl Command Verb Format	85
Table 185. PortAPin Ctl Command Response Format	85
Table 186. PortAPin UnsolResp Command Verb Format	85
Table 187. PortAPin UnsolResp Command Response Format	85
Table 188. PortAPin Sense Command Verb Format	86
Table 189. PortAPin Sense Command Response Format	86
Table 190. PortAPin Config Command Verb Format	87
Table 191. PortAPin Config Command Response Format	87
Table 192. PortDPin WCap Command Verb Format	88
Table 193. PortDPin WCap Command Response Format	88
Table 194. PortDPin Cap Command Verb Format	89
Table 195. PortDPin Cap Command Response Format	89
Table 196. PortDPin ConnLen Command Verb Format	89
Table 197. PortDPin ConnLen Command Response Format	90
Table 198. PortDPin ConnLst Command Verb Format	90
Table 199. PortDPin ConnLst Command Response Format	90
Table 200. PortDPin Ctl Command Verb Format	90
Table 201. PortDPin Ctl Command Response Format	91
Table 202. PortDPin UnsolResp Command Verb Format	91
Table 203. PortDPin UnsolResp Command Response Format	91
Table 204. PortDPin Sense Command Verb Format	92

Table 205. PortDPin Sense Command Response Format	92
Table 206. PortDPin Config Command Verb Format	92
Table 207. PortDPin Config Command Response Format	93
Table 208. PortCPin WCap Command Verb Format	93
Table 209. PortCPin WCap Command Response Format	93
Table 210. PortCPin Cap Command Verb Format	94
Table 211. PortCPin Cap Command Response Format	94
Table 212. PortCPin ConnLen Command Verb Format	95
Table 213. PortCPin ConnLen Command Response Format	95
Table 214. PortCPin ConnLst Command Verb Format	96
Table 215. PortCPin ConnLst Command Response Format	96
Table 216. PortCPin Ctl Command Verb Format	96
Table 217. PortCPin Ctl Command Response Format	96
Table 218. PortCPin UnsolResp Command Verb Format	97
Table 219. PortCPin UnsolResp Command Response Format	97
Table 220. PortCPin Sense Command Verb Format	98
Table 221. PortCPin Sense Command Response Format	98
Table 222. PortCPin Config Command Verb Format	98
Table 223. PortCPin Config Command Response Format	99
Table 224. PortBPin WCap Command Verb Format	99
Table 225. PortBPin WCap Command Response Format	99
Table 226. PortBPin Cap Command Verb Format	100
Table 227. PortBPin Cap Command Response Format	100
Table 228. PortBPin ConnLen Command Verb Format	101
Table 229. PortBPin ConnLen Command Response Format	101
Table 230. PortBPin ConnLst Command Verb Format	102
Table 231. PortBPin ConnLst Command Response Format	102
Table 232. PortBPin Ctl Command Verb Format	102
Table 233. PortBPin Ctl Command Response Format	102
Table 234. PortBPin UnsolResp Command Verb Format	103
Table 235. PortBPin UnsolResp Command Response Format	103
Table 236. PortBPin Sense Command Verb Format	104
Table 237. PortBPin Sense Command Response Format	104
Table 238. PortBPin Config Command Verb Format	104
Table 239. PortBPin Config Command Response Format	105
Table 240. MonoOutPin Vol Command Verb Format	105
Table 241. MonoOutPin Vol Command Response Format	105
Table 242. MonoOutPin WCap Command Verb Format	106
Table 243. MonoOutPin WCap Command Response Format	106
Table 244. MonoOutPin Cap Command Verb Format	107
Table 245. MonoOutPin Cap Command Response Format	107
Table 246. MonoOutPin ConnLen Command Verb Format	108
Table 247. MonoOutPin ConnLen Command Response Format	108
Table 248. MonoOutPin ConnLst Command Verb Format	108
Table 249. MonoOutPin ConnLst Command Response Format	108
Table 250. MonoOutPin Ctl Command Verb Format	109
Table 251. MonoOutPin Ctl Command Response Format	109
Table 252. MonoOutPin Config Command Verb Format	109
Table 253. MonoOutPin Config Command Response Format	109
Table 254. CDPin WCap Command Verb Format	110
Table 255. CDPin WCap Command Response Format	110
Table 256. CDPin Cap Command Verb Format	111
Table 257. CDPin Cap Command Response Format	111
Table 258. CDPin Ctl Command Verb Format	112
Table 259. CDPin Ctl Command Response Format	112

Table 260. CDPin Config Command Verb Format	112
Table 261. CDPin Config Command Response Format	113
Table 262. MonoOutMix WCap Command Verb Format	113
Table 263. MonoOutMix WCap Command Response Format	114
Table 264. MonoOutMix ConnLen Command Verb Format	114
Table 265. MonoOutMix ConnLen Command Response Format	115
Table 266. MonoOutMix ConnLst Command Verb Format	115
Table 267. MonoOutMix ConnLst Command Response Format	115
Table 268. PCBeep Vol Command Verb Format	115
Table 269. PCBeep Vol Command Response Format	116
Table 270. PCBeep WCap Command Verb Format	116
Table 271. PCBeep WCap Command Response Format	116
Table 272. PCBeep OutAmpCap Command Verb Format	117
Table 273. PCBeep OutAmpCap Command Response Format	117
Table 274. PCBeep Gen Command Verb Format	117
Table 275. PCBeep Gen Command Response Format	118
Table 276. ADC0InMux WCap Command Verb Format	118
Table 277. ADC0InMux WCap Command Response Format	118
Table 278. ADC0InMux ConnLen Command Verb Format	119
Table 279. ADC0InMux ConnLen Command Response Format	119
Table 280. ADC0InMux ConnSel Command Verb Format	120
Table 281. ADC0InMux ConnSel Command Response Format	120
Table 282. ADC0InMux ConnLst Command Verb Format	120
Table 283. ADC0InMux ConnLst Command Response Format	120
Table 284. ADC0InMux LR Command Verb Format	121
Table 285. ADC0InMux LR Command Response Format	121
Table 286. ADC0InMux OutAmpCap Command Verb Format	121
Table 287. ADC0InMux OutAmpCap Command Response Format	121
Table 288. ADC0InMux VolRight Command Verb Format	122
Table 289. ADC0InMux VolRight Command Response Format	122
Table 290. ADC0InMux VolLeft Command Verb Format	122
Table 291. ADC0InMux VolLeft Command Response Format	122
Table 292. DigMicPin WCap Command Verb Format	123
Table 293. DigMicPin WCap Command Response Format	123
Table 294. DigMicPin Cap Command Verb Format	124
Table 295. DigMicPin Cap Command Response Format	124
Table 296. DigMicPin Ctl Command Verb Format	125
Table 297. DigMicPin Ctl Command Response Format	125
Table 298. DigMicPin Config Command Verb Format	125
Table 299. DigMicPin Config Command Response Format	125

1. DESCRIPTION

1.1. Overview

The STAC9202 is a high fidelity, 2-channel, audio CODEC compliant with the High Definition Audio (HD Audio) specification defined by Intel. The STAC9202 provides high quality, HD Audio capability to notebook and cost sensitive desktop PC applications.

The STAC9202 incorporates IDT's proprietary $\Sigma\Delta$ technology to achieve a DAC SNR of 100 dB. The higher performance and quality of IDT's audio solutions brings consumer electronics level performance to the notebook, desktop and media center PC.

The STAC9202 provides stereo, 24-bit, full duplex resolution supporting sample rates up to 192 KHz by the DAC and ADC. The STAC9202 SPDIF_IN/SPDIF_OUT support sample rates of 96 KHz, 48 KHz and 44.1 KHz plus SPDIF_OUT supports 88.2 KHz. Additional sample rates are supported by the driver software.

The STAC9202 supports flexible configurations including switchable Headphone Out and Universal Jacks™ functionality for jack detection and re-tasking. The SPDIF interface provides connectivity to Consumer Electronic equipment like Dolby Digital decoders, powered speakers, mini disk drives or to a home entertainment system. All analog I/O pairs support LINE_IN, LINE_OUT and MIC.

MIC inputs can be programmed with 0/10/20/30/40dB boost. For more advanced configurations, the STAC9202 has four General Purpose I/O (GPIO) pins. The STAC9202 also provides a single ended CD input for compatibility with DRM solutions and to support legacy OS issues.

The STAC9202 integrates a headphone amplifier which is available on Ports A and D. The headphone amplifier is switchable between these two outputs for increased flexibility, enhanced user experience, and reduced implementation costs.

The Universal Jack capabilities allow the CODECs to detect when audio devices are connected to the CODEC, and allow the CODECs to be reconfigured to support these devices, regardless of which port they are plugged into. SPDIF input sensing is also supported. The fully parametric IDT SoftEQ can be initiated upon headphone jack insertion and removal for protection of notebook speakers.

Note: The Jack Detect circuit and component selection are critical for accurate detection of audio jacks on individual ports. Please see the IDT STAC9202 reference design for circuit implementation details.

The STAC9202 operates with a 3.3 V digital supply and a 3.3 V, 4 V and 5 V analog supply.

The STAC9202 is available in a 48-pin LQFP Environmental (ROHS) package.

The STAC9202 implements a direct interface to two digital microphones, supporting advanced beam forming applications resulting in increased quality of applications requiring voice input.

1.2. Features

- High-integration HD Audio Product
 - Two-channel PC Audio CODEC
 - Dual Digital Microphone interface
- Two-Channel DACs and ADCs with 24-bit sample resolution
 - High performance $\Sigma\Delta$ technology
 - Sample rates up to 192 KHz
 - 100dB DAC SNR
- Integrated Headphone Amps
- Stereo Analog Microphone
 - Supports Stereo Mic
 - Microphone Boost 0, 10, 20, 30, 40dB
- Dual Digital Microphone Interface optimized for use with Akustica Digital Microphones
- S/PDIF In and Out
- Universal Jacks™ Functionality for jack retasking
- Adjustable VREF Out
- Digital PC Beep to all outputs
- +3.3 V, 4 V and +5 V analog power supply options
- 48-pin LQFP Environmental Package

2. CHARACTERISTICS

2.1. Audio Fidelity

DAC SNR: 100dB

ADC SNR: 90dB

2.2. Electrical Specifications

2.2.1. Absolute Maximum Ratings

Stresses above the ratings listed below can cause permanent damage to the STAC9202. These ratings, which are standard values for IDT commercially rated parts, are stress ratings only. Functional operation of the device at these or any other conditions above those indicated in the operational sections of the specifications is not implied. Exposure to absolute maximum rating conditions for extended periods can affect product reliability. Electrical parameters are guaranteed only over the recommended operating temperature range.

Item	Pin	Maximum Rating
Analog maximum supply voltage	AVdd	6 Volts
Digital maximum supply voltage	DVdd	5.5 Volts
VREFOUT output current		5 mA
Voltage on any pin relative to ground		Vss - 0.3 V to Vdd + 0.3 V
Operating temperature		0°C to +70°C
Storage temperature		-55 °C to +125 °C
Soldering temperature		260 °C for 10 seconds * Soldering temperature information for all available packages begins on page 132.

2.2.2. Recommended Operation Conditions

Parameter		Min.	Typ.	Max.	Units
Power Supply Voltage	Digital - 3.3 V	3.135	3.3	3.465	V
	Analog - 3.3 V	3.135	3.3	3.465	V
(Note: The +4 V Analog voltage is supported by the +5 V version of the STAC9202.)	Analog - 4 V	3.8	4	4.2	V
	Analog - 5 V	4.75	5	5.25	V
Ambient Operating Temperature		0		+70	°C
Case Temperature	T _{case} (48-LQFP)			+90	°C

ESD: The STAC9202 is an ESD (electrostatic discharge) sensitive device. The human body and test equipment can accumulate and discharge electrostatic charges up to 4000 Volts without detection. Even though the STAC9202 implements internal ESD protection circuitry, proper ESD precautions should be followed to avoid damaging the functionality or performance.

2.3. STAC9202 5V Analog Performance Characteristics

($T_{\text{ambient}} = 25\text{ }^{\circ}\text{C}$, $AV_{\text{dd}} = 5.0\text{ V} \pm 5\%$, $DV_{\text{dd}} = 3.3\text{ V} \pm 5\%$, $AV_{\text{ss}} = DV_{\text{ss}} = 0\text{ V}$; 1 KHz input sine wave; Sample Frequency = 48 KHz; 0 dB = 1 VRMS, 10 K Ω / 50 pF load, Testbench Characterization BW: 20 Hz – 20 KHz, 0dB settings on all gain stages)

Min and Max performance targets are not included here. Specific system characteristics, such as layout, routing and external CODEC component selection influence the performance of the CODEC. To receive min/max levels for your system, please send us a unit and IDT will perform a full audio test suite and provide you with the results.

Parameter	Min	Typ	Max	Unit
Full Scale Input Voltage:				
All Analog Inputs with out boost	-	1.00	-	Vrms
All Analog Inputs with boost (Note 1)	-	0.03	-	Vrms
Full Scale Output:				
PCM (DAC) to All Analog Outputs	-	1.00	-	Vrms
HEADPHONE_OUT (32 Ω load) per channel	-	50	-	mWpk
Dynamic Range: -60dB signal level (Note 2)				
PCM to All Analog Outputs	-	99	-	dB
All Analog Inputs to A/D (1 VRMS Input Referenced)	-	88	-	dB
Analog Frequency Response (Note 3)	10	-	30,000	Hz
Total Harmonic Distortion + Noise (-3dB): (Note 4)				
PCM to All Analog Outputs	-	-90	-	dB
All Analog Inputs to A/D (-3dBV input Level)	-	-87	-	dB
HEADPHONE_OUT (32 Ω load)	-	-87	-	dB
HEADPHONE_OUT (10 K Ω load)	-	-90	-	dB
SNR (idle channel) (Note 5)				
DAC to All Analog Outputs	-	100	-	dB
All Analog Inputs to A/D with High Pass Filter enabled	-	89	-	dB
A/D & D/A Digital Filter Pass Band (Note 6)	20	-	19,200	Hz
A/D & D/A Digital Filter Transition Band	19,200	-	28,800	Hz
A/D & D/A Digital Filter Stop Band	28,800	-	-	Hz
A/D & D/A Digital Filter Stop Band Rejcn (Note 7)	-100	-	-	dB
DAC Out-of-Band Rejection (Note 8)	-55	-	-	dB
Group Delay (48 KHz sample rate)	-	-	1	ms
Power Supply Rejection Ratio (1 KHz)	-	-70	-	dB
Power Supply Rejection Ratio (20 KHz)	-	-40	-	dB
Any Analog Input to ADC (10 KHz Signal Frequency) Crosstalk	-	-90	-	dB
Any Analog Input to ADC (1 KHz Signal Frequency) Crosstalk	-	-90	-	dB

Parameter	Min	Typ	Max	Unit
Spurious Tone Rejection	-	-100	-	dB
Attenuation, Gain Step Size ANALOG	-	1.5	-	dB
Attenuation, Gain Step Size DIGITAL	-	0.75	-	dB
Input Impedance	-	50	-	KW
Input Capacitance	-	15	-	pF
VREFout	-	0.5 X AVdd	-	V
VREF	-	0.45X AVdd	0.5	V
Interchannel Gain Mismatch ADC	-	-	0.5	dB
Interchannel Gain Mismatch DAC	-	-	-	dB
Gain Drift	-	100	-	ppm/°C
DAC Offset Voltage	-	5	10	mV
Deviation from Linear Phase	-	10	1	deg.
All Analog Outputs Load Resistance	-	10	-	KΩ
All Analog Outputs Load Capacitance	-	-	50	pF
HEADPHONE_OUT Load Resistance	-	32	-	Ω
HEADPHONE_OUT Load Capacitance	-	100	-	pF
Mute Attenuation	-	-	-	dB
PLL lock time	-	96	200	μsec
PLL (or HD Audio Bit CLK) 24.576 MHz clock jitter	-	100	300	psec

1. With +30 dB Boost on, 1.00 Vrms with Boost off.
2. Ratio of Full Scale signal to noise output with -60dB signal, measured "A weighted" over a 20 Hz to a 20 KHz bandwidth.
3. ± 1dB limits for Line Output & 0 dB gain, at -20dBV
4. Amplitude of THD+N, measured with A-weighting filter, over 20 Hz to 20 KHz bandwidth.
5. Ratio of Full Scale signal to idle channel noise output is measured "A weighted" over a 20 Hz to a 20 KHz bandwidth. (AES17-1991 Idle Channel Noise or EIAJ CP-307 Signal-to-noise Ratio).
6. Peak-to-Peak Ripple over Passband meets ± 0.25dB limits, 48 KHz Sample Frequency.
7. Stop Band rejection determines filter requirements. Out-of-Band rejection determines audible noise.
8. The integrated Out-of-Band noise generated by the DAC process, during normal PCM audio playback, over a bandwidth 28.8 to 100 KHz, with respect to a 1 Vrms DAC output.

2.4. STAC9202 4V Analog Performance Characteristics

If you are interested in using the STAC9202 at 4V Analog, please contact IDT for more information.

2.5. STAC9202 3.3V Analog Performance Characteristics

If you are interested in using the STAC9202 at 3.3V Analog, please contact IDT for more information.

2.6. Power Consumption

2.6.1. Digital

Table 1. Digital Power Consumption

Power State	Typical	Max	units
D0	20	25	mA
D1	14	17	mA
D2	14	17	mA
D3	14	17	mA

2.6.2. 5V Analog

Table 2. 5 V Analog Power Consumption

Power State	Typical	Max	units
D0	30	36	mA
D1	12	26	mA
D2	12	26	mA
D3	11	26	mA

3. DETAILED DESCRIPTION

3.1. SPDIF Input

SPDIF_IN can operate at 44.1 KHz, 48 KHz or 96 KHz and implements internal Jack Sensing. A sophisticated digital PLL allows automatic rate detection and accurate data recovery. The ability to accept consumer SPDIF voltage levels directly eliminates the need for costly external receiver ICs. Advanced features such as record slot select and SPDIF_IN routing to the DAC allows for simultaneous record and play.

3.2. SPDIF Output

SPDIF_OUT can operate at 44.1 KHz, 48 KHz, 88.2 KHz and 96 KHz as defined in the Intel High Definition Audio Specification with resolutions up to 24 bits. This insures compatibility with all consumer audio gear and allows for convenient integration into home theater systems and media center PCs.

3.3. Digital Microphone Support

The STAC9202 has a three-pin digital microphone interface that accepts high-rate, single-bit data streams from two digital microphones. Each microphone requires only one data line, and both microphones share a single clock line. This robust digital interface gives designers the flexibility to place the microphones in the optimum physical location on a system (such as along the top of the screen bezel) and use a simple, 3-wire ribbon cable to directly connect the microphones to the STAC9202 CODEC.

3.4. Mono Out

The MONO Output is connected to pin 37 and has independent volume and mute control (see the Widget listing for details). The MONO Output derives its input from the output of the summing node that drives PORT A and PORT D. The following analog signals feed the summing amplifier that feeds the MONO Out summing amplifier:

- DAC Output: When enabled, both DAC Outputs are summed together.
- Analog PC BEEP: Source from Pin 12
- ADC Input: Stereo analog feed into the stereo ADC input.

The signals of the stereo channels from the DAC are combined into a single analog signal with a -6dB degradation in signal strength.

3.5. Headphone Drivers Restrictions

It is not recommended that users operate both Port A and Port D as headphone drivers simultaneously. The operation of the two ports as headphone drivers degrades the signal quality of both outputs.¹

Note: 1) Headphone capabilities are on Port A (pins 39/41) and Port D (pins 35/36). Do NOT put headphone loads on both sets of pins at the same time.

3.6. Universal Jacks

IDT's Universal Jacks technology allows for flexibility in board design and implementation.

On the STAC9202, only one function can be selected at a time. A set of pins cannot be set as input and output at the same time. However, the selected function can be changed at any time.

For the STAC9202 the Universal Jacks capabilities are as follows

- All of the STAC9202 ports support:
 - Line Out
 - Line In
 - Mic with 0/10/20/30/40² dB Mic Boost
- Ports A and D also support:
 - Headphone Out¹

Note: 1) Headphone capabilities are on Port A (pins 39/41) and Port D (pins 35/36). Do NOT put headphone loads on both sets of pins at the same time.

Note: 2) When the 40dB mic boost feature is enabled, additional gain increases greater than 6dB may result in significant audio quality degradation of the microphone audio input. In particular, when the 40dB MIC boost is active, the SNR, THD+N and DC offset will significantly degrade regardless of the input signal level.

4. FUNCTIONAL BLOCK DIAGRAM

4.1. STAC9202

Figure 1. STAC9202 Functional Block Diagram

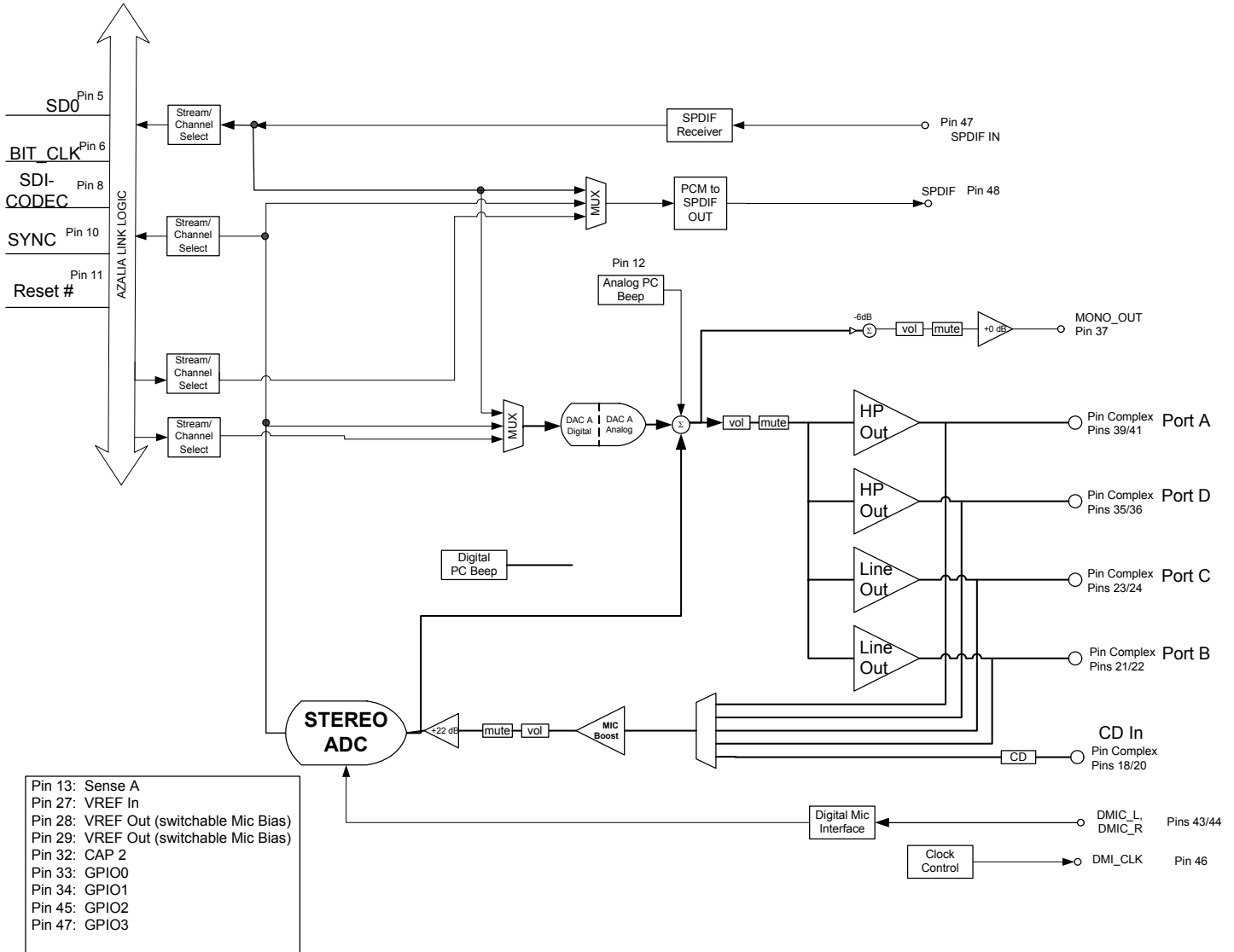

5. WIDGET DIAGRAM

5.1. STAC9202 Widget Diagram

Figure 2. STAC9202 Widget Diagram

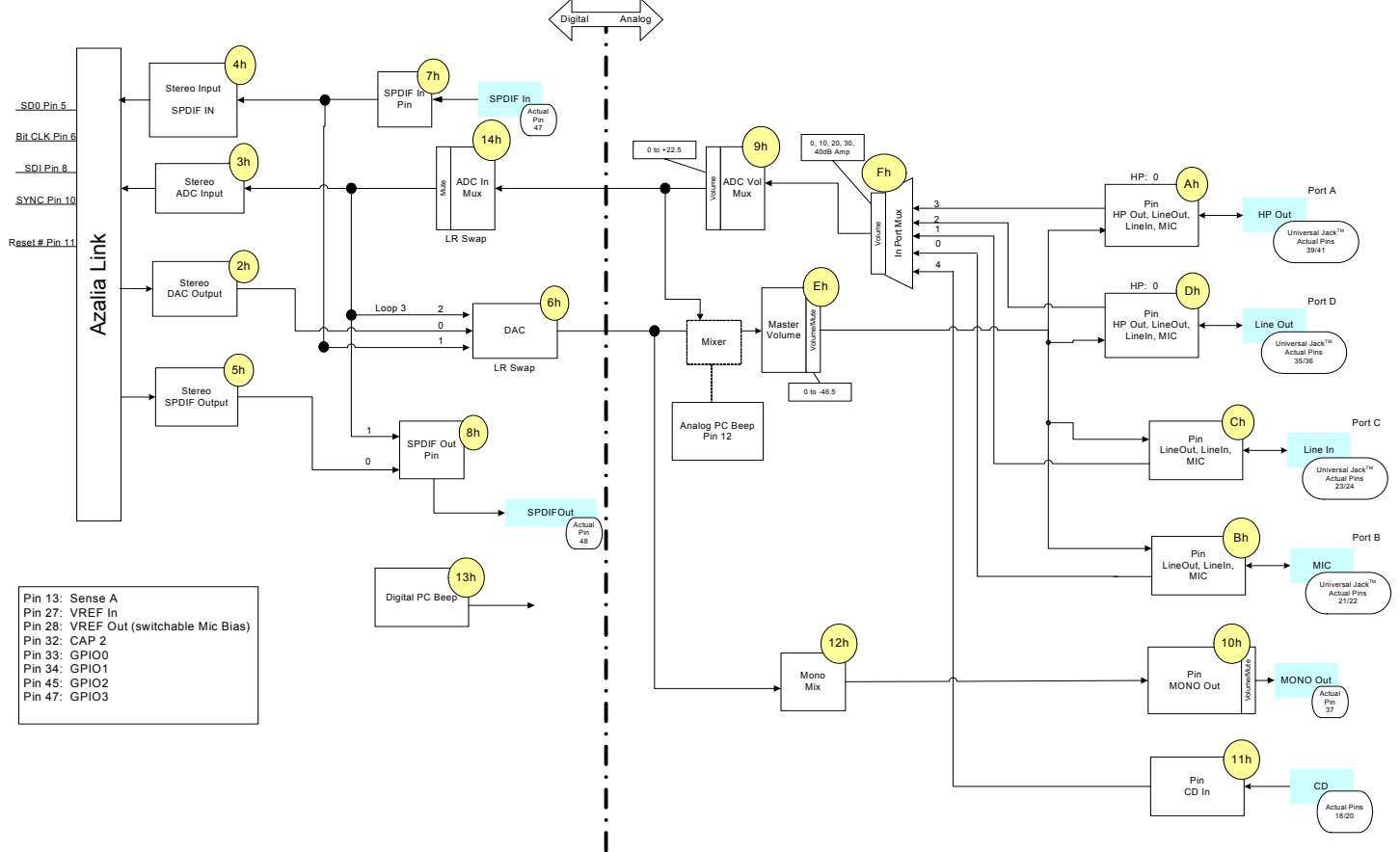

5.2. STAC9202 Widget List

Table 3. High Definition Audio Widget

ID	Widget Name	Description
00h	Root	Root Node
01h	Audio Function Group	Audio Function Group
02h	DAC0	Stereo Output to DAC
03h	ADC0	Stereo Input from ADC
04h	SPDIF_IN	Stereo Input for SPDIF_IN
05h	SPDIF_OUT	Stereo Output for SPDIF_OUT
06h	DAC0Mux	DAC Mux and Boost for outputs for DAC
07h	DigPin1	Pin Widget for SPDIF_IN pin 47
08h	DigPin0	Pin Widget for SPDIF_OUT pin 48
09h	ADC0VolMux	ADC0 Volume
0Eh	MasterVolume	Master Volume Controls
0Fh	InPortMux	Port Mux for ADC0
0Ah	Port A	Port A Pin Widget (Pins 39/41, configurable as HP, Line In, Line Out, Mic)
0Dh	Port D	Port D Pin Widget (Pins 35/36, configurable as HP, Line In, Line Out, Mic)
0Ch	Port C	Port C Pin Widget (Pins 23/24, configurable as Line Out, Mic)
0Bh	Port B	Port B Pin Widget (Pins 21/22, configurable as Line Out, Mic)
10h	MonoOut	Mono Output from DAC
11h	CD	CD Pin Widget pins 18/19/20
12h	MonoOutMix	Mixer for Mono Output
13h	Digital PC Beep	Digital PC Beep
14h	ADC0InMux	Input Mux for ADC converter
15h	DigMicPin	Pin Widget for Digital Microphone (Pins 43/44/46 configurable as a Mic)

5.3. Root Node (NID = 0x00)

5.3.1. Root PnpID_

Table 4. Root PnpID Command Verb Format

	Verb ID	Payload	Response
Get	F00	00	See bitfield table

Table 5. Root PnpID Command Response Format

Bit	Bitfield Name	RW	Reset	Description
[31:16]	Vendor	R	0x8384	Vendor ID = 8384h
[15:0]	Device	R	0x7630	Device ID for: STAC9202 = 7632

5.3.2. Root RevID

Table 6. Root RevID Command Verb Format

	Verb ID	Payload	Response
Get	F00	02	See bitfield table

Table 7. Root RevID Command Response Format

Bit	Bitfield Name	RW	Reset	Description
[31:24]	Rsvd	R	0x00	Reserved
[23:20]	Major	R	0x1	Major rev number of compliant HD Audio specification
[19:16]	Minor	R	0x0	Minor rev number of compliant HD Audio specification
[15:8]	Vendor	R	0x01	Vendor rev number for this device ID
[7:0]	Stepping	R	0x01	Vendor stepping number within the given Vendor RevID

5.3.3. Root NodeInfo

Table 8. Root NodeInfo Command Verb Format

	Verb ID	Payload	Response
Get	F00	04	See bitfield table

Table 9. Root NodeInfo Command Response Format

Bit	Bitfield Name	RW	Reset	Description
[31:24]	Rsvd2	R	0x00	Reserved
[23:16]	StartNID	R	0x01	Starting node number (NID) of first function group
[15:8]	Rsvd1	R	0x00	Reserved
[7:0]	TotalNodes	R	0x01	Total number of nodes

5.4. AFG Node (NID = 0x01)

5.4.1. AFG Reset

Table 10. AFG Reset Command Verb Format

	Verb ID	Payload	Response
Get	7FF	00	See bitfield table
Set1	7FF	See bits [7:0] of bitfield table	0000_0000h

Table 11. AFG Reset Command Response Format

Bit	Bitfield Name	RW	Reset	Description
[31:0]	Response	R	0x0	Reserved. Overlaps Execute.
[0]	Execute	W	0x0	Function Reset. Function Group reset is executed when the Set verb 7FF is written with 8-bit payload of 00h. The CODEC should issue a response to acknowledge receipt of the verb, and then reset the affected Function Group and all associated widgets to their power-on reset values. Some controls such as Configuration Default controls should not be reset. Overlaps Response.

5.4.2. AFG NodeInfo

Table 12. AFG NodeInfo Command Verb Format

	Verb ID	Payload	Response
Get	F00	04	See bitfield table

Table 13. AFG NodeInfo Command Response Format

Bit	Bitfield Name	RW	Reset	Description
[31:24]	Rsvd2	R	0x0	Reserved
[23:16]	StartNID	R	0x02	Starting node number for function group subordinate nodes.
[15:8]	Rsvd1	R	0x0	Reserved
[7:0]	TotalNodes	R	0x14	Total number of nodes. 14h = STAC9202

5.4.3. AFG Type

Table 14. AFG Type Command Verb Format

	Verb ID	Payload	Response
Get	F00	05	See bitfield table

Table 15. AFG Type Command Response Format

Bit	Bitfield Name	RW	Reset	Description
[31:9]	Rsvd	R	0x0	Reserved
[8]	Unsol	R	0x1	This node is capable of generating an unsolicited response, and will respond to the Unsolicited Response verb (Verb ID 708h).
[7:0]	NodeType	R	0x01	Node type = Audio Function Group

5.4.4. AFG GrpCap

Table 16. AFG GrpCap Command Verb Format

	Verb ID	Payload	Response
Get	F00	08	See bitfield table

Table 17. AFG GrpCap Command Response Format

Bit	Bitfield Name	RW	Reset	Description
[31:17]	Rsvd3	R	0x0	Reserved
[16]	BeepGen	R	0x1	Optional Beep Generator is present
[15:12]	Rsvd2	R	0x0	Reserved
[11:8]	InputDelay	R	0xD	Typical latency = 13 frames. Number of samples between when the sample is received as an analog signal at the pin and when the digital representation is transmitted on the HD Audio link.

Table 17. AFG GrpCap Command Response Format

Bit	Bitfield Name	RW	Reset	Description
[7:4]	Rsvd1	R	0x0	Reserved
[3:0]	OutputDelay	R	0xD	Typical latency = 13 frames. Number of samples between when the signal is received from the HD Audio link and when it appears as an analog signal at the pin.

5.4.5. AFG FrmtCap

Table 18. AFG FrmtCap Command Verb Format

	Verb ID	Payload	Response
Get	F00	0A	See bitfield table

Table 19. AFG FrmtCap Command Response Format

Bit	Bitfield Name	RW	Reset	Description
[31:21]	Rsvd2	R	0x0	Reserved
[20]	B32	R	0x0	32 bit audio formats are NOT supported
[19]	B24	R	0x1	24 bit audio formats are supported
[18]	B20	R	0x1	20 bit audio formats are supported
[17]	B16	R	0x1	16 bit audio formats are supported
[16]	B8	R	0x0	8 bit audio formats are NOT supported
[15:12]	Rsvd1	R	0x0	Reserved
[11]	R12	R	0x0	384 KHz rate (8/1*48 KHz) NOT supported
[10]	R11	R	0x1	192.0 KHz rate (4/1*48 KHz) supported
[9]	R10	R	0x1	176.4 KHz rate (4/1*44.1 KHz) supported
[8]	R9	R	0x1	96.0 KHz rate (2/1*48 KHz) supported
[7]	R8	R	0x1	88.2 KHz rate (2/1*44.1 KHz) supported

Table 19. AFG FrmtCap Command Response Format

Bit	Bitfield Name	RW	Reset	Description
[6]	R7	R	0x1	48.0 KHz rate supported (REQUIRED)
[5]	R6	R	0x1	44.1 KHz rate supported
[4]	R5	R	0x0	32.0 KHz rate (2/3*48 KHz) NOT supported
[3]	R4	R	0x0	22.05 KHz rate (1/2*44.1 KHz) NOT supported
[2]	R3	R	0x0	16.0 KHz rate (1/3*48 KHz) NOT supported
[1]	R2	R	0x0	11.025 KHz rate (1/4*44.0 KHz) NOT supported
[0]	R1	R	0x0	8.0 KHz rate (1/6*48 KHz) NOT supported

5.4.6. AFG StreamCap

Table 20. AFG StreamCap Command Verb Format

	Verb ID	Payload	Response
Get	F00	0B	See bitfield table

Table 21. AFG StreamCap Command Response Format

Bit	Bitfield Name	RW	Reset	Description
[31:3]	Rsvd	R	0x0	Reserved
[2]	NonPCM	R	0x0	No support for non-PCM (AC3) data.
[1]	Float32	R	0x0	No support for single-precision floating-point data.
[0]	PCM	R	0x1	PCM-formatted data supported.

5.4.7. AFG PwrCap

Table 22. AFG PwrCap Command Verb Format

	Verb ID	Payload	Response
Get	F00	0F	See bitfield table

Table 23. AFG PwrCap Command Response Format

Bit	Bitfield Name	RW	Reset	Description
[31:4]	Rsvd	R	0x0	Reserved
[3]	D3	R	0x1	Power State D3 is supported. Allows for lowest possible power consuming state under software control (and still properly respond to a subsequent Power State command).
[2]	D2	R	0x1	Power State D2 is supported. Allows for lowest possible power consuming state from which it can return to fully on state within 10 ms.
[1]	D1	R	0x1	Power State D1 is supported. Allows for lowest possible power consuming state from which it can return to fully on state within 10 ms, excepting analog pass-through circuits which must remain fully on.
[0]	D0	R	0x1	Power State D0 is supported. Node power state is fully on.

5.4.8. AFG GPIOCap

Table 24. AFG GPIOCap Command Verb Format

	Verb ID	Payload	Response
Get	F00	11	See bitfield table

Table 25. AFG GPIOCap Command Response Format

Bit	Bitfield Name	RW	Reset	Description
[31]	GPIWake	R	0x1	Wake capability. Assuming the Wake Enable Mask controls are enabled, GPIOs configured as inputs can cause a wake (generate a Status Change event on the link) when there is a change in level on the pin.
[30]	GPIUnsol	R	0x1	Unsolicited Response capability. Assuming the Unsolicited Enable Mask controls are enabled, GPIOs configured as inputs can generate an Unsolicited Response on the link when there is a change in level on the pin.
[29:24]	Rsvd	R	0x0	Reserved
[23:16]	NumGPIs	R	0x00	Number of GPI pins supported
[15:8]	NumGPOs	R	0x00	Number of GPO pins supported
[7:0]	NumGPIOs	R	0x04	Number of GPIO pins supported

5.4.9. AFG OutAmpCap

Table 26. AFG OutAmpCap Command Verb Format

	Verb ID	Payload	Response
Get	F00	12	See bitfield table

Table 27. AFG OutAmpCap Command Response Format

Bit	Bitfield Name	RW	Reset	Description
[31]	Mute	R	0x1	Amplifier is capable of muting
[30:23]	Rsvd3	R	0x0	Reserved
[22:16]	StepSize	R	0x05	Size of each step in the gain range = 1.5dB
[15]	Rsvd2	R	0x0	Reserved

Table 27. AFG OutAmpCap Command Response Format

Bit	Bitfield Name	RW	Reset	Description
[14:8]	NumSteps	R	0x1F	Number of steps in the gain range = 31 (32 values, -46.5dB to +0dB)
[7]	Rsvd1	R	0x0	Reserved
[6:0]	Offset	R	0x1F	0dB-step is programmed with this offset

5.4.10. AFG PwrState

Table 28. AFG PwrState Command Verb Format

	Verb ID	Payload	Response
Get	F05	00	See bitfield table
Set1	705	See bits [7:0] of bitfield table	0000_0000h

Table 29. AFG PwrState Command Response Format

Bit	Bitfield Name	RW	Reset	Description
[31:8]	Rsvd2	R	0x0	Reserved
[7:4]	Act	R	0x2	PS-Act: Actual power state of referenced node.
[3:2]	Rsvd1	R	0x0	Reserved
[1:0]	Set	RW	0x2	PS-Set: Current power setting of referenced node. 0: All Powered-On 1: D1 => PR0, PR1 2: D2 => PR0, PR1, PR2, PR6, EAPD 3: D3 => PR6, PR5, PR3, PR2, PR1, PR0, EAPD Note: PR4 is not mapped in HD Audio

5.4.11. AFG UnsolResp

Table 30. AFG UnsolResp Command Verb Format

	Verb ID	Payload	Response
Get	F08	00	See bitfield table
Set1	708	See bits [7:0] of bitfield table	0000_0000h

Table 31. AFG Unsolicited Command Response Format

Bit	Bitfield Name	RW	Reset	Description
[31:8]	Rsvd2	R	0x0	Reserved
[7]	En	RW	0x0	Allow generation of Unsolicited Responses.
[6]	Rsvd1	R	0x0	Reserved
[5:0]	Tag	RW	0x0	Software programmable field returned in top six bits (31:26) of every Unsolicited Response generated by this node.

5.4.12. AFG GPIO

Table 32. AFG GPIO Command Verb Format

	Verb ID	Payload	Response
Get	F15	00	See bitfield table
Set1	715	See bits [7:0] of bitfield table	0000_0000h

Table 33. AFG GPIO Command Response Format

Bit	Bitfield Name	RW	Reset	Description
[31:4]	Rsvd	R	0x0	Reserved
[3]	Data3	RW	0x0	Data for GPIO3 (Pin 47/EAPD). If this GPIO bit is configured as Sticky (edge-sensitive) input, it can be cleared by writing zero (one) here when the corresponding Polarity Control bit is zero (one).
[2]	Data2	RW	0x0	Data for GPIO2 (Pin 45). If this GPIO bit is configured as Sticky (edge-sensitive) input, it can be cleared by writing zero (one) here when the corresponding Polarity Control bit is zero (one).

Table 33. AFG GPIO Command Response Format

Bit	Bitfield Name	RW	Reset	Description
[1]	Data1	RW	0x0	Data for GPIO1 (Pin 34). If this GPIO bit is configured as Sticky (edge-sensitive) input, it can be cleared by writing zero (one) here when the corresponding Polarity Control bit is zero (one).
[0]	Data0	RW	0x0	Data for GPIO0 (Pin 33). If this GPIO bit is configured as Sticky (edge-sensitive) input, it can be cleared by writing zero (one) here when the corresponding Polarity Control bit is zero (one).

5.4.13. AFG GPIOEn

Table 34. AFG GPIOEn Command Verb Format

	Verb ID	Payload	Response
Get	F16	00	See bitfield table
Set1	716	See bits [7:0] of bitfield table	0000_0000h

Table 35. AFG GPIOEn Command Response Format

Bit	Bitfield Name	RW	Reset	Description
[31:4]	Rsvd	R	0x0	Reserved
[3]	Mask3	RW	0x0	Enable for GPIO3: 0 = pin is disabled (Hi-Z state); 1 = pin is enabled; behavior determined by GPIO Direction control
[2]	Mask2	RW	0x0	Enable for GPIO2: 0 = pin is disabled (Hi-Z state); 1 = pin is enabled; behavior determined by GPIO Direction control

Table 35. AFG GPIOEn Command Response Format

Bit	Bitfield Name	RW	Reset	Description
[1]	Mask1	RW	0x0	Enable for GPIO1: 0 = pin is disabled (Hi-Z state); 1 = pin is enabled; behavior determined by GPIO Direction control
[0]	Mask0	RW	0x0	Enable for GPIO0: 0 = pin is disabled (Hi-Z state); 1 = pin is enabled; behavior determined by GPIO Direction control

5.4.14. AFG GPIODir

Table 36. AFG GPIODir Command Verb Format

	Verb ID	Payload	Response
Get	F17	00	See bitfield table
Set1	717	See bits [7:0] of bitfield table	0000_0000h

Table 37. AFG GPIODir Command Response Format

Bit	Bitfield Name	RW	Reset	Description
[31:4]	Rsvd	R	0x0	Reserved
[3]	Control3	RW	0x0	Direction control for GPIO3 0 = GPIO signal is configured as input 1 = GPIO signal is configured as output
[2]	Control2	RW	0x0	Direction control for GPIO2 0 = GPIO signal is configured as input 1 = GPIO signal is configured as output
[1]	Control1	RW	0x0	Direction control for GPIO1 0 = GPIO signal is configured as input 1 = GPIO signal is configured as output
[0]	Control0	RW	0x0	Direction control for GPIO0 0 = GPIO signal is configured as input 1 = GPIO signal is configured as output

5.4.15. AFG GPIOWake

Table 38. AFG GPIOWake Command Verb Format

	Verb ID	Payload	Response
Get	F18	00	See bitfield table
Set1	718	See bits [7:0] of bitfield table	0000_0000h

Table 39. AFG GPIOWake Command Response Format

Bit	Bitfield Name	RW	Reset	Description
[31:4]	Rsvd	R	0x0	Reserved
[3]	En3	RW	0x0	Wake enable for GPIO3: 0 = wake-up event is disabled; 1 = when HD Audio link is powered down (RST# is asserted), a wake-up event will trigger a Status Change Request event on the link.
[2]	En2	RW	0x0	Wake enable for GPIO2: 0 = wake-up event is disabled; 1 = when HD Audio link is powered down (RST# is asserted), a wake-up event will trigger a Status Change Request event on the link.
[1]	En1	RW	0x0	Wake enable for GPIO1: 0 = wake-up event is disabled; 1 = when HD Audio link is powered down (RST# is asserted), a wake-up event will trigger a Status Change Request event on the link.
[0]	En0	RW	0x0	Wake enable for GPIO0: 0 = wake-up event is disabled; 1 = when HD Audio link is powered down (RST# is asserted), a wake-up event will trigger a Status Change Request event on the link.

5.4.16. AFG GPIOUnsolEn

Table 40. AFG GPIOUnsolEn Command Verb Format

	Verb ID	Payload	Response
Get	F19	00	See bitfield table
Set1	719	See bits [7:0] of bitfield table	0000_0000h

Table 41. AFG GPIOUnsolEn Command Response Format

Bit	Bitfield Name	RW	Reset	Description
[31:4]	Rsvd	R	0x0	Reserved
[3]	Mask3	RW	0x0	Unsolicited enable mask for GPIO3. If set, and the Unsolicited Response control for this widget has been enabled, an unsolicited response will be sent when GPIO3 is configured as input and changes state.
[2]	Mask2	RW	0x0	Unsolicited enable mask for GPIO2. If set, and the Unsolicited Response control for this widget has been enabled, an unsolicited response will be sent when GPIO2 is configured as input and changes state.
[1]	Mask1	RW	0x0	Unsolicited enable mask for GPIO1. If set, and the Unsolicited Response control for this widget has been enabled, an unsolicited response will be sent when GPIO1 is configured as input and changes state.
[0]	Mask0	RW	0x0	Unsolicited enable mask for GPIO0. If set, and the Unsolicited Response control for this widget has been enabled, an unsolicited response will be sent when GPIO0 is configured as input and changes state.

5.4.17. AFG GPIOSticky

Table 42. AFG GPIOSticky Command Verb Format

	Verb ID	Payload	Response
Get	F1A	00	See bitfield table
Set1	71A	See bits [7:0] of bitfield table	0000_0000h

Table 43. AFG GPIOSticky Command Response Format

Bit	Bitfield Name	RW	Reset	Description
[31:4]	Rsvd	R	0x0	Reserved
[3]	Mask3	RW	0x0	GPIO3 input type (when configured as input): 0 = Non-Sticky (level-sensitive) 1 = Sticky (edge-sensitive) Sticky inputs are cleared by writing zero to corresponding bit of GPIO Data register. GPIOPolarity determines rising or falling edge sensitivity.
[2]	Mask2	RW	0x0	GPIO2 input type (when configured as input): 0 = Non-Sticky (level-sensitive) 1 = Sticky (edge-sensitive) Sticky inputs are cleared by writing zero to corresponding bit of GPIO Data register. GPIOPolarity determines rising or falling edge sensitivity.
[1]	Mask1	RW	0x0	GPIO1 input type (when configured as input): 0 = Non-Sticky (level-sensitive) 1 = Sticky (edge-sensitive) Sticky inputs are cleared by writing zero to corresponding bit of GPIO Data register. GPIOPolarity determines rising or falling edge sensitivity.
[0]	Mask0	RW	0x0	GPIO0 input type (when configured as input): 0 = Non-Sticky (level-sensitive) 1 = Sticky (edge-sensitive) Sticky inputs are cleared by writing zero to corresponding bit of GPIO Data register. GPIOPolarity determines rising or falling edge sensitivity.

5.4.18. AFG SysID

Table 44. AFG SysID Command Verb Format

	Verb ID	Payload	Response
Get	F20	00	See bitfield table
Set1	720	See bits [7:0] of bitfield table	0000_0000h
Set2	721	See bits [15:8] of bitfield table	0000_0000h
Set3	722	See bits [23:16] of bitfield table	0000_0000h
Set4	723	See bits [31:24] of bitfield table	0000_0000h

Table 45. AFG SysID Command Response Format

Bit	Bitfield Name	RW	Reset	Description
[31:24]	Subsystem3	RW	0x00	Subsystem ID. (Any non-zero value)
[23:16]	Subsystem2	RW	0x00	Subsystem ID. (Any non-zero value)
[15:8]	Subsystem1	RW	0x01	Subsystem ID. (Any non-zero value)
[7:0]	Assembly	RW	0x00	Assembly ID. (Not applicable to CODEC vendors)

5.4.19. AFG DigMic

Table 46. AFG DigMic Command Verb Format

	Verb ID	Payload	Response
Get	FEA	00	See bitfield table
Set1	7EA	See bits [7:0] of bitfield table	0000_0000h

Table 47. AFG DigMic Command Response Format

Bit	Bitfield Name	RW	Reset	Description
[31:8]	Rsvd	R	0x0	Reserved
[7:6]	PhAdj	RW	0x0	Selects what phase of the DigMic clock the data should be latched: 0 = rising edge 1 = center of high 2 = falling edge 3 = center of low
[5:4]	Rate	RW	0x2	Selects the DigMic rate: 0 = 4 MHz 1 = 3 MHz 2 = 2 MHz 3 = 1 MHz

Table 47. AFG DigMic Command Response Format

Bit	Bitfield Name	RW	Reset	Description
[3:2]	Rsvd2	R	0x0	Reserved
[1:0]	Mode	RW	0x1	Selects the DigMic mode: 0 = disabled 1 = dual mono 2 = single stereo 0 3 = single stereo 1

5.5. DAC0Cnvtr Node (NID = 0x02)

5.5.1. DAC0Cnvtr Frmt

Table 48. DAC0Cnvtr Frmt Command Verb Format

	Verb ID	Payload	Response
Get	A	0000	See bitfield table
Set1	2	See bits [15:0] of bitfield table	0000_0000h

Table 49. DAC0Cnvtr Frmt Command Response Format

Bit	Bitfield Name	RW	Reset	Description
[31:16]	Rsvd2	R	0x0	Reserved
[15]	StrmType	R	0x0	Stream Type: only PCM streams are supported by this widget.
[14]	RateBase	RW	0x0	Sample Base Rate 0 = 48 KHz 1 = 44.1 KHz
[13:11]	RateMult	RW	0x0	Sample Base Rate Multiple 000 = 48 KHz / 44.1 KHz or less 001 = x2 010 = Reserved (x3) 011 = x4 100-111 = Reserved

Table 49. DAC0Cnvtr Frmt Command Response Format

Bit	Bitfield Name	RW	Reset	Description
[10:8]	RateDiv	RW	0x0	Sample Base Rate Divisor 000 = Divide by 1 001 = Divide by 2 010 = Divide by 3 011 = Divide by 4 100 = Divide by 5 101 = Divide by 6 110 = Divide by 7 111 = Divide by 8
[7]	Rsvd1	R	0x0	Reserved
[6:4]	NumBits	RW	0x3	Bits per Sample: 000 = 8 bits 001 = 16 bits 010 = 20 bits 011 = 24 bits 100-111 = Reserved
[3:0]	NumChan	RW	0x1	Number of Channels in each frame of the stream. 0000 = 1 channel 0001 = 2 channels ... 1111 = 16 channels

5.5.2. DAC0Cnvtr WCap

Table 50. DAC0Cnvtr WCap Command Verb Format

	Verb ID	Payload	Response
Get	F00	09	See bitfield table

Table 51. DAC0Cnvtr WCap Command Response Format

Bit	Bitfield Name	RW	Reset	Description
[31:24]	Rsvd2	R	0x0	Reserved
[23:20]	Type	R	0x0	Widget type = Audio Output
[19:16]	Delay	R	0xD	Number of sample delays through widget
[15:12]	Rsvd1	R	0x0	Reserved

Table 51. DAC0Cnvtr WCap Command Response Format

Bit	Bitfield Name	RW	Reset	Description
[11]	SwapCap	R	0x0	No left/right channel swap capability
[10]	PwrCntrl	R	0x1	Power State control is supported
[9]	DigitalStrm	R	0x0	Widget supports an Analog stream
[8]	ConnList	R	0x0	No connection list is present
[7]	UnsolCap	R	0x0	No support for Unsolicited Response
[6]	ProcWidget	R	0x0	No Processing Controls parameter
[5]	Stripe	R	0x0	No support for striping
[4]	FormatOvrd	R	0x0	No format info; use default format parameters from Audio Function node instead
[3]	AmpParamOvrd	R	0x0	No amplifier info; use default amplifier parameters from Audio Function node instead
[2]	OutAmpPrsnt	R	0x0	No output amp
[1]	InAmpPrsnt	R	0x0	No input amp
[0]	Stereo	R	0x1	Stereo widget

5.5.3. DAC0Cnvtr PwrState

Table 52. DAC0Cnvtr PwrState Command Verb Format

	Verb ID	Payload	Response
Get	F05	00	See bitfield table
Set1	705	See bits [7:0] of bitfield table	0000_0000h

Table 53. DAC0Cnvtr PwrState Command Response Format

Bit	Bitfield Name	RW	Reset	Description
[31:8]	Rsvd2	R	0x0	Reserved
[7:4]	Act	R	0x3	PS-Act: Actual power state of referenced node.

Table 53. DAC0Cnvtr PwrState Command Response Format

Bit	Bitfield Name	RW	Reset	Description
[3:2]	Rsvd1	R	0x0	Reserved
[1:0]	Set	RW	0x3	PS-Set: Current power setting of referenced node. 00 - Fully on. 01 - Fully on. 10 - Fully on. 11 - Powered down.

5.5.4. DAC0Cnvtr Stream

Table 54. DAC0Cnvtr Stream Command Verb Format

	Verb ID	Payload	Response
Get	F06	00	See bitfield table
Set1	706	See bits [7:0] of bitfield table	0000_0000h

Table 55. DAC0Cnvtr Stream Command Response Format

Bit	Bitfield Name	RW	Reset	Description
[31:8]	Rsvd	R	0x0	Reserved
[7:4]	ID	RW	0x0	Software-programmable integer representing link stream ID used by the converter widget. By convention stream 0 is reserved as unused.
[3:0]	Ch	RW	0x0	Integer representing lowest channel used by converter.

5.6. ADC0Cnvtr Node (NID = 0x03)

5.6.1. ADC0Cnvtr Frmt

Table 56. ADC0Cnvtr Frmt Command Verb Format

	Verb ID	Payload	Response
Get	A	0000	See bitfield table
Set1	2	See bits [15:0] of bitfield table	0000_0000h

Table 57. ADC0Cnvtr Frmt Command Response Format

Bit	Bitfield Name	RW	Reset	Description
[31:16]	Rsvd2	R	0x0	Reserved
[15]	StrmType	RW	0x0	Stream Type 0 = PCM 1 = Non-PCM (remaining bits in this verb have other meanings)
[14]	RateBase	RW	0x0	Sample Base Rate 0 = 48 KHz 1 = 44.1 KHz
[13:11]	RateMult	RW	0x0	Sample Base Rate Multiple 000 = 48 KHz / 44.1 KHz or less 001 = x2 010 = Reserved (x3) 011 = x4 100-111 = Reserved
[10:8]	RateDiv	RW	0x0	Sample Base Rate Divisor 000 = Divide by 1 001 = Divide by 2 010 = Divide by 3 011 = Divide by 4 100 = Divide by 5 101 = Divide by 6 110 = Divide by 7 111 = Divide by 8
[7]	Rsvd1	R	0x0	Reserved

Table 57. ADC0Cnvtr Frmt Command Response Format

Bit	Bitfield Name	RW	Reset	Description
[6:4]	NumBits	RW	0x3	Bits per Sample 000 = 8 bits 001 = 16 bits 010 = 20 bits 011 = 24 bits 100-111 = Reserved
[3:0]	NumChan	RW	0x1	Number of Channels in each frame of the stream. 0000 = 1 channel 0001 = 2 channels ... 1111 = 16 channels

5.6.2. ADC0Cnvtr WCap

Table 58. ADC0Cnvtr WCap Command Verb Format

	Verb ID	Payload	Response
Get	F00	09	See bitfield table

Table 59. ADC0Cnvtr WCap Command Response Format

Bit	Bitfield Name	RW	Reset	Description
[31:24]	Rsvd2	R	0x0	Reserved
[23:20]	Type	R	0x1	Widget type = Audio Input
[19:16]	Delay	R	0xD	Number of sample delays through widget
[15:12]	Rsvd1	R	0x0	Reserved
[11]	SwapCap	R	0x0	No left/right channel swap capability
[10]	PwrCntrl	R	0x1	Power State control is supported
[9]	DigitalStrm	R	0x0	Widget supports an Analog stream
[8]	ConnList	R	0x1	Connection list is present
[7]	UnsolCap	R	0x0	No support for Unsolicited Response

Table 59. ADC0Cnvtr WCap Command Response Format

Bit	Bitfield Name	RW	Reset	Description
[6]	ProcWidget	R	0x1	Software should query the Processing Controls parameter for this widget.
[5]	Stripe	R	0x0	No support for striping
[4]	FormatOvrd	R	0x0	No format info; use default format parameters from Audio Function node instead
[3]	AmpParamOvrd	R	0x0	No amplifier info; use default amplifier parameters from Audio Function node instead
[2]	OutAmpPrsnt	R	0x0	No output amp
[1]	InAmpPrsnt	R	0x0	No input amp
[0]	Stereo	R	0x1	Stereo widget

5.6.3. ADC0Cnvtr ConnLen

Table 60. ADC0Cnvtr ConnLen Command Verb Format

	Verb ID	Payload	Response
Get	F00	0E	See bitfield table

Table 61. ADC0Cnvtr ConnLen Command Response Format

Bit	Bitfield Name	RW	Reset	Description
[31:8]	Rsvd	R	0x0	Reserved.
[7]	LongForm	R	0x0	Connection list uses short-form (7-bit) NID entries.
[6:0]	N	R	0x01	Number of NID entries in connection list.

5.6.4. *ADC0Cnvtr ConnLst*

Table 62. ADC0Cnvtr ConnLst Command Verb Format

	Verb ID	Payload	Response
Get	F02	00	See bitfield table

Table 63. ADC0Cnvtr ConnLst Command Response Format

Bit	Bitfield Name	RW	Reset	Description
[31:24]	Entry3	R	0x00	Unused list entry.
[23:16]	Entry2	R	0x00	Unused list entry.
[15:8]	Entry1	R	0x00	Unused list entry.
[7:0]	Entry0	R	0x14	ADC0InMux

5.6.5. *ADC0Cnvtr ProcState*

Table 64. ADC0Cnvtr ProcState Command Verb Format

	Verb ID	Payload	Response
Get	F03	00	See bitfield table
Set1	703	See bits [7:0] of bitfield table	0000_0000h

Table 65. ADC0Cnvtr ProcState Command Response Format

Bit	Bitfield Name	RW	Reset	Description
[31:8]	Rsvd2	R	0x0	Reserved
[7]	HPFOffsetDis	RW	0x0	High Pass Filter Offset Calculation Disable 0 = Calculation enabled. 1 = Calculation disabled.
[6:2]	Rsvd1	R	0x0	Reserved
[1:0]	HPFByp	RW	0x1	Processing State = 00 (OFF): bypass the ADC high pass filter; Processing State = 01, 10, 11 (ON or BENIGN): ADC high pass filter is enabled.

5.6.6. *ADC0Cnvtr PwrState*

Table 66. ADC0Cnvtr PwrState Command Verb Format

	Verb ID	Payload	Response
Get	F05	00	See bitfield table
Set1	705	See bits [7:0] of bitfield table	0000_0000h

Table 67. ADC0Cnvtr PwrState Command Response Format

Bit	Bitfield Name	RW	Reset	Description
[31:8]	Rsvd2	R	0x0	Reserved
[7:4]	Act	R	0x3	PS-Act: Actual power state of referenced node.
[3:2]	Rsvd1	R	0x0	Reserved
[1:0]	Set	RW	0x3	PS-Set: Current power setting of referenced node. 00 - Fully on. 01 - Fully on. 10 - Fully on. 11 - Powered down (default powered down)

5.6.7. *ADC0Cnvtr Stream*

Table 68. ADC0Cnvtr Stream Command Verb Format

	Verb ID	Payload	Response
Get	F06	00	See bitfield table
Set1	706	See bits [7:0] of bitfield table	0000_0000h

Table 69. ADC0Cnvtr Stream Command Response Format

Bit	Bitfield Name	RW	Reset	Description
[31:8]	Rsvd	R	0x0	Reserved

Table 69. ADC0Cnvtr Stream Command Response Format

Bit	Bitfield Name	RW	Reset	Description
[7:4]	ID	RW	0x0	Software-programmable integer representing link stream ID used by the converter widget. By convention stream 0 is reserved as unused.
[3:0]	Ch	RW	0x0	Integer representing lowest channel used by converter

5.7. SPDIFinCnvtr Node (NID = 0x04)

5.7.1. SPDIFinCnvtr Frmt

Table 70. SPDIFinCnvtr Frmt Command Verb Format

	Verb ID	Payload	Response
Get	A	0000	See bitfield table
Set1	2	See bits [15:0] of bitfield table	0000_0000h

Table 71. SPDIFinCnvtr Frmt Command Response Format

Bit	Bitfield Name	RW	Reset	Description
[31:16]	Rsvd2	R	0x0	Reserved
[15]	StrmType	RW	0x0	N/A. (Stream Type 0 = PCM 1 = Non-PCM)
[14]	RateBase	RW	0x0	Sample Base Rate 0 = 48 KHz 1 = 44.1 KHz
[13:11]	RateMult	RW	0x0	Sample Base Rate Multiple 000 = 48 KHz / 44.1 KHz or less 001 = x2 010 = Reserved (x3) 011 = x4 100-111 = Reserved

Table 71. SPDIFinCnvtr Frmt Command Response Format

Bit	Bitfield Name	RW	Reset	Description
[10:8]	RateDiv	RW	0x0	Sample Base Rate Divisor 000 = Divide by 1 001 = Divide by 2 010 = Divide by 3 011 = Divide by 4 100 = Divide by 5 101 = Divide by 6 110 = Divide by 7 111 = Divide by 8
[7]	Rsvd1	R	0x0	Reserved
[6:4]	NumBits	RW	0x3	Bits per Sample 000 = 8 bits 001 = 16 bits 010 = 20 bits 011 = 24 bits 100-111 = Reserved
[3:0]	NumChan	RW	0x1	Number of Channels in each frame of the stream. 0000 = 1 channel 0001 = 2 channels ... 1111 = 16 channels

5.7.2. SPDIFinCnvtr WCap

Table 72. SPDIFinCnvtr WCap Command Verb Format

	Verb ID	Payload	Response
Get	F00	09	See bitfield table

Table 73. SPDIFinCnvtr WCap Command Response Format

Bit	Bitfield Name	RW	Reset	Description
[31:24]	Rsvd2	R	0x0	Reserved
[23:20]	Type	R	0x1	Widget type = Audio Input
[19:16]	Delay	R	0x4	Number of sample delays through widget
[15:12]	Rsvd1	R	0x0	Reserved

Table 73. SPDIFinCnvtr WCap Command Response Format

Bit	Bitfield Name	RW	Reset	Description
[11]	SwapCap	R	0x0	No left/right channel swap capability
[10]	PwrCntrl	R	0x0	No support for Power State control
[9]	DigitalStrm	R	0x1	Widget supports a Digital stream
[8]	ConnList	R	0x1	Connection list is present
[7]	UnsolCap	R	0x0	No support for Unsolicited Response
[6]	ProcWidget	R	0x0	No Processing Controls parameter
[5]	Stripe	R	0x0	No support for striping
[4]	FormatOvrd	R	0x1	Widget contains format info; software should query
[3]	AmpParamOvrd	R	0x0	No amplifier info; use default amplifier parameters from Audio Function node instead
[2]	OutAmpPrsnt	R	0x0	No output amp
[1]	InAmpPrsnt	R	0x0	No input amp
[0]	Stereo	R	0x1	Stereo widget

5.7.3. SPDIFinCnvtr FrmtCap

Table 74. SPDIFinCnvtr FrmtCap Command Verb Format

	Verb ID	Payload	Response
Get	F00	0A	See bitfield table

Table 75. SPDIFinCnvtr FrmtCap Command Response Format

Bit	Bitfield Name	RW	Reset	Description
[31:21]	Rsvd2	R	0x0	Reserved
[20]	B32	R	0x0	32 bit audio formats are NOT supported
[19]	B24	R	0x1	24 bit audio formats are supported

Table 75. SPDIFinCnvtr FrmtCap Command Response Format

Bit	Bitfield Name	RW	Reset	Description
[18]	B20	R	0x1	20 bit audio formats are supported
[17]	B16	R	0x1	16 bit audio formats are supported
[16]	B8	R	0x0	8 bit audio formats are NOT supported
[15:12]	Rsvd1	R	0x0	Reserved
[11]	R12	R	0x0	384 KHz rate (8/1*48 KHz) NOT supported
[10]	R11	R	0x0	192.0 KHz rate (4/1*48 KHz) NOT supported
[9]	R10	R	0x0	176.4 KHz rate (4/1*44.1 KHz) NOT supported
[8]	R9	R	0x1	96.0 KHz rate (2/1*48 KHz) supported
[7]	R8	R	0x0	88.2 KHz rate (2/1*44.1 KHz) NOT supported
[6]	R7	R	0x1	48.0 KHz rate supported (REQUIRED)
[5]	R6	R	0x1	44.1 KHz rate supported
[4]	R5	R	0x0	32.0 KHz rate (2/3*48 KHz) NOT supported
[3]	R4	R	0x0	22.05 KHz rate (1/2*44.1 KHz) NOT supported
[2]	R3	R	0x0	16.0 KHz rate (1/3*48 KHz) NOT supported
[1]	R2	R	0x0	11.025 KHz rate (1/4*44.0 KHz) NOT supported
[0]	R1	R	0x0	8.0 KHz rate (1/6*48 KHz) NOT supported

5.7.4. SPDIFinCnvtr StreamCap

Table 76. SPDIFinCnvtr StreamCap Command Verb Format

	Verb ID	Payload	Response
Get	F00	0B	See bitfield table

Table 77. SPDIFinCnvtr StreamCap Command Response Format

Bit	Bitfield Name	RW	Reset	Description
[31:3]	Rsvd	R	0x0	Reserved
[2]	NonPCM	R	0x1	Non-PCM data supported.
[1]	Float32	R	0x0	No support for Float32 data.
[0]	PCM	R	0x1	PCM-formatted data supported.

5.7.5. SPDIFinCnvtr ConnLen

Table 78. SPDIFinCnvtr ConnLen Command Verb Format

	Verb ID	Payload	Response
Get	F00	0E	See bitfield table

Table 79. SPDIFinCnvtr ConnLen Command Response Format

Bit	Bitfield Name	RW	Reset	Description
[31:8]	Rsvd	R	0x0	Reserved.
[7]	LongForm	R	0x0	Connection list uses short-form (7-bit) NID entries.
[6:0]	N	R	0x01	Number of NID entries in connection list.

5.7.6. SPDIFinCnvtr ConnLst

Table 80. SPDIFinCnvtr ConnLst Command Verb Format

	Verb ID	Payload	Response
Get	F02	00	See bitfield table

Table 81. SPDIFinCnvtr ConnLst Command Response Format

Bit	Bitfield Name	RW	Reset	Description
[31:24]	Entry3	R	0x00	Unused list entry.
[23:16]	Entry2	R	0x00	Unused list entry.
[15:8]	Entry1	R	0x00	Unused list entry.
[7:0]	Entry0	R	0x07	DigIn Pin widget

5.7.7. SPDIFinCnvtr Stream

Table 82. SPDIFinCnvtr Stream Command Verb Format

	Verb ID	Payload	Response
Get	F06	00	See bitfield table
Set1	706	See bits [7:0] of bitfield table	0000_0000h

Table 83. SPDIFinCnvtr Stream Command Response Format

Bit	Bitfield Name	RW	Reset	Description
[31:8]	Rsvd	R	0x0	Reserved
[7:4]	ID	RW	0x0	Software-programmable integer representing link stream ID used by the converter widget. By convention stream 0 is reserved as unused.
[3:0]	Ch	RW	0x0	Integer representing lowest channel used by converter

5.7.8. SPDIFinCnvtr DigCtl

Table 84. SPDIFinCnvtr DigCtl Command Verb Format

	Verb ID	Payload	Response
Get	F0D	00	See bitfield table

Table 84. SPDIFinCnvtr DigCtl Command Verb Format

	Verb ID	Payload	Response
Set1	70D	See bits [7:0] of bitfield table	0000_0000h
Set2	70E	See bits [15:8] of bitfield table	0000_0000h

Table 85. SPDIFinCnvtr DigCtl Command Response Format

Bit	Bitfield Name	RW	Reset	Description
[31:15]	Rsvd2	R	0x0	Reserved
[14:8]	CC	R	0x00	CC[6:0] - Category Code
[7]	L	R	0x0	L - Generation Level
[6]	PRO	R	0x0	PRO - Professional
[5]	AUDIO	R	0x0	/AUDIO - Non-Audio
[4]	COPY	R	0x0	COPY - Copyright
[3]	PRE	R	0x0	PRE - Preemphasis
[2]	Rsvd1	R	0x0	Reserved (VCFG bit applies only to output streams)
[1]	V	R	0x0	V - Validity
[0]	DigEn	RW	0x0	DigEn - Digital Enable

5.8. SPDIFoutCnvtr Node (NID = 0x05)

5.8.1. SPDIFoutCnvtr Frmt

Table 86. SPDIFoutCnvtr Frmt Command Verb Format

	Verb ID	Payload	Response
Get	A	0000	See bitfield table
Set1	2	See bits [15:0] of bitfield table	0000_0000h

Table 87. SPDIFoutCnvtr Frmt Command Response Format

Bit	Bitfield Name	RW	Reset	Description
[31:16]	Rsvd2	R	0x0	Reserved
[15]	StrmType	RW	0x0	Stream Type 0 = PCM 1 = Non-PCM (remaining bits in this verb have other meanings)
[14]	RateBase	RW	0x0	Sample Base Rate 0 = 48 KHz 1 = 44.1 KHz
[13:11]	RateMult	RW	0x0	Sample Base Rate Multiple: 000 = 48 KHz / 44.1 KHz or less; 001 = x2; 010 = Reserved (x3); 011 = x4; 100-111 = Reserved
[10:8]	RateDiv	RW	0x0	Sample Base Rate Divisor 000 = Divide by 1 001 = Divide by 2 010 = Divide by 3 011 = Divide by 4 100 = Divide by 5 101 = Divide by 6 110 = Divide by 7 111 = Divide by 8
[7]	Rsvd1	R	0x0	Reserved
[6:4]	NumBits	RW	0x3	Bits per Sample 000 = 8 bits 001 = 16 bits 010 = 20 bits 011 = 24 bits 100-111 = Reserved
[3:0]	NumChan	RW	0x1	Number of Channels in each frame of the stream. 0000 = 1 channel 0001 = 2 channels ... 1111 = 16 channels

5.8.2. SPDIFoutCnvtr WCap

Table 88. SPDIFoutCnvtr WCap Command Verb Format

	Verb ID	Payload	Response
Get	F00	09	See bitfield table

Table 89. SPDIFoutCnvtr WCap Command Response Format

Bit	Bitfield Name	RW	Reset	Description
[31:24]	Rsvd2	R	0x0	Reserved
[23:20]	Type	R	0x0	Widget type = Audio Output
[19:16]	Delay	R	0x4	Number of sample delays through widget
[15:12]	Rsvd1	R	0x0	Reserved
[11]	SwapCap	R	0x0	No left/right channel swap capability
[10]	PwrCntrl	R	0x0	No support for Power State control
[9]	DigitalStrm	R	0x1	Widget supports a Digital stream
[8]	ConnList	R	0x0	No connection list is present
[7]	UnsolCap	R	0x0	No support for Unsolicited Response
[6]	ProcWidget	R	0x0	No Processing Controls parameter
[5]	Stripe	R	0x0	No support for striping
[4]	FormatOvrd	R	0x1	Widget contains format info; software should query
[3]	AmpParamOvrd	R	0x0	No amplifier info; use default amplifier parameters from Audio Function node instead
[2]	OutAmpPrsnt	R	0x0	No output amp
[1]	InAmpPrsnt	R	0x0	No input amp
[0]	Stereo	R	0x1	Stereo widget

5.8.3. SPDIFoutCnvtr FrmtCap

Table 90. SPDIFoutCnvtr FrmtCap Command Verb Format

	Verb ID	Payload	Response
Get	F00	0A	See bitfield table

Table 91. SPDIFoutCnvtr FrmtCap Command Response Format

Bit	Bitfield Name	RW	Reset	Description
[31:21]	Rsvd2	R	0x0	Reserved
[20]	B32	R	0x0	32 bit audio formats are NOT supported
[19]	B24	R	0x1	24 bit audio formats are supported
[18]	B20	R	0x1	20 bit audio formats are supported
[17]	B16	R	0x1	16 bit audio formats are supported
[16]	B8	R	0x0	8 bit audio formats are NOT supported
[15:12]	Rsvd1	R	0x0	Reserved
[11]	R12	R	0x0	384 KHz rate (8/1*48 KHz) NOT supported
[10]	R11	R	0x0	192.0 KHz rate (4/1*48 KHz) NOT supported
[9]	R10	R	0x0	176.4 KHz rate (4/1*44.1 KHz) NOT supported
[8]	R9	R	0x1	96.0 KHz rate (2/1*48 KHz) supported
[7]	R8	R	0x1	88.2 KHz rate (2/1*44.1 KHz) supported
[6]	R7	R	0x1	48.0 KHz rate supported (REQUIRED)
[5]	R6	R	0x1	44.1 KHz rate supported
[4]	R5	R	0x0	32.0 KHz rate (2/3*48 KHz) NOT supported
[3]	R4	R	0x0	22.05 KHz rate (1/2*44.1 KHz) NOT supported
[2]	R3	R	0x0	16.0 KHz rate (1/3*48 KHz) NOT supported
[1]	R2	R	0x0	11.025 KHz rate (1/4*44.0 KHz) NOT supported
[0]	R1	R	0x0	8.0 KHz rate (1/6*48 KHz) NOT supported

5.8.4. SPDIFoutCnvtr StreamCap

Table 92. SPDIFoutCnvtr StreamCap Command Verb Format

	Verb ID	Payload	Response
Get	F00	0B	See bitfield table

Table 93. SPDIFoutCnvtr StreamCap Command Response Format

Bit	Bitfield Name	RW	Reset	Description
[31:3]	Rsvd	R	0x0	Reserved
[2]	NonPCM	R	0x1	Non-PCM data supported.
[1]	Float32	R	0x0	No support for Float32 data.
[0]	PCM	R	0x1	PCM-formatted data supported.

5.8.5. SPDIFoutCnvtr Stream

Table 94. SPDIFoutCnvtr Stream Command Verb Format

	Verb ID	Payload	Response
Get	F06	00	See bitfield table
Set1	706	See bits [7:0] of bitfield table	0000_0000h

Table 95. SPDIFoutCnvtr Stream Command Response Format

Bit	Bitfield Name	RW	Reset	Description
[31:8]	Rsvd	R	0x0	Reserved
[7:4]	ID	RW	0x0	Software-programmable integer representing link stream ID used by the converter widget. By convention stream 0 is reserved as unused.
[3:0]	Ch	RW	0x0	Integer representing lowest channel used by converter

5.8.6. SPDIFoutCnvtr DigCtl

Table 96. SPDIFoutCnvtr DigCtl Command Verb Format

	Verb ID	Payload	Response
Get	F0D	00	See bitfield table
Set1	70D	See bits [7:0] of bitfield table	0000_0000h
Set2	70E	See bits [15:8] of bitfield table	0000_0000h

Table 97. SPDIFoutCnvtr DigCtl Command Response Format

Bit	Bitfield Name	RW	Reset	Description
[31:16]	Rsvd2	R	0x0	Reserved
[15]	Rsvd1	R	0x0	Rsvd
[14:8]	CC	RW	0x00	CC[6:0] - Category Code
[7]	L	RW	0x0	L - Generation Level
[6]	PRO	RW	0x0	PRO - Professional
[5]	AUDIO	RW	0x0	/AUDIO - Non-Audio
[4]	COPY	RW	0x0	COPY - Copyright
[3]	PRE	RW	0x0	PRE - Preemphasis
[2]	VCFG	RW	0x0	VCFG - Validity Config
[1]	V	RW	0x0	V - Validity
[0]	DigEn	RW	0x0	DigEn - Digital Enable

5.9. DAC0Mux Node (NID = 0x06)

5.9.1. DAC0Mux WCap

Table 98. DAC0Mux WCap Command Verb Format

	Verb ID	Payload	Response
Get	F00	09	See bitfield table

Table 99. DAC0Mux WCap Command Response Format

Bit	Bitfield Name	RW	Reset	Description
[31:24]	Rsvd2	R	0x0	Reserved
[23:20]	Type	R	0x3	Widget type = Audio Selector
[19:16]	Delay	R	0x0	Number of sample delays through widget
[15:12]	Rsvd1	R	0x0	Reserved
[11]	SwapCap	R	0x1	Left and right channels can be swapped
[10]	PwrCntrl	R	0x0	No support for Power State control
[9]	DigitalStrm	R	0x0	Widget supports an Analog stream
[8]	ConnList	R	0x1	Connection list is present
[7]	UnsolCap	R	0x0	No support for Unsolicited Response
[6]	ProcWidget	R	0x0	No Processing Controls parameter.
[5]	Stripe	R	0x0	No support for striping
[4]	FormatOvrd	R	0x0	No format info; use default format parameters from Audio Function node instead
[3]	AmpParamOvrd	R	0x0	No amplifier info; use default amplifier parameters from Audio Function node instead
[2]	OutAmpPrsnt	R	0x0	No output amp
[1]	InAmpPrsnt	R	0x0	No input amp
[0]	Stereo	R	0x1	Stereo widget

5.9.2. DAC0Mux ConnLen

Table 100. DAC0Mux ConnLen Command Verb Format

	Verb ID	Payload	Response
Get	F00	0E	See bitfield table

Table 101. DAC0Mux ConnLen Command Response Format

Bit	Bitfield Name	RW	Reset	Description
[31:8]	Rsvd	R	0x0	Reserved.
[7]	LongForm	R	0x0	Connection list uses short-form (7-bit) NID entries.
[6:0]	N	R	0x03	Number of NID entries in connection list.

5.9.3. DAC0Mux ConnSel

Table 102. DAC0Mux ConnSel Command Verb Format

	Verb ID	Payload	Response
Get	F01	00	See bitfield table
Set1	701	See bits [7:0] of bitfield table	0000_0000h

Table 103. DAC0Mux ConnSel Command Response Format

Bit	Bitfield Name	RW	Reset	Description
[31:2]	Rsvd	R	0x0	Reserved
[1:0]	Index	RW	0x0	Connection select control index.

5.9.4. DAC0Mux ConnLst

Table 104. DAC0Mux ConnLst Command Verb Format

	Verb ID	Payload	Response
Get	F02	00	See bitfield table

Table 105. DAC0Mux ConnLst Command Response Format

Bit	Bitfield Name	RW	Reset	Description
[31:24]	Entry3	R	0x00	Unused list entry.
[23:16]	Entry2	R	0x14	ADC0InMux widget.

Table 105. DAC0Mux ConnLst Command Response Format

Bit	Bitfield Name	RW	Reset	Description
[15:8]	Entry1	R	0x07	DigIn Pin widget.
[7:0]	Entry0	R	0x02	DAC Analog converter widget.

5.9.5. DAC0Mux LR

Table 106. DAC0Mux LR Command Verb Format

	Verb ID	Payload	Response
Get	F0C	00	See bitfield table
Set1	70C	See bits [7:0] of bitfield table	0000_0000h

Table 107. DAC0Mux LR Command Response Format

Bit	Bitfield Name	RW	Reset	Description
[31:3]	Rsvd2	R	0x0	Reserved
[2]	SwapEn	RW	0x0	1 = swap left and right channels of this Widget.
[1:0]	Rsvd1	R	0x0	Reserved

5.10. DigInPin Node (NID = 0x07)

5.10.1. DigInPin WCap

Table 108. DigInPin WCap Command Verb Format

	Verb ID	Payload	Response
Get	F00	09	See bitfield table

Table 109. DigInPin WCap Command Response Format

Bit	Bitfield Name	RW	Reset	Description
[31:24]	Rsvd2	R	0x0	Reserved
[23:20]	Type	R	0x4	Widget type = Pin Complex
[19:16]	Delay	R	0x3	Number of sample delays through widget
[15:12]	Rsvd1	R	0x0	Reserved
[11]	SwapCap	R	0x0	No left/right channel swap capability
[10]	PwrCntrl	R	0x1	Power State control is supported
[9]	DigitalStrm	R	0x1	Widget supports a Digital stream
[8]	ConnList	R	0x0	No connection list is present
[7]	UnsolCap	R	0x1	Unsolicited Response is supported
[6]	ProcWidget	R	0x0	No Processing Controls parameter
[5]	Stripe	R	0x0	No support for striping
[4]	FormatOvrd	R	0x0	N/A for pin complex
[3]	AmpParamOvrd	R	0x0	No amplifier info; use default amplifier parameters from Audio Function node instead
[2]	OutAmpPrsnt	R	0x0	No output amp
[1]	InAmpPrsnt	R	0x0	No input amp
[0]	Stereo	R	0x1	Stereo widget

5.10.2. DigInPin Cap

Table 110. DigInPin Cap Command Verb Format

	Verb ID	Payload	Response
Get	F00	0C	See bitfield table

Table 111. DigInPin Cap Command Response Format

Bit	Bitfield Name	RW	Reset	Description
[31:17]	Rsvd2	R	0x0	Reserved
[16]	EapdCap	R	0x1	This widget controls EAPD pin
[15:8]	VRefCntrl	R	0x00	VRef generation not supported by this pin complex.
[7]	Rsvd1	R	0x0	Reserved
[6]	BalancedIO	R	0x0	Pin complex does not have balanced pins.
[5]	InCap	R	0x1	Pin complex is input capable.
[4]	OutCap	R	0x0	Pin complex is not output capable. (EAPD does not equal the output stream)
[3]	HPhnDrvCap	R	0x0	Pin does not have a headphone amplifier.
[2]	PresDtctCap	R	0x1	Pin complex can perform Presence Detect.
[1]	TrigRqd	R	0x0	N/A
[0]	ImpSenseCap	R	0x0	Pin complex does not support impedance sense.

5.10.3. DigInPin PwrState

Table 112. DigInPin PwrState Command Verb Format

	Verb ID	Payload	Response
Get	F05	00	See bitfield table
Set1	705	See bits [7:0] of bitfield table	0000_0000h

Table 113. DigInPin PwrState Command Response Format

Bit	Bitfield Name	RW	Reset	Description
[31:8]	Rsvd2	R	0x0	Reserved
[7:4]	Act	R	0x3	PS-Act: Actual power state of referenced node.

Table 113. DigInPin PwrState Command Response Format

Bit	Bitfield Name	RW	Reset	Description
[3:2]	Rsvd1	R	0x0	Reserved
[1:0]	Set	RW	0x3	PS-Set: Current power setting of referenced node. 00 - Fully on. 01 - Fully on. 10 - Fully on. 11 - Powered down (default powered down)

5.10.4. DigInPin Ctl

Table 114. DigInPin Ctl Command Verb Format

	Verb ID	Payload	Response
Get	F07	00	See bitfield table
Set1	707	See bits [7:0] of bitfield table	0000_0000h

Table 115. DigInPin Ctl Command Response Format

Bit	Bitfield Name	RW	Reset	Description
[31:6]	Rsvd2	R	0x0	Reserved
[5]	InEn	RW	0x0	1 = (CODEC) input path of Pin Widget is enabled
[4:0]	Rsvd1	R	0x0	Reserved

5.10.5. DigInPin UnsolResp

Table 116. DigInPin UnsolResp Command Verb Format

	Verb ID	Payload	Response
Get	F08	00	See bitfield table
Set1	708	See bits [7:0] of bitfield table	0000_0000h

Table 117. DigInPin UnsolResp Command Response Format

Bit	Bitfield Name	RW	Reset	Description
[31:8]	Rsvd2	R	0x00	Reserved
[7]	En	RW	0x0	Allow generation of Unsolicited Responses. Unsolicited response events occur upon lock or loss-of-lock by SPDIF-in clock recovery circuit.
[6]	Rsvd1	R	0x0	Reserved.
[5:0]	Tag	RW	0x00	Software programmable field returned in top six bits (31:26) of every Unsolicited Response generated by this node.

5.10.6. DigInPin Sense

Table 118. DigInPin Sense Command Verb Format

	Verb ID	Payload	Response
Get	F09	00	See bitfield table
Set1	709	See bits [7:0] of bitfield table	0000_0000h
Set2	709	See bits [7:0] of bitfield table	0000_0000h

Table 119. DigInPin Sense Command Response Format

Bit	Bitfield Name	RW	Reset	Description
[31]	Present	R	0x0	1 = something is plugged into jack associated with Pin Complex. For this widget, Presence Detect indicates that the SPDIF-in clock recovery circuit has locked onto a valid SPDIF-in sampling frequency. Any change in status will generate an Unsolicited Response, if enabled with verb 708.
[30:0]	Rsvd	R	0x0	Reserved. Impedance sense not supported for this Pin Complex.

5.10.7. DigInPin EAPD

Table 120. DigInPin EAPD Command Verb Format

	Verb ID	Payload	Response
Get	F0C	00	See bitfield table
Set1	70C	See bits [7:0] of bitfield table	0000_0000h

Table 121. DigInPin EAPD Command Response Format

Bit	Bitfield Name	RW	Reset	Description
[31:2]	Rsvd2	R	0x0	Reserved
[1]	Data	RW	0x0	EAPD value reflected on the EAPD pin. 0 = power down external amp; 1 = power up external amp if PwrState < 0x2. If PwrState > = 0x2, Pin47 is Hi-Z. An external pull-down is required if EAPD must be low when Pin Widget is powered down.
[0]	Rsvd1	R	0x0	Reserved

5.10.8. DigInPin Config

Table 122. DigInPin Config Command Verb Format

	Verb ID	Payload	Response
Get	F1C	00	See bitfield table
Set1	71C	See bits [7:0] of bitfield table	0000_0000h
Set2	71D	See bits [15:8] of bitfield table	0000_0000h
Set3	71E	See bits [23:16] of bitfield table	0000_0000h
Set4	71F	See bits [31:24] of bitfield table	0000_0000h

Table 123. DigInPin Config Command Response Format

Bit	Bitfield Name	RW	Reset	Description
[31:30]	Port	RW	0x0	External Port Connectivity of the Pin Complex. 0 = Port Complex is connected to a jack
[29:24]	Location	RW	0x01	Physical location of the jack. Optical jack at mainboard rear.
[23:20]	Device	RW	0xC	Default Device, indicating intended use of jack. C = SPDIF In
[19:16]	Connection	RW	0x5	Connection Type. 5 = optical
[15:12]	Color	RW	0xE	Color of physical jack. E = White
[11:8]	Misc	RW	0x1	Misc[0] = Jack Detect override.
[7:4]	Assoc	RW	0x5	Default Association for Pin Complex groups. Reserved value 0000b should not be used. Value 1111b indicates lowest priority.
[3:0]	Sequence	RW	0x0	All Widgets in an association must have unique sequence number.

5.11. DigOutPin Node (NID = 0x08)

5.11.1. DigOutPin WCap

Table 124. DigOutPin WCap Command Verb Format

	Verb ID	Payload	Response
Get	F00	09	See bitfield table

Table 125. DigOutPin WCap Command Response Format

Bit	Bitfield Name	RW	Reset	Description
[31:24]	Rsvd2	R	0x0	Reserved
[23:20]	Type	R	0x4	Widget type = Pin Complex

Table 125. DigOutPin WCap Command Response Format

Bit	Bitfield Name	RW	Reset	Description
[19:16]	Delay	R	0x0	Number of sample delays through widget
[15:12]	Rsvd1	R	0x0	Reserved
[11]	SwapCap	R	0x0	No left/right channel swap capability
[10]	PwrCntrl	R	0x0	No support for Power State control
[9]	DigitalStrm	R	0x1	Widget supports a Digital stream
[8]	ConnList	R	0x1	Connection list is present
[7]	UnsolCap	R	0x0	No support for Unsolicited Response
[6]	ProcWidget	R	0x0	No Processing Controls parameter
[5]	Stripe	R	0x0	No support for striping
[4]	FormatOvrđ	R	0x0	N/A for pin complex
[3]	AmpParamOvrđ	R	0x0	No amplifier info; use default amplifier parameters from Audio Function node instead
[2]	OutAmpPrsnt	R	0x0	No output amp
[1]	InAmpPrsnt	R	0x0	No input amp
[0]	Stereo	R	0x1	Stereo widget

5.11.2. DigOutPin Cap

Table 126. DigOutPin Cap Command Verb Format

	Verb ID	Payload	Response
Get	F00	0C	See bitfield table

Table 127. DigOutPin Cap Command Response Format

Bit	Bitfield Name	RW	Reset	Description
[31:17]	Rsvd2	R	0x0	Reserved
[16]	EapđCap	R	0x0	This widget does not control EAPD pin

Table 127. DigOutPin Cap Command Response Format

Bit	Bitfield Name	RW	Reset	Description
[15:8]	VRefCntrl	R	0x00	VRef generation N/A since pin complex is not input capable.
[7]	Rsvd1	R	0x0	Reserved
[6]	BalancedIO	R	0x0	Pin complex does not have balanced pins.
[5]	InCap	R	0x0	Pin complex is not input capable.
[4]	OutCap	R	0x1	Pin complex is output capable.
[3]	HPhnDrvCap	R	0x0	Pin does not have a headphone amplifier.
[2]	PresDtctCap	R	0x0	Pin complex cannot perform Presence Detect.
[1]	TrigRqd	R	0x0	N/A
[0]	ImpSenseCap	R	0x0	Pin complex does not support impedance sense.

5.11.3. DigOutPin ConnLen

Table 128. DigOutPin ConnLen Command Verb Format

	Verb ID	Payload	Response
Get	F00	0E	See bitfield table

Table 129. DigOutPin ConnLen Command Response Format

Bit	Bitfield Name	RW	Reset	Description
[31:8]	Rsvd	R	0x0	Reserved.
[7]	LongForm	R	0x0	Connection list uses short-form (7-bit) NID entries.
[6:0]	N	R	0x02	Number of NID entries in connection list.

5.11.4. DigOutPin ConnSel

Table 130. DigOutPin ConnSel Command Verb Format

	Verb ID	Payload	Response
Get	F01	00	See bitfield table
Set1	701	See bits [7:0] of bitfield table	0000_0000h

Table 131. DigOutPin ConnSel Command Response Format

Bit	Bitfield Name	RW	Reset	Description
[31:2]	Rsvd	R	0x0	Reserved
[1:0]	Index	RW	0x0	Connection select control index.

5.11.5. DigOutPin ConnLst

Table 132. DigOutPin ConnLst Command Verb Format

	Verb ID	Payload	Response
Get	F02	00	See bitfield table

Table 133. DigOutPin ConnLst Command Response Format

Bit	Bitfield Name	RW	Reset	Description
[31:24]	Entry3	R	0x00	Unused list entry.
[23:16]	Entry2	R	0x00	Unused list entry.
[15:8]	Entry1	R	0x14	ADC0InMux widget.
[7:0]	Entry0	R	0x05	SPDIF Out converter widget.

5.11.6. *DigOutPin Ctl*

Table 134. DigOutPin Ctl Command Verb Format

	Verb ID	Payload	Response
Get	F07	00	See bitfield table
Set1	707	See bits [7:0] of bitfield table	0000_0000h

Table 135. DigOutPin Ctl Command Response Format

Bit	Bitfield Name	RW	Reset	Description
[31:7]	Rsvd2	R	0x0	Reserved
[6]	OutEn	RW	0x0	1 = (CODEC) output path of Pin Widget is enabled
[5:0]	Rsvd1	R	0x0	Reserved

5.11.7. *DigOutPin Config*

Table 136. DigOutPin Config Command Verb Format

	Verb ID	Payload	Response
Get	F1C	00	See bitfield table
Set1	71C	See bits [7:0] of bitfield table	0000_0000h
Set2	71D	See bits [15:8] of bitfield table	0000_0000h
Set3	71E	See bits [23:16] of bitfield table	0000_0000h
Set4	71F	See bits [31:24] of bitfield table	0000_0000h

Table 137. DigOutPin Config Command Response Format

Bit	Bitfield Name	RW	Reset	Description
[31:30]	Port	RW	0x0	External Port Connectivity of the Pin Complex. 0 = Port Complex is connected to a jack
[29:24]	Location	RW	0x01	Physical location of the jack. Optical jack at mainboard rear.

Table 137. DigOutPin Config Command Response Format

Bit	Bitfield Name	RW	Reset	Description
[23:20]	Device	RW	0x4	Default Device, indicating intended use of jack. 4 = SPDIF Out
[19:16]	Connection	RW	0x5	Connection Type. 5 = optical
[15:12]	Color	RW	0x1	Color of physical jack. 1 = Black
[11:8]	Misc	RW	0x1	Misc[0] = Jack Detect override.
[7:4]	Assoc	RW	0x3	Default Association for Pin Complex groups. Reserved value 0000b should not be used. Value 1111b indicates lowest priority.
[3:0]	Sequence	RW	0x0	All Widgets in an association must have unique sequence number.

5.12. ADC0VolMux Node (NID = 0x09)

5.12.1. ADC0VolMux VolRight

Table 138. ADC0VolMux VolRight Command Verb Format

	Verb ID	Payload	Response
Get	B80	00	See bitfield table
Set1	390	See bits [7:0] of bitfield table	0000_0000h

Table 139. ADC0VolMux VolRight Command Response Format

Bit	Bitfield Name	RW	Reset	Description
[31:4]	Rsvd1	R	0x0	Reserved
[3:0]	Gain	RW	0x0	Amplifier gain step number

5.12.2. ADC0VoIMux VoLeft

Table 140. ADC0VoIMux VoLeft Command Verb Format

	Verb ID	Payload	Response
Get	BA0	00	See bitfield table
Set1	3A0	See bits [7:0] of bitfield table	0000_0000h

Table 141. ADC0VoIMux VoLeft Command Response Format

Bit	Bitfield Name	RW	Reset	Description
[31:4]	Rsvd1	R	0x0	Reserved
[3:0]	Gain	RW	0x0	Amplifier gain step number

5.12.3. ADC0VoIMux WCap

Table 142. ADC0VoIMux WCap Command Verb Format

	Verb ID	Payload	Response
Get	F00	09	See bitfield table

Table 143. ADC0VoIMux WCap Command Response Format

Bit	Bitfield Name	RW	Reset	Description
[31:24]	Rsvd2	R	0x0	Reserved
[23:20]	Type	R	0x3	Widget type = Audio Selector
[19:16]	Delay	R	0x0	Number of sample delays through widget
[15:12]	Rsvd1	R	0x0	Reserved
[11]	SwapCap	R	0x0	No left/right swap capability
[10]	PwrCntrl	R	0x0	No support for Power State control
[9]	DigitalStrm	R	0x0	Widget supports an Analog stream
[8]	ConnList	R	0x1	Connection list is present

Table 143. ADC0VolMux WCap Command Response Format

Bit	Bitfield Name	RW	Reset	Description
[7]	UnsolCap	R	0x0	No support for Unsolicited Response
[6]	ProcWidget	R	0x0	No Processing Controls parameter.
[5]	Stripe	R	0x0	No support for striping
[4]	FormatOvrd	R	0x0	No format info; use default format parameters from Audio Function node instead
[3]	AmpParamOvrd	R	0x1	This widget contains its own amplifier parameters.
[2]	OutAmpPrsnt	R	0x1	Output amp is present
[1]	InAmpPrsnt	R	0x0	No input amp
[0]	Stereo	R	0x1	Stereo widget

5.12.4. ADC0VolMux OutAmpCap

Table 144. ADC0VolMux OutAmpCap Command Verb Format

	Verb ID	Payload	Response
Get	F00	12	See bitfield table

Table 145. ADC0VolMux OutAmpCap Command Response Format

Bit	Bitfield Name	RW	Reset	Description
[31]	Mute	R	0x0	Amplifier is not capable of muting
[30:23]	Rsvd3	R	0x0	Reserved
[22:16]	StepSize	R	0x05	Size of each step in the gain range = 1.5dB
[15]	Rsvd2	R	0x0	Reserved
[14:8]	NumSteps	R	0x0F	Number of steps in the gain range = 15 (16 values, 0dB to +22.5dB)
[7]	Rsvd1	R	0x0	Reserved
[6:0]	Offset	R	0x00	0dB-step is programmed with this offset

5.12.5. ADC0VoIMux ConnLen

Table 146. ADC0VoIMux ConnLen Command Verb Format

	Verb ID	Payload	Response
Get	F00	0E	See bitfield table

Table 147. ADC0VoIMux ConnLen Command Response Format

Bit	Bitfield Name	RW	Reset	Description
[31:8]	Rsvd	R	0x0	Reserved
[7]	LongForm	R	0x0	Connection list uses short-form (7-bit) NID entries.
[6:0]	N	R	0x01	Number of NID entries in connection list.

5.12.6. ADC0VoIMux ConnLst

Table 148. ADC0VoIMux ConnLst Command Verb Format

	Verb ID	Payload	Response
Get	F02	00	See bitfield table

Table 149. ADC0VoIMux ConnLst Command Response Format

Bit	Bitfield Name	RW	Reset	Description
[31:24]	Entry3	R	0x00	Unused list entry.
[23:16]	Entry2	R	0x00	Unused list entry.
[15:8]	Entry1	R	0x00	Unused list entry.
[7:0]	Entry0	R	0x0F	Input Port (UnivJack) Mux widget.

5.13. MasterVol Node (NID = 0x0E)

5.13.1. MasterVol Right

Table 150. MasterVol Right Command Verb Format

	Verb ID	Payload	Response
Get	B80	00	See bitfield table
Set1	390	See bits [7:0] of bitfield table	0000_0000h

Table 151. MasterVol Right Command Response Format

Bit	Bitfield Name	RW	Reset	Description
[31:8]	Rsvd2	R	0x0	Reserved
[7]	Mute	RW	0x1	1 = mute is active
[6:5]	Rsvd1	R	0x0	Reserved
[4:0]	Gain	RW	0x1F	Amplifier gain step number

5.13.2. MasterVol Left

Table 152. MasterVol Left Command Verb Format

	Verb ID	Payload	Response
Get	BA0	00	See bitfield table
Set1	3A0	See bits [7:0] of bitfield table	0000_0000h

Table 153. MasterVol Left Command Response Format

Bit	Bitfield Name	RW	Reset	Description
[31:8]	Rsvd2	R	0x0	Reserved
[7]	Mute	RW	0x1	1 = mute is active
[6:5]	Rsvd1	R	0x0	Reserved
[4:0]	Gain	RW	0x1F	Amplifier gain step number

5.13.3. MasterVol WCap

Table 154. MasterVol WCap Command Verb Format

	Verb ID	Payload	Response
Get	F00	09	See bitfield table

Table 155. MasterVol WCap Command Response Format

Bit	Bitfield Name	RW	Reset	Description
[31:24]	Rsvd2	R	0x0	Reserved
[23:20]	Type	R	0x3	Widget type = Audio Selector
[19:16]	Delay	R	0x0	Number of sample delays through widget
[15:12]	Rsvd1	R	0x0	Reserved
[11]	SwapCap	R	0x0	No left/right channel swap capability
[10]	PwrCntrl	R	0x0	No support for Power State control
[9]	DigitalStrm	R	0x0	Widget supports an Analog stream
[8]	ConnList	R	0x1	Connection list is present
[7]	UnsolCap	R	0x0	No support for Unsolicited Response
[6]	ProcWidget	R	0x0	No Processing Controls parameter.
[5]	Stripe	R	0x0	No support for striping
[4]	FormatOvrd	R	0x0	No format info; use default format parameters from Audio Function node instead
[3]	AmpParamOvrd	R	0x0	No amplifier info; use default amplifier parameters from Audio Function node instead
[2]	OutAmpPrsnt	R	0x1	Output amp is present
[1]	InAmpPrsnt	R	0x0	No input amp
[0]	Stereo	R	0x1	Stereo widget

5.13.4. MasterVol ConnLen

Table 156. MasterVol ConnLen Command Verb Format

	Verb ID	Payload	Response
Get	F00	0E	See bitfield table

Table 157. MasterVol ConnLen Command Response Format

Bit	Bitfield Name	RW	Reset	Description
[31:8]	Rsvd	R	0x0	Reserved
[7]	LongForm	R	0x0	Connection list uses short-form (7-bit) NID entries.
[6:0]	N	R	0x01	Number of NID entries in connection list.

5.13.5. MasterVol ConnLst

Table 158. MasterVol ConnLst Command Verb Format

	Verb ID	Payload	Response
Get	F02	00	See bitfield table

Table 159. MasterVol ConnLst Command Response Format

Bit	Bitfield Name	RW	Reset	Description
[31:24]	Entry3	R	0x00	Unused list entry.
[23:16]	Entry2	R	0x00	Unused list entry.
[15:8]	Entry1	R	0x00	Unused list entry.
[7:0]	Entry0	R	0x06	DAC Mux widget.

5.14. InPortMux Node (NID = 0x0F)

5.14.1. InPortMux VolRight

Table 160. InPortMux VolRight Command Verb Format

	Verb ID	Payload	Response
Get	B80	00	See bitfield table
Set1	390	See bits [7:0] of bitfield table	0000_0000h

Table 161. InPortMux VolRight Command Response Format

Bit	Bitfield Name	RW	Reset	Description
[31:3]	Rsvd	R	0x0	Reserved
[2:0]	Gain	RW	0x0	Amplifier gain step number

5.14.2. InPortMux VolLeft

Table 162. InPortMux VolLeft Command Verb Format

	Verb ID	Payload	Response
Get	BA0	00	See bitfield table
Set1	3A0	See bits [7:0] of bitfield table	0000_0000h

Table 163. InPortMux VolLeft Command Response Format

Bit	Bitfield Name	RW	Reset	Description
[31:3]	Rsvd	R	0x0	Reserved
[2:0]	Gain	RW	0x0	Amplifier gain step number

5.14.3. InPortMux WCap

Table 164. InPortMux WCap Command Verb Format

	Verb ID	Payload	Response
Get	F00	09	See bitfield table

Table 165. InPortMux WCap Command Response Format

Bit	Bitfield Name	RW	Reset	Description
[31:24]	Rsvd2	R	0x0	Reserved
[23:20]	Type	R	0x3	Widget type = Audio Selector
[19:16]	Delay	R	0x0	Number of sample delays through widget
[15:12]	Rsvd1	R	0x0	Reserved
[11]	SwapCap	R	0x0	No left/right channel swap capability
[10]	PwrCntrl	R	0x0	No support for Power State control
[9]	DigitalStrm	R	0x0	Widget supports an Analog stream
[8]	ConnList	R	0x1	Connection list is present
[7]	UnsolCap	R	0x0	No support for Unsolicited Response
[6]	ProcWidget	R	0x0	No Processing Controls parameter.
[5]	Stripe	R	0x0	No support for striping
[4]	FormatOvrd	R	0x0	No format info; use default format parameters from Audio Function node instead
[3]	AmpParamOvrd	R	0x1	This widget contains its own amplifier parameters.
[2]	OutAmpPrsnt	R	0x1	Output amp is present
[1]	InAmpPrsnt	R	0x0	No input amp
[0]	Stereo	R	0x1	Stereo widget

5.14.4. InPortMux ConnLen

Table 166. InPortMux ConnLen Command Verb Format

	Verb ID	Payload	Response
Get	F00	0E	See bitfield table

Table 167. InPortMux ConnLen Command Response Format

Bit	Bitfield Name	RW	Reset	Description
[31:8]	Rsvd	R	0x0	Reserved
[7]	LongForm	R	0x0	Connection list uses short-form (7-bit) NID entries.
[6:0]	N	R	0x05	Number of NID entries in connection list.

5.14.5. InPortMux AmpCap

Table 168. InPortMux AmpCap Command Verb Format

	Verb ID	Payload	Response
Get	F00	12	See bitfield table

Table 169. InPortMux AmpCap Command Response Format

Bit	Bitfield Name	RW	Reset	Description
[31]	Mute	R	0x0	No mute capability
[30:23]	Rsvd3	R	0x0	Reserved
[22:16]	StepSize	R	0x27	Size of each step in the gain range = 10dB
[15]	Rsvd2	R	0x0	Reserved
[14:8]	NumSteps	R	0x04	Number of steps in the gain range = 4 (5 values, 0dB to +40dB)
[7]	Rsvd1	R	0x0	Reserved
[6:0]	Offset	R	0x00	0dB-step is programmed with this offset

5.14.6. InPortMux ConnSel

Table 170. InPortMux ConnSel Command Verb Format

	Verb ID	Payload	Response
Get	F01	00	See bitfield table
Set1	701	See bits [7:0] of bitfield table	0000_0000h

Table 171. InPortMux ConnSel Command Response Format

Bit	Bitfield Name	RW	Reset	Description
[31:3]	Rsvd	R	0x0	Reserved
[2:0]	Index	RW	0x0	Connection select control index.

5.14.7. InPortMux ConnLst0

Table 172. InPortMux ConnLst0 Command Verb Format

	Verb ID	Payload	Response
Get	F02	00	See bitfield table

Table 173. InPortMux ConnLst0 Command Response Format

Bit	Bitfield Name	RW	Reset	Description
[31:24]	Entry3	R	0x0A	Port A pin widget.
[23:16]	Entry2	R	0x0D	Port D pin widget.
[15:8]	Entry1	R	0x0C	Port C pin widget.
[7:0]	Entry0	R	0x0B	Port B pin widget.

5.14.8. InPortMux ConnLst4

Table 174. InPortMux ConnLst4 Command Verb Format

	Verb ID	Payload	Response
Get	F02	04	See bitfield table

Table 175. InPortMux ConnLst4 Command Response Format

Bit	Bitfield Name	RW	Reset	Description
[31:24]	Entry3	R	0x00	Unused list entry.
[23:16]	Entry2	R	0x00	Unused list entry.
[15:8]	Entry1	R	0x00	Unused list entry.
[7:0]	Entry0	R	0x11	CDin pin widget.

5.15. PortAPin Node (NID = 0x0A)

5.15.1. PortAPin WCap

Table 176. PortAPin WCap Command Verb Format

	Verb ID	Payload	Response
Get	F00	09	See bitfield table

Table 177. PortAPin WCap Command Response Format

Bit	Bitfield Name	RW	Reset	Description
[31:24]	Rsvd2	R	0x0	Reserved
[23:20]	Type	R	0x4	Widget type = Pin Complex
[19:16]	Delay	R	0x0	Number of sample delays through widget
[15:12]	Rsvd1	R	0x0	Reserved
[11]	SwapCap	R	0x0	No left/right channel swap capability
[10]	PwrCntrl	R	0x0	No support for Power State control
[9]	DigitalStrm	R	0x0	Widget supports an Analog stream
[8]	ConnList	R	0x1	Connection list is present
[7]	UnsolCap	R	0x1	Unsolicited Response is supported
[6]	ProcWidget	R	0x0	No Processing Controls parameter

Table 177. PortAPin WCap Command Response Format

Bit	Bitfield Name	RW	Reset	Description
[5]	Stripe	R	0x0	No support for striping
[4]	FormatOvrd	R	0x0	N/A for pin complex
[3]	AmpParamOvrd	R	0x0	No amplifier info; use default amplifier parameters from Audio Function node instead.
[2]	OutAmpPrsnt	R	0x0	No output amp
[1]	InAmpPrsnt	R	0x0	No input amp
[0]	Stereo	R	0x1	Stereo widget

5.15.2. PortAPin Cap

Table 178. PortAPin Cap Command Verb Format

	Verb ID	Payload	Response
Get	F00	0C	See bitfield table

Table 179. PortAPin Cap Command Response Format

Bit	Bitfield Name	RW	Reset	Description
[31:17]	Rsvd2	R	0x0	Reserved
[16]	EapdCap	R	0x0	This widget does not control EAPD pin
[15:8]	VRefCntrl	R	0x00	VRef generation not supported by this pin complex.
[7]	Rsvd1	R	0x0	Reserved
[6]	BalancedIO	R	0x0	Pin complex does not have balanced pins.
[5]	InCap	R	0x1	Pin complex is input capable.
[4]	OutCap	R	0x1	Pin complex is output capable.
[3]	HPhnDrvCap	R	0x1	Pin complex has headphone amplifier.
[2]	PresDtctCap	R	0x1	Pin complex can perform Presence Detect.

Table 179. PortAPin Cap Command Response Format

Bit	Bitfield Name	RW	Reset	Description
[1]	TrigRqd	R	0x1	Trigger is required for impedance measurement
[0]	ImpSenseCap	R	0x1	Pin complex supports impedance sense.

5.15.3. PortAPin ConnLen

Table 180. PortAPin ConnLen Command Verb Format

	Verb ID	Payload	Response
Get	F00	0E	See bitfield table

Table 181. PortAPin ConnLen Command Response Format

Bit	Bitfield Name	RW	Reset	Description
[31:8]	Rsvd	R	0x0	Reserved.
[7]	LongForm	R	0x0	Connection list uses short-form (7-bit) NID entries.
[6:0]	N	R	0x01	Number of NID entries in connection list.

5.15.4. PortAPin ConnLst

Table 182. PortAPin ConnLst Command Verb Format

	Verb ID	Payload	Response
Get	F02	00	See bitfield table

Table 183. PortAPin ConnLst Command Response Format

Bit	Bitfield Name	RW	Reset	Description
[31:24]	Entry3	R	0x00	Unused list entry.
[23:16]	Entry2	R	0x00	Unused list entry.
[15:8]	Entry1	R	0x00	Unused list entry.
[7:0]	Entry0	R	0x0E	Master Volume widget.

5.15.5. *PortAPin Ctl*

Table 184. PortAPin Ctl Command Verb Format

	Verb ID	Payload	Response
Get	F07	00	See bitfield table
Set1	707	See bits [7:0] of bitfield table	0000_0000h

Table 185. PortAPin Ctl Command Response Format

Bit	Bitfield Name	RW	Reset	Description
[31:8]	Rsvd2	R	0x0	Reserved
[7]	HPhnEn	RW	0x0	1 = enable the low impedance amplifier associated with the output
[6]	OutEn	RW	0x0	1 = (CODEC) output path of Pin Widget is enabled
[5]	InEn	RW	0x0	1 = (CODEC) input path of Pin Widget is enabled
[4:0]	Rsvd1	R	0x0	Reserved

5.15.6. *PortAPin UnsolicitedResp*

Table 186. PortAPin UnsolicitedResp Command Verb Format

	Verb ID	Payload	Response
Get	F08	00	See bitfield table
Set1	708	See bits [7:0] of bitfield table	0000_0000h

Table 187. PortAPin UnsolicitedResp Command Response Format

Bit	Bitfield Name	RW	Reset	Description
[31:8]	Rsvd2	R	0x00	Reserved
[7]	En	RW	0x0	Allow generation of Unsolicited Responses. Unsolicited response events occur upon jack-insertion OR completion of a Jack-Sense cycle.

Table 187. PortAPin Unsolicited Command Response Format

Bit	Bitfield Name	RW	Reset	Description
[6]	Rsvd1	R	0x0	Reserved
[5:0]	Tag	RW	0x00	Software programmable field returned in top six bits (31:26) of every Unsolicited Response generated by this node.

5.15.7. PortAPin Sense

Table 188. PortAPin Sense Command Verb Format

	Verb ID	Payload	Response
Get	F09	00	See bitfield table
Set1	709	See bits [7:0] of bitfield table	0000_0000h
Set2	709	See bits [7:0] of bitfield table	0000_0000h

Table 189. PortAPin Sense Command Response Format

Bit	Bitfield Name	RW	Reset	Description
[31]	Present	R	0x0	1 = something is plugged into jack associated with Pin Complex.
[30:0]	Impedance	R	0x7FFF_FFFF	Measured impedance of the widget. A value of all 1's indicates that a valid sense reading is not available, or the sense measurement is busy if it has been recently triggered. Overlaps RightCh.
[0]	RightCh	W	0x0	Set 1 = perform impedance sensing on right channel or ring of the connector
[0]	LeftCh	W	0x0	Set 0 = perform impedance sensing on left channel or tip of the connector

5.15.8. PortAPin Config

Table 190. PortAPin Config Command Verb Format

	Verb ID	Payload	Response
Get	F1C	00	See bitfield table
Set1	71C	See bits [7:0] of bitfield table	0000_0000h
Set2	71D	See bits [15:8] of bitfield table	0000_0000h
Set3	71E	See bits [23:16] of bitfield table	0000_0000h
Set4	71F	See bits [31:24] of bitfield table	0000_0000h

Table 191. PortAPin Config Command Response Format

Bit	Bitfield Name	RW	Reset	Description
[31:30]	Port	RW	0x0	External Port Connectivity of the Pin Complex. 0 = Port Complex is connected to a jack
[29:24]	Location	RW	0x02	Physical location of the jack. 02h = Mainboard, Front
[23:20]	Device	RW	0x2	Default Device, indicating intended use of jack. 2 = HP Out
[19:16]	Connection	RW	0x1	Connection Type. 1 = 1/8 inch jack
[15:12]	Color	RW	0x4	Color of physical jack. 4 = Green
[11:8]	Misc	RW	0x0	Misc[0] = Jack Detect override.
[7:4]	Assoc	RW	0x1	Default Association for Pin Complex groups. Reserved value 0000b should not be used. Value 1111b indicates lowest priority.
[3:0]	Sequence	RW	0xF	All Widgets in an association must have unique sequence number.

5.16. PortDPin Node (NID = 0x0D)

5.16.1. PortDPin WCap

Table 192. PortDPin WCap Command Verb Format

	Verb ID	Payload	Response
Get	F00	09	See bitfield table

Table 193. PortDPin WCap Command Response Format

Bit	Bitfield Name	RW	Reset	Description
[31:24]	Rsvd2	R	0x0	Reserved
[23:20]	Type	R	0x4	Widget type = Pin Complex
[19:16]	Delay	R	0x0	Number of sample delays through widget
[15:12]	Rsvd1	R	0x0	Reserved
[11]	SwapCap	R	0x0	No left/right channel swap capability
[10]	PwrCntrl	R	0x0	No support for Power State control
[9]	DigitalStrm	R	0x0	Widget supports an Analog stream
[8]	ConnList	R	0x1	Connection list is present
[7]	UnsolCap	R	0x1	Unsolicited Response is supported
[6]	ProcWidget	R	0x0	No Processing Controls parameter
[5]	Stripe	R	0x0	No support for striping
[4]	FormatOvrd	R	0x0	N/A for pin complex
[3]	AmpParamOvrd	R	0x0	No amplifier info; use default amplifier parameters from Audio Function node instead.
[2]	OutAmpPrsnt	R	0x0	No output amp
[1]	InAmpPrsnt	R	0x0	No input amp
[0]	Stereo	R	0x1	Stereo widget

5.16.2. *PortDPin Cap*

Table 194. PortDPin Cap Command Verb Format

	Verb ID	Payload	Response
Get	F00	0C	See bitfield table

Table 195. PortDPin Cap Command Response Format

Bit	Bitfield Name	RW	Reset	Description
[31:17]	Rsvd2	R	0x0	Reserved2
[16]	EapdCap	R	0x0	This widget does not control EAPD pin
[15:8]	VRefCntrl	R	0x00	VRef generation not supported by this pin complex.
[7]	Rsvd1	R	0x0	Reserved
[6]	BalancedIO	R	0x0	Pin complex does not have balanced pins.
[5]	InCap	R	0x1	Pin complex is input capable.
[4]	OutCap	R	0x1	Pin complex is output capable.
[3]	HPhnDrvCap	R	0x1	Pin complex has headphone amplifier.
[2]	PresDtctCap	R	0x1	Pin complex can perform Presence Detect.
[1]	TrigRqd	R	0x1	Trigger is required for impedance measurement
[0]	ImpSenseCap	R	0x1	Pin complex supports impedance sense.

5.16.3. *PortDPin ConnLen*

Table 196. PortDPin ConnLen Command Verb Format

	Verb ID	Payload	Response
Get	F00	0E	See bitfield table

Table 197. PortDPin ConnLen Command Response Format

Bit	Bitfield Name	RW	Reset	Description
[31:8]	Rsvd	R	0x0	Reserved.
[7]	LongForm	R	0x0	Connection list uses short-form (7-bit) NID entries.
[6:0]	N	R	0x01	Number of NID entries in connection list.

5.16.4. PortDPin ConnLst

Table 198. PortDPin ConnLst Command Verb Format

	Verb ID	Payload	Response
Get	F02	00	See bitfield table

Table 199. PortDPin ConnLst Command Response Format

Bit	Bitfield Name	RW	Reset	Description
[31:24]	Entry3	R	0x00	Unused list entry.
[23:16]	Entry2	R	0x00	Unused list entry.
[15:8]	Entry1	R	0x00	Unused list entry.
[7:0]	Entry0	R	0x0E	Master Volume widget.

5.16.5. PortDPin Ctl

Table 200. PortDPin Ctl Command Verb Format

	Verb ID	Payload	Response
Get	F07	00	See bitfield table
Set1	707	See bits [7:0] of bitfield table	0000_0000h

Table 201. PortDPin Ctl Command Response Format

Bit	Bitfield Name	RW	Reset	Description
[31:8]	Rsvd2	R	0x0	Reserved
[7]	HPhnEn	RW	0x0	1 = enable the low impedance amplifier associated with the output
[6]	OutEn	RW	0x0	1 = (CODEC) output path of Pin Widget is enabled
[5]	InEn	RW	0x0	1 = (CODEC) input path of Pin Widget is enabled
[4:0]	Rsvd1	R	0x0	Reserved

5.16.6. PortDPin Unsolicited Response

Table 202. PortDPin Unsolicited Response Command Verb Format

	Verb ID	Payload	Response
Get	F08	00	See bitfield table
Set1	708	See bits [7:0] of bitfield table	0000_0000h

Table 203. PortDPin Unsolicited Response Command Response Format

Bit	Bitfield Name	RW	Reset	Description
[31:8]	Rsvd2	R	0x00	Reserved
[7]	En	RW	0x0	Allow generation of Unsolicited Responses. Unsolicited response events occur upon jack-insertion OR completion of a Jack-Sense cycle.
[6]	Rsvd1	R	0x0	Reserved
[5:0]	Tag	RW	0x00	Software programmable field returned in top six bits (31:26) of every Unsolicited Response generated by this node.

5.16.7. PortDPin Sense

Table 204. PortDPin Sense Command Verb Format

	Verb ID	Payload	Response
Get	F09	00	See bitfield table
Set1	709	See bits [7:0] of bitfield table	0000_0000h
Set2	709	See bits [7:0] of bitfield table	0000_0000h

Table 205. PortDPin Sense Command Response Format

Bit	Bitfield Name	RW	Reset	Description
[31]	Present	R	0x0	1 = something is plugged into jack associated with Pin Complex.
[30:0]	Impedance	R	0x7FFF_FFFF	Measured impedance of the widget. A value of all 1's indicates that a valid sense reading is not available, or the sense measurement is busy if it has been recently triggered. Overlaps RightCh.
[0]	RightCh	W	0x0	Set 1 = perform impedance sensing on right channel or ring of the connector
[0]	LeftCh	W	0x0	Set 0 = perform impedance sensing on left channel or tip of the connector

5.16.8. PortDPin Config

Table 206. PortDPin Config Command Verb Format

	Verb ID	Payload	Response
Get	F1C	00	See bitfield table
Set1	71C	See bits [7:0] of bitfield table	0000_0000h
Set2	71D	See bits [15:8] of bitfield table	0000_0000h
Set3	71E	See bits [23:16] of bitfield table	0000_0000h
Set4	71F	See bits [31:24] of bitfield table	0000_0000h

Table 207. PortDPin Config Command Response Format

Bit	Bitfield Name	RW	Reset	Description
[31:30]	Port	RW	0x0	External Port Connectivity of the Pin Complex. 0 = Port Complex is connected to a jack
[29:24]	Location	RW	0x01	Physical location of the jack. 01h = Mainboard, Rear
[23:20]	Device	RW	0x0	Default Device, indicating intended use of jack. 0 = Line Out
[19:16]	Connection	RW	0x1	Connection Type. 1 = 1/8 inch jack
[15:12]	Color	RW	0x4	Color of physical jack. 4 = Green
[11:8]	Misc	RW	0x0	Misc[0] = Jack Detect override.
[7:4]	Assoc	RW	0x1	Default Association for Pin Complex groups. Reserved value 0000b should not be used. Value 1111b indicates lowest priority.
[3:0]	Sequence	RW	0x0	All Widgets in an association must have unique sequence number.

5.17. PortCPin Node (NID = 0x0C)

5.17.1. PortCPin WCap

Table 208. PortCPin WCap Command Verb Format

	Verb ID	Payload	Response
Get	F00	09	See bitfield table

Table 209. PortCPin WCap Command Response Format

Bit	Bitfield Name	RW	Reset	Description
[31:24]	Rsvd2	R	0x0	Reserved
[23:20]	Type	R	0x4	Widget type = Pin Complex

Table 209. PortCPin WCap Command Response Format

Bit	Bitfield Name	RW	Reset	Description
[19:16]	Delay	R	0x0	Number of sample delays through widget
[15:12]	Rsvd1	R	0x0	Reserved
[11]	SwapCap	R	0x0	No left/right channel swap capability
[10]	PwrCntrl	R	0x0	No support for Power State control
[9]	DigitalStrm	R	0x0	Widget supports an Analog stream
[8]	ConnList	R	0x1	Connection list is present
[7]	UnsolCap	R	0x1	Unsolicited Response is supported
[6]	ProcWidget	R	0x0	No Processing Controls parameter
[5]	Stripe	R	0x0	No support for striping
[4]	FormatOvrd	R	0x0	N/A for pin complex
[3]	AmpParamOvrd	R	0x0	No amplifier info; use default amplifier parameters from Audio Function node instead.
[2]	OutAmpPrsnt	R	0x0	No output amp
[1]	InAmpPrsnt	R	0x0	No input amp
[0]	Stereo	R	0x1	Stereo widget

5.17.2. PortCPin Cap

Table 210. PortCPin Cap Command Verb Format

	Verb ID	Payload	Response
Get	F00	0C	See bitfield table

Table 211. PortCPin Cap Command Response Format

Bit	Bitfield Name	RW	Reset	Description
[31:17]	Rsvd2	R	0x0	Reserved2
[16]	EapdCap	R	0x0	This widget does not control EAPD pin

Table 211. PortCPin Cap Command Response Format

Bit	Bitfield Name	RW	Reset	Description
[15:8]	VRefCntrl	R	0x17	VRef generation is supported by this pin complex, and the following voltages can be produced on the associated VRef pin: 80% Avdd; 50% Avdd; GND; Hi-Z (required since pin complex is output capable)
[7]	Rsvd1	R	0x0	Reserved
[6]	BalancedIO	R	0x0	Pin complex does not have balanced pins.
[5]	InCap	R	0x1	Pin complex is input capable.
[4]	OutCap	R	0x1	Pin complex is output capable.
[3]	HPhnDrvCap	R	0x0	Pin does not have a headphone amplifier.
[2]	PresDtctCap	R	0x1	Pin complex can perform Presence Detect.
[1]	TrigRqd	R	0x1	Trigger is required for impedance measurement
[0]	ImpSenseCap	R	0x1	Pin complex supports impedance sense.

5.17.3. PortCPin ConnLen

Table 212. PortCPin ConnLen Command Verb Format

	Verb ID	Payload	Response
Get	F00	0E	See bitfield table

Table 213. PortCPin ConnLen Command Response Format

Bit	Bitfield Name	RW	Reset	Description
[31:8]	Rsvd	R	0x0	Reserved
[7]	LongForm	R	0x0	Connection list uses short-form (7-bit) NID entries.
[6:0]	N	R	0x01	Number of NID entries in connection list.

5.17.4. *PortCPin ConnLst*

Table 214. PortCPin ConnLst Command Verb Format

	Verb ID	Payload	Response
Get	F02	00	See bitfield table

Table 215. PortCPin ConnLst Command Response Format

Bit	Bitfield Name	RW	Reset	Description
[31:24]	Entry3	R	0x00	Unused list entry.
[23:16]	Entry2	R	0x00	Unused list entry.
[15:8]	Entry1	R	0x00	Unused list entry.
[7:0]	Entry0	R	0x0E	Master Volume widget.

5.17.5. *PortCPin Ctl*

Table 216. PortCPin Ctl Command Verb Format

	Verb ID	Payload	Response
Get	F07	00	See bitfield table
Set1	707	See bits [7:0] of bitfield table	0000_0000h

Table 217. PortCPin Ctl Command Response Format

Bit	Bitfield Name	RW	Reset	Description
[31:7]	Rsvd2	R	0x0	Reserved
[6]	OutEn	RW	0x0	1 = (CODEC) output path of Pin Widget is enabled
[5]	InEn	RW	0x1	1 = (CODEC) input path of Pin Widget is enabled

Table 217. PortCPin Ctl Command Response Format

Bit	Bitfield Name	RW	Reset	Description
[4:3]	Rsvd1	R	0x0	Reserved
[2:0]	VRefSelect	RW	0x0	VRefEn: Selects one of the possible states for the VRef signal associated with the Pin Widget. If the value written to this control does not correspond to a supported value defined in the VRefCntrl field of the Pin Capabilities parameter (0C), then this control will take the value of 000b (Hi-Z).

5.17.6. PortCPin UnsolResp

Table 218. PortCPin UnsolResp Command Verb Format

	Verb ID	Payload	Response
Get	F08	00	See bitfield table
Set1	708	See bits [7:0] of bitfield table	0000_0000h

Table 219. PortCPin UnsolResp Command Response Format

Bit	Bitfield Name	RW	Reset	Description
[31:8]	Rsvd2	R	0x00	Reserved
[7]	En	RW	0x0	Allow generation of Unsolicited Responses. Unsolicited response events occur upon jack-insertion OR completion of a Jack-Sense cycle.
[6]	Rsvd1	R	0x0	Reserved
[5:0]	Tag	RW	0x00	Software programmable field returned in top six bits (31:26) of every Unsolicited Response generated by this node.

5.17.7. PortCPin Sense

Table 220. PortCPin Sense Command Verb Format

	Verb ID	Payload	Response
Get	F09	00	See bitfield table
Set1	709	See bits [7:0] of bitfield table	0000_0000h
Set2	709	See bits [7:0] of bitfield table	0000_0000h

Table 221. PortCPin Sense Command Response Format

Bit	Bitfield Name	RW	Reset	Description
[31]	Present	R	0x0	1 = something is plugged into jack associated with Pin Complex.
[30:0]	Impedance	R	0x7FFF_FFFF	Measured impedance of the widget. A value of all 1's indicates that a valid sense reading is not available, or the sense measurement is busy if it has been recently triggered. Overlaps RightCh.
[0]	RightCh	W	0x0	Set 1 = perform impedance sensing on right channel or ring of the connector
[0]	LeftCh	W	0x0	Set 0 = perform impedance sensing on left channel or tip of the connector

5.17.8. PortCPin Config

Table 222. PortCPin Config Command Verb Format

	Verb ID	Payload	Response
Get	F1C	00	See bitfield table
Set1	71C	See bits [7:0] of bitfield table	0000_0000h
Set2	71D	See bits [15:8] of bitfield table	0000_0000h
Set3	71E	See bits [23:16] of bitfield table	0000_0000h
Set4	71F	See bits [31:24] of bitfield table	0000_0000h

Table 223. PortCPin Config Command Response Format

Bit	Bitfield Name	RW	Reset	Description
[31:30]	Port	RW	0x0	External Port Connectivity of the Pin Complex. 0 = Port Complex is connected to a jack
[29:24]	Location	RW	0x01	Physical location of the jack. 03h = Mainboard, Rear
[23:20]	Device	RW	0x8	Default Device, indicating intended use of jack. 8 = Line In
[19:16]	Connection	RW	0x1	Connection Type. 1 = 1/8 inch jack
[15:12]	Color	RW	0x3	Color of physical jack. 3 = Blue
[11:8]	Misc	RW	0x0	Misc[0] = Jack Detect override.
[7:4]	Assoc	RW	0x2	Default Association for Pin Complex groups. Reserved value 0000b should not be used. Value 1111b indicates lowest priority.
[3:0]	Sequence	RW	0x1	All Widgets in an association must have unique sequence number.

5.18. PortBPin Node (NID = 0x0B)

5.18.1. PortBPin WCap

Table 224. PortBPin WCap Command Verb Format

	Verb ID	Payload	Response
Get	F00	09	See bitfield table

Table 225. PortBPin WCap Command Response Format

Bit	Bitfield Name	RW	Reset	Description
[31:24]	Rsvd2	R	0x0	Reserved
[23:20]	Type	R	0x4	Widget type = Pin Complex
[19:16]	Delay	R	0x0	Number of sample delays through widget

Table 225. PortBPin WCap Command Response Format

Bit	Bitfield Name	RW	Reset	Description
[15:12]	Rsvd1	R	0x0	Reserved
[11]	SwapCap	R	0x0	No left/right channel swap capability
[10]	PwrCntrl	R	0x0	No support for Power State control
[9]	DigitalStrm	R	0x0	Widget supports an Analog stream
[8]	ConnList	R	0x1	Connection list is present
[7]	UnsolCap	R	0x1	Unsolicited Response is supported
[6]	ProcWidget	R	0x0	No Processing Controls parameter
[5]	Stripe	R	0x0	No support for striping
[4]	FormatOvrd	R	0x0	N/A for pin complex
[3]	AmpParamOvrd	R	0x0	No amplifier info; use default amplifier parameters from Audio Function node instead.
[2]	OutAmpPrsnt	R	0x0	No output amp
[1]	InAmpPrsnt	R	0x0	No input amp
[0]	Stereo	R	0x1	Stereo widget

5.18.2. PortBPin Cap

Table 226. PortBPin Cap Command Verb Format

	Verb ID	Payload	Response
Get	F00	0C	See bitfield table

Table 227. PortBPin Cap Command Response Format

Bit	Bitfield Name	RW	Reset	Description
[31:17]	Rsvd2	R	0x0	Reserved
[16]	EapdCap	R	0x0	This widget does not control EAPD pin

Table 227. PortBPin Cap Command Response Format

Bit	Bitfield Name	RW	Reset	Description
[15:8]	VRefCntrl	R	0x17	VRef generation is supported by this pin complex, and the following voltages can be produced on the associated VRef pin: 80% Avdd; 50% Avdd; GND; Hi-Z (required since pin complex is output capable)
[7]	Rsvd1	R	0x0	Reserved
[6]	BalancedIO	R	0x0	Pin complex does not have balanced pins.
[5]	InCap	R	0x1	Pin complex is input capable.
[4]	OutCap	R	0x1	Pin complex is output capable.
[3]	HPhnDrvCap	R	0x0	Pin does not have a headphone amplifier.
[2]	PresDtctCap	R	0x1	Pin complex can perform Presence Detect.
[1]	TrigRqd	R	0x1	Trigger is required for impedance measurement
[0]	ImpSenseCap	R	0x1	Pin complex supports impedance sense.

5.18.3. PortBPin ConnLen

Table 228. PortBPin ConnLen Command Verb Format

	Verb ID	Payload	Response
Get	F00	0E	See bitfield table

Table 229. PortBPin ConnLen Command Response Format

Bit	Bitfield Name	RW	Reset	Description
[31:8]	Rsvd	R	0x0	Reserved.
[7]	LongForm	R	0x0	Connection list uses short-form (7-bit) NID entries.
[6:0]	N	R	0x01	Number of NID entries in connection list.

5.18.4. PortBPin ConnLst

Table 230. PortBPin ConnLst Command Verb Format

	Verb ID	Payload	Response
Get	F02	00	See bitfield table

Table 231. PortBPin ConnLst Command Response Format

Bit	Bitfield Name	RW	Reset	Description
[31:24]	Entry3	R	0x00	Unused list entry.
[23:16]	Entry2	R	0x00	Unused list entry.
[15:8]	Entry1	R	0x00	Unused list entry.
[7:0]	Entry0	R	0x0E	Master Volume widget.

5.18.5. PortBPin Ctl

Table 232. PortBPin Ctl Command Verb Format

	Verb ID	Payload	Response
Get	F07	00	See bitfield table
Set1	707	See bits [7:0] of bitfield table	0000_0000h

Table 233. PortBPin Ctl Command Response Format

Bit	Bitfield Name	RW	Reset	Description
[31:7]	Rsvd2	R	0x0	Reserved
[6]	OutEn	RW	0x0	1 = (CODEC) output path of Pin Widget is enabled
[5]	InEn	RW	0x1	1 = (CODEC) input path of Pin Widget is enabled

Table 233. PortBPin Ctl Command Response Format

Bit	Bitfield Name	RW	Reset	Description
[4:3]	Rsvd1	R	0x0	Reserved
[2:0]	VRefSelect	RW	0x0	VRefEn: Selects one of the possible states for the VRef signal associated with the Pin Widget. If the value written to this control does not correspond to a supported value defined in the VRefCntrl field of the Pin Capabilities parameter (0C), then this control will take the value of 000b (Hi-Z).

5.18.6. PortBPin Unsolicited Response

Table 234. PortBPin Unsolicited Response Command Verb Format

	Verb ID	Payload	Response
Get	F08	00	See bitfield table
Set1	708	See bits [7:0] of bitfield table	0000_0000h

Table 235. PortBPin Unsolicited Response Command Response Format

Bit	Bitfield Name	RW	Reset	Description
[31:8]	Rsvd2	R	0x00	Reserved
[7]	En	RW	0x0	Allow generation of Unsolicited Responses. Unsolicited response events occur upon jack-insertion OR completion of a Jack-Sense cycle.
[6]	Rsvd1	R	0x0	Reserved
[5:0]	Tag	RW	0x00	Software programmable field returned in top six bits (31:26) of every Unsolicited Response generated by this node.

5.18.7. PortBPin Sense

Table 236. PortBPin Sense Command Verb Format

	Verb ID	Payload	Response
Get	F09	00	See bitfield table
Set1	709	See bits [7:0] of bitfield table	0000_0000h
Set2	709	See bits [7:0] of bitfield table	0000_0000h

Table 237. PortBPin Sense Command Response Format

Bit	Bitfield Name	RW	Reset	Description
[31]	Present	R	0x0	1 = something is plugged into jack associated with Pin Complex.
[30:0]	Impedance	R	0x7FFF_FFFF	Measured impedance of the widget. A value of all 1's indicates that a valid sense reading is not available, or the sense measurement is busy if it has been recently triggered. Overlaps RightCh.
[0]	RightCh	W	0x0	Set 1 = perform impedance sensing on right channel or ring of the connector
[0]	LeftCh	W	0x0	Set 0 = perform impedance sensing on left channel or tip of the connector

5.18.8. PortBPin Config

Table 238. PortBPin Config Command Verb Format

	Verb ID	Payload	Response
Get	F1C	00	See bitfield table
Set1	71C	See bits [7:0] of bitfield table	0000_0000h
Set2	71D	See bits [15:8] of bitfield table	0000_0000h
Set3	71E	See bits [23:16] of bitfield table	0000_0000h
Set4	71F	See bits [31:24] of bitfield table	0000_0000h

Table 239. PortBPin Config Command Response Format

Bit	Bitfield Name	RW	Reset	Description
[31:30]	Port	RW	0x0	External Port Connectivity of the Pin Complex. 0 = Port Complex is connected to a jack
[29:24]	Location	RW	0x02	Physical location of the jack. 02h = Mainboard, Front
[23:20]	Device	RW	0xA	Default Device, indicating intended use of jack. A = Mic In
[19:16]	Connection	RW	0x1	Connection Type. 1 = 1/8 inch jack
[15:12]	Color	RW	0x9	Color of physical jack. 9 = Pink
[11:8]	Misc	RW	0x0	Misc[0] = Jack Detect override.
[7:4]	Assoc	RW	0x2	Default Association for Pin Complex groups. Reserved value 0000b should not be used. Value 1111b indicates lowest priority.
[3:0]	Sequence	RW	0x0	All Widgets in an association must have unique sequence number.

5.19. MonoOutPin Node (NID = 0x10)

5.19.1. MonoOutPin Vol

Table 240. MonoOutPin Vol Command Verb Format

	Verb ID	Payload	Response
Get	BA0	00	See bitfield table
Set1	3A0	See bits [7:0] of bitfield table	0000_0000h

Table 241. MonoOutPin Vol Command Response Format

Bit	Bitfield Name	RW	Reset	Description
[31:8]	Rsvd2	R	0x0	Reserved
[7]	Mute	RW	0x1	1 = mute is active

Table 241. MonoOutPin Vol Command Response Format

Bit	Bitfield Name	RW	Reset	Description
[6:5]	Rsvd1	R	0x0	Reserved
[4:0]	Gain	RW	0x1F	Mono (left) amplifier gain step number

5.19.2. MonoOutPin WCap

Table 242. MonoOutPin WCap Command Verb Format

	Verb ID	Payload	Response
Get	F00	09	See bitfield table

Table 243. MonoOutPin WCap Command Response Format

Bit	Bitfield Name	RW	Reset	Description
[31:24]	Rsvd2	R	0x0	Reserved
[23:20]	Type	R	0x4	Widget type = Pin Complex
[19:16]	Delay	R	0x0	Number of sample delays through widget
[15:12]	Rsvd1	R	0x0	Reserved
[11]	SwapCap	R	0x0	No left/right channel swap capability
[10]	PwrCntrl	R	0x0	No support for Power State control
[9]	DigitalStrm	R	0x0	Widget supports an Analog stream
[8]	ConnList	R	0x1	Connection list is present
[7]	UnsolCap	R	0x0	No support for Unsolicited Response
[6]	ProcWidget	R	0x0	No Processing Controls parameter
[5]	Stripe	R	0x0	No support for striping
[4]	FormatOvrd	R	0x0	N/A for pin complex
[3]	AmpParamOvrd	R	0x0	No amplifier info; use default amplifier parameters from Audio Function node instead.
[2]	OutAmpPrsnt	R	0x1	Output amp is present

Table 243. MonoOutPin WCap Command Response Format

Bit	Bitfield Name	RW	Reset	Description
[1]	InAmpPrsnt	R	0x0	No input amp
[0]	Stereo	R	0x0	Mono widget

5.19.3. MonoOutPin Cap

Table 244. MonoOutPin Cap Command Verb Format

	Verb ID	Payload	Response
Get	F00	0C	See bitfield table

Table 245. MonoOutPin Cap Command Response Format

Bit	Bitfield Name	RW	Reset	Description
[31:17]	Rsvd2	R	0x0	Reserved
[16]	EapdCap	R	0x0	This widget does not control EAPD pin
[15:8]	VRefCntrl	R	0x00	VRef generation N/A since pin complex is not input capable.
[7]	Rsvd1	R	0x0	Reserved
[6]	BalancedIO	R	0x0	Pin complex does not have balanced pins.
[5]	InCap	R	0x0	Pin complex is not input capable.
[4]	OutCap	R	0x1	Pin complex is output capable.
[3]	HPHnDrvCap	R	0x0	Pin does not have a headphone amplifier.
[2]	PresDtctCap	R	0x0	Pin complex cannot perform Presence Detect.
[1]	TrigRqd	R	0x0	N/A
[0]	ImpSenseCap	R	0x0	Pin complex does not support impedance sense.

5.19.4. MonoOutPin ConnLen

Table 246. MonoOutPin ConnLen Command Verb Format

	Verb ID	Payload	Response
Get	F00	0E	See bitfield table

Table 247. MonoOutPin ConnLen Command Response Format

Bit	Bitfield Name	RW	Reset	Description
[31:8]	Rsvd	R	0x0	Reserved
[7]	LongForm	R	0x0	Connection list uses short-form (7-bit) NID entries.
[6:0]	N	R	0x01	Number of NID entries in connection list.

5.19.5. MonoOutPin ConnLst

Table 248. MonoOutPin ConnLst Command Verb Format

	Verb ID	Payload	Response
Get	F02	00	See bitfield table

Table 249. MonoOutPin ConnLst Command Response Format

Bit	Bitfield Name	RW	Reset	Description
[31:24]	Entry3	R	0x00	Unused list entry.
[23:16]	Entry2	R	0x00	Unused list entry.
[15:8]	Entry1	R	0x00	Unused list entry.
[7:0]	Entry0	R	0x12	MonoOut Mix widget.

5.19.6. MonoOutPin Ctl

Table 250. MonoOutPin Ctl Command Verb Format

	Verb ID	Payload	Response
Get	F07	00	See bitfield table
Set1	707	See bits [7:0] of bitfield table	0000_0000h

Table 251. MonoOutPin Ctl Command Response Format

Bit	Bitfield Name	RW	Reset	Description
[31:7]	Rsvd2	R	0x0	Reserved
[6]	OutEn	RW	0x0	1 = (CODEC) output path of Pin Widget is enabled
[5:0]	Rsvd1	R	0x0	Reserved

5.19.7. MonoOutPin Config

Table 252. MonoOutPin Config Command Verb Format

	Verb ID	Payload	Response
Get	F1C	00	See bitfield table
Set1	71C	See bits [7:0] of bitfield table	0000_0000h
Set2	71D	See bits [15:8] of bitfield table	0000_0000h
Set3	71E	See bits [23:16] of bitfield table	0000_0000h
Set4	71F	See bits [31:24] of bitfield table	0000_0000h

Table 253. MonoOutPin Config Command Response Format

Bit	Bitfield Name	RW	Reset	Description
[31:30]	Port	RW	0x1	External Port Connectivity of the Pin Complex. 1 = no physical connection
[29:24]	Location	RW	0x10	Physical location of the jack. 10h = Internal, N/A

Table 253. MonoOutPin Config Command Response Format

Bit	Bitfield Name	RW	Reset	Description
[23:20]	Device	RW	0x0	Default Device, indicating intended use of jack. 0 = Line Out
[19:16]	Connection	RW	0x7	Connection Type. 7 = Other Analog
[15:12]	Color	RW	0x0	Color of physical jack. 0 = Unknown
[11:8]	Misc	RW	0x1	Misc[0] = Jack Detect override.
[7:4]	Assoc	RW	0xF	Default Association for Pin Complex groups. Reserved value 0000b should not be used. Value 1111b indicates lowest priority.
[3:0]	Sequence	RW	0x0	All Widgets in an association must have unique sequence number.

5.20. CDPin Node (NID = 0x11)

5.20.1. CDPin WCap

Table 254. CDPin WCap Command Verb Format

	Verb ID	Payload	Response
Get	F00	09	See bitfield table

Table 255. CDPin WCap Command Response Format

Bit	Bitfield Name	RW	Reset	Description
[31:24]	Rsvd2	R	0x0	Reserved
[23:20]	Type	R	0x4	Widget type = Pin Complex
[19:16]	Delay	R	0x0	Number of sample delays through widget
[15:12]	Rsvd1	R	0x0	Reserved
[11]	SwapCap	R	0x0	No left/right channel swap capability
[10]	PwrCntrl	R	0x0	No support for Power State control
[9]	DigitalStrm	R	0x0	Widget supports an Analog stream

Table 255. CDPin WCap Command Response Format

Bit	Bitfield Name	RW	Reset	Description
[8]	ConnList	R	0x0	No connection list is present
[7]	UnsolCap	R	0x0	No support for Unsolicited Response
[6]	ProcWidget	R	0x0	No Processing Controls parameter
[5]	Stripe	R	0x0	No support for striping
[4]	FormatOvrd	R	0x0	N/A for pin complex
[3]	AmpParamOvrd	R	0x0	No amplifier info; use default amplifier parameters from Audio Function node instead.
[2]	OutAmpPrsnt	R	0x0	No output amp
[1]	InAmpPrsnt	R	0x0	No input amp
[0]	Stereo	R	0x1	Stereo widget

5.20.2. CDPin Cap

Table 256. CDPin Cap Command Verb Format

	Verb ID	Payload	Response
Get	F00	0C	See bitfield table

Table 257. CDPin Cap Command Response Format

Bit	Bitfield Name	RW	Reset	Description
[31:17]	Rsvd2	R	0x0	Reserved
[16]	EapdCap	R	0x0	This widget does not control EAPD pin
[15:8]	VRefCntrl	R	0x00	VRef generation not supported by this pin complex.
[7]	Rsvd1	R	0x0	Reserved
[6]	BalancedIO	R	0x0	Pin complex does not have balanced pins.
[5]	InCap	R	0x1	Pin complex is input capable.

Table 257. CDPin Cap Command Response Format

Bit	Bitfield Name	RW	Reset	Description
[4]	OutCap	R	0x0	Pin complex is not output capable.
[3]	HPhnDrvCap	R	0x0	Pin does not have a headphone amplifier.
[2]	PresDtctCap	R	0x0	Pin complex cannot perform Presence Detect.
[1]	TrigRqd	R	0x0	N/A
[0]	ImpSenseCap	R	0x0	Pin complex does not support impedance sense.

5.20.3. CDPin Ctl

Table 258. CDPin Ctl Command Verb Format

	Verb ID	Payload	Response
Get	F07	00	See bitfield table
Set1	707	See bits [7:0] of bitfield table	0000_0000h

Table 259. CDPin Ctl Command Response Format

Bit	Bitfield Name	RW	Reset	Description
[31:6]	Rsvd2	R	0x0	Reserved
[5]	InEn	RW	0x1	1 = (CODEC) input path of Pin Widget is enabled (un-muted)
[4:0]	Rsvd1	R	0x0	Reserved

5.20.4. CDPin Config

Table 260. CDPin Config Command Verb Format

	Verb ID	Payload	Response
Get	F1C	00	See bitfield table
Set1	71C	See bits [7:0] of bitfield table	0000_0000h

Table 260. CDPin Config Command Verb Format

	Verb ID	Payload	Response
Set2	71D	See bits [15:8] of bitfield table	0000_0000h
Set3	71E	See bits [23:16] of bitfield table	0000_0000h
Set4	71F	See bits [31:24] of bitfield table	0000_0000h

Table 261. CDPin Config Command Response Format

Bit	Bitfield Name	RW	Reset	Description
[31:30]	Port	RW	0x2	External Port Connectivity of the Pin Complex. 2 = fixed function device
[29:24]	Location	RW	0x10	Physical location of the jack. 10h = Internal, N/A
[23:20]	Device	RW	0x3	Default Device, indicating intended use of jack. 3 = CD
[19:16]	Connection	RW	0x3	Connection Type. 3 = ATAPI internal
[15:12]	Color	RW	0x0	Color of physical jack. 0 = Unknown
[11:8]	Misc	RW	0x1	Misc[0] = Jack Detect override.
[7:4]	Assoc	RW	0x2	Default Association for Pin Complex groups. Reserved value 0000b should not be used. Value 1111b indicates lowest priority.
[3:0]	Sequence	RW	0x2	All Widgets in an association must have unique sequence number.

5.21. MonoOutMix Node (NID = 0x12)

5.21.1. MonoOutMix WCap

Table 262. MonoOutMix WCap Command Verb Format

	Verb ID	Payload	Response
Get	F00	09	See bitfield table

Table 263. MonoOutMix WCap Command Response Format

Bit	Bitfield Name	RW	Reset	Description
[31:24]	Rsvd2	R	0x0	Reserved
[23:20]	Type	R	0x2	Widget type = Audio Mixer
[19:16]	Delay	R	0x0	Number of sample delays through widget
[15:12]	Rsvd1	R	0x0	Reserved
[11]	SwapCap	R	0x0	Swapping of left and right channels not supported
[10]	PwrCntrl	R	0x0	No support for Power State control
[9]	DigitalStrm	R	0x0	Widget supports an Analog stream
[8]	ConnList	R	0x1	Connection list is present
[7]	UnsolCap	R	0x0	No support for Unsolicited Response
[6]	ProcWidget	R	0x0	No Processing Controls parameter.
[5]	Stripe	R	0x0	No support for striping
[4]	FormatOvrd	R	0x0	No format info; use default format parameters from Audio Function node instead
[3]	AmpParamOvrd	R	0x0	No amplifier info; use default amplifier parameters from Audio Function node instead
[2]	OutAmpPrsnt	R	0x0	No output amp
[1]	InAmpPrsnt	R	0x0	No input amp
[0]	Stereo	R	0x0	Mono widget

5.21.2. MonoOutMix ConnLen

Table 264. MonoOutMix ConnLen Command Verb Format

	Verb ID	Payload	Response
Get	F00	0E	See bitfield table

Table 265. MonoOutMix ConnLen Command Response Format

Bit	Bitfield Name	RW	Reset	Description
[31:8]	Rsvd	R	0x0	Reserved.
[7]	LongForm	R	0x0	Connection list uses short-form (7-bit) NID entries.
[6:0]	N	R	0x01	Number of NID entries in connection list.

5.21.3. MonoOutMix ConnLst

Table 266. MonoOutMix ConnLst Command Verb Format

	Verb ID	Payload	Response
Get	F02	00	See bitfield table

Table 267. MonoOutMix ConnLst Command Response Format

Bit	Bitfield Name	RW	Reset	Description
[31:24]	Entry3	R	0x00	Unused list entry.
[23:16]	Entry2	R	0x00	Unused list entry.
[15:8]	Entry1	R	0x00	Unused list entry.
[7:0]	Entry0	R	0x06	DAC Mux widget.

5.22. PCBeep Node (NID = 0x13)

5.22.1. PCBeep Vol

Table 268. PCBeep Vol Command Verb Format

	Verb ID	Payload	Response
Get	BA0	00	See bitfield table
Set1	3A0	See bits [7:0] of bitfield table	0000_0000h

Table 269. PCBeep Vol Command Response Format

Bit	Bitfield Name	RW	Reset	Description
[31:8]	Rsvd2	R	0x0	Reserved
[7]	Mute	RW	0x1	1 = mute is active
[6:2]	Rsvd1	R	0x0	Reserved
[1:0]	Gain	RW	0x3	Mono (left) amplifier gain step number

5.22.2. PCBeep WCap

Table 270. PCBeep WCap Command Verb Format

	Verb ID	Payload	Response
Get	F00	09	See bitfield table

Table 271. PCBeep WCap Command Response Format

Bit	Bitfield Name	RW	Reset	Description
[31:24]	Rsvd3	R	0x0	Reserved
[23:20]	Type	R	0x7	Widget type = Beep Generator
[19:4]	Rsvd2	R	0x0	Reserved
[3]	AmpParamOvrD	R	0x1	This widget contains its own amplifier parameters.
[2]	OutAmpPrsnt	R	0x1	Output amp is present
[1]	InAmpPrsnt	R	0x0	N/A
[0]	Stereo	R	0x0	Mono widget

5.22.3. PCBeep OutAmpCap

Table 272. PCBeep OutAmpCap Command Verb Format

	Verb ID	Payload	Response
Get	F00	12	See bitfield table

Table 273. PCBeep OutAmpCap Command Response Format

Bit	Bitfield Name	RW	Reset	Description
[31]	Mute	R	0x1	Amplifier is capable of muting
[30:23]	Rsvd3	R	0x0	Reserved
[22:16]	StepSize	R	0x17	Size of each step in the gain range = 6 dB
[15]	Rsvd2	R	0x0	Reserved
[14:8]	NumSteps	R	0x03	Number of steps in the gain range = 3 (4 values, -18dB to 0dB)
[7]	Rsvd1	R	0x0	Reserved
[6:0]	Offset	R	0x03	0dB-step is programmed with this offset

5.22.4. PCBeep Gen

Table 274. PCBeep Gen Command Verb Format

	Verb ID	Payload	Response
Get	F0A	00	See bitfield table
Set1	70A	See bits [7:0] of bitfield table	0000_0000h

Table 275. PCBeep Gen Command Response Format

Bit	Bitfield Name	RW	Reset	Description
[31:8]	Rsvd	R	0x0	Reserved
[7:0]	Divider	RW	0x00	Enable internal PC-Beep generation. Divider = 00h - disables internal PC Beep generation and enables normal operation of the CODEC. Divider not 00h - generates the beep tone on all Pin Complexes that are currently configured as outputs. The HD Audio spec states that the beep tone: frequency = (48 KHz HD Audio SYNC rate) / (4*Divider), producing tones from 47 Hz to 12 KHz (logarithmic scale). Instead, this part generates tones with frequency = 48000 * (257 - Divider) / 1024, yielding a linear range from 12 KHz to 93.75 Hz in steps of 46.875 Hz. If JackSenseVSR[Rate2x], then the beep tones generated have: frequency = 48000 * (513 - Divider) / 1024, yielding a range of 24 KHz to 12093.75 Hz in steps of 46.875 Hz.

5.23. ADC0InMux Node (NID = 0x14)

5.23.1. ADC0InMux WCap

Table 276. ADC0InMux WCap Command Verb Format

	Verb ID	Payload	Response
Get	F00	09	See bitfield table

Table 277. ADC0InMux WCap Command Response Format

Bit	Bitfield Name	RW	Reset	Description
[31:24]	Rsvd2	R	0x0	Reserved
[23:20]	Type	R	0x3	Widget type = Audio Selector
[19:16]	Delay	R	0x0	Number of sample delays through widget
[15:12]	Rsvd1	R	0x0	Reserved
[11]	SwapCap	R	0x1	Left and right channels can be swapped

Table 277. ADC0InMux WCap Command Response Format

Bit	Bitfield Name	RW	Reset	Description
[10]	PwrCntrl	R	0x0	No support for Power State control
[9]	DigitalStrm	R	0x0	Widget supports an Analog stream
[8]	ConnList	R	0x1	Connection list is present
[7]	UnsolCap	R	0x0	No support for Unsolicited Response
[6]	ProcWidget	R	0x0	No Processing Controls parameter.
[5]	Stripe	R	0x0	No support for striping
[4]	FormatOvrđ	R	0x0	No format info; use default format parameters from Audio Function node instead
[3]	AmpParamOvrđ	R	0x1	This widget contains its own amplifier parameters.
[2]	OutAmpPrsnt	R	0x1	Output amp is present
[1]	InAmpPrsnt	R	0x0	No input amp
[0]	Stereo	R	0x1	Stereo widget

5.23.2. ADC0InMux ConnLen

Table 278. ADC0InMux ConnLen Command Verb Format

	Verb ID	Payload	Response
Get	F00	0E	See bitfield table

Table 279. ADC0InMux ConnLen Command Response Format

Bit	Bitfield Name	RW	Reset	Description
[31:8]	Rsvd	R	0x0	Reserved
[7]	LongForm	R	0x0	Connection list uses short-form (7-bit) NID entries.
[6:0]	N	R	0x02	Number of NID entries in connection list. 2h if Dig Mic is available, 1h if it is disabled by bond option.

5.23.3. ADC0InMux ConnSel

Table 280. ADC0InMux ConnSel Command Verb Format

	Verb ID	Payload	Response
Get	F01	00	See bitfield table
Set1	701	See bits [7:0] of bitfield table	0000_0000h

Table 281. ADC0InMux ConnSel Command Response Format

Bit	Bitfield Name	RW	Reset	Description
[31:2]	Rsvd	R	0x0	Reserved
[1:0]	Index	RW	0x0	Connection select control index.

5.23.4. ADC0InMux ConnLst

Table 282. ADC0InMux ConnLst Command Verb Format

	Verb ID	Payload	Response
Get	F02	00	See bitfield table

Table 283. ADC0InMux ConnLst Command Response Format

Bit	Bitfield Name	RW	Reset	Description
[31:24]	Entry3	R	0x00	Unused list entry
[23:16]	Entry2	R	0x00	Unused list entry
[15:8]	Entry1	R	0x15	Dig Mic pin widget (15h) if Dig Mic is available, 0h if it is disabled by bond option.
[7:0]	Entry0	R	0x09	ADC0VolMux

5.23.5. *ADC0InMux LR*

Table 284. ADC0InMux LR Command Verb Format

	Verb ID	Payload	Response
Get	F0C	00	See bitfield table
Set1	70C	See bits [7:0] of bitfield table	0000_0000h

Table 285. ADC0InMux LR Command Response Format

Bit	Bitfield Name	RW	Reset	Description
[31:3]	Rsvd2	R	0x0	Reserved
[2]	SwapEn	RW	0x0	1 = swap left and right channels of this Widget.
[1:0]	Rsvd1	R	0x0	Reserved

5.23.6. *ADC0InMux OutAmpCap*

Table 286. ADC0InMux OutAmpCap Command Verb Format

	Verb ID	Payload	Response
Get	F00	12	See bitfield table

Table 287. ADC0InMux OutAmpCap Command Response Format

Bit	Bitfield Name	RW	Reset	Description
[31]	Mute	R	0x1	Amplifier is capable of muting
[30:23]	Rsvd3	R	0x0	Reserved
[22:16]	StepSize	R	0x00	Size of each step in the gain range, N/A since there are no steps
[15]	Rsvd2	R	0x0	Reserved
[14:8]	NumSteps	R	0x00	No steps, gain is fixed at 0dB
[7]	Rsvd1	R	0x0	Reserved
[6:0]	Offset	R	0x00	0dB-step is programmed with this offset

5.23.7. ADC0InMux VolRight

Table 288. ADC0InMux VolRight Command Verb Format

	Verb ID	Payload	Response
Get	B80	00	See bitfield table
Set1	390	See bits [7:0] of bitfield table	0000_0000h

Table 289. ADC0InMux VolRight Command Response Format

Bit	Bitfield Name	RW	Reset	Description
[31:8]	Rsvd2	R	0x0	Reserved
[7]	Mute	RW	0x1	1 = mute is active
[6:0]	Rsvd1	R	0x0	Reserved

5.23.8. ADC0InMux VolLeft

Table 290. ADC0InMux VolLeft Command Verb Format

	Verb ID	Payload	Response
Get	BA0	00	See bitfield table
Set1	3A0	See bits [7:0] of bitfield table	0000_0000h

Table 291. ADC0InMux VolLeft Command Response Format

Bit	Bitfield Name	RW	Reset	Description
[31:8]	Rsvd2	R	0x0	Reserved
[7]	Mute	RW	0x1	1 = mute is active
[6:0]	Rsvd1	R	0x0	Reserved

5.24. DigMicPin Node (NID = 0x15)

5.24.1. DigMicPin WCap

Table 292. DigMicPin WCap Command Verb Format

	Verb ID	Payload	Response
Get	F00	09	See bitfield table

Table 293. DigMicPin WCap Command Response Format

Bit	Bitfield Name	RW	Reset	Description
[31:24]	Rsvd2	R	0x0	Reserved
[23:20]	Type	R	0x4	Widget type = Pin Complex
[19:16]	Delay	R	0x0	Number of sample delays through widget
[15:12]	Rsvd1	R	0x0	Reserved
[11]	SwapCap	R	0x0	No left/right channel swap capability
[10]	PwrCntrl	R	0x0	No support for Power State control
[9]	DigitalStrm	R	0x0	Widget supports an Analog stream (Since the digital microphone input is a SDM signal that needs to be processed by the digital filters, it is not a true bit for bit digital stream like I ² S or SPDIF where samples are passed through unchanged.)
[8]	ConnList	R	0x0	No connection list is present
[7]	UnsolCap	R	0x0	No support for Unsolicited Response
[6]	ProcWidget	R	0x0	No Processing Controls parameter
[5]	Stripe	R	0x0	No support for striping
[4]	FormatOvrd	R	0x0	N/A for pin complex
[3]	AmpParamOvrd	R	0x0	No amplifier info; use default amplifier parameters from Audio Function node instead.
[2]	OutAmpPrsnt	R	0x0	No output amp

Table 293. DigMicPin WCap Command Response Format

Bit	Bitfield Name	RW	Reset	Description
[1]	InAmpPrsnt	R	0x0	No input amp
[0]	Stereo	R	0x1	Stereo widget

5.24.2. DigMicPin Cap

Table 294. DigMicPin Cap Command Verb Format

	Verb ID	Payload	Response
Get	F00	0C	See bitfield table

Table 295. DigMicPin Cap Command Response Format

Bit	Bitfield Name	RW	Reset	Description
[31:17]	Rsvd2	R	0x0	Reserved
[16]	EapdCap	R	0x0	This widget does not control EAPD pin
[15:8]	VRefCntrl	R	0x00	VRef generation not supported by this pin complex.
[7]	Rsvd1	R	0x0	Reserved
[6]	BalancedIO	R	0x0	Pin complex does not have balanced pins.
[5]	InCap	R	0x1	Pin complex is input capable.
[4]	OutCap	R	0x0	Pin complex is not output capable.
[3]	HPHnDrvCap	R	0x0	Pin does not have a headphone amplifier.
[2]	PresDtctCap	R	0x0	Pin complex cannot perform Presence Detect.
[1]	TrigRqd	R	0x0	N/A
[0]	ImpSenseCap	R	0x0	Pin complex does not support impedance sense.

5.24.3. DigMicPin Ctl

Table 296. DigMicPin Ctl Command Verb Format

	Verb ID	Payload	Response
Get	F07	00	See bitfield table
Set1	707	See bits [7:0] of bitfield table	0000_0000h

Table 297. DigMicPin Ctl Command Response Format

Bit	Bitfield Name	RW	Reset	Description
[31:6]	Rsvd2	R	0x0	Reserved
[5]	InEn	RW	0x0	1 = (CODEC) input path of Pin Widget is enabled
[4:0]	Rsvd1	R	0x0	Reserved

5.24.4. DigMicPin Config

Table 298. DigMicPin Config Command Verb Format

	Verb ID	Payload	Response
Get	F1C	00	See bitfield table
Set1	71C	See bits [7:0] of bitfield table	0000_0000h
Set2	71D	See bits [15:8] of bitfield table	0000_0000h
Set3	71E	See bits [23:16] of bitfield table	0000_0000h
Set4	71F	See bits [31:24] of bitfield table	0000_0000h

Table 299. DigMicPin Config Command Response Format

Bit	Bitfield Name	RW	Reset	Description
[31:30]	Port	RW	0x1	External Port Connectivity of the Pin Complex. 1 = no physical connection
[29:24]	Location	RW	0x10	Physical location of the jack. 10h = Internal, N/A
[23:20]	Device	RW	0xA	Default Device, indicating intended use of jack. A = Mic In

Table 299. DigMicPin Config Command Response Format

Bit	Bitfield Name	RW	Reset	Description
[19:16]	Connection	RW	0x0	Connection Type. 0 = Unknown
[15:12]	Color	RW	0x0	Color of physical jack. 0 = Unknown
[11:8]	Misc	RW	0x1	Misc[0] = Jack Detect override.
[7:4]	Assoc	RW	0xF	Default Association for Pin Complex groups. Reserved value 0000b should not be used. Value 1111b indicates lowest priority.
[3:0]	Sequence	RW	0x1	All Widgets in an association must have unique sequence number.

6. ORDERING INFORMATION

6.1. STAC9202 Options and Part Numbers

The +4 V Analog voltage is supported by the +5 V version of the STAC9202..

Part Order Number	Voltage	DAC SNR	Pkg Pins
STAC9202X5TAEyy	5 V / 4 V	100dB	48 LQFP
STAC9202X3TAEyy	3.3 V	100dB	48 LQFP

NOTE: When ordering these parts the “yy” will be replaced with the CODEC revision. Add an “R” to the end of any of these part numbers for delivery on Tape and Reel. The minimum order quantity for Tape and Reel is 2,000 units for both package options.

7. PIN INFORMATION

7.1. STAC9202 Pin Diagram

Figure 3. STAC9202 Pin Diagram

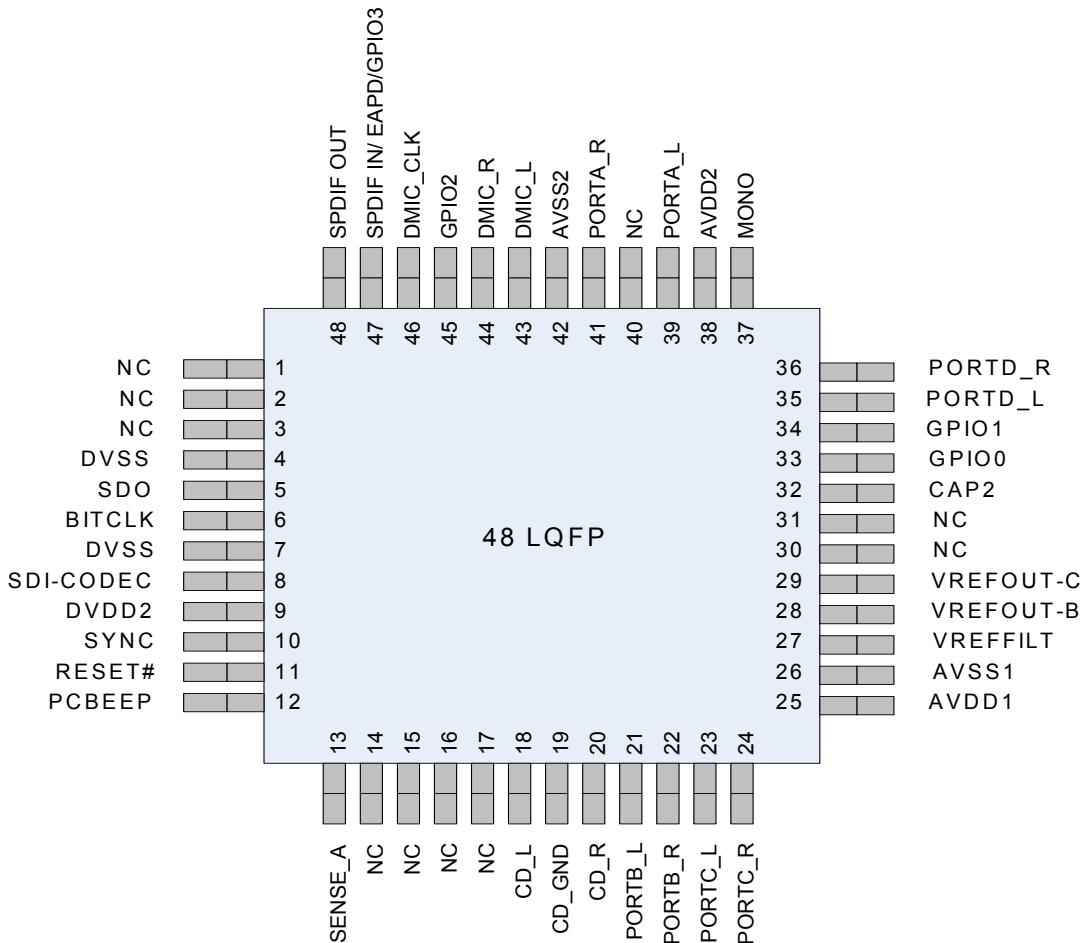

7.2. Pin Table for STAC9202

Pin Name	Pin Function	I/O	Internal Pull-up /Pull-down	Pin Location
NC	No Connect	None	None	1
NC	No Connect	None	None	2
NC	No Connect	None	None	3
DVSS	Digital Ground	I(Digital)	None	4
SDATA_OUT	HD Audio Serial Data output (inbound stream)	I/O(Digital)	None	5
BIT_CLK	HD Audio Bit Clock	I(Digital)	None	6

Pin Name	Pin Function	I/O	Internal Pull-up /Pull-down	Pin Location
DVSS	Digital Ground	I(Digital)	None	7
SDATA_IN/ CODEC	HD Audio Serial Data input for the CODEC (outbound stream)	O(Digital)	None	8
DVDD_CORE2	Digital Vdd = 3.3 V	I(Digital)	None	9
SYNC	HD Audio Frame Sync	I(Digital)	None	10
RESET#	HD Audio Reset	I(Digital)	None	11
PCBEEP	PC BEEP	I(Analog)	None	12
SENSE_A	Jack insertion detection Ports A, B, C, D	I(Analog)	None	13
NC	No Connect	None	None	14
NC	No Connect	None	None	15
NC	No Connect	None	None	16
NC	No Connect	None	None	17
CD-L	CD Audio Left Channel	I(Analog)	None	18
CD-GND	CD Audio Analog Ground	I(Analog)	None	19
CD-R	CD Audio Right Channel	I(Analog)	None	20
PORT-B_L	Input/Output of Left DAC0	I/O(Analog)	None	21
PORT-B_R	Input/Output of Right DAC0	I/O(Analog)	None	22
PORT-C_L	Input/Output of Left DAC0	I/O(Analog)	None	23
PORT-C_R	Input/Output of Right DAC0	I/O(Analog)	None	24
AVDD1	Analog Vdd = 5.0 V or 3.3 V	I(Analog)	None	25
AVSS1	Analog Ground	I(Analog)	None	26
VREF FILT	Analog Virtual Ground	O(Analog)	None	27
VREFOUT-B	Reference Voltage out drive (intended for microphone bias) for Port B	O(Analog)	None	28
VREFOUT-C	Reference Voltage out drive (intended for microphone bias) for Port C	O(Analog)	None	29
NC	No Connect	None	None	30
NC	No Connect	None	None	31
CAP2	ADC reference Cap	O(Analog)	None	32
GPIO0	General Purpose I/O tied to AVDD50K internal pull-up to AVddgnda	I/O(Digital)	Pull-up 50 K Ω or more	33
GPIO1	General Purpose I/O tied to AVDD50K internal pull-up to AVddgnda	I/O(Digital)	Pull-up 50 K Ω or more	34
PORT-D_L	Input/Output of Left DAC0	I/O(Analog)	None	35
PORT-D_R	Input/Output of Right DAC0	I/O(Analog)	None	36
MONO	Mono Out from DAC	O(Analog)	None	37
AVDD2	Analog Vdd = 5.0 V or 3.3 V	I(Analog)	None	38
PORT-A_L	Input/Output of Left DAC0	I/O(Analog)	None	39

Pin Name	Pin Function	I/O	Internal Pull-up /Pull-down	Pin Location
NC	No Connect	None	None	40
PORT-A_R	Input/Output of Right DAC0	I/O(Analog)	None	41
AVSS3	Analog Ground	I(Analog)	None	42
DMIC_L	Digital Mic Input Left Channel	I(Digital)	None	43
DMIC_R	Digital Mic Input Right Channel	I(Digital)	None	44
GPIO2	General Purpose I/O tied to AVDD50K internal pull-up to AVddgnda	I/O(Digital)	Pull-up 50 K Ω or more	45
DMIC_CLK	Digital Mic Output Clock	O(Digital)	None	46
SPDIFIN/EAPD/GPIO3	SPDIF Input, External Amplifier Power Down, General Purpose I/O	I/O(Digital)	None	47
S/SPDIF_OUT	SPDIF digital output (50K internal pull-down)	O(Digital)	50 K Ω internal pull-down	48

8. PACKAGE DRAWINGS

8.1. 48-Pin LQFP

Figure 4. 48-Pin LQFP Package Outline and Package Dimensions

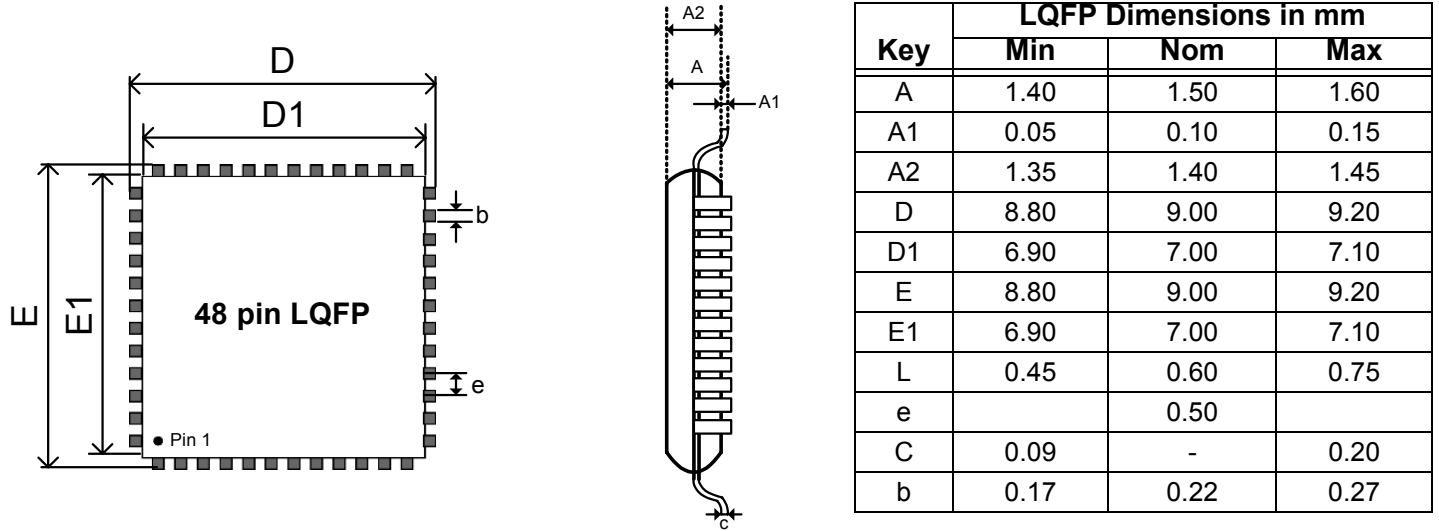

9. SOLDER REFLOW PROFILE

9.1. Standard Reflow Profile Data

Note: These devices can be hand soldered at 360 °C for 3 to 5 seconds.

FROM: IPC / JEDEC J-STD-020C "Moisture/Reflow Sensitivity Classification for Nonhermetic Solid State Surface Mount Devices" (www.jedec.org/download).

Profile Feature	Pb Free Assembly
Average Ramp-Up Rate ($T_{s_{max}} - T_p$)	3 °C / second max
Preheat Temperature Min ($T_{s_{min}}$) Temperature Max ($T_{s_{max}}$) Time ($t_{s_{min}} - t_{s_{max}}$)	150 °C 200 °C 60 - 180 seconds
Time maintained above Temperature (T_L) Time (t_L)	217 °C 60 - 150 seconds
Peak / Classification Temperature (T_p)	See "Package Classification Reflow Temperatures" on page 133.
Time within 5 °C of actual Peak Temperature (t_p)	20 - 40 seconds
Ramp-Down rate	6 °C / second max
Time 25 °C to Peak Temperature	8 minutes max
Note: All temperatures refer to topside of the package, measured on the package body surface.	

Figure 5. Solder Reflow Profile

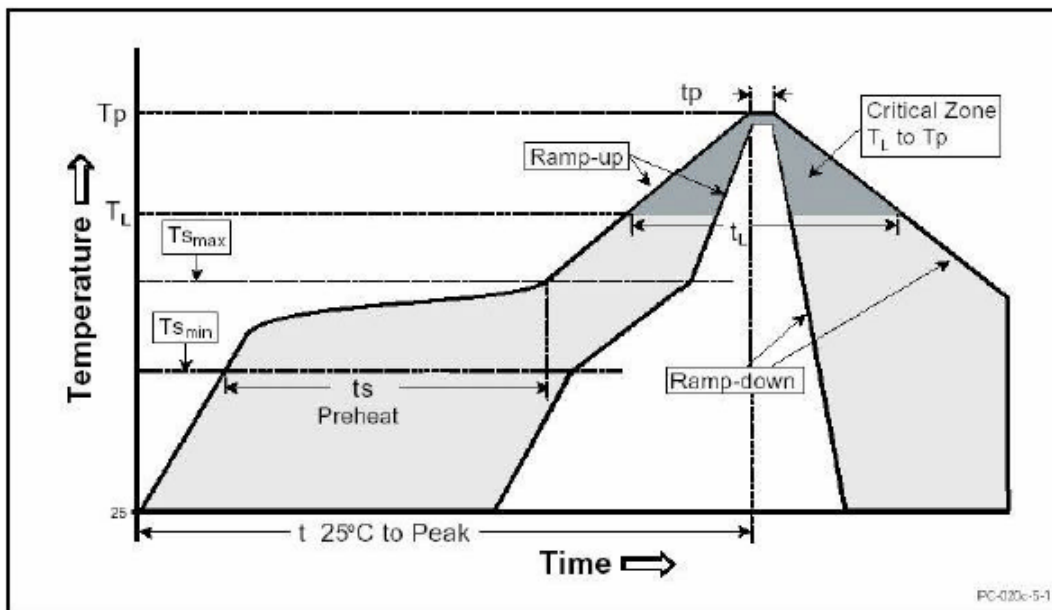

9.2. Pb Free Process - Package Classification Reflow Temperatures

Package Type	MSL	Reflow Temperature
LQFP 48-pin	3	260 °C*

10. REVISION HISTORY

Revision	Date	Description of Change
0.1	May 2005	Initial Release
0.5	August 2005	Updated 5 V Analog Performance Characteristics numbers. Updated 48 Pin Reflow Profile Table. This is a visual change only. No content was changed.
0.8	September 2005	Updated Power Consumption numbers. Added in Contact IDT note for 4 V and 3.3 V Analog AC numbers. Added updated note 4 on AC table. Added note 2 for 40dB mic boost.
1.0	November 2006	Updated logo
1.1	26 October 2006	Released in IDT format.
1.2	January 2008	Removed STAC9202D option as EOL issued.

Innovate with IDT audio for high fidelity. Contact:

www.IDT.com

For Sales

800-345-7015
408-284-8200
Fax: 408-284-2775

For Tech Support

HA.CM@idt.com

Corporate Headquarters

Integrated Device Technology, Inc.
6024 Silver Creek Valley Road
San Jose, CA 95138
United States
800 345 7015
+408 284 8200 (outside U.S.)

Europe

IDT Europe, Limited
Prime House
Barnett Wood Lane
Leatherhead, Surrey
United Kingdom KT22 7DE
+44 1372 363 339



Looking for pricing, stock, or lifecycle information?

Click below to explore more details on WIN SOURCE:

- ⊖ [View STAC9202X5TAEA1XR on WIN SOURCE](#)
- ⊖ [IDT, Integrated Device Technology Inc Information](#)

Optimize Your Supply Chain with WIN SOURCE Solutions

- ✓ Global Sourcing Solution
- ✓ Obsolete Management
- ✓ Cost Control Management
- ✓ Shortage Management
- ✓ Alternative Solution
- ✓ Excess Inventory Management