



THE DATASHEET OF STA339BWTR



2.1-channel high-efficiency digital audio system

Datasheet - production data

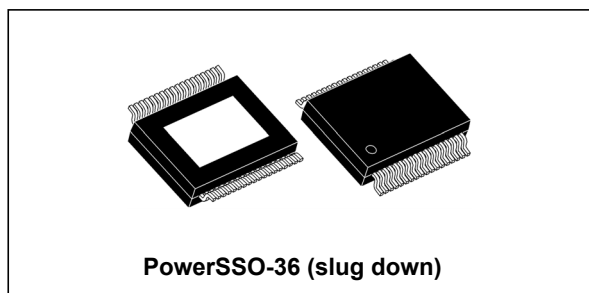

Features

- Wide voltage supply range
 - 5 V to 26 V (operating range)
 - 30 V (absolute maximum rating)
- 3 power output configurations
 - 2 channels of ternary PWM (stereo mode) (2 x 20 W into 8 Ω at 18 V)
 - 3 channels - left, right using binary and LFE using ternary PWM (2.1 mode) (2 x 9 W + 1 x 20 W into 2 x 4 Ω, 1 x 8 Ω at 18 V)
 - 2 channels of ternary PWM (2 x 20 W) + stereo lineout ternary
- 2.1 channels of 24-bit FFX[®] 100 dB SNR and dynamic range
- Selectable 32 to 192 kHz input sample rates
- I²C control with selectable device address
- Digital gain/attenuation +48 dB to -80 dB with 0.5 dB/step resolution
- Soft volume update with programmable ratio
- Individual channel and master gain/attenuation
- Two independent DRC configurable as a dual-band anti-clipper (B²DRC) or as independent limiters/compressors
- EQ-DRC for DRC based on filtered signals
- Dedicated LFE processing for bass boosting with 0.5 dB/step resolution
- Audio presets:
 - 15 preset crossover filters
 - 5 preset anti-clipping modes
 - Preset night-time listening mode
- Individual channel and master soft/hard mute
- Independent channel volume and DSP bypass
- Automatic zero-detect mute
- Automatic invalid input-detect mute
- 2-channel I²S input data interface
- Input and output channel mapping
- Up to 8 user-programmable biquads per channel with 28-bit resolution
- 3 coefficient banks for EQ presets storing with fast recall via I²C interface
- Bass/treble tones and de-emphasis control
- Selectable high-pass filter for DC blocking
- Advanced AM interference frequency switching and noise suppression modes
- Selectable high- or low-bandwidth noise-shaping topologies
- Variable max power correction for lower full-power THD
- Selectable clock input ratio
- 96 kHz internal processing sample rate, 24 to 28-bit precision
- Thermal overload and short-circuit protection embedded
- Video apps: 576 * f_S input mode supported
- Fully compatible with STA339BWS.

Table 1. Device summary

| Order code | Package | Packaging |
|------------|-----------------------|---------------|
| STA339BWTR | PowerSSO-36 slug down | Tape and reel |

Contents

| | | |
|----------|---|-----------|
| 1 | Description | 10 |
| 1.1 | Block diagram | 11 |
| 2 | Pin connections | 12 |
| 2.1 | Connection diagram | 12 |
| 2.2 | Pin description | 12 |
| 3 | Electrical specifications | 14 |
| 3.1 | Absolute maximum ratings | 14 |
| 3.2 | Thermal data | 14 |
| 3.3 | Recommended operating conditions | 15 |
| 3.4 | Electrical specifications for the digital section | 15 |
| 3.5 | Electrical specifications for the power section | 16 |
| 3.6 | Power on/off sequence | 18 |
| 3.7 | Testing | 19 |
| 3.7.1 | Functional pin definition | 19 |
| 4 | Serial audio interface | 20 |
| 4.0.1 | Timings | 20 |
| 4.0.2 | Delay serial clock enable | 20 |
| 4.0.3 | Channel input mapping | 20 |
| 5 | Processing data paths | 21 |
| 6 | I²C bus specification | 23 |
| 6.1 | Communication protocol | 23 |
| 6.1.1 | Data transition or change | 23 |
| 6.1.2 | Start condition | 23 |
| 6.1.3 | Stop condition | 23 |
| 6.1.4 | Data input | 23 |
| 6.2 | Device addressing | 23 |
| 6.3 | Write operation | 24 |
| 6.3.1 | Byte write | 24 |

| | | |
|----------|--|-----------|
| 6.3.2 | Multi-byte write | 24 |
| 6.4 | Read operation | 24 |
| 6.4.1 | Current address byte read | 24 |
| 6.4.2 | Current address multi-byte read | 24 |
| 6.4.3 | Random address byte read | 24 |
| 6.4.4 | Random address multi-byte read | 24 |
| 6.4.5 | Write mode sequence | 25 |
| 6.4.6 | Read mode sequence | 25 |
| 7 | Register description | 26 |
| 7.1 | Configuration register A (addr 0x00) | 28 |
| 7.1.1 | Master clock select | 28 |
| 7.1.2 | Interpolation ratio select | 29 |
| 7.1.3 | Thermal warning recovery bypass | 29 |
| 7.1.4 | Thermal warning adjustment bypass | 29 |
| 7.1.5 | Fault detect recovery bypass | 30 |
| 7.2 | Configuration register B (addr 0x01) | 30 |
| 7.2.1 | Serial audio input interface format | 30 |
| 7.2.2 | Serial data interface | 31 |
| 7.2.3 | Serial data first bit | 31 |
| 7.2.4 | Delay serial clock enable | 33 |
| 7.2.5 | Channel input mapping | 33 |
| 7.3 | Configuration register C (addr 0x02) | 34 |
| 7.3.1 | FFX power output mode | 34 |
| 7.3.2 | FFX compensating pulse size register | 34 |
| 7.3.3 | Overcurrent warning detect adjustment bypass | 35 |
| 7.4 | Configuration register D (addr 0x03) | 35 |
| 7.4.1 | High-pass filter bypass | 35 |
| 7.4.2 | De-emphasis | 35 |
| 7.4.3 | DSP bypass | 36 |
| 7.4.4 | Post-scale link | 36 |
| 7.4.5 | Biquad coefficient link | 36 |
| 7.4.6 | Dynamic range compression/anti-clipping bit | 36 |
| 7.4.7 | Zero-detect mute enable | 37 |
| 7.4.8 | Submix mode enable | 37 |
| 7.5 | Configuration register E (addr 0x04) | 37 |

| | | |
|--------|--|----|
| 7.5.1 | Max power correction variable | 37 |
| 7.5.2 | Max power correction | 37 |
| 7.5.3 | Noise-shaper bandwidth selection | 38 |
| 7.5.4 | AM mode enable | 38 |
| 7.5.5 | PWM speed mode | 38 |
| 7.5.6 | Distortion compensation variable enable | 38 |
| 7.5.7 | Zero-crossing volume enable | 38 |
| 7.5.8 | Soft volume update enable | 39 |
| 7.6 | Configuration register F (addr 0x05) | 39 |
| 7.6.1 | Output configuration | 39 |
| 7.6.2 | Invalid input detect mute enable | 45 |
| 7.6.3 | Binary output mode clock loss detection | 45 |
| 7.6.4 | LRCK double trigger protection | 45 |
| 7.6.5 | Auto EAPD on clock loss | 45 |
| 7.6.6 | IC power down | 45 |
| 7.6.7 | External amplifier power down | 46 |
| 7.7 | Volume control registers (addr 0x06 - 0x0A) | 46 |
| 7.7.1 | Mute/line output configuration register | 46 |
| 7.7.2 | Master volume register | 46 |
| 7.7.3 | Channel 1 volume | 46 |
| 7.7.4 | Channel 2 volume | 47 |
| 7.7.5 | Channel 3 / line output volume | 47 |
| 7.8 | Audio preset registers (addr 0x0B and 0x0C) | 48 |
| 7.8.1 | Audio preset register 1 (addr 0x0B) | 48 |
| 7.8.2 | Audio preset register 2 (addr 0x0C) | 49 |
| 7.8.3 | AM interference frequency switching | 49 |
| 7.8.4 | Bass management crossover | 49 |
| 7.9 | Channel configuration registers (addr 0x0E - 0x10) | 50 |
| 7.9.1 | Tone control bypass | 50 |
| 7.9.2 | EQ bypass | 50 |
| 7.9.3 | Volume bypass | 51 |
| 7.9.4 | Binary output enable registers | 51 |
| 7.9.5 | Limiter select | 51 |
| 7.9.6 | Output mapping | 51 |
| 7.10 | Tone control register (addr 0x11) | 52 |
| 7.10.1 | Tone control | 52 |

7.11 Dynamic control registers (addr 0x12 - 0x15) 52

7.11.1 Limiter 1 attack/release rate 52

7.11.2 Limiter 1 attack/release threshold 52

7.11.3 Limiter 2 attack/release rate 52

7.11.4 Limiter 2 attack/release threshold 53

7.11.5 Limiter 1 Extended attack threshold (addr 0x32) 56

7.11.6 Limiter 1 Extended release threshold (addr 0x33) 56

7.11.7 Limiter 2 Extended attack threshold (addr 0x34) 57

7.11.8 Limiter 2 Extended release threshold (addr 0x35) 57

7.12 User-defined coefficient control registers (addr 0x16 - 0x26) 57

7.12.1 Coefficient address register 57

7.12.2 Coefficient b1 data register bits 23:16 57

7.12.3 Coefficient b1 data register bits 15:8 57

7.12.4 Coefficient b1 data register bits 7:0 57

7.12.5 Coefficient b2 data register bits 23:16 58

7.12.6 Coefficient b2 data register bits 15:8 58

7.12.7 Coefficient b2 data register bits 7:0 58

7.12.8 Coefficient a1 data register bits 23:16 58

7.12.9 Coefficient a1 data register bits 15:8 58

7.12.10 Coefficient a1 data register bits 7:0 58

7.12.11 Coefficient a2 data register bits 23:16 58

7.12.12 Coefficient a2 data register bits 15:8 59

7.12.13 Coefficient a2 data register bits 7:0 59

7.12.14 Coefficient b0 data register bits 23:16 59

7.12.15 Coefficient b0 data register bits 15:8 59

7.12.16 Coefficient b0 data register bits 7:0 59

7.12.17 Coefficient write/read control register 59

7.12.18 User-defined EQ 62

7.12.19 Prescale 62

7.12.20 Postscale 62

7.12.21 Overcurrent postscale 63

7.13 Variable max power correction registers (addr 0x27 - 0x28) 64

7.14 Variable distortion compensation registers (addr 0x29 - 0x2A) 64

7.15 Fault detect recovery constant registers (addr 0x2B - 0x2C) 65

7.16 Device status register (addr 0x2D) 65

7.17 EQ coefficients and DRC configuration register (addr 0x31) 66

| | | |
|-----------|---|-----------|
| 7.18 | Extended configuration register (addr 0x36) | 67 |
| 7.18.1 | Dual-band DRC | 67 |
| 7.18.2 | EQ DRC mode | 68 |
| 7.18.3 | Extended post scale range | 69 |
| 7.18.4 | Extended attack rate | 69 |
| 7.18.5 | Extended BIQUAD selector | 70 |
| 7.19 | EQ soft volume configuration registers (addr 0x37 - 0x38) | 70 |
| 7.20 | DRC RMS filter coefficients (addr 0x39 - 0x3E) | 71 |
| 8 | Application | 72 |
| 8.1 | Application scheme for power supplies | 72 |
| 8.2 | PLL filter | 72 |
| 8.3 | Typical output configuration | 73 |
| 9 | Package thermal characteristics | 74 |
| 10 | Package mechanical data | 75 |
| 11 | Revision history | 77 |

List of figures

| | | |
|------------|--|----|
| Figure 1. | Block diagram | 11 |
| Figure 2. | Pin connection PowerSSO-36 (top view) | 12 |
| Figure 3. | Power-on sequence | 18 |
| Figure 4. | Power-off sequence for pop-free turn-off | 18 |
| Figure 5. | Test circuit 1 | 19 |
| Figure 6. | Test circuit 2 | 19 |
| Figure 7. | Timing diagram for SAI interface | 20 |
| Figure 8. | Left and right processing part 1 | 21 |
| Figure 9. | Processing part 2 | 22 |
| Figure 10. | Write mode sequence | 25 |
| Figure 11. | Read mode sequence | 25 |
| Figure 12. | OCFG = 00 (default value) | 40 |
| Figure 13. | OCFG = 01 | 40 |
| Figure 14. | OCFG = 10 | 40 |
| Figure 15. | OCFG = 11 | 41 |
| Figure 16. | Output mapping scheme | 41 |
| Figure 17. | 2.0 channels (OCFG = 00) PWM slots | 42 |
| Figure 18. | 2.1 channels (OCFG = 01) PWM slots | 43 |
| Figure 19. | 2.1 channels (OCFG = 10) PWM slots | 44 |
| Figure 20. | Basic limiter and volume flow diagram | 54 |
| Figure 21. | B ² DRC scheme | 67 |
| Figure 22. | EQDRC scheme | 69 |
| Figure 23. | Application diagram | 72 |
| Figure 24. | Output configuration for stereo BTL mode | 73 |
| Figure 25. | Double-layer PCB with 2 copper ground areas and 16 via holes | 74 |
| Figure 26. | PowerSSO-36 power derating curve | 74 |
| Figure 27. | PowerSSO-36 EPD outline drawing | 75 |

List of tables

| | | |
|-----------|--|----|
| Table 1. | Device summary | 1 |
| Table 2. | Pin description | 12 |
| Table 3. | Absolute maximum ratings | 14 |
| Table 4. | Thermal data | 14 |
| Table 5. | Recommended operating condition | 15 |
| Table 6. | Electrical specifications - digital section | 15 |
| Table 7. | Electrical specifications - power section | 16 |
| Table 8. | Functional pin definition | 19 |
| Table 9. | Timing parameters for slave mode | 20 |
| Table 10. | Register summary | 26 |
| Table 11. | Master clock select | 28 |
| Table 12. | Input sampling rates | 28 |
| Table 13. | Internal interpolation ratio | 29 |
| Table 14. | IR bit settings as a function of input sample rate | 29 |
| Table 15. | Thermal warning recovery bypass | 29 |
| Table 16. | Thermal warning adjustment bypass | 29 |
| Table 17. | Fault detect recovery bypass | 30 |
| Table 18. | Serial audio input interface | 30 |
| Table 19. | Serial data first bit | 31 |
| Table 20. | Supported serial audio input formats for MSB-first (SAIFB = 0) | 31 |
| Table 21. | Supported serial audio input formats for LSB-first (SAIFB = 1) | 32 |
| Table 22. | Delay serial clock enable | 33 |
| Table 23. | Channel input mapping | 33 |
| Table 24. | FFX power output mode | 34 |
| Table 25. | Output modes | 34 |
| Table 26. | FFX compensating pulse size bits | 34 |
| Table 27. | Compensating pulse size | 34 |
| Table 28. | Overcurrent warning bypass | 35 |
| Table 29. | High-pass filter bypass | 35 |
| Table 30. | De-emphasis | 35 |
| Table 31. | DSP bypass | 36 |
| Table 32. | Post-scale link | 36 |
| Table 33. | Biquad coefficient link | 36 |
| Table 34. | Dynamic range compression/anti-clipping bit | 36 |
| Table 35. | Zero-detect mute enable | 37 |
| Table 36. | Submix mode enable | 37 |
| Table 37. | Max power correction variable | 37 |
| Table 38. | Max power correction | 37 |
| Table 39. | Noise-shaper bandwidth selection | 38 |
| Table 40. | AM mode enable | 38 |
| Table 41. | PWM speed mode | 38 |
| Table 42. | Distortion compensation variable enable | 38 |
| Table 43. | Zero-crossing volume enable | 38 |
| Table 44. | Soft volume update enable | 39 |
| Table 45. | Output configuration | 39 |
| Table 46. | Output configuration engine selection | 39 |
| Table 47. | Invalid input detect mute enable | 45 |
| Table 48. | Binary output mode clock loss detection | 45 |

| | | |
|-----------|--|----|
| Table 49. | LRCK double trigger protection | 45 |
| Table 50. | Auto EAPD on clock loss | 45 |
| Table 51. | IC power down | 45 |
| Table 52. | External amplifier power down | 46 |
| Table 53. | Line output configuration | 46 |
| Table 54. | Master volume offset as a function of MV[7:0] | 47 |
| Table 55. | Channel volume as a function of CxV[7:0] | 48 |
| Table 56. | Audio preset gain compression/limiters selection for AMGC[3:2] = 00 | 48 |
| Table 57. | AM interference frequency switching bits | 49 |
| Table 58. | Audio preset AM switching frequency selection | 49 |
| Table 59. | Bass management crossover | 49 |
| Table 60. | Bass management crossover frequency | 49 |
| Table 61. | Tone control bypass | 50 |
| Table 62. | EQ bypass | 51 |
| Table 63. | Binary output enable registers | 51 |
| Table 64. | Channel limiter mapping as a function of CxLS bits | 51 |
| Table 65. | Channel output mapping as a function of CxOM bits | 51 |
| Table 66. | Tone control boost/cut as a function of BTC and TTC bits | 52 |
| Table 67. | Limiter attack rate as a function of LxA bits | 54 |
| Table 68. | Limiter release rate as a function of LxR bits | 54 |
| Table 69. | Limiter attack threshold as a function of LxAT bits (AC mode) | 55 |
| Table 70. | Limiter release threshold as a function of LxRT bits (AC mode) | 55 |
| Table 71. | Limiter attack threshold as a function of LxAT bits (DRC mode) | 56 |
| Table 72. | Limiter release threshold as a as a function of LxRT bits (DRC mode) | 56 |
| Table 73. | RAM block for biquads, mixing, scaling and bass management | 63 |
| Table 74. | Status register bits | 65 |
| Table 75. | EQ RAM select | 66 |
| Table 76. | Anti-clipping and DRC preset | 66 |
| Table 77. | Anti-clipping selection for AMGC[3:2] = 01 | 66 |
| Table 78. | Post scale setup | 69 |
| Table 79. | Extended attack rate setup for limiter 1 | 69 |
| Table 80. | Extended attack rate setup for limiter 2 | 69 |
| Table 81. | De-emphasis filter setup | 70 |
| Table 82. | Bass filter setup | 70 |
| Table 83. | Treble filter setup | 70 |
| Table 84. | Soft volume (increasing) setup | 71 |
| Table 85. | Soft volume (decreasing) setup | 71 |
| Table 86. | PowerSSO-36 EPD dimensions | 75 |
| Table 87. | Document revision history | 77 |

1 Description

The STA339BW is an integrated solution of digital audio processing, digital amplifier control, and FFX-power output stage, thereby creating a high-power single-chip FFX[®] solution comprising high-quality, high-efficiency, all digital amplification.

STA339BW is based on FFX (fully flexible amplification) processor, an STMicroelectronics proprietary technology. FFX is the evolution and the enlargement of the ST ternary technology: the new processor can be configured to work in ternary, binary, binary differential and phase shift PWM modulation schemes.

STA339BW contains the ternary, binary and binary differential implementations, a subset of the full capability of the FFX processor.

The STA339BW is part of the Sound Terminal[®] family that provides full digital audio streaming to the speaker, offering cost effectiveness, low power dissipation and sound enrichment.

The STA339BW power section consists of four independent half bridges. These can be configured via digital control to operate in different modes. 2.1 channels can be provided by two half bridges and a single full bridge, providing up to 2 x 9 W + 1 x 20 W of power output. Two channels can be provided by two full bridges, providing up to 2 x 20 W of power. The IC can also be configured as 2.1 channels with 2 x 20 W provided by the device and external power for FFX power drive.

Also provided in the STA339BW are a full assortment of digital processing features. This includes up to 8 programmable 28-bit biquads (EQ) per channel and bass/treble tone control. Available presets enable a time-to-market advantage by substantially reducing the amount of software development needed for certain functions. This includes audio preset volume loudness, preset volume curves and preset EQ settings. There are also new advanced AM radio interference reduction modes. Dual-band DRC dynamically equalizes the system to provide speaker linear frequency response regardless of the output power level. This feature independently processes the two bands, controlling dynamically the output power level in each band and so providing better sound quality.

The serial audio data input interface accepts all possible formats, including the popular I²S format. Three channels of FFX processing are provided. This high-quality conversion from PCM audio to FFX PWM switching waveform provides over 100 dB SNR and dynamic range.

1.1 Block diagram

Figure 1. Block diagram

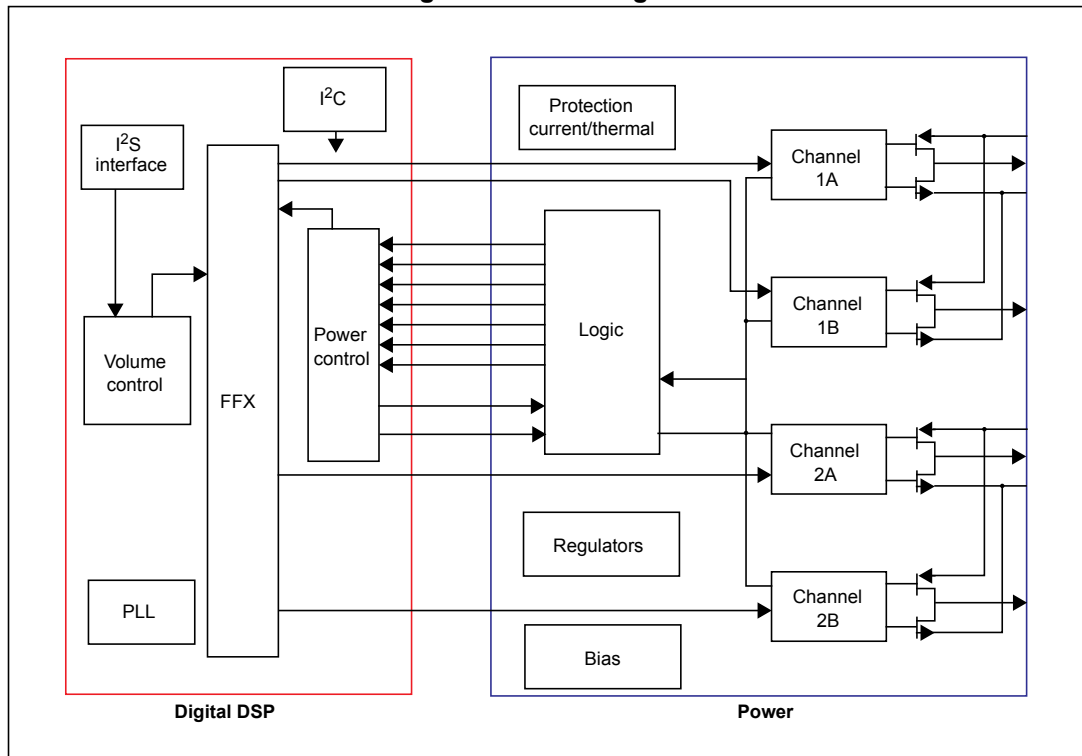

2 Pin connections

2.1 Connection diagram

Figure 2. Pin connection PowerSSO-36 (top view)

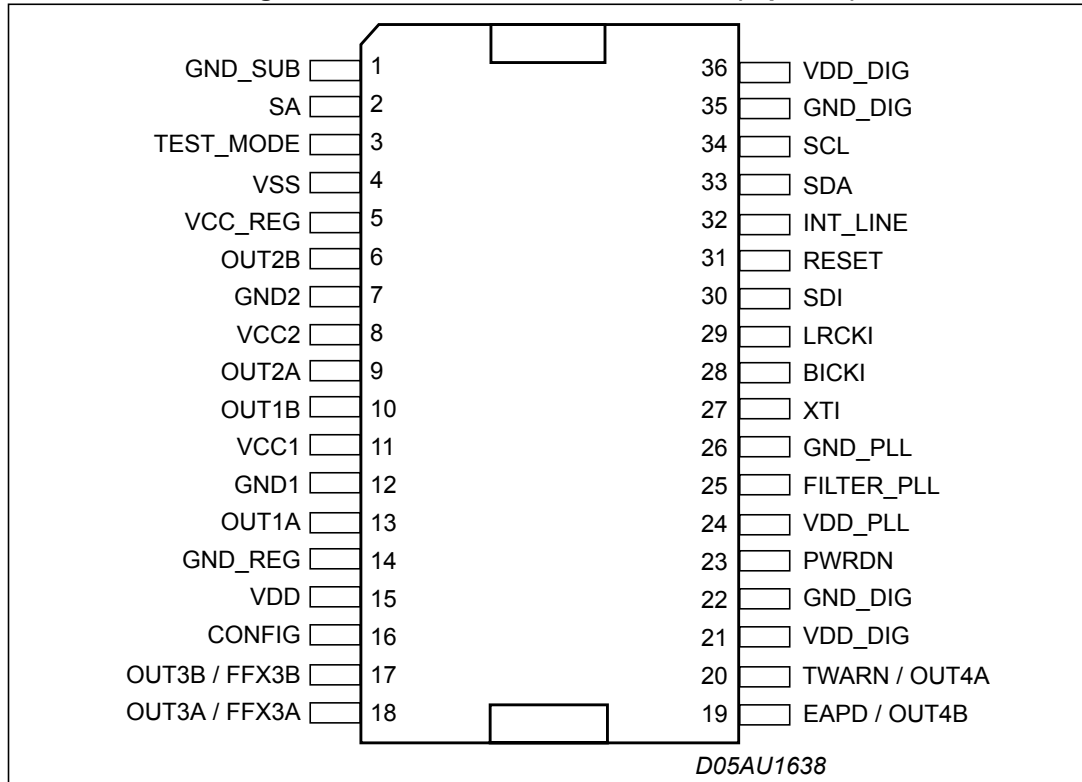

2.2 Pin description

Table 2. Pin description

| Pin | Type | Name | Description |
|-----|-------|-----------|--|
| 1 | GND | GND_SUB | Substrate ground |
| 2 | I | SA | I ² C select address (pull-down) |
| 3 | I | TEST_MODE | This pin must be connected to ground (pull-down) |
| 4 | I/O | VSS | Internal reference at V _{CC} - 3.3 V |
| 5 | I/O | VCC_REG | Internal V _{CC} reference |
| 6 | O | OUT2B | Output half bridge 2B |
| 7 | GND | GND2 | Power negative supply |
| 8 | Power | VCC2 | Power positive supply |
| 9 | O | OUT2A | Output half bridge 2A |
| 10 | O | OUT1B | Output half bridge 1B |

Table 2. Pin description (continued)

| Pin | Type | Name | Description |
|-----|-------|---------------|--|
| 11 | Power | VCC1 | Power positive supply |
| 12 | GND | GND1 | Power negative supply |
| 13 | O | OUT1A | Output half bridge 1A |
| 14 | GND | GND_REG | Internal ground reference |
| 15 | Power | VDD | Internal 3.3 V reference voltage |
| 16 | I | CONFIG | Paralleled mode command |
| 17 | O | OUT3B / FFX3B | PWM out Ch3B / external bridge driver |
| 18 | O | OUT3A / FFX3A | PWM out Ch3A / external bridge driver |
| 19 | O | EAPD / OUT4B | Power down for external bridge / PWM out Ch4B |
| 20 | I/O | TWARN / OUT4A | Thermal warning from external bridge (pull-up when input) / PWM out Ch4A |
| 21 | Power | VDD_DIG | Digital supply voltage |
| 22 | GND | GND_DIG | Digital ground |
| 23 | I | PWRDN | Power down (pull-up) |
| 24 | Power | VDD_PLL | Positive supply for PLL |
| 25 | I | FILTER_PLL | Connection to PLL filter |
| 26 | GND | GND_PLL | Negative supply for PLL |
| 27 | I | XTI | PLL input clock |
| 28 | I | BICKI | I ² S serial clock |
| 29 | I | LRCKI | I ² S left/right clock |
| 30 | I | SDI | I ² S serial data channels 1 and 2 |
| 31 | I | RESET | Reset (pull-up) |
| 32 | O | INT_LINE | Fault interrupt |
| 33 | I/O | SDA | I ² C serial data |
| 34 | I | SCL | I ² C serial clock |
| 35 | GND | GND_DIG | Digital ground |
| 36 | Power | VDD_DIG | Digital supply voltage |

3 Electrical specifications

3.1 Absolute maximum ratings

Table 3. Absolute maximum ratings

| Symbol | Parameter | Min | Typ | Max | Unit |
|------------------|-------------------------------------|------|-----|-----|------|
| V _{CC} | Power supply voltage (VCCxA, VCCxB) | -0.3 | - | 30 | V |
| VDD_DIG | Digital supply voltage | -0.3 | - | 4 | V |
| VDD_PLL | PLL supply voltage | -0.3 | - | 4 | V |
| T _{op} | Operating junction temperature | -20 | - | 150 | °C |
| T _{stg} | Storage temperature | -40 | - | 150 | °C |

Warning: Stresses beyond those listed in [Table 3](#) above may cause permanent damage to the device. These are stress ratings only, and functional operation of the device at these or any other conditions beyond those indicated under “Recommended operating conditions” are not implied. Exposure to absolute-maximum-rated conditions for extended periods may affect device reliability. In the real application, power supplies with nominal values rated within the recommended operating conditions, may experience some rising beyond the maximum operating conditions for a short time when no or very low current is sunked (amplifier in mute state). In this case the reliability of the device is guaranteed, provided that the absolute maximum ratings are not exceeded.

3.2 Thermal data

Table 4. Thermal data

| Symbol | Parameter | Min | Typ | Max | Unit |
|------------------------|--|-----|-----|-----|------|
| R _{th j-case} | Thermal resistance junction-case (thermal pad) | - | - | 1.5 | °C/W |
| R _{th j-amb} | Thermal resistance junction-ambient ⁽¹⁾ | - | - | - | °C/W |
| T _{th-sdj} | Thermal shut-down junction temperature | - | 150 | - | °C |
| T _{th-w} | Thermal warning temperature | - | 130 | - | °C |
| T _{th-sdh} | Thermal shut-down hysteresis | - | 20 | - | °C |

1. See [Section 9: Package thermal characteristics on page 74](#) for details.

3.3 Recommended operating conditions

Table 5. Recommended operating condition

| Symbol | Parameter | Min | Typ | Max | Unit |
|------------------|-------------------------------------|-----|-----|-----|------|
| V _{CC} | Power supply voltage (VCCxA, VCCxB) | 5 | - | 26 | V |
| VDD_DIG | Digital supply voltage | 2.7 | 3.3 | 3.6 | V |
| VDD_PLL | PLL supply voltage | 2.7 | 3.3 | 3.6 | V |
| T _{amb} | Ambient temperature | -20 | - | 70 | °C |

3.4 Electrical specifications for the digital section

Table 6. Electrical specifications - digital section

| Symbol | Parameter | Conditions | Min | Typ | Max | Unit |
|-----------------|--|----------------------------------|---------------|-----|---------------|------|
| I _{il} | Low-level input current without pull-up/down device | V _i = 0 V | -10 | 1 | 10 | μA |
| I _{ih} | High-level input current without pull-up/down device | V _i = VDD_DIG = 3.6 V | -10 | 1 | 10 | μA |
| V _{il} | Low-level input voltage | - | - | - | 0.2 * VDD_DIG | V |
| V _{ih} | High-level input voltage | - | 0.8 * VDD_DIG | - | - | V |
| V _{ol} | Low-level output voltage | I _{ol} = 2 mA | - | - | 0.4 * VDD_DIG | V |
| V _{oh} | High-level output voltage | I _{oh} = 2 mA | 0.8 * VDD_DIG | - | - | V |
| I _{pu} | Pull-up/down current | - | 25 | 66 | 125 | μA |
| R _{pu} | Equivalent pull-up/down resistance | - | - | 50 | - | kΩ |

3.5 Electrical specifications for the power section

The specifications given in this section are valid for the operating conditions: $V_{CC} = 18\text{ V}$, $f = 1\text{ kHz}$, $f_{sw} = 384\text{ kHz}$, $T_{amb} = 25^\circ\text{ C}$ and $R_L = 8\ \Omega$, unless otherwise specified.

Table 7. Electrical specifications - power section

| Symbol | Parameter | Conditions | Min | Typ | Max | Unit |
|-------------------|---|--|-----|--------------------|-----|---------------|
| Po | Output power BTL | THD = 1% | - | 16 | - | W |
| | | THD = 10% | - | 20 | - | |
| | Output power SE | THD = 1% | - | 4 | - | W |
| | | THD = 10% | - | 5 | - | |
| R _{dsON} | Power Pchannel/Nchannel MOSFET (total bridge) | $I_d = 1.5\text{ A}$ | - | 180 | 250 | m Ω |
| gP | Power Pchannel RdsON matching | $I_d = 1.5\text{ A}$ | 95 | - | - | % |
| gN | Power Nchannel RdsON matching | $I_d = 1.5\text{ A}$ | 95 | - | - | % |
| I _{dss} | Power Pchannel/Nchannel leakage | $V_{CC} = 20\text{ V}$ | - | - | 10 | μA |
| I _{LDT} | Low current dead time (static) | Resistive load ⁽¹⁾ | - | 8 | 15 | ns |
| I _{HDT} | High current dead time (dynamic) | $I_{load} = 1.5\text{ A}^{(1)}$ | - | 15 | 30 | ns |
| t _r | Rise time | Resistive load ⁽¹⁾ | - | 10 | 18 | ns |
| t _f | Fall time | Resistive load ⁽¹⁾ | - | 10 | 18 | ns |
| V _{CC} | Supply voltage operating voltage | - | 5 | - | 26 | V |
| I _{vcc} | Supply current from V _{CC} in power down | PWRDN = 0 | - | 0.1 | 1 | mA |
| | Supply current from V _{CC} in operation | PCM input signal = -60 dBfs, Switching frequency = 384 kHz, No LC filters | - | 52 | 60 | |
| I _{vdd} | Supply current FFX processing (reference only) | Internal clock = 49.152 MHz | - | 55 | 70 | mA |
| I _{lim} | Overcurrent limit | ⁽²⁾ | 3.0 | 3.8 ⁽³⁾ | - | A |
| I _{sc} | Short-circuit protection | Hi-Z output | 3.8 | 4.8 | - | A |
| UVL | Undervoltage protection | - | - | 3.5 | 4.3 | V |
| t _{min} | Output minimum pulse width | No load | 20 | 30 | 60 | ns |
| DR | Dynamic range | - | - | 100 | - | dB |
| SNR | Signal-to-noise ratio, ternary mode | A-weighted | - | 100 | - | dB |
| | Signal-to-noise ratio binary mode | - | - | 90 | - | |
| PSSR | Power supply rejection ratio | FFX stereo mode, <5 kHz $V_{RIPPLE} = 1\text{ V RMS}$ Audio input = dither only | - | 80 | - | dB |

Table 7. Electrical specifications - power section (continued)

| Symbol | Parameter | Conditions | Min | Typ | Max | Unit |
|-------------------|-----------------------------------|---|-----|-----|-----|------|
| THD+N | Total harmonic distortion + noise | FFX stereo mode, Po = 1 W f = 1 kHz | - | 0.2 | - | % |
| X _{TALK} | Crosstalk | FFX stereo mode, <5 kHz One channel driven at 1 W Other channel measured | - | 80 | - | dB |
| η | Peak efficiency, FFX mode | Po = 2 x 20 W into 8 Ω | - | 90 | - | % |
| | Peak efficiency, binary modes | Po = 2 x 9 W into 4 Ω + 1 x 20 W into 8 Ω | - | 87 | - | |

1. Refer to [Figure 5: Test circuit 1](#).
2. Limit current if the register (OCRB par 6.1.3.3) overcurrent warning detect adjustment bypass is enabled. When disabled, refer to I_{sc}.
3. I_{lim} typical value is 0.8*I_{sc}.

3.6 Power on/off sequence

Figure 3. Power-on sequence

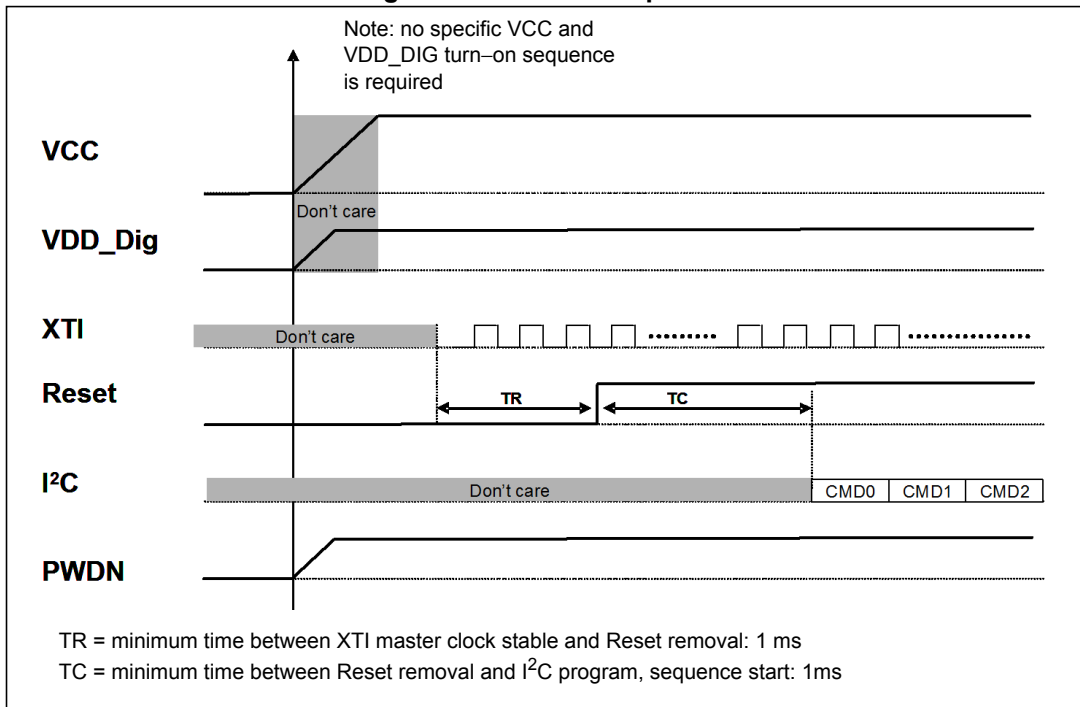

Note: The definition of a stable clock is when $f_{max} - f_{min} < 1$ MHz.

Section 7.2.3 on page 31 gives information on setting up the I²S interface.

Figure 4. Power-off sequence for pop-free turn-off

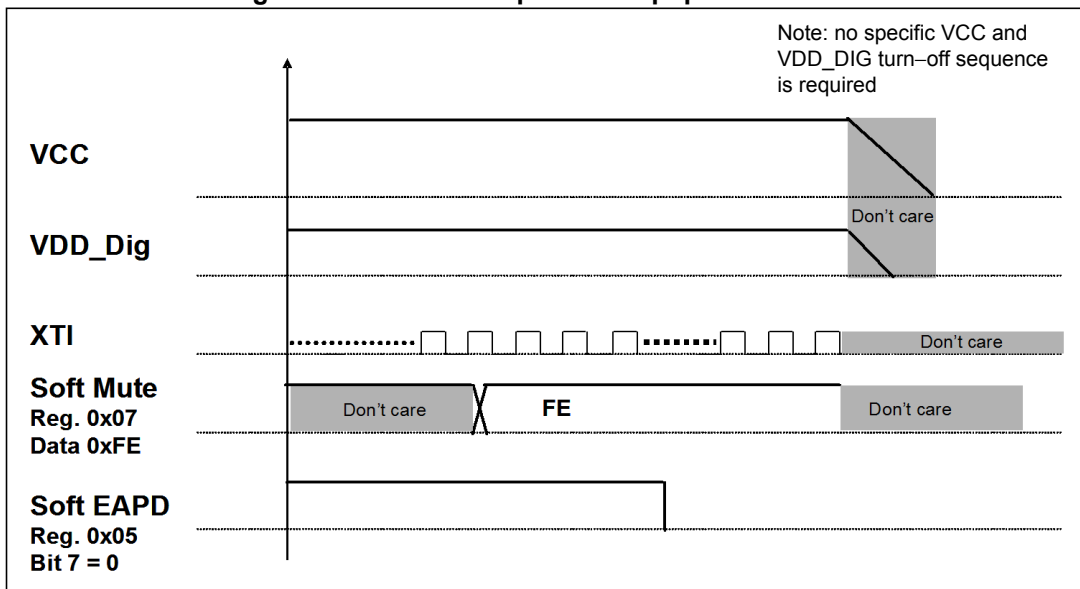

3.7 Testing

3.7.1 Functional pin definition

Table 8. Functional pin definition

| Pin name | Number | Logic value | IC status |
|----------|--------|-------------|---|
| PWRDN | 23 | 0 | Low consumption |
| | | 1 | Normal operation |
| TWARN | 20 | 0 | A temperature warning is indicated by the external power stage |
| | | 1 | Normal operation |
| EAPD | 19 | 0 | Low consumption for power stage All internal regulators are switched off |
| | | 1 | Normal operation |

Figure 5. Test circuit 1

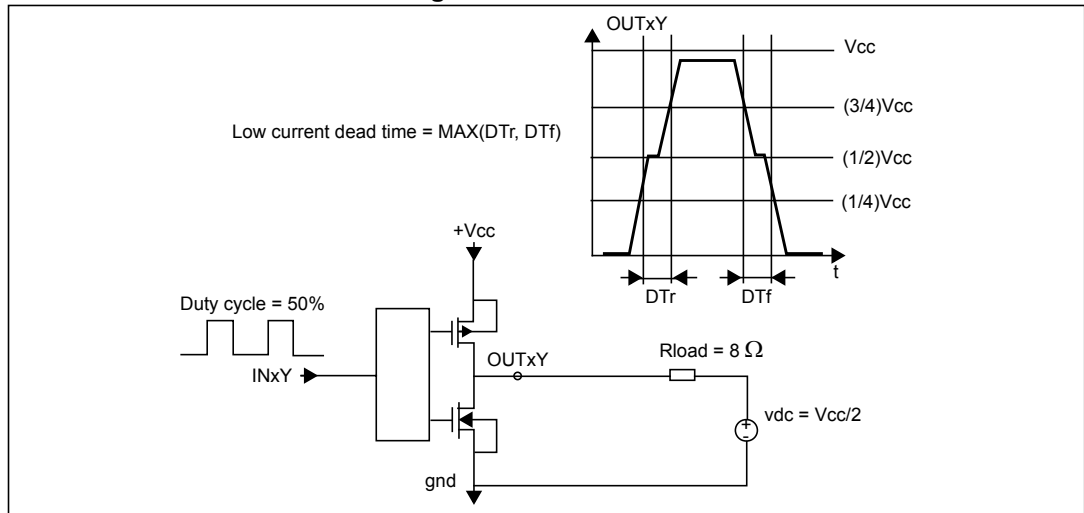
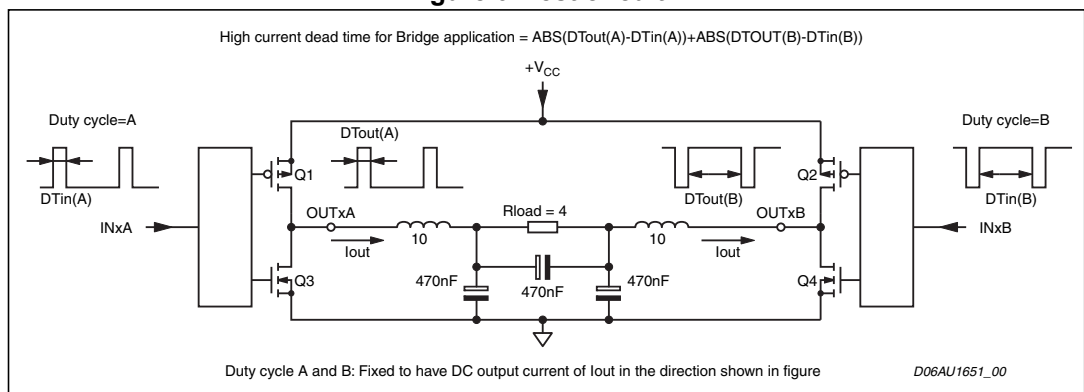

Figure 6. Test circuit 2



4 Serial audio interface

The STA339BW audio serial input interface was designed to interface with standard digital audio components and to accept a number of serial data formats. The STA339BW always acts as the slave when receiving audio input from standard digital audio components. Serial data for two channels is provided using three inputs: left/right clock LRCKI, serial clock BICKI, and serial data SDI12.

The SAI bit and the SAIFB bit are used to specify the serial data format. The default serial data format is I²S, MSB-first.

4.0.1 Timings

In the STA339BW the BICKI and LRCKI pins are configured as inputs and they must be supplied by the external peripheral.

Figure 7. Timing diagram for SAI interface

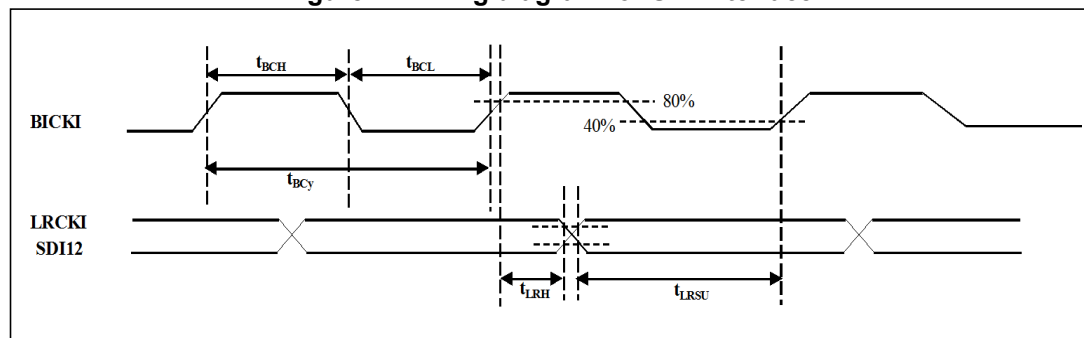

Table 9. Timing parameters for slave mode

| Symbol | Parameter | Min | Typ | Max | Unit |
|-------------------|---|-----|-----|-----|------|
| t _{BCy} | BICK cycle time | 80 | - | - | ns |
| t _{BCH} | BICK pulse width high | 40 | - | - | ns |
| t _{BCL} | BICK pulse width low | 40 | - | - | ns |
| t _{LRSU} | LRCKI setup time to BICKI strobing edge | 40 | - | - | ns |
| t _{LRH} | LRCKI hold time to BICKI strobing edge | 40 | - | - | ns |
| t _{LRJT} | LRCKI Jitter Tolerance | | | 40 | ns |

4.0.2 Delay serial clock enable

To tolerate anomalies in some I²S master devices, a PLL clock cycle delay can be added to the BICKI signal before the SAI interface.

4.0.3 Channel input mapping

Each channel received via I²S can be mapped to any internal processing channel via the channel input mapping registers. This allows for flexibility in processing. The default settings of these registers map each I²S input channel to its corresponding processing channel.

5 Processing data paths

The whole processing chain is composed of two consecutive sections. In the first one dual-channel processing is implemented, as described below. Then each channel is fed into the post-mixing block where there is a choice of processing, either the dual-band DRC is disabled or it is enabled. When B²DRC is disabled a third channel, typically used in 2.1 output configuration and with cross-over filters enabled, is used. When B²DRC is enabled the 2.0 output configuration with cross-over filters for defining the cutoff frequency of the two bands is used.

The first section, *Figure 8*, begins with a 2x oversampling FIR filter allowing a 2 * fs audio processing. Then a selectable high-pass filter removes the DC level (enabled if HPB = 0).

The channel 1 and 2 processing chain can include up to 8 filters, depending on the selected configuration (bits BQL, BQ5, BQ6, BQ7 and XO[3:0]).

By default, four independent filters per channel are enabled, plus the preconfigured de-emphasis, bass and treble controls (BQL = 0, BQ5 = 0, BQ6 = 0, BQ7 = 0).

If the coefficient sets are linked (BQL = 1) then it is possible to use the de-emphasis, bass and treble filter in a user defined configuration (provided the relevant BQx bits are set to 1). In other words both channels use the same processing coefficients and can have up to 7 filters each. Note that if BQL = 0 the BQx bits are ignored and the 5th, 6th and 7th filters are configured as de-emphasis, bass and treble controls, respectively.

Moreover the common 8th filter, from the subsequent processing section, can be available on both channels (provided the pre-defined cross-over frequencies are not used, XO[3:0] = 0, and the dual-band DRC is not used).

In the second section, mixing and crossover filters are available. If B²DRC is not enabled (lower schematic in *Figure 9*) they are fully user-programmable and allow a third channel (2.1 outputs) to be generated. Alternatively, in B²DRC mode (upper schematic in *Figure 9*), those blocks will be used to split the sub-band and define the cutoff frequencies of the two bands. A prescaler and a final post scaler allow full control over the signal dynamics before and after, respectively, the filtering stages. A mixer function is also available.

Figure 8. Left and right processing part 1

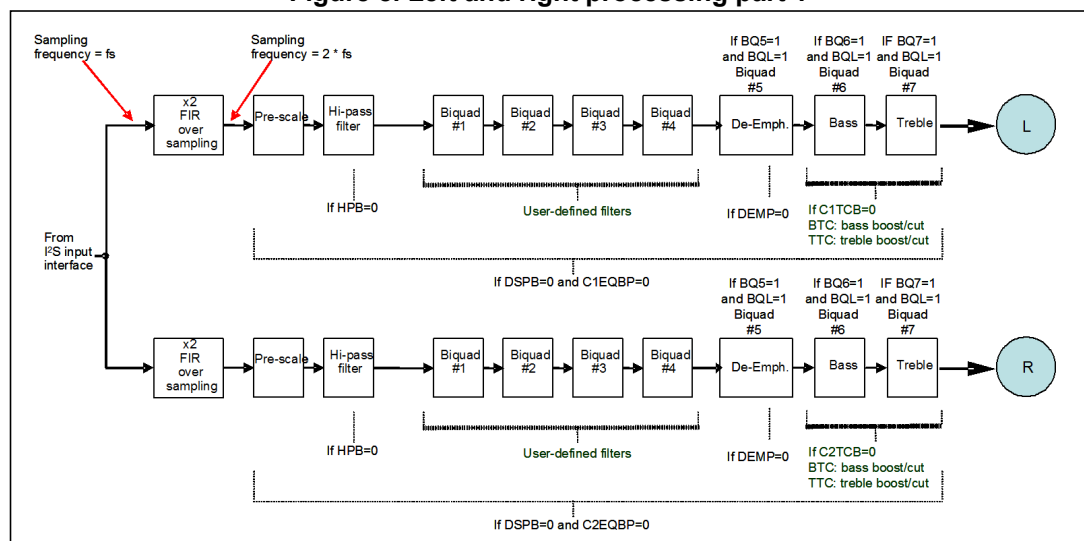
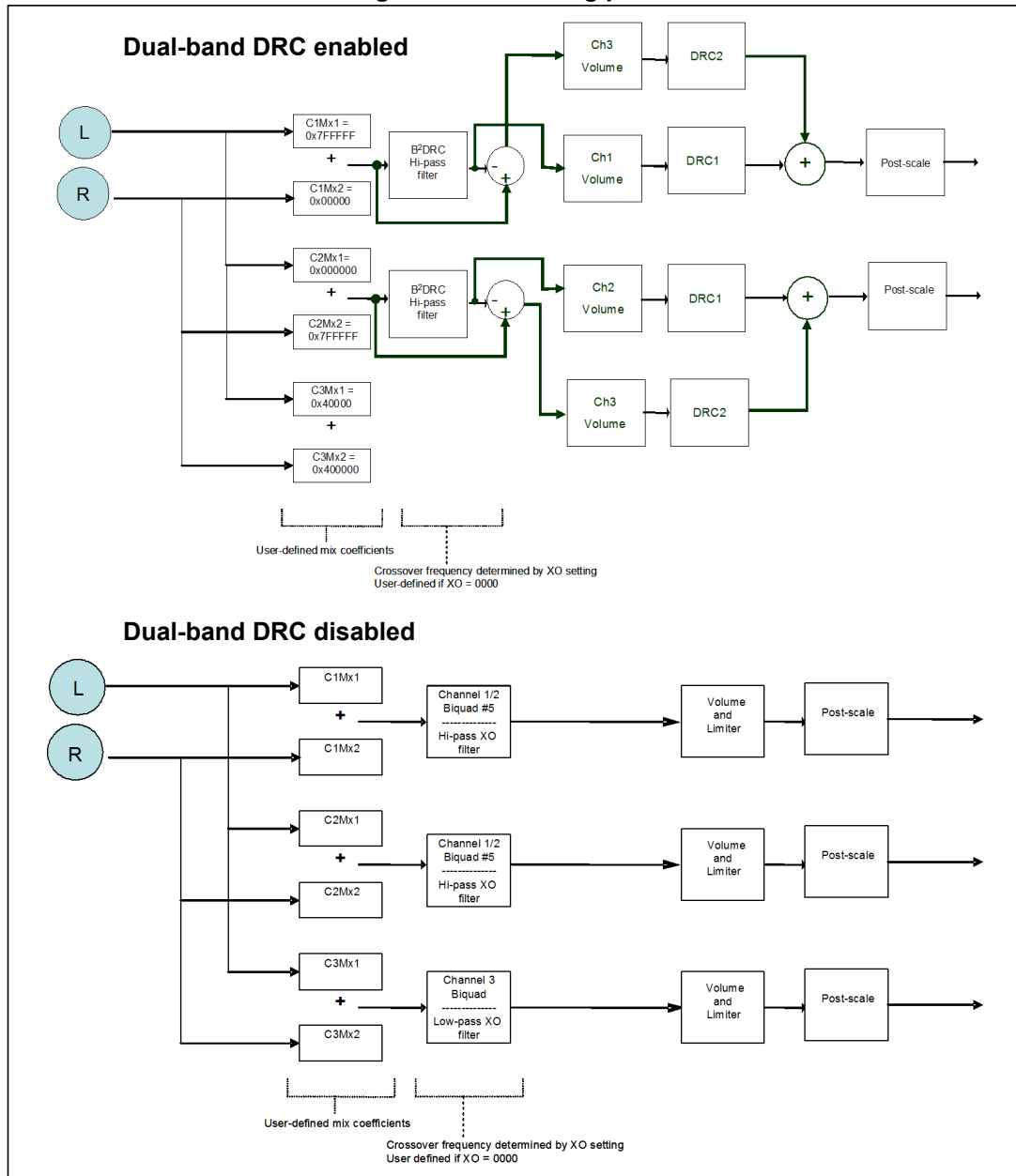

Figure 9. Processing part 2



6 I²C bus specification

The STA339BW supports the I²C protocol via the input ports SCL and SDA_IN (master to slave) and the output port SDA_OUT (slave to master). This protocol defines any device that sends data on to the bus as a transmitter and any device that reads the data as a receiver. The device that controls the data transfer is known as the master and the other as the slave. The master always starts the transfer and provides the serial clock for synchronization. The STA339BW is always a slave device in all of its communications. It can operate at up to 400 kb/s (fast-mode bit rate). The STA339BW I²C interface is a slave only interface.

6.1 Communication protocol

6.1.1 Data transition or change

Data changes on the SDA line must only occur when the SCL clock is low. SDA transition while the clock is high is used to identify a START or STOP condition.

6.1.2 Start condition

START is identified by a high to low transition of the data bus SDA signal while the clock signal SCL is stable in the high state. A START condition must precede any command for data transfer.

6.1.3 Stop condition

STOP is identified by low to high transition of the data bus SDA signal while the clock signal SCL is stable in the high state. A STOP condition terminates communication between STA339BW and the bus master.

6.1.4 Data input

During the data input the STA339BW samples the SDA signal on the rising edge of clock SCL. For correct device operation the SDA signal must be stable during the rising edge of the clock and the data can change only when the SCL line is low.

6.2 Device addressing

To start communication between the master and the STA339BW, the master must initiate with a start condition. Following this, the master sends onto the SDA line 8-bits (MSB first) corresponding to the device select address and read or write mode.

The seven most significant bits are the device address identifiers, corresponding to the I²C bus definition. In the STA339BW the I²C interface has two device addresses depending on the SA port configuration, 0x38 when SA = 0, and 0x3A when SA = 1.

The eighth bit (LSB) identifies read or write operation RW, this bit is set to 1 in read mode and to 0 for write mode. After a START condition the STA339BW identifies on the bus the device address and if a match is found, acknowledges the identification on the SDA bus during the 9th bit time. The byte following the device identification byte is the internal space address.

6.3 Write operation

Following the START condition the master sends a device select code with the RW bit set to 0. The STA339BW acknowledges this and the writes for the byte of internal address. After receiving the internal byte address the STA339BW again responds with an acknowledgement.

6.3.1 Byte write

In the byte write mode the master sends one data byte, this is acknowledged by the STA339BW. The master then terminates the transfer by generating a STOP condition.

6.3.2 Multi-byte write

The multi-byte write modes can start from any internal address. The master generating a STOP condition terminates the transfer.

6.4 Read operation

6.4.1 Current address byte read

Following the START condition the master sends a device select code with the RW bit set to 1. The STA339BW acknowledges this and then responds by sending one byte of data. The master then terminates the transfer by generating a STOP condition.

6.4.2 Current address multi-byte read

The multi-byte read modes can start from any internal address. Sequential data bytes are read from sequential addresses within the STA339BW. The master acknowledges each data byte read and then generates a STOP condition terminating the transfer.

6.4.3 Random address byte read

Following the START condition the master sends a device select code with the RW bit set to 0. The STA339BW acknowledges this and then the master writes the internal address byte. After receiving, the internal byte address the STA339BW again responds with an acknowledgement. The master then initiates another START condition and sends the device select code with the RW bit set to 1. The STA339BW acknowledges this and then responds by sending one byte of data. The master then terminates the transfer by generating a STOP condition.

6.4.4 Random address multi-byte read

The multi-byte read modes could start from any internal address. Sequential data bytes are read from sequential addresses within the STA339BW. The master acknowledges each data byte read and then generates a STOP condition terminating the transfer.

6.4.5 Write mode sequence

Figure 10. Write mode sequence

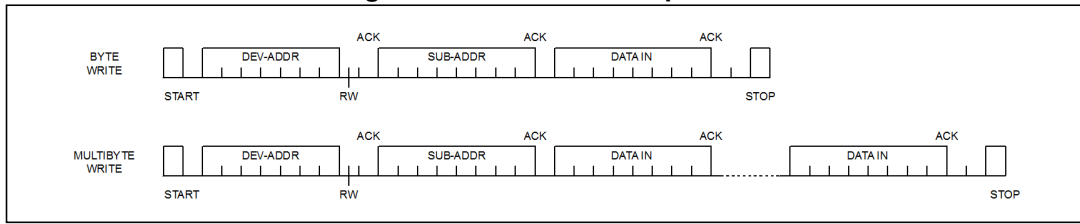

6.4.6 Read mode sequence

Figure 11. Read mode sequence

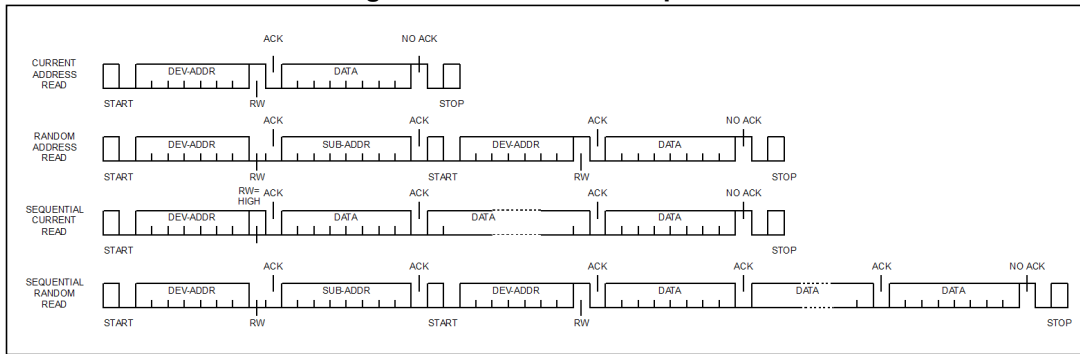

7 Register description

Table 10. Register summary

| Addr | Name | D7 | D6 | D5 | D4 | D3 | D2 | D1 | D0 |
|------|----------|----------|----------|----------|-------|----------|-------|----------|-------|
| 0x00 | CONFA | FDRB | TWAB | TWRB | IR1 | IR0 | MCS2 | MCS1 | MCS0 |
| 0x01 | CONFB | C2IM | C1IM | DSCKE | SAIFB | SAI3 | SAI2 | SAI1 | SAI0 |
| 0x02 | CONFC | OCRB | Reserved | CSZ3 | CSZ2 | CSZ1 | CSZ0 | OM1 | OM0 |
| 0x03 | CONFD | SME | ZDE | DRC | BQL | PSL | DSPB | DEMP | HPB |
| 0x04 | CONFE | SVE | ZCE | DCCV | PWMS | AME | NSBW | MPC | MPCV |
| 0x05 | CONFF | EAPD | PWDN | ECLE | LDTE | BCLE | IDE | OCFG1 | OCFG0 |
| 0x06 | MUTE/LOC | LOC1 | LOC0 | Reserved | | C3M | C2M | C1M | MMUTE |
| 0x07 | MVOL | MV7 | MV6 | MV5 | MV4 | MV3 | MV2 | MV1 | MV0 |
| 0x08 | C1VOL | C1V7 | C1V6 | C1V5 | C1V4 | C1V3 | C1V2 | C1V1 | C1V0 |
| 0x09 | C2VOL | C2V7 | C2V6 | C2V5 | C2V4 | C2V3 | C2V2 | C2V1 | C2V0 |
| 0x0A | C3VOL | C3V7 | C3V6 | C3V5 | C3V4 | C3V3 | C3V2 | C3V1 | C3V0 |
| 0x0B | AUTO1 | Reserved | | AMGC1 | AMGC0 | Reserved | | | |
| 0x0C | AUTO2 | XO3 | XO2 | XO1 | XO0 | AMAM2 | AMAM1 | AMAM0 | AMAME |
| 0x0D | AUTO3 | Reserved | | | | | | | |
| 0x0E | C1CFG | C1OM1 | C1OM0 | C1LS1 | C1LS0 | C1BO | C1VBP | C1EQBP | C1TCB |
| 0x0F | C2CFG | C2OM1 | C2OM0 | C2LS1 | C2LS0 | C2BO | C2VBP | C2EQBP | C2TCB |
| 0x10 | C3CFG | C3OM1 | C3OM0 | C3LS1 | C3LS0 | C3BO | C3VBP | Reserved | |
| 0x11 | TONE | TTC3 | TTC2 | TTC1 | TTC0 | BTC3 | BTC2 | BTC1 | BTC0 |
| 0x12 | L1AR | L1A3 | L1A2 | L1A1 | L1A0 | L1R3 | L1R2 | L1R1 | L1R0 |
| 0x13 | L1ATRT | L1AT3 | L1AT2 | L1AT1 | L1AT0 | L1RT3 | L1RT2 | L1RT1 | L1RT0 |
| 0x14 | L2AR | L2A3 | L2A2 | L2A1 | L2A0 | L2R3 | L2R2 | L2R1 | L2R0 |
| 0x15 | L2ATRT | L2AT3 | L2AT2 | L2AT1 | L2AT0 | L2RT3 | L2RT2 | L2RT1 | L2RT0 |
| 0x16 | CFADDR | Reserved | | CFA5 | CFA4 | CFA3 | CFA2 | CFA1 | CFA0 |
| 0x17 | B1CF1 | C1B23 | C1B22 | C1B21 | C1B20 | C1B19 | C1B18 | C1B17 | C1B16 |
| 0x18 | B1CF2 | C1B15 | C1B14 | C1B13 | C1B12 | C1B11 | C1B10 | C1B9 | C1B8 |
| 0x19 | B1CF3 | C1B7 | C1B6 | C1B5 | C1B4 | C1B3 | C1B2 | C1B1 | C1B0 |
| 0x1A | B2CF1 | C2B23 | C2B22 | C2B21 | C2B20 | C2B19 | C2B18 | C2B17 | C2B16 |
| 0x1B | B2CF2 | C2B15 | C2B14 | C2B13 | C2B12 | C2B11 | C2B10 | C2B9 | C2B8 |
| 0x1C | B2CF3 | C2B7 | C2B6 | C2B5 | C2B4 | C2B3 | C2B2 | C2B1 | C2B0 |
| 0x1D | A1CF1 | C3B23 | C3B22 | C3B21 | C3B20 | C3B19 | C3B18 | C3B17 | C3B16 |
| 0x1E | A1CF2 | C3B15 | C3B14 | C3B13 | C3B12 | C3B11 | C3B10 | C3B9 | C3B8 |
| 0x1F | A1CF3 | C3B7 | C3B6 | C3B5 | C3B4 | C3B3 | C3B2 | C3B1 | C3B0 |



Table 10. Register summary (continued)

| Addr | Name | D7 | D6 | D5 | D4 | D3 | D2 | D1 | D0 |
|------|----------|----------|----------|----------|----------|----------|----------|----------|----------|
| 0x20 | A2CF1 | C4B23 | C4B22 | C4B21 | C4B20 | C4B19 | C4B18 | C4B17 | C4B16 |
| 0x21 | A2CF2 | C4B15 | C4B14 | C4B13 | C4B12 | C4B11 | C4B10 | C4B9 | C4B8 |
| 0x22 | A2CF3 | C4B7 | C4B6 | C4B5 | C4B4 | C4B3 | C4B2 | C4B1 | C4B0 |
| 0x23 | B0CF1 | C5B23 | C5B22 | C5B21 | C5B20 | C5B19 | C5B18 | C5B17 | C5B16 |
| 0x24 | B0CF2 | C5B15 | C5B14 | C5B13 | C5B12 | C5B11 | C5B10 | C5B9 | C5B8 |
| 0x25 | B0CF3 | C5B7 | C5B6 | C5B5 | C5B4 | C5B3 | C5B2 | C5B1 | C5B0 |
| 0x26 | CFUD | Reserved | | | | RA | R1 | WA | W1 |
| 0x27 | MPCC1 | MPCC15 | MPCC14 | MPCC13 | MPCC12 | MPCC11 | MPCC10 | MPCC9 | MPCC8 |
| 0x28 | MPCC2 | MPCC7 | MPCC6 | MPCC5 | MPCC4 | MPCC3 | MPCC2 | MPCC1 | MPCC0 |
| 0x29 | DCC1 | DCC15 | DCC14 | DCC13 | DCC12 | DCC11 | DCC10 | DCC9 | DCC8 |
| 0x2A | DCC2 | DCC7 | DCC6 | DCC5 | DCC4 | DCC3 | DCC2 | DCC1 | DCC0 |
| 0x2B | FDRC1 | FDRC15 | FDRC14 | FDRC13 | FDRC12 | FDRC11 | FDRC10 | FDRC9 | FDRC8 |
| 0x2C | FDRC2 | FDRC7 | FDRC6 | FDRC5 | FDRC4 | FDRC3 | FDRC2 | FDRC1 | FDRC0 |
| 0x2D | STATUS | PLLUL | FAULT | UVFAULT | OVFAULT | OCFAULT | OCWARN | TFAULT | TWARN |
| 0x2E | Reserved | Reserved | | RO1BACT | R5BACT | R4BACT | R3BACT | R2BACT | R1BACT |
| 0x2F | Reserved | Reserved | | R01BEND | R5BEND | R4BEND | R3BEND | R2BEND | R1BEND |
| 0x30 | Reserved | Reserved | | | R5BBAD | R4BBAD | R3BBAD | R2BBAD | R1BBAD |
| 0x31 | EQCFG | XOB | Reserved | | AMGC3 | AMGC2 | Reserved | SEL1 | SEL0 |
| 0x32 | EATH1 | EATHEN1 | EATH1[6] | EATH1[5] | EATH1[4] | EATH1[3] | EATH1[2] | EATH1[1] | EATH1[0] |
| 0x33 | ERTH1 | ERTHEN1 | ERTH1[6] | ERTH1[5] | ERTH1[4] | ERTH1[3] | ERTH1[2] | ERTH1[1] | ERTH1[0] |
| 0x34 | EATH2 | EATHEN2 | EATH2[6] | EATH2[5] | EATH2[4] | EATH2[3] | EATH2[2] | EATH2[1] | EATH2[0] |
| 0x35 | ERTH2 | ERTHEN2 | ERTH2[6] | ERTH2[5] | ERTH2[4] | ERTH2[3] | ERTH2[2] | ERTH2[1] | ERTH2[0] |
| 0x36 | CONFX | MDRC[1] | MDRC[0] | PS48DB | XAR1 | XAR2 | BQ5 | BQ6 | BQ7 |
| 0x37 | SVCA | Reserved | | SVUPE | SVUP[4] | SVUP[3] | SVUP[2] | SVUP[1] | SVUP[0] |
| 0x38 | SVCB | Reserved | | SVDWE | SVDW[4] | SVDW[3] | SVDW[2] | SVDW[1] | SVDW[0] |
| 0x39 | RMS0A | R_C0[23] | R_C0[22] | R_C0[21] | R_C0[20] | R_C0[19] | R_C0[18] | R_C0[17] | R_C0[16] |
| 0x3A | RMS0B | R_C0[15] | R_C0[14] | R_C0[13] | R_C0[12] | R_C0[11] | R_C0[10] | R_C0[9] | R_C0[8] |
| 0x3B | RMS0C | R_C0[7] | R_C0[6] | R_C0[5] | R_C0[4] | R_C0[3] | R_C0[2] | R_C0[1] | R_C0[0] |
| 0x3C | RMS1A | R_C1[23] | R_C1[22] | R_C1[21] | R_C1[20] | R_C1[19] | R_C1[18] | R_C1[17] | R_C1[16] |
| 0x3D | RMS1B | R_C1[15] | R_C1[14] | R_C1[13] | R_C1[12] | R_C1[11] | R_C1[10] | R_C1[9] | R_C1[8] |
| 0x3E | RMS1C | R_C1[7] | R_C1[6] | R_C1[5] | R_C1[4] | R_C1[3] | R_C1[2] | R_C1[1] | R_C1[0] |

7.1 Configuration register A (addr 0x00)

| | | | | | | | |
|------|------|------|-----|-----|------|------|------|
| D7 | D6 | D5 | D4 | D3 | D2 | D1 | D0 |
| FDRB | TWAB | TWRB | IR1 | IR0 | MCS2 | MCS1 | MCS0 |
| 0 | 1 | 1 | 0 | 0 | 0 | 1 | 1 |

7.1.1 Master clock select

Table 11. Master clock select

| Bit | R/W | RST | Name | Description |
|-----|-----|-----|------|--|
| 0 | R/W | 1 | MCS0 | Selects the ratio between the input I ² S sample frequency and the input clock. |
| 1 | R/W | 1 | MCS1 | |
| 2 | R/W | 0 | MCS2 | |

The STA339BW supports sample rates of 32 kHz, 44.1 kHz, 48 kHz, 88.2 kHz, 96 kHz, 176.4 kHz, and 192 kHz. Therefore the internal clock is:

- 32.768 MHz for 32 kHz
- 45.1584 MHz for 44.1 kHz, 88.2 kHz, and 176.4 kHz
- 49.152 MHz for 48 kHz, 96 kHz, and 192 kHz

The external clock frequency provided to the XTI pin must be a multiple of the input sample frequency (f_s).

The relationship between the input clock and the input sample rate is determined by both the MCSx and the IR (input rate) register bits. The MCSx bits determine the PLL factor generating the internal clock and the IR bit determines the oversampling ratio used internally.

Table 12. Input sampling rates

| Input sample rate f_s (kHz) | IR | MCS[2:0] | | | | | |
|----------------------------------|----|-------------|-------------|-------------|-------------|-------------|-------------|
| | | 101 | 100 | 011 | 010 | 001 | 000 |
| - | - | | | | | | |
| 32, 44.1, 48 | 00 | 576 * f_s | 128 * f_s | 256 * f_s | 384 * f_s | 512 * f_s | 768 * f_s |
| 88.2, 96 | 01 | NA | 64 * f_s | 128 * f_s | 192 * f_s | 256 * f_s | 384 * f_s |
| 176.4, 192 | 1X | NA | 32 * f_s | 64 * f_s | 96 * f_s | 128 * f_s | 192 * f_s |

7.1.2 Interpolation ratio select

Table 13. Internal interpolation ratio

| Bit | R/W | RST | Name | Description |
|-----|-----|-----|----------|---|
| 4:3 | R/W | 00 | IR [1:0] | Selects internal interpolation ratio based on input I ² S sample frequency |

The STA339BW has variable interpolation (oversampling) settings such that internal processing and FFX output rates remain consistent. The first processing block interpolates by either 2-times or 1-time (pass-through) or provides a 2-times downsample. The oversampling ratio of this interpolation is determined by the IR bits.

Table 14. IR bit settings as a function of input sample rate

| Input sample rate fs (kHz) | IR | 1st stage interpolation ratio |
|----------------------------|----|-------------------------------|
| 32 | 00 | 2 times oversampling |
| 44.1 | 00 | 2 times oversampling |
| 48 | 00 | 2 times oversampling |
| 88.2 | 01 | Pass-through |
| 96 | 01 | Pass-through |
| 176.4 | 10 | 2 times downsampling |
| 192 | 10 | 2 times downsampling |

7.1.3 Thermal warning recovery bypass

Table 15. Thermal warning recovery bypass

| Bit | R/W | RST | Name | Description |
|-----|-----|-----|------|---|
| 5 | R/W | 1 | TWRB | 0: Thermal warning recovery enabled 1: Thermal warning recovery disabled |

If the thermal warning adjustment is enabled (TWAB = 0), then the thermal warning recovery determines if the -3 dB output limit is removed when thermal warning is negative.

If TWRB = 0 and TWAB = 0, then when a thermal warning disappears the -3 dB output limit is removed and the gain is added back to the system. If TWRB = 1 and TWAB = 0, then when a thermal warning disappears the -3 dB output limit remains until TWRB is changed to zero or the device is reset.

7.1.4 Thermal warning adjustment bypass

Table 16. Thermal warning adjustment bypass

| Bit | R/W | RST | Name | Description |
|-----|-----|-----|------|---|
| 6 | R/W | 1 | TWAB | 0: Thermal warning adjustment enabled 1: Thermal warning adjustment disabled |

The on-chip STA339BW power output block provides feedback to the digital controller using inputs to the power control block. Input TWARN is used to indicate a thermal warning condition. When TWARN is asserted (set to 0) for a period of time greater than 400 ms, the power control block forces a -3 dB output limit (determined by TWOCL in the coefficient RAM) to the modulation limit in an attempt to eliminate the thermal warning condition. Once the thermal warning output limit adjustment is applied, it remains in this state until reset, unless FDRB = 0.

7.1.5 Fault detect recovery bypass

Table 17. Fault detect recovery bypass

| Bit | R/W | RST | Name | Description |
|-----|-----|-----|------|---|
| 7 | R/W | 0 | FDRB | 0: fault detect recovery enabled 1: fault detect recovery disabled |

The on-chip STA339BW power output block provides feedback to the digital controller using inputs to the power control block. The FAULT input is used to indicate a fault condition (either overcurrent or thermal). When FAULT is asserted (set to 0), the power control block attempts a recovery from the fault by asserting the tri-state output (setting it to 0 which directs the power output block to begin recovery), holds it at 0 for period of time in the range of 0.1 ms to 1 second as defined by the fault-detect recovery constant register (FDRC registers 0x2B-0x2C), then toggles it back to 1. This sequence is repeated as long as the fault indication exists. This feature is enabled by default but can be bypassed by setting the FDRB control bit to 1.

7.2 Configuration register B (addr 0x01)

| D7 | D6 | D5 | D4 | D3 | D2 | D1 | D0 |
|------|------|-------|-------|------|------|------|------|
| C2IM | C1IM | DSCKE | SAIFB | SAI3 | SAI2 | SAI1 | SAI0 |
| 1 | 0 | 0 | 0 | 0 | 0 | 0 | 0 |

7.2.1 Serial audio input interface format

Table 18. Serial audio input interface

| Bit | R/W | RST | Name | Description |
|-----|-----|-----|------|--|
| 0 | R/W | 0 | SAI0 | Determines the interface format of the input serial digital audio interface. |
| 1 | R/W | 0 | SAI1 | |
| 2 | R/W | 0 | SAI2 | |
| 3 | R/W | 0 | SAI3 | |

7.2.2 Serial data interface

The STA339BW audio serial input was designed to interface with standard digital audio components and to accept a number of serial data formats. STA339BW always acts as slave when receiving audio input from standard digital audio components. Serial data for two channels is provided using three inputs: left/right clock LRCKI, serial clock BICKI, and serial data 1 and 2 SDI12.

The SAI bits (D3 to D0) and the SAIFB bit (D4) are used to specify the serial data format. The default serial data format is I²S, MSB-first. Available formats are shown in the tables and figure that follow.

7.2.3 Serial data first bit

Table 19. Serial data first bit

| SAIFB | Format |
|-------|-----------|
| 0 | MSB-first |
| 1 | LSB-first |

Table 20. Supported serial audio input formats for MSB-first (SAIFB = 0)

| BICKI | SAI [3:0] | SAIFB | Interface format |
|---------|-----------|-------|------------------------------------|
| 32 * fs | 0000 | 0 | I ² S 15-bit data |
| | 0001 | 0 | Left/right-justified 16-bit data |
| 48 * fs | 0000 | 0 | I ² S 16 to 23-bit data |
| | 0001 | 0 | Left-justified 16 to 24-bit data |
| | 0010 | 0 | Right-justified 24-bit data |
| | 0110 | 0 | Right-justified 20-bit data |
| | 1010 | 0 | Right-justified 18-bit data |
| | 1110 | 0 | Right-justified 16-bit data |
| 64 * fs | 0000 | 0 | I ² S 16 to 24-bit data |
| | 0001 | 0 | Left-justified 16 to 24-bit data |
| | 0010 | 0 | Right-justified 24-bit data |
| | 0110 | 0 | Right-justified 20-bit data |
| | 1010 | 0 | Right-justified 18-bit data |
| | 1110 | 0 | Right-justified 16-bit data |

Table 21. Supported serial audio input formats for LSB-first (SAIFB = 1)

| BICKI | SAI [3:0] | SAIFB | Interface format |
|---------|-----------|-----------------------------|--|
| 32 * fs | 1100 | 1 | I ² S 15-bit data |
| | 1110 | 1 | Left/right-justified 16-bit data |
| 48 * fs | 0100 | 1 | I ² S 23-bit data |
| | 0100 | 1 | I ² S 20-bit data |
| | 1000 | 1 | I ² S 18-bit data |
| | 1100 | 1 | LSB first I ² S 16-bit data |
| | 0001 | 1 | Left-justified 24-bit data |
| | 0101 | 1 | Left-justified 20-bit data |
| | 1001 | 1 | Left-justified 18-bit data |
| | 1101 | 1 | Left-justified 16-bit data |
| | 0010 | 1 | Right-justified 24-bit data |
| | 0110 | 1 | Right-justified 20-bit data |
| | 1010 | 1 | Right-justified 18-bit data |
| 1110 | 1 | Right-justified 16-bit data | |
| 64 * fs | 0000 | 1 | I ² S 24-bit data |
| | 0100 | 1 | I ² S 20-bit data |
| | 1000 | 1 | I ² S 18-bit data |
| | 1100 | 1 | LSB first I ² S 16-bit data |
| | 0001 | 1 | Left-justified 24-bit data |
| | 0101 | 1 | Left-justified 20-bit data |
| | 1001 | 1 | Left-justified 18-bit data |
| | 1101 | 1 | Left-justified 16-bit data |
| | 0010 | 1 | Right-justified 24-bit data |
| | 0110 | 1 | Right-justified 20-bit data |
| | 1010 | 1 | Right-justified 18-bit data |
| 1110 | 1 | Right-justified 16-bit data | |

To make the STA339BW work properly, the serial audio interface LRCKI clock must be synchronous to the PLL output clock. It means that:

- the frequency of PLL clock / frequency of LRCKI = $N \pm 4$ cycles, where N depends on the settings in [Table 14 on page 29](#)
- the PLL must be locked.

If these two conditions are not met, and bit IDE of register address 0x05 is set to 1, the STA339BW immediately mutes the I²S PCM data out (provided to the processing block) and it freezes any active processing task.

To avoid any audio side effects (like pop noise), it is strongly recommended to soft mute any audio streams flowing into STA339BW data path before the desynchronization event happens. At the same time any processing related to the I²C configuration should be issued only after the serial audio interface and the internal PLL are synchronous again.

Note: Any mute or volume change causes some delay in the completion of the I²C operation due to the soft volume feature. The soft volume phase change must be finished before any clock desynchronization.

7.2.4 Delay serial clock enable

Table 22. Delay serial clock enable

| Bit | R/W | RST | Name | Description |
|-----|-----|-----|-------|---|
| 5 | R/W | 0 | DSCKE | 0: No serial clock delay 1: Serial clock delay by 1 core clock cycle to tolerate anomalies in some I ² S master devices |

7.2.5 Channel input mapping

Table 23. Channel input mapping

| Bit | R/W | RST | Name | Description |
|-----|-----|-----|------|---|
| 6 | R/W | 0 | C1IM | 0: Processing channel 1 receives Left I ² S Input 1: Processing channel 1 receives Right I ² S Input |
| 7 | R/W | 1 | C2IM | 0: Processing channel 2 receives Left I ² S Input 1: Processing channel 2 receives Right I ² S Input |

Each channel received via I²S can be mapped to any internal processing channel via the Channel Input Mapping registers. This allows for flexibility in processing. The default settings of these registers map each I²S input channel to its corresponding processing channel.

7.3 Configuration register C (addr 0x02)

| | | | | | | | |
|------|----------|------|------|------|------|-----|-----|
| D7 | D6 | D5 | D4 | D3 | D2 | D1 | D0 |
| OCRB | Reserved | CSZ3 | CSZ2 | CSZ1 | CSZ0 | OM1 | OM0 |
| 1 | 0 | 0 | 1 | 1 | 1 | 1 | 1 |

7.3.1 FFX power output mode

Table 24. FFX power output mode

| Bit | R/W | RST | Name | Description |
|-----|-----|-----|------|--------------------------------------|
| 0 | R/W | 1 | OM0 | Selects configuration of FFX output. |
| 1 | R/W | 1 | OM1 | |

The FFX power output mode selects how the FFX output timing is configured. Different power devices use different output modes.

Table 25. Output modes

| OM[1,0] | Output stage mode |
|---------|--|
| 00 | Drop compensation |
| 01 | Discrete output stage - tapered compensation |
| 10 | Full power mode |
| 11 | Variable drop compensation (CSZx bits) |

7.3.2 FFX compensating pulse size register

Table 26. FFX compensating pulse size bits

| Bit | R/W | RST | Name | Description |
|-----|-----|-----|------|--|
| 2 | R/W | 1 | CSZ0 | When OM[1,0] = 11, this register determines the size of the FFX compensating pulse from 0 clock ticks to 15 clock periods. |
| 3 | R/W | 1 | CSZ1 | |
| 4 | R/W | 1 | CSZ2 | |
| 5 | R/W | 0 | CSZ3 | |

Table 27. Compensating pulse size

| CSZ[3:0] | Compensating pulse size |
|----------|---|
| 0000 | 0 ns (0 tick) compensating pulse size |
| 0001 | 20 ns (1 tick) clock period compensating pulse size |
| ... | ... |
| 1111 | 300 ns (15 tick) clock period compensating pulse size |

7.3.3 Overcurrent warning detect adjustment bypass

Table 28. Overcurrent warning bypass

| Bit | R/W | RST | Name | Description |
|-----|-----|-----|------|---|
| 7 | R/W | 1 | OCRB | 0: overcurrent warning adjustment enabled 1: overcurrent warning adjustment disabled |

The OCWARN input is used to indicate an overcurrent warning condition. When OCWARN is asserted (set to 0), the power control block forces an adjustment to the modulation limit (default is -3 dB) in an attempt to eliminate the overcurrent warning condition. Once the overcurrent warning volume adjustment is applied, it remains in this state until reset is applied. The level of adjustment can be changed via the TWOCL (thermal warning / overcurrent limit) setting which is address 0x37 of the user defined coefficient RAM.

7.4 Configuration register D (addr 0x03)

| D7 | D6 | D5 | D4 | D3 | D2 | D1 | D0 |
|-----|-----|-----|-----|-----|------|------|-----|
| SME | ZDE | DRC | BQL | PSL | DSPB | DEMP | HPB |
| 0 | 1 | 0 | 0 | 0 | 0 | 0 | 0 |

7.4.1 High-pass filter bypass

Table 29. High-pass filter bypass

| Bit | R/W | RST | Name | Description |
|-----|-----|-----|------|---|
| 0 | R/W | 0 | HPB | Setting of one bypasses internal AC coupling digital high-pass filter |

The STA339BW features an internal digital high-pass filter for the purpose of AC coupling. The purpose of this filter is to prevent DC signals from passing through a FFX amplifier. DC signals can cause speaker damage. When HPB = 0, this filter is enabled.

7.4.2 De-emphasis

Table 30. De-emphasis

| Bit | R/W | RST | Name | Description |
|-----|-----|-----|------|--|
| 1 | R/W | 0 | DEMP | 0: No de-emphasis 1: Enable de-emphasis on all channels |

7.4.3 DSP bypass

Table 31. DSP bypass

| Bit | R/W | RST | Name | Description |
|-----|-----|-----|------|--|
| 2 | R/W | 0 | DSPB | 0: Normal operation 1: Bypass of biquad and bass/treble functions |

Setting the DSPB bit bypasses the EQ function of the STA339BW.

7.4.4 Post-scale link

Table 32. Post-scale link

| Bit | R/W | RST | Name | Description |
|-----|-----|-----|------|---|
| 3 | R/W | 0 | PSL | 0: Each channel uses individual post-scale value 1: Each channel uses channel 1 post-scale value |

Post-scale functionality can be used for power-supply error correction. For multi-channel applications running off the same power-supply, the post-scale values can be linked to the value of channel 1 for ease of use and update the values faster.

7.4.5 Biquad coefficient link

Table 33. Biquad coefficient link

| Bit | R/W | RST | Name | Description |
|-----|-----|-----|------|--|
| 4 | R/W | 0 | BQL | 0: Each channel uses coefficient values 1: Each channel uses channel 1 coefficient values |

For ease of use, all channels can use the biquad coefficients loaded into the Channel-1 coefficient RAM space by setting the BQL bit to 1. Therefore, any EQ updates only have to be performed once.

7.4.6 Dynamic range compression/anti-clipping bit

Table 34. Dynamic range compression/anti-clipping bit

| Bit | R/W | RST | Name | Description |
|-----|-----|-----|------|--|
| 5 | R/W | 0 | DRC | 0: Limiters act in anti-clipping mode 1: Limiters act in dynamic range compression mode |

Both limiters can be used in one of two ways, anti-clipping or dynamic range compression. When used in anti-clipping mode the limiter threshold values are constant and dependent on the limiter settings. In dynamic range compression mode the limiter threshold values vary with the volume settings allowing a nighttime listening mode that provides a reduction in the dynamic range regardless of the volume level.

7.4.7 Zero-detect mute enable

Table 35. Zero-detect mute enable

| Bit | R/W | RST | Name | Description |
|-----|-----|-----|------|---|
| 6 | R/W | 1 | ZDE | Setting of 1 enables the automatic zero-detect mute |

Setting the ZDE bit enables the zero-detect automatic mute. The zero-detect circuit looks at the data for each processing channel at the output of the crossover (bass management) filter. If any channel receives 2048 consecutive zero value samples (regardless of fs) then that individual channel is muted if this function is enabled.

7.4.8 Submix mode enable

Table 36. Submix mode enable

| Bit | R/W | RST | Name | Description |
|-----|-----|-----|------|---|
| 7 | R/W | 0 | SME | 0: Sub Mix into Left/Right disabled 1: Sub Mix into Left/Right enabled |

7.5 Configuration register E (addr 0x04)

| D7 | D6 | D5 | D4 | D3 | D2 | D1 | D0 |
|-----|-----|------|------|-----|------|-----|------|
| SVE | ZCE | DCCV | PWMS | AME | NSBW | MPC | MPCV |
| 1 | 1 | 0 | 0 | 0 | 0 | 1 | 0 |

7.5.1 Max power correction variable

Table 37. Max power correction variable

| Bit | R/W | RST | Name | Description |
|-----|-----|-----|------|---|
| 0 | R/W | 0 | MPCV | 0: Use standard MPC coefficient 1: Use MPCC bits for MPC coefficient |

7.5.2 Max power correction

Table 38. Max power correction

| Bit | R/W | RST | Name | Description |
|-----|-----|-----|------|---|
| 1 | R/W | 1 | MPC | Setting of 1 enables Power Bridge correction for THD reduction near maximum power output. |

Setting the MPC bit turns on special processing that corrects the STA339BW power device at high power. This mode should lower the THD+N of a full FFX system at maximum power output and slightly below. If enabled, MPC is operational in all output modes except tapered (OM[1,0] = 01) and binary. When OCFG = 00, MPC will not effect channels 3 and 4, the line-out channels.

7.5.3 Noise-shaper bandwidth selection

Table 39. Noise-shaper bandwidth selection

| Bit | R/W | RST | Name | Description |
|-----|-----|-----|------|---|
| 2 | R/W | 0 | NSBW | 1: Third order NS 0: Fourth order NS |

7.5.4 AM mode enable

Table 40. AM mode enable

| Bit | R/W | RST | Name | Description |
|-----|-----|-----|------|--|
| 3 | R/W | 0 | AME | 0: Normal FFX operation. 1: AM reduction mode FFX operation |

STA339BW features aFFX processing mode that minimizes the amount of noise generated in frequency range of AM radio. This mode is intended for use when FFX is operating in a device with an AM tuner active. The SNR of the FFX processing is reduced to approximately 83 dB in this mode, which is still greater than the SNR of AM radio.

7.5.5 PWM speed mode

Table 41. PWM speed mode

| Bit | R/W | RST | Name | Description |
|-----|-----|-----|------|---|
| 4 | R/W | 0 | PWMS | 0: Normal speed (384 kHz) all channels 1: Odd speed (341.3 kHz) all channels |

7.5.6 Distortion compensation variable enable

Table 42. Distortion compensation variable enable

| Bit | R/W | RST | Name | Description |
|-----|-----|-----|------|--|
| 5 | R/W | 0 | DCCV | 0: Use preset DC coefficient 1: Use DCC coefficient |

7.5.7 Zero-crossing volume enable

Table 43. Zero-crossing volume enable

| Bit | R/W | RST | Name | Description |
|-----|-----|-----|------|---|
| 6 | R/W | 1 | ZCE | 1: Volume adjustments only occur at digital zero-crossings 0: Volume adjustments occur immediately |

The ZCE bit enables zero-crossing volume adjustments. When volume is adjusted on digital zero-crossings no clicks are audible.

7.5.8 Soft volume update enable

Table 44. Soft volume update enable

| Bit | R/W | RST | Name | Description |
|-----|-----|-----|------|---|
| 7 | R/W | 1 | SVE | 1: Volume adjustments ramp according to SVR settings 0: Volume adjustments occur immediately |

7.6 Configuration register F (addr 0x05)

| D7 | D6 | D5 | D4 | D3 | D2 | D1 | D0 |
|------|------|------|------|------|-----|-------|-------|
| EAPD | PWDN | ECLE | LDTE | BCLE | IDE | OCFG1 | OCFG0 |
| 0 | 1 | 0 | 1 | 1 | 1 | 0 | 0 |

7.6.1 Output configuration

Table 45. Output configuration

| Bit | R/W | RST | Name | Description |
|-----|-----|-----|-------|----------------------------------|
| 0 | R/W | 0 | OCFG0 | Selects the output configuration |
| 1 | R/W | 0 | OCFG1 | |

Table 46. Output configuration engine selection

| OCFG[1:0] | Output configuration | Config pin |
|-----------|---|------------|
| 00 | 2 channel (full-bridge) power, 2 channel data-out: 1A/1B → 1A/1B 2A/2B → 2A/2B LineOut1 → 3A/3B LineOut2 → 4A/4B Line Out Configuration determined by LOC register | 0 |
| 01 | 2(Half-Bridge).1(Full-Bridge) On-Board Power: 1A → 1A Binary 0° 2A → 1B Binary 90° 3A/3B → 2A/2B Binary 45° 1A/B → 3A/B Binary 0° 2A/B → 4A/B Binary 90° | 0 |
| 10 | 2 Channel (Full-Bridge) Power, 1 Channel FFX: 1A/1B → 1A/1B 2A/2B → 2A/2B 3A/3B → 3A/3B EAPDEXT and TWARDNEXT Active | 0 |
| 11 | 1 Channel Mono-Parallel: 3A → 1A/1B w/ C3BO 45° 3B → 2A/2B w/ C3BO 45° 1A/1B → 3A/3B 2A/2B → 4A/4B | 1 |

Note: To the left of the arrow is the processing channel. When using channel output mapping, any of the three processing channel outputs can be used for any of the three inputs.

Figure 12. OCFG = 00 (default value)

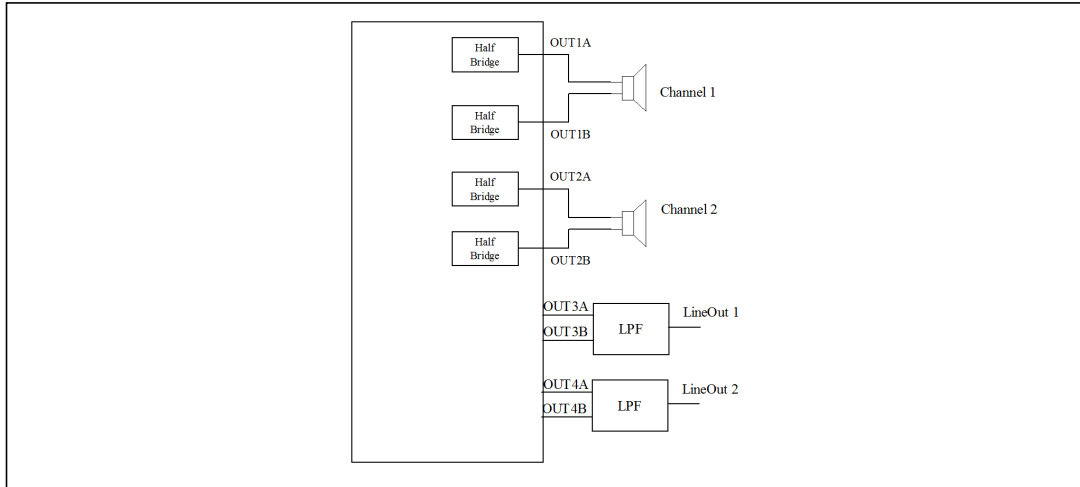

Figure 13. OCFG = 01

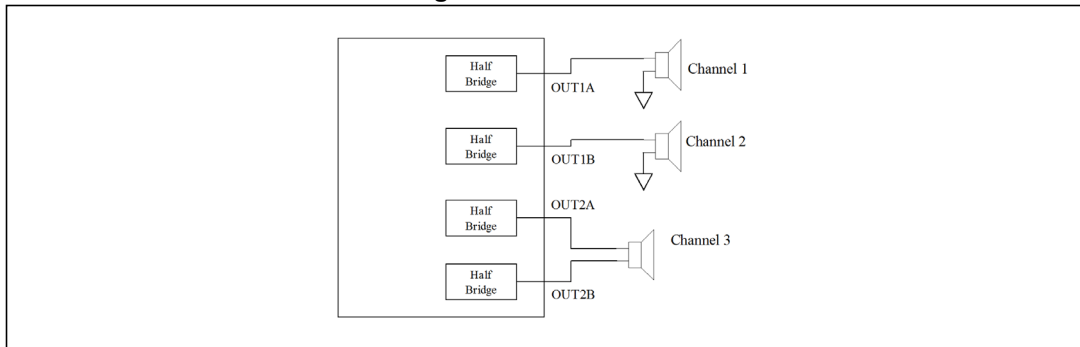

Figure 14. OCFG = 10

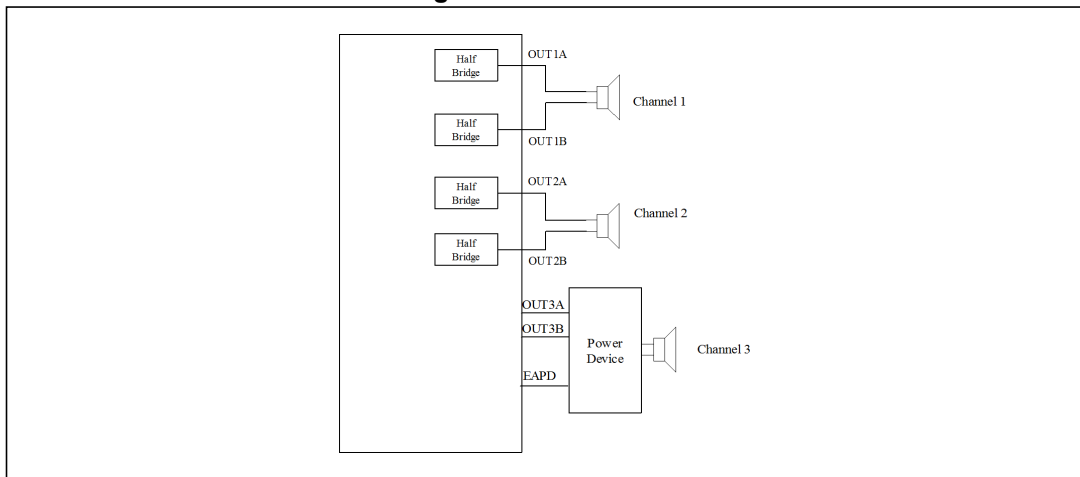
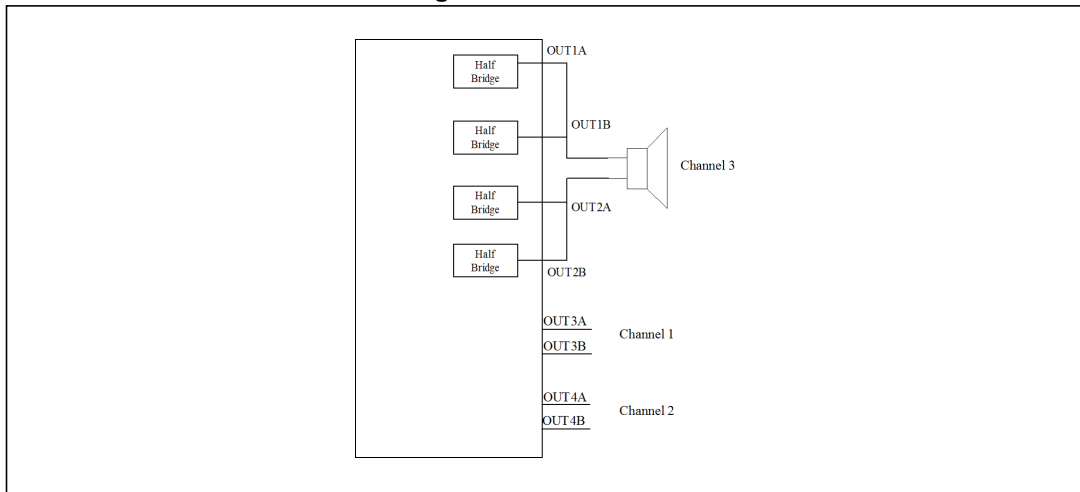
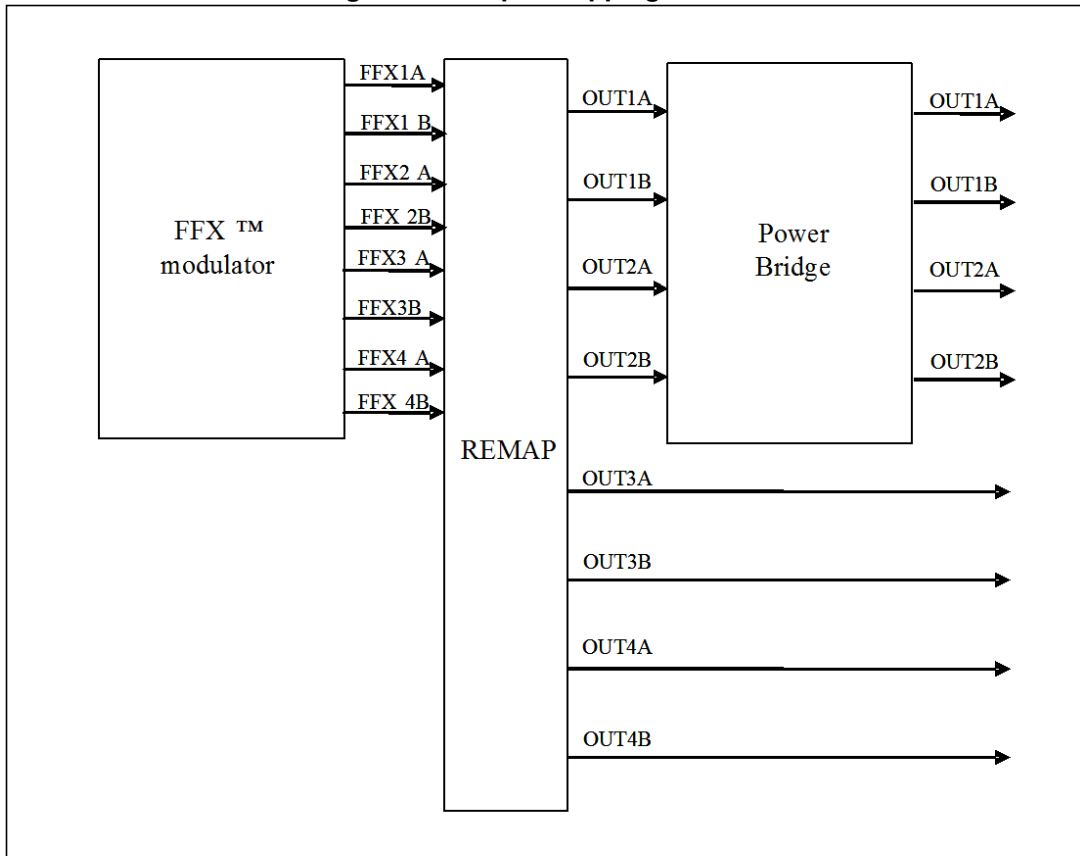

Figure 15. OCFG = 11



The STA339BW can be configured to support different output configurations. For each PWM output channel a PWM slot is defined. A PWM slot is always $1 / (8 * f_s)$ seconds length. The PWM slot define the maximum extension for PWM rise and fall edge, that is, rising edge as far as the falling edge cannot range outside PWM slot boundaries.

Figure 16. Output mapping scheme



For each configuration the PWM signals from the digital driver are mapped in different ways to the power stage:

2.0 channels, two full bridges (OCFG = 00)

- FFX1A -> OUT1A
- FFX1B -> OUT1B
- FFX2A -> OUT2A
- FFX2B -> OUT2B
- FFX3A -> OUT3A
- FFX3B -> OUT3B
- FFX4A -> OUT4A
- FFX4B -> OUT4B
- FFX1A/1B configured as ternary
- FFX2A/2B configured as ternary
- FFX3A/3B configured as lineout ternary
- FFX4A/4B configured as lineout ternary

On channel 3 line out (LOC bits = 00) the same data as channel 1 processing is sent. On channel 4 line out (LOC bits = 00) the same data as channel 2 processing is sent. In this configuration, volume control or EQ have no effect on channels 3 and 4.

In this configuration the PWM slot phase is the following as shown in *Figure 17*.

Figure 17. 2.0 channels (OCFG = 00) PWM slots

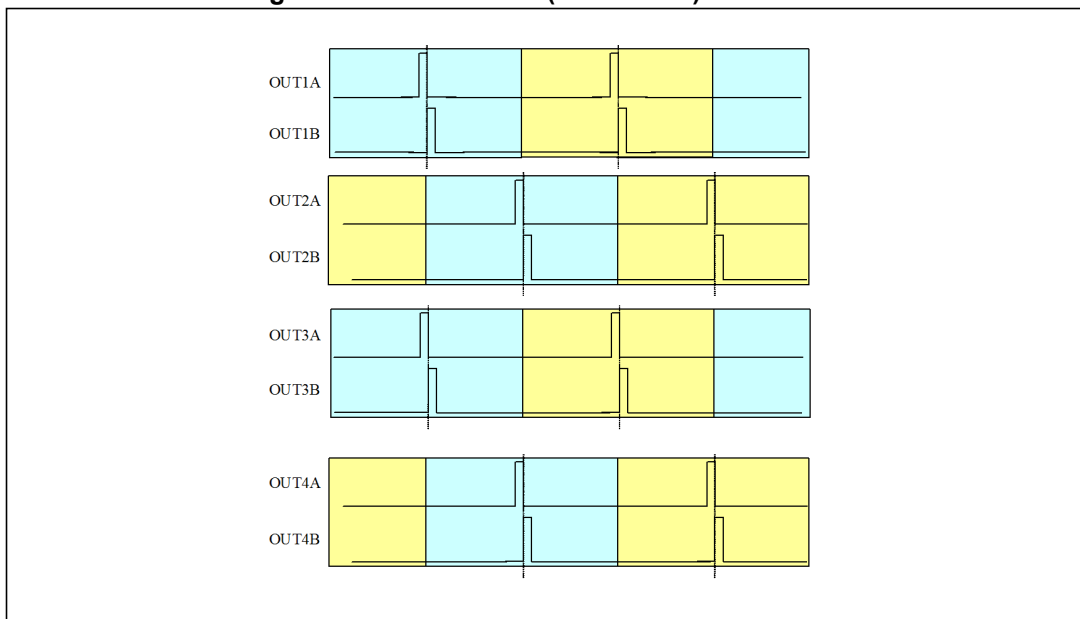

2.1 channels, two half bridges + one full bridge (OCFG = 01)

- FFX1A -> OUT1A
- FFX2A -> OUT1B
- FFX3A -> OUT2A
- FFX3B -> OUT2B
- FFX1A -> OUT3A
- FFX1B -> OUT3B
- FFX2A -> OUT4A
- FFX2B -> OUT4B
- FFX1A/1B configured as binary
- FFX2A/2B configured as binary
- FFX3A/3B configured as binary
- FFX4A/4B is not used

In this configuration, channel 3 has full control (volume, EQ, etc...). On OUT3/OUT4 channels the channel 1 and channel 2 PWM are replicated.

In this configuration the PWM slot phase is the following as shown in *Figure 18*.

Figure 18. 2.1 channels (OCFG = 01) PWM slots

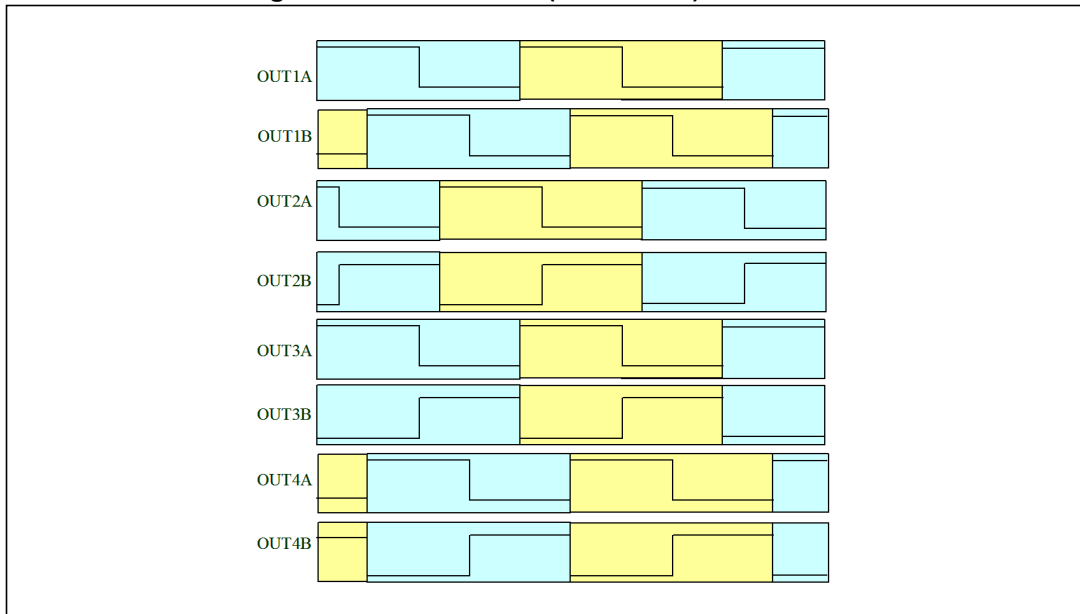

2.1 channels, two fullbridge + one external full bridge (OCFG = 10)

- FFX1A -> OUT1A
- FFX1B -> OUT1B
- FFX2A -> OUT2A
- FFX2B -> OUT2B
- FFX3A -> OUT3A
- FFX3B -> OUT3B
- EAPD -> OUT4A
- TWARN -> OUT4B
- FFX1A/1B configured as ternary
- FFX2A/2B configured as ternary
- FFX3A/3B configured as ternary
- FFX4A/4B is not used

In this configuration, channel 3 has full control (volume, EQ, etc...). On OUT4 channel the external bridge control signals are muxed.

In this configuration the PWM slot phase is the following as shown in *Figure 19*.

Figure 19. 2.1 channels (OCFG = 10) PWM slots

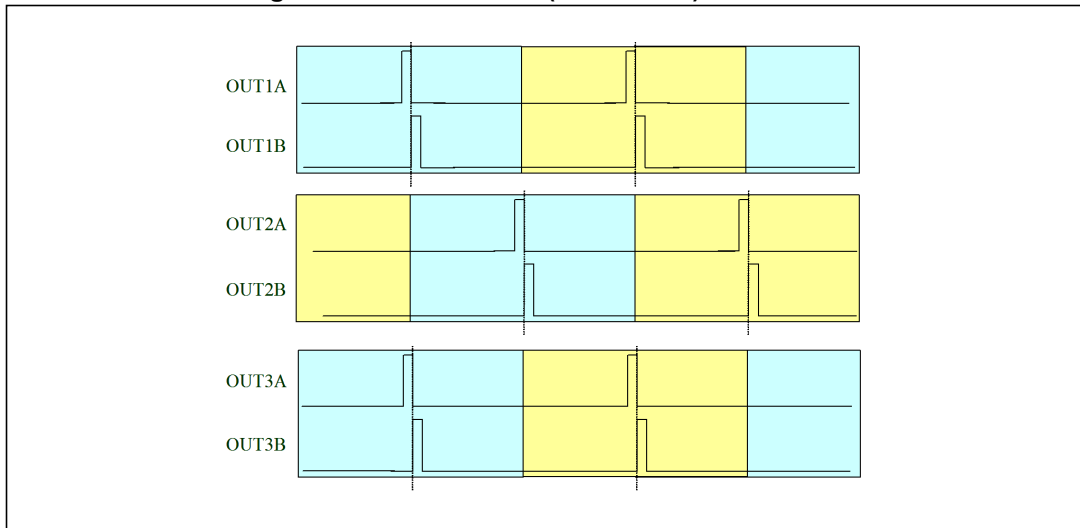

7.6.2 Invalid input detect mute enable

Table 47. Invalid input detect mute enable

| Bit | R/W | RST | Name | Description |
|-----|-----|-----|------|--|
| 2 | R/W | 1 | IDE | Setting of 1 enables the automatic invalid input detect mute |

Setting the IDE bit enables this function, which looks at the input I²S data and automatically mutes if the signals are perceived as invalid.

7.6.3 Binary output mode clock loss detection

Table 48. Binary output mode clock loss detection

| Bit | R/W | RST | Name | Description |
|-----|-----|-----|------|--|
| 3 | R/W | 1 | BCLE | Binary output mode clock loss detection enable |

Detects loss of input MCLK in binary mode and will output 50% duty cycle.

7.6.4 LRCK double trigger protection

Table 49. LRCK double trigger protection

| Bit | R/W | RST | Name | Description |
|-----|-----|-----|------|--|
| 4 | R/W | 1 | LDTE | LRCLK double trigger protection enable |

Actively prevents double trigger of LRCLK.

7.6.5 Auto EAPD on clock loss

Table 50. Auto EAPD on clock loss

| Bit | R/W | RST | Name | Description |
|-----|-----|-----|------|-------------------------|
| 5 | R/W | 0 | ECLE | Auto EAPD on clock loss |

When active, issues a power device power down signal (EAPD) on clock loss detection.

7.6.6 IC power down

Table 51. IC power down

| Bit | R/W | RST | Name | Description |
|-----|-----|-----|------|--|
| 7 | R/W | 1 | PWDN | 0: IC power down low-power condition 1: IC normal operation |

The PWDN register is used to place the IC in a low-power state. When PWDN is written as 0, the output begins a soft-mute. After the mute condition is reached, EAPD is asserted

to power down the power-stage, then the master clock to all internal hardware except the I²C block is gated. This places the IC in a very low power consumption state.

7.6.7 External amplifier power down

Table 52. External amplifier power down

| Bit | R/W | RST | Name | Description |
|-----|-----|-----|------|--|
| 7 | R/W | 0 | EAPD | 0: External power stage power down active 1: Normal operation |

The EAPD register directly disables/enables the internal power circuitry.

When EAPD = 0, the internal power section is placed on a low-power state (disabled). This register also controls the FFX4B/EAPD output pin when OCFG = 10.

7.7 Volume control registers (addr 0x06 - 0x0A)

7.7.1 Mute/line output configuration register

| D7 | D6 | D5 | D4 | D3 | D2 | D1 | D0 |
|------|------|----------|----|-----|-----|-----|-------|
| LOC1 | LOC0 | Reserved | | C3M | C2M | C1M | MMUTE |
| 0 | 0 | 0 | 0 | 0 | 0 | 0 | 0 |

Table 53. Line output configuration

| LOC[1:0] | Line output configuration |
|----------|---|
| 00 | Line output fixed - no volume, no EQ |
| 01 | Line output variable - CH3 volume effects line output, no EQ |
| 10 | Line output variable with EQ - CH3 volume effects line output |

Line output is only active when OCFG = 00. In this case LOC determines the line output configuration. The source of the line output is always the channel 1 and 2 inputs.

7.7.2 Master volume register

| D7 | D6 | D5 | D4 | D3 | D2 | D1 | D0 |
|-----|-----|-----|-----|-----|-----|-----|-----|
| MV7 | MV6 | MV5 | MV4 | MV3 | MV2 | MV1 | MV0 |
| 1 | 1 | 1 | 1 | 1 | 1 | 1 | 1 |

7.7.3 Channel 1 volume

| D7 | D6 | D5 | D4 | D3 | D2 | D1 | D0 |
|------|------|------|------|------|------|------|------|
| C1V7 | C1V6 | C1V5 | C1V4 | C1V3 | C1V2 | C1V1 | C1V0 |
| 0 | 1 | 1 | 0 | 0 | 0 | 0 | 0 |

7.7.4 Channel 2 volume

| | | | | | | | |
|------|------|------|------|------|------|------|------|
| D7 | D6 | D5 | D4 | D3 | D2 | D1 | D0 |
| C2V7 | C2V6 | C2V5 | C2V4 | C2V3 | C2V2 | C2V1 | C2V0 |
| 0 | 1 | 1 | 0 | 0 | 0 | 0 | 0 |

7.7.5 Channel 3 / line output volume

| | | | | | | | |
|------|------|------|------|------|------|------|------|
| D7 | D6 | D5 | D4 | D3 | D2 | D1 | D0 |
| C3V7 | C3V6 | C3V5 | C3V4 | C3V3 | C3V2 | C3V1 | C3V0 |
| 0 | 1 | 1 | 0 | 0 | 0 | 0 | 0 |

The Volume structure of the STA339BW consists of individual volume registers for each channel and a master volume register that provides an offset to each channels volume setting. The individual channel volumes are adjustable in 0.5 dB steps from +48 dB to -80 dB.

As an example if C3V = 0x00 or +48 dB and MV = 0x18 or -12 dB, then the total gain for channel 3 = +36 dB.

The master mute, when set to 1, mutes all channels at once, whereas the individual channel mutes (CxM) mutes only that channel. Both the master mute and the channel mutes provide a “soft mute” with the volume ramping down to mute in 4096 samples from the maximum volume setting at the internal processing rate (approximately 96 kHz).

A “hard (instantaneous) mute” can be obtained by programming a value of 0xFF (255) to any channel volume register or the master volume register. When volume offsets are provided via the master volume register any channel whose total volume is less than -80 dB is muted.

All changes in volume take place at zero-crossings when ZCE = 1 (*Configuration register E (addr 0x04) on page 37*) on a per channel basis as this creates the smoothest possible volume transitions. When ZCE = 0, volume updates occur immediately.

Table 54. Master volume offset as a function of MV[7:0]

| MV[7:0] | Volume offset from channel value |
|-----------------|----------------------------------|
| 00000000 (0x00) | 0 dB |
| 00000001 (0x01) | -0.5 dB |
| 00000010 (0x02) | -1 dB |
| ... | ... |
| 01001100 (0x4C) | -38 dB |
| ... | ... |
| 11111110 (0xFE) | -127.5 dB |
| 11111111 (0xFF) | Hard master mute |

Table 55. Channel volume as a function of CxV[7:0]

| CxV[7:0] | Volume |
|-----------------|-------------------|
| 00000000 (0x00) | +48 dB |
| 00000001 (0x01) | +47.5 dB |
| 00000010 (0x02) | +47 dB |
| ... | ... |
| 01011111 (0x5F) | +0.5 dB |
| 01100000 (0x60) | 0 dB |
| 01100001 (0x61) | -0.5 dB |
| ... | ... |
| 11010111 (0xD7) | -59.5 dB |
| 11011000 (0xD8) | -60 dB |
| 11011001 (0xD9) | -61 dB |
| 11011010 (0xDA) | -62 dB |
| ... | ... |
| 11101100 (0xEC) | -80 dB |
| 11101101 (0xED) | Hard channel mute |
| ... | ... |
| 11111111 (0xFF) | Hard channel mute |

7.8 Audio preset registers (addr 0x0B and 0x0C)

7.8.1 Audio preset register 1 (addr 0x0B)

| | | | | | | | |
|----------|----|---------|---------|----------|----|----|----|
| D7 | D6 | D5 | D4 | D3 | D2 | D1 | D0 |
| Reserved | | AMGC[1] | AMGC[0] | Reserved | | | |
| 0 | 0 | 0 | 0 | 0 | 0 | 0 | 0 |

Using AMGC[3:0] bits, attack and release thresholds and rates are automatically configured to properly fit application specific configurations. AMGC[3:2] is defined in register [EQ coefficients and DRC configuration register \(addr 0x31\) on page 66](#).

The AMGC[1:0] bits behave in two different ways depending on the value of AMGC[3:2]. When this value is 00 then bits AMGC[1:0] are defined below in [Table 56](#).

Table 56. Audio preset gain compression/limiters selection for AMGC[3:2] = 00

| AMGC[1:0] | Mode |
|-----------|-----------------------------------|
| 00 | User programmable GC |
| 01 | AC no clipping 2.1 |
| 10 | AC limited clipping (10%) 2.1 |
| 11 | DRC night-time listening mode 2.1 |

7.8.2 Audio preset register 2 (addr 0x0C)

| D7 | D6 | D5 | D4 | D3 | D2 | D1 | D0 |
|-----|-----|-----|-----|-------|-------|-------|-------|
| XO3 | XO2 | XO1 | XO0 | AMAM2 | AMAM1 | AMAM0 | AMAME |
| 0 | 0 | 0 | 0 | 0 | 0 | 0 | 0 |

7.8.3 AM interference frequency switching

Table 57. AM interference frequency switching bits

| Bit | R/W | RST | Name | Description |
|-----|-----|-----|-------|---|
| 0 | R/W | 0 | AMAME | Audio preset AM enable 0: switching frequency determined by PWMS setting 1: switching frequency determined by AMAM settings |

Table 58. Audio preset AM switching frequency selection

| AMAM[2:0] | 48 kHz/96 kHz input fs | 44.1 kHz/88.2 kHz input fs |
|-----------|------------------------|----------------------------|
| 000 | 0.535 MHz - 0.720 MHz | 0.535 MHz - 0.670 MHz |
| 001 | 0.721 MHz - 0.900 MHz | 0.671 MHz - 0.800 MHz |
| 010 | 0.901 MHz - 1.100 MHz | 0.801 MHz - 1.000 MHz |
| 011 | 1.101 MHz - 1.300 MHz | 1.001 MHz - 1.180 MHz |
| 100 | 1.301 MHz - 1.480 MHz | 1.181 MHz - 1.340 MHz |
| 101 | 1.481 MHz - 1.600 MHz | 1.341 MHz - 1.500 MHz |
| 110 | 1.601 MHz - 1.700 MHz | 1.501 MHz - 1.700 MHz |

7.8.4 Bass management crossover

Table 59. Bass management crossover

| Bit | R/W | RST | Name | Description |
|-----|-----|-----|------|---|
| 4 | R/W | 0 | XO0 | Selects the bass-management crossover frequency. A 1st-order high-pass filter (channels 1 and 2) or a 2nd-order low-pass filter (channel 3) at the selected frequency is performed. |
| 5 | R/W | 0 | XO1 | |
| 6 | R/W | 0 | XO2 | |
| 7 | R/W | 0 | XO3 | |

Table 60. Bass management crossover frequency

| XO[3:0] | Crossover frequency |
|---------|---------------------|
| 0000 | User-defined |
| 0001 | 80 Hz |
| 0010 | 100 Hz |
| 0011 | 120 Hz |

Table 60. Bass management crossover frequency (continued)

| XO[3:0] | Crossover frequency |
|---------|---------------------|
| 0100 | 140 Hz |
| 0101 | 160 Hz |
| 0110 | 180 Hz |
| 0111 | 200 Hz |
| 1000 | 220 Hz |
| 1001 | 240 Hz |
| 1010 | 260 Hz |
| 1011 | 280 Hz |
| 1100 | 300 Hz |
| 1101 | 320 Hz |
| 1110 | 340 Hz |
| 1111 | 360 Hz |

7.9 Channel configuration registers (addr 0x0E - 0x10)

| D7 | D6 | D5 | D4 | D3 | D2 | D1 | D0 |
|-------|-------|-------|-------|------|-------|--------|-------|
| C1OM1 | C1OM0 | C1LS1 | C1LS0 | C1BO | C1VPB | C1EQBP | C1TCB |
| 0 | 0 | 0 | 0 | 0 | 0 | 0 | 0 |

| D7 | D6 | D5 | D4 | D3 | D2 | D1 | D0 |
|-------|-------|-------|-------|------|-------|--------|-------|
| C2OM1 | C2OM0 | C2LS1 | C2LS0 | C2BO | C2VPB | C2EQBP | C2TCB |
| 0 | 1 | 0 | 0 | 0 | 0 | 0 | 0 |

| D7 | D6 | D5 | D4 | D3 | D2 | D1 | D0 |
|-------|-------|-------|-------|------|-------|----------|----|
| C3OM1 | C3OM0 | C3LS1 | C3LS0 | C3BO | C3VPB | Reserved | |
| 1 | 0 | 0 | 0 | 0 | 0 | 0 | 0 |

7.9.1 Tone control bypass

Tone control (bass/treble) can be bypassed on a per channel basis for channels 1 and 2.

Table 61. Tone control bypass

| CxTCB | Mode |
|-------|--|
| 0 | Perform tone control on channel x - normal operation |
| 1 | Bypass tone control on channel x |

7.9.2 EQ bypass

EQ control can be bypassed on a per channel basis for channels 1 and 2. If EQ control is bypassed on a given channel the prescale and all filters (high-pass, biquads, de-emphasis, bass, treble in any combination) are bypassed for that channel.

Table 62. EQ bypass

| CxEQBP | Mode |
|--------|--|
| 0 | Perform EQ on channel x - normal operation |
| 1 | Bypass EQ on channel x |

7.9.3 Volume bypass

Each channel contains an individual channel volume bypass. If a particular channel has volume bypassed via the CxVBP = 1 register then only the channel volume setting for that particular channel affects the volume setting, the master volume setting will not affect that channel.

7.9.4 Binary output enable registers

Each individual channel output can be set to output a binary PWM stream. In this mode output A of a channel is considered the positive output and output B is negative inverse.

Table 63. Binary output enable registers

| CxBO | Mode |
|------|---------------------------------------|
| 0 | FFX 3-state output - normal operation |
| 1 | Binary output |

7.9.5 Limiter select

Limiter selection can be made on a per-channel basis according to the channel limiter select bits.

Table 64. Channel limiter mapping as a function of CxLS bits

| CxLS[1:0] | Channel limiter mapping |
|-----------|---------------------------------|
| 00 | Channel has limiting disabled |
| 01 | Channel is mapped to limiter #1 |
| 10 | Channel is mapped to limiter #2 |

7.9.6 Output mapping

Output mapping can be performed on a per channel basis according to the CxOM channel output mapping bits. Each input into the output configuration engine can receive data from any of the three processing channel outputs.

Table 65. Channel output mapping as a function of CxOM bits

| CxOM[1:0] | Channel x output source from |
|-----------|------------------------------|
| 00 | Channel1 |
| 01 | Channel 2 |
| 10 | Channel 3 |

7.10 Tone control register (addr 0x11)

| | | | | | | | |
|------|------|------|------|------|------|------|------|
| D7 | D6 | D5 | D4 | D3 | D2 | D1 | D0 |
| TTC3 | TTC2 | TTC1 | TTC0 | BTC3 | BTC2 | BTC1 | BTC0 |
| 0 | 1 | 1 | 1 | 0 | 1 | 1 | 1 |

7.10.1 Tone control

Table 66. Tone control boost/cut as a function of BTC and TTC bits

| BTC[3:0]/TTC[3:0] | Boost/Cut |
|-------------------|-----------|
| 0000 | -12 dB |
| 0001 | -12 dB |
| ... | ... |
| 0111 | -4 dB |
| 0110 | -2 dB |
| 0111 | 0 dB |
| 1000 | +2 dB |
| 1001 | +4 dB |
| ... | ... |
| 1101 | +12 dB |
| 1110 | +12 dB |
| 1111 | +12 dB |

7.11 Dynamic control registers (addr 0x12 - 0x15)

7.11.1 Limiter 1 attack/release rate

| | | | | | | | |
|------|------|------|------|------|------|------|------|
| D7 | D6 | D5 | D4 | D3 | D2 | D1 | D0 |
| L1A3 | L1A2 | L1A1 | L1A0 | L1R3 | L1R2 | L1R1 | L1R0 |
| 0 | 1 | 1 | 0 | 1 | 0 | 1 | 0 |

7.11.2 Limiter 1 attack/release threshold

| | | | | | | | |
|-------|-------|-------|-------|-------|-------|-------|-------|
| D7 | D6 | D5 | D4 | D3 | D2 | D1 | D0 |
| L1AT3 | L1AT2 | L1AT1 | L1AT0 | L1RT3 | L1RT2 | L1RT1 | L1RT0 |
| 0 | 1 | 1 | 0 | 1 | 0 | 0 | 1 |

7.11.3 Limiter 2 attack/release rate

| | | | | | | | |
|------|------|------|------|------|------|------|------|
| D7 | D6 | D5 | D4 | D3 | D2 | D1 | D0 |
| L2A3 | L2A2 | L2A1 | L2A0 | L2R3 | L2R2 | L2R1 | L2R0 |
| 0 | 1 | 1 | 0 | 1 | 0 | 1 | 0 |

7.11.4 Limiter 2 attack/release threshold

| D7 | D6 | D5 | D4 | D3 | D2 | D1 | D0 |
|-------|-------|-------|-------|-------|-------|-------|-------|
| L2AT3 | L2AT2 | L2AT1 | L2AT0 | L2RT3 | L2RT2 | L2RT1 | L2RT0 |
| 0 | 1 | 1 | 0 | 1 | 0 | 0 | 1 |

The STA339BW includes two independent limiter blocks. The purpose of the limiters is to automatically reduce the dynamic range of a recording to prevent the outputs from clipping in anti-clipping mode or to actively reduce the dynamic range for a better listening environment such as a night-time listening mode which is often needed for DVDs. The two modes are selected via the DRC bit in [Configuration register E \(addr 0x04\) on page 37](#). Each channel can be mapped to either limiter or not mapped, meaning that channel will clip when 0 dBfs is exceeded. Each limiter looks at the present value of each channel that is mapped to it, selects the maximum absolute value of all these channels, performs the limiting algorithm on that value, and then if needed adjusts the gain of the mapped channels in unison.

The limiter attack thresholds are determined by the LxAT registers if EATHx[7] bits are set to 0 else the thresholds are determined by EATHx[6:0]. It is recommended in anti-clipping mode to set this to 0 dBfs, which corresponds to the maximum unclipped output power of a FFX amplifier. Since gain can be added digitally within the STA339BW it is possible to exceed 0 dBfs or any other LxAT setting, when this occurs, the limiter, when active, automatically starts reducing the gain. The rate at which the gain is reduced when the attack threshold is exceeded is dependent upon the attack rate register setting for that limiter. Gain reduction occurs on a peak-detect algorithm. Setting EATHx[7] bits to 1 selects the anti-clipping mode.

The limiter release thresholds are determined by the LxRT registers if ERTx[7] bits are set to 0 else the thresholds are determined by ERTx[6:0]. Settings to 1 ERTx[7] bits the anti-clipping mode is selected automatically. The release of limiter, when the gain is again increased, is dependent on a RMS-detect algorithm. The output of the volume/limiter block is passed through a RMS filter. The output of this filter is compared to the release threshold, determined by the Release Threshold register. When the RMS filter output falls below the release threshold, the gain is again increased at a rate dependent upon the Release Rate register. The gain can never be increased past its set value and, therefore, the release only occurs if the limiter has already reduced the gain. The release threshold value can be used to set what is effectively a minimum dynamic range, this is helpful as over-limiting can reduce the dynamic range to virtually zero and cause program material to sound "lifeless".

In AC mode, the attack and release thresholds are set relative to full-scale. In DRC mode, the attack threshold is set relative to the maximum volume setting of the channels mapped to that limiter and the release threshold is set relative to the maximum volume setting plus the attack threshold.

Figure 20. Basic limiter and volume flow diagram

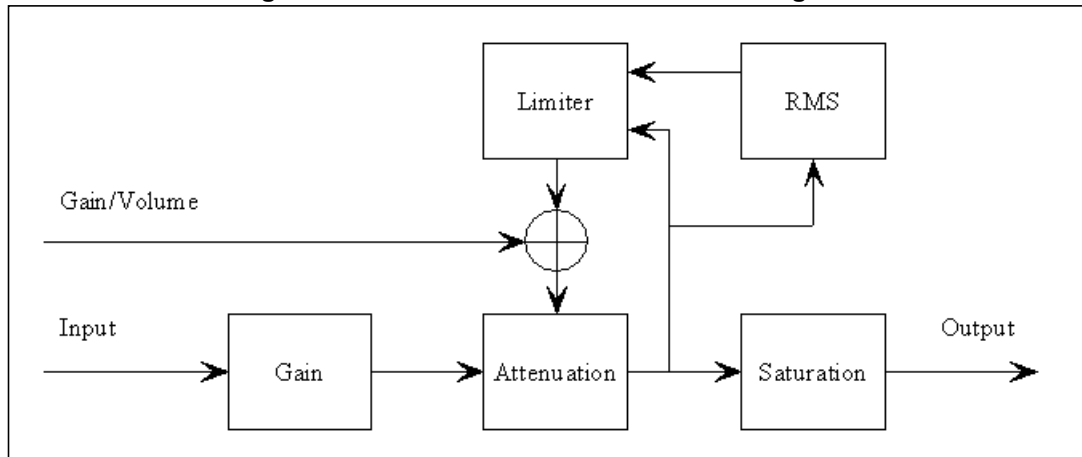

Table 67. Limiter attack rate as a function of LxA bits

| LxA[3:0] | Attack Rate dB/ms | |
|----------|-------------------|-------------------|
| 0000 | 3.1584 | Fast ↓ Slow |
| 0001 | 2.7072 | |
| 0010 | 2.2560 | |
| 0011 | 1.8048 | |
| 0100 | 1.3536 | |
| 0101 | 0.9024 | |
| 0110 | 0.4512 | |
| 0111 | 0.2256 | |
| 1000 | 0.1504 | |
| 1001 | 0.1123 | |
| 1010 | 0.0902 | |
| 1011 | 0.0752 | |
| 1100 | 0.0645 | |
| 1101 | 0.0564 | |
| 1110 | 0.0501 | |
| 1111 | 0.0451 | |

Table 68. Limiter release rate as a function of LxR bits

| LxR[3:0] | Release Rate dB/ms | |
|----------|--------------------|-------------------|
| 0000 | 0.5116 | Fast ↓ Slow |
| 0001 | 0.1370 | |
| 0010 | 0.0744 | |
| 0011 | 0.0499 | |
| 0100 | 0.0360 | |
| 0101 | 0.0299 | |
| 0110 | 0.0264 | |
| 0111 | 0.0208 | |
| 1000 | 0.0198 | |
| 1001 | 0.0172 | |
| 1010 | 0.0147 | |
| 1011 | 0.0137 | |
| 1100 | 0.0134 | |
| 1101 | 0.0117 | |
| 1110 | 0.0110 | |
| 1111 | 0.0104 | |

Anti-clipping mode

Table 69. Limiter attack threshold as a function of LxAT bits (AC mode)

| LxAT[3:0] | AC (dB relative to fs) |
|-----------|------------------------|
| 0000 | -12 |
| 0001 | -10 |
| 0010 | -8 |
| 0011 | -6 |
| 0100 | -4 |
| 0101 | -2 |
| 0110 | 0 |
| 0111 | +2 |
| 1000 | +3 |
| 1001 | +4 |
| 1010 | +5 |
| 1011 | +6 |
| 1100 | +7 |
| 1101 | +8 |
| 1110 | +9 |
| 1111 | +10 |

Table 70. Limiter release threshold as a function of LxRT bits (AC mode)

| LxRT[3:0] | AC (dB relative to fs) |
|-----------|------------------------|
| 0000 | $-\infty$ |
| 0001 | -29 dB |
| 0010 | -20 dB |
| 0011 | -16 dB |
| 0100 | -14 dB |
| 0101 | -12 dB |
| 0110 | -10 dB |
| 0111 | -8 dB |
| 1000 | -7 dB |
| 1001 | -6 dB |
| 1010 | -5 dB |
| 1011 | -4 dB |
| 1100 | -3 dB |
| 1101 | -2 dB |
| 1110 | -1 dB |
| 1111 | -0 dB |

Dynamic range compression mode

Table 71. Limiter attack threshold as a function of LxAT bits (DRC mode)

| LxAT[3:0] | DRC (dB relative to Volume) |
|-----------|-----------------------------|
| 0000 | -31 |
| 0001 | -29 |
| 0010 | -27 |
| 0011 | -25 |
| 0100 | -23 |
| 0101 | -21 |
| 0110 | -19 |
| 0111 | -17 |
| 1000 | -16 |
| 1001 | -15 |
| 1010 | -14 |
| 1011 | -13 |
| 1100 | -12 |
| 1101 | -10 |
| 1110 | -7 |
| 1111 | -4 |

Table 72. Limiter release threshold as a function of LxRT bits (DRC mode)

| LxRT[3:0] | DRC (db relative to Volume + LxAT) |
|-----------|------------------------------------|
| 0000 | -∞ |
| 0001 | -38 dB |
| 0010 | -36 dB |
| 0011 | -33 dB |
| 0100 | -31 dB |
| 0101 | -30 dB |
| 0110 | -28 dB |
| 0111 | -26 dB |
| 1000 | -24 dB |
| 1001 | -22 dB |
| 1010 | -20 dB |
| 1011 | -18 dB |
| 1100 | -15 dB |
| 1101 | -12 dB |
| 1110 | -9 dB |
| 1111 | -6 dB |

7.11.5 Limiter 1 Extended attack threshold (addr 0x32)

| D7 | D6 | D5 | D4 | D3 | D2 | D1 | D0 |
|---------|----------|----------|----------|----------|----------|----------|----------|
| EATHEN1 | EATH1[6] | EATH1[5] | EATH1[4] | EATH1[3] | EATH1[2] | EATH1[1] | EATH1[0] |
| TBD | TBD | TBD | TBD | TBD | TBD | TBD | TBD |

The extended attack threshold value is determined as follows:

$$\text{attack threshold} = -12 + \text{EATH1} / 4$$

7.11.6 Limiter 1 Extended release threshold (addr 0x33)

| D7 | D6 | D5 | D4 | D3 | D2 | D1 | D0 |
|---------|----------|----------|----------|----------|----------|----------|----------|
| ERTHEN1 | ERTH1[6] | ERTH1[5] | ERTH1[4] | ERTH1[3] | ERTH1[2] | ERTH1[1] | ERTH1[0] |
| TBD | TBD | TBD | TBD | TBD | TBD | TBD | TBD |

The extended release threshold value is determined as follows:

$$\text{release threshold} = -12 + \text{ERTH1} / 4$$

7.11.7 Limiter 2 Extended attack threshold (addr 0x34)

| D7 | D6 | D5 | D4 | D3 | D2 | D1 | D0 |
|---------|----------|----------|----------|----------|----------|----------|----------|
| EATHEN2 | EATH2[6] | EATH2[5] | EATH2[4] | EATH2[3] | EATH2[2] | EATH2[1] | EATH2[0] |
| TBD | TBD | TBD | TBD | TBD | TBD | TBD | TBD |

The extended attack threshold value is determined as follows:

$$\text{attack threshold} = -12 + \text{EATH2} / 4$$

7.11.8 Limiter 2 Extended release threshold (addr 0x35)

| D7 | D6 | D5 | D4 | D3 | D2 | D1 | D0 |
|---------|----------|----------|----------|----------|----------|----------|----------|
| ERTHEN2 | ERTH2[6] | ERTH2[5] | ERTH2[4] | ERTH2[3] | ERTH2[2] | ERTH2[1] | ERTH2[0] |
| TBD | TBD | TBD | TBD | TBD | TBD | TBD | TBD |

The extended release threshold value is determined as follows:

$$\text{release threshold} = -12 + \text{ERTH2} / 4$$

Note: Attack/release threshold step is 0.125 dB in the range -12 dB and 0 dB.

7.12 User-defined coefficient control registers (addr 0x16 - 0x26)

7.12.1 Coefficient address register

| D7 | D6 | D5 | D4 | D3 | D2 | D1 | D0 |
|----------|----|------|------|------|------|------|------|
| Reserved | | CFA5 | CFA4 | CFA3 | CFA2 | CFA1 | CFA0 |
| 0 | | 0 | 0 | 0 | 0 | 0 | 0 |

7.12.2 Coefficient b1 data register bits 23:16

| D7 | D6 | D5 | D4 | D3 | D2 | D1 | D0 |
|-------|-------|-------|-------|-------|-------|-------|-------|
| C1B23 | C1B22 | C1B21 | C1B20 | C1B19 | C1B18 | C1B17 | C1B16 |
| 0 | 0 | 0 | 0 | 0 | 0 | 0 | 0 |

7.12.3 Coefficient b1 data register bits 15:8

| D7 | D6 | D5 | D4 | D3 | D2 | D1 | D0 |
|-------|-------|-------|-------|-------|-------|------|------|
| C1B15 | C1B14 | C1B13 | C1B12 | C1B11 | C1B10 | C1B9 | C1B8 |
| 0 | 0 | 0 | 0 | 0 | 0 | 0 | 0 |

7.12.4 Coefficient b1 data register bits 7:0

| D7 | D6 | D5 | D4 | D3 | D2 | D1 | D0 |
|------|------|------|------|------|------|------|------|
| C1B7 | C1B6 | C1B5 | C1B4 | C1B3 | C1B2 | C1B1 | C1B0 |
| 0 | 0 | 0 | 0 | 0 | 0 | 0 | 0 |

7.12.5 Coefficient b2 data register bits 23:16

| D7 | D6 | D5 | D4 | D3 | D2 | D1 | D0 |
|-------|-------|-------|-------|-------|-------|-------|-------|
| C2B23 | C2B22 | C2B21 | C2B20 | C2B19 | C2B18 | C2B17 | C2B16 |
| 0 | 0 | 0 | 0 | 0 | 0 | 0 | 0 |

7.12.6 Coefficient b2 data register bits 15:8

| D7 | D6 | D5 | D4 | D3 | D2 | D1 | D0 |
|-------|-------|-------|-------|-------|-------|------|------|
| C2B15 | C2B14 | C2B13 | C2B12 | C2B11 | C2B10 | C2B9 | C2B8 |
| 0 | 0 | 0 | 0 | 0 | 0 | 0 | 0 |

7.12.7 Coefficient b2 data register bits 7:0

| D7 | D6 | D5 | D4 | D3 | D2 | D1 | D0 |
|------|------|------|------|------|------|------|------|
| C2B7 | C2B6 | C2B5 | C2B4 | C2B3 | C2B2 | C2B1 | C2B0 |
| 0 | 0 | 0 | 0 | 0 | 0 | 0 | 0 |

7.12.8 Coefficient a1 data register bits 23:16

| D7 | D6 | D5 | D4 | D3 | D2 | D1 | D0 |
|-------|-------|-------|-------|-------|-------|-------|-------|
| C1B23 | C1B22 | C1B21 | C1B20 | C1B19 | C1B18 | C1B17 | C1B16 |
| 0 | 0 | 0 | 0 | 0 | 0 | 0 | 0 |

7.12.9 Coefficient a1 data register bits 15:8

| D7 | D6 | D5 | D4 | D3 | D2 | D1 | D0 |
|-------|-------|-------|-------|-------|-------|------|------|
| C3B15 | C3B14 | C3B13 | C3B12 | C3B11 | C3B10 | C3B9 | C3B8 |
| 0 | 0 | 0 | 0 | 0 | 0 | 0 | 0 |

7.12.10 Coefficient a1 data register bits 7:0

| D7 | D6 | D5 | D4 | D3 | D2 | D1 | D0 |
|------|------|------|------|------|------|------|------|
| C3B7 | C3B6 | C3B5 | C3B4 | C3B3 | C3B2 | C3B1 | C3B0 |
| 0 | 0 | 0 | 0 | 0 | 0 | 0 | 0 |

7.12.11 Coefficient a2 data register bits 23:16

| D7 | D6 | D5 | D4 | D3 | D2 | D1 | D0 |
|-------|-------|-------|-------|-------|-------|-------|-------|
| C4B23 | C4B22 | C4B21 | C4B20 | C4B19 | C4B18 | C4B17 | C4B16 |
| 0 | 0 | 0 | 0 | 0 | 0 | 0 | 0 |

7.12.12 Coefficient a2 data register bits 15:8

| D7 | D6 | D5 | D4 | D3 | D2 | D1 | D0 |
|-------|-------|-------|-------|-------|-------|------|------|
| C4B15 | C4B14 | C4B13 | C4B12 | C4B11 | C4B10 | C4B9 | C4B8 |
| 0 | 0 | 0 | 0 | 0 | 0 | 0 | 0 |

7.12.13 Coefficient a2 data register bits 7:0

| D7 | D6 | D5 | D4 | D3 | D2 | D1 | D0 |
|------|------|------|------|------|------|------|------|
| C4B7 | C4B6 | C4B5 | C4B4 | C4B3 | C4B2 | C4B1 | C4B0 |
| 0 | 0 | 0 | 0 | 0 | 0 | 0 | 0 |

7.12.14 Coefficient b0 data register bits 23:16

| D7 | D6 | D5 | D4 | D3 | D2 | D1 | D0 |
|-------|-------|-------|-------|-------|-------|-------|-------|
| C5B23 | C5B22 | C5B21 | C5B20 | C5B19 | C5B18 | C5B17 | C5B16 |
| 0 | 0 | 0 | 0 | 0 | 0 | 0 | 0 |

7.12.15 Coefficient b0 data register bits 15:8

| D7 | D6 | D5 | D4 | D3 | D2 | D1 | D0 |
|-------|-------|-------|-------|-------|-------|------|------|
| C5B15 | C5B14 | C5B13 | C5B12 | C5B11 | C5B10 | C5B9 | C5B8 |
| 0 | 0 | 0 | 0 | 0 | 0 | 0 | 0 |

7.12.16 Coefficient b0 data register bits 7:0

| D7 | D6 | D5 | D4 | D3 | D2 | D1 | D0 |
|------|------|------|------|------|------|------|------|
| C5B7 | C5B6 | C5B5 | C5B4 | C5B3 | C5B2 | C5B1 | C5B0 |
| 0 | 0 | 0 | 0 | 0 | 0 | 0 | 0 |

7.12.17 Coefficient write/read control register

| D7 | D6 | D5 | D4 | D3 | D2 | D1 | D0 |
|----------|----|----|----|----|----|----|----|
| Reserved | | | | RA | R1 | WA | W1 |
| 0 | | | | 0 | 0 | 0 | 0 |

Coefficients for user-defined EQ, mixing, scaling, and bass management are handled internally in the STA339BW via RAM. Access to this RAM is available to the user via an I²C register interface. A collection of I²C registers are dedicated to this function. One contains a coefficient base address, five sets of three store the values of the 24-bit coefficients to be written or that were read, and one contains bits used to control the write/read of the coefficient(s) to/from RAM.

Three different RAM banks are embedded in STA339BW. The three banks are managed in paging mode using EQCFG register bits. They can be used to store different EQ settings. For speaker frequency compensation, a sampling frequency independent EQ must be implemented. Computing three different coefficients set for 32 kHz, 44.1kHz, 48 kHz and downloading them into the three RAM banks, it is possible to select the suitable RAM block depending from the incoming frequency with a simple I²C write operation on register 0x31.

For example, in case of different input sources (different sampling rates), the three different sets of coefficients can be downloaded once at the start up, and during the normal play it is possible to switch among the three RAM blocks allowing a faster operation, without any additional download from the microcontroller.

To write the coefficients in a particular RAM bank, this bank must be selected first writing bit 0 and bit 1 in register 0x31. Then the write procedure below can be used.

Note that as soon as a RAM bank is selected, the EQ settings are automatically switched to the coefficients stored in the active RAM block.

Note: The read write operation on RAM coefficients works only if RLCKI (pin29) is switching and stable (ref. Table 9, tLRJT timing) and PLL must be locked (ref bit D7 reg 0x2D).

Reading a coefficient from RAM

1. Select the RAM block with register 0x31 bit1, bit0.
2. Write 6 bits of address to I²C register 0x16.
3. Write 1 to R1 bit in I²C address 0x26.
4. Read top 8 bits of coefficient in I²C address 0x17.
5. Read middle 8 bits of coefficient in I²C address 0x18.
6. Read bottom 8 bits of coefficient in I²C address 0x19.

Reading a set of coefficients from RAM

1. Select the RAM block with register 0x31 bit1, bit0.
2. Write 6 bits of address to I²C register 0x16.
3. Write 1 to RA bit in I²C address 0x26.
4. Read top 8 bits of coefficient in I²C address 0x17.
5. Read middle 8 bits of coefficient in I²C address 0x18.
6. Read bottom 8 bits of coefficient in I²C address 0x19.
7. Read top 8 bits of coefficient b2 in I²C address 0x1A.
8. Read middle 8 bits of coefficient b2 in I²C address 0x1B.
9. Read bottom 8 bits of coefficient b2 in I²C address 0x1C.
10. Read top 8 bits of coefficient a1 in I²C address 0x1D.
11. Read middle 8 bits of coefficient a1 in I²C address 0x1E.
12. Read bottom 8 bits of coefficient a1 in I²C address 0x1F.
13. Read top 8 bits of coefficient a2 in I²C address 0x20.
14. Read middle 8 bits of coefficient a2 in I²C address 0x21.
15. Read bottom 8 bits of coefficient a2 in I²C address 0x22.
16. Read top 8 bits of coefficient b0 in I²C address 0x23.
17. Read middle 8 bits of coefficient b0 in I²C address 0x24.
18. Read bottom 8 bits of coefficient b0 in I²C address 0x25.

Writing a single coefficient to RAM

1. Select the RAM block with register 0x31 bit1, bit0.
2. Write 6 bits of address to I²C register 0x16.
3. Write top 8 bits of coefficient in I²C address 0x17.
4. Write middle 8 bits of coefficient in I²C address 0x18.
5. Write bottom 8 bits of coefficient in I²C address 0x19.
6. Write 1 to W1 bit in I²C address 0x26.

Writing a set of coefficients to RAM

1. Select the RAM block with register 0x31 bit1, bit0.
2. Write 6 bits of starting address to I²C register 0x16.
3. Write top 8 bits of coefficient b1 in I²C address 0x17.
4. Write middle 8 bits of coefficient b1 in I²C address 0x18.
5. Write bottom 8 bits of coefficient b1 in I²C address 0x19.
6. Write top 8 bits of coefficient b2 in I²C address 0x1A.
7. Write middle 8 bits of coefficient b2 in I²C address 0x1B.
8. Write bottom 8 bits of coefficient b2 in I²C address 0x1C.
9. Write top 8 bits of coefficient a1 in I²C address 0x1D.
10. Write middle 8 bits of coefficient a1 in I²C address 0x1E.
11. Write bottom 8 bits of coefficient a1 in I²C address 0x1F.
12. Write top 8 bits of coefficient a2 in I²C address 0x20.
13. Write middle 8 bits of coefficient a2 in I²C address 0x21.
14. Write bottom 8 bits of coefficient a2 in I²C address 0x22.
15. Write top 8 bits of coefficient b0 in I²C address 0x23.
16. Write middle 8 bits of coefficient b0 in I²C address 0x24.
17. Write bottom 8 bits of coefficient b0 in I²C address 0x25.
18. Write 1 to WA bit in I²C address 0x26.

The mechanism for writing a set of coefficients to RAM provides a method of updating the five coefficients corresponding to a given biquad (filter) simultaneously to avoid possible unpleasant acoustic side-effects. When using this technique, the 6-bit address specifies the address of the biquad b1 coefficient (for example, 0, 5, 10, 20, 35 decimal), and the STA339BW generates the RAM addresses as offsets from this base value to write the complete set of coefficient data.

7.12.18 User-defined EQ

The STA339BW can be programmed for four EQ filters (biquads) per each of the two input channels. The biquads use the following equation:

$$Y[n] = 2 * (b_0 / 2) * X[n] + 2 * (b_1 / 2) * X[n-1] + b_2 * X[n-2] - 2 * (a_1 / 2) * Y[n-1] - a_2 * Y[n-2]$$

$$= b_0 * X[n] + b_1 * X[n-1] + b_2 * X[n-2] - a_1 * Y[n-1] - a_2 * Y[n-2]$$

where $Y[n]$ represents the output and $X[n]$ represents the input. Multipliers are 24-bit signed fractional multipliers, with coefficient values in the range of 0x800000 (-1) to 0x7FFFFFFF (0.9999998808).

Coefficients stored in the user defined coefficient RAM are referenced in the following manner:

$$CxHy0 = b_1 / 2$$

$$CxHy1 = b_2$$

$$CxHy2 = -a_1 / 2$$

$$CxHy3 = -a_2$$

$$CxHy4 = b_0 / 2$$

where x represents the channel and the y the biquad number. For example, C2H41 is the b_2 coefficient in the fourth biquad for channel 2.

Additionally, the STA339BW can be programmed for a high-pass filter (processing channels 1 and 2) and a low-pass filter (processing channel 3) to be used for bass-management crossover when the XO setting is 000 (user-defined). Both of these filters when defined by the user (rather than using the preset crossover filters) are second order filters that use the biquad equation given above. They are loaded into the C12H0-4 and C3Hy0-4 areas of RAM noted in [Table 73](#).

By default, all user-defined filters are pass-through where all coefficients are set to 0, except the $b_0/2$ coefficient which is set to 0x400000 (representing 0.5)

7.12.19 Prescale

The STA339BW provides a multiplication for each input channel for the purpose of scaling the input prior to EQ. This pre-EQ scaling is accomplished by using a 24-bit signed fractional multiplier, with 0x800000 = -1 and 0x7FFFFFFF = 0.9999998808. The scale factor for this multiplication is loaded into RAM using the same I²C registers as the biquad coefficients and the bass management. All channels can use the channel-1 prescale factor by setting the Biquad link bit. By default, all prescale factors are set to 0x7FFFFFFF.

7.12.20 Postscale

The STA339BW provides one additional multiplication after the last interpolation stage and the distortion compensation on each channel. This postscaling is accomplished by using a 24-bit signed fractional multiplier, with 0x800000 = -1 and 0x7FFFFFFF = 0.9999998808. The scale factor for this multiply is loaded into RAM using the same I²C registers as the biquad coefficients and the bass management. This postscale factor can be used in conjunction with an ADC equipped microcontroller to perform power-supply error correction. All channels can use the channel-1 postscale factor by setting the postscale link bit. By default, all postscale factors are set to 0x7FFFFFFF. When line output is being used, channel-3 postscale will affect both channels 3 and 4.

7.12.21 Overcurrent postscale

The STA339BW provides a simple mechanism for reacting to overcurrent detection in the power block. When the *ocwarn* input is asserted, the overcurrent postscale value is used in place of the normal postscale value to provide output attenuation on all channels. The default setting provides 3 dB of output attenuation when *ocwarn* is asserted.

The amount of attenuation to be applied in this situation can be adjusted by modifying the Overcurrent postscale value. As with the normal postscale, this scaling value is a 24-bit signed fractional multiplier, with 0x800000 = -1 and 0x7FFFFFFF = 0.9999998808. By default, the overcurrent postscale factor is set to 0x5A9DF7. Once the overcurrent attenuation is applied, it remains until the device is reset.

Table 73. RAM block for biquads, mixing, scaling and bass management

| Index (decimal) | Index (hex) | RAM block setting | Coefficient | Default |
|-----------------|-------------|--|-------------|------------|
| 0 | 0x00 | Channel 1 - Biquad 1 | C1H10(b1/2) | 0x000000 |
| 1 | 0x01 | | C1H11(b2) | 0x000000 |
| 2 | 0x02 | | C1H12(a1/2) | 0x000000 |
| 3 | 0x03 | | C1H13(a2) | 0x000000 |
| 4 | 0x04 | | C1H14(b0/2) | 0x400000 |
| 5 | 0x05 | Channel 1 - Biquad 2 | C1H20 | 0x000000 |
| ... | ... | ... | ... | ... |
| 19 | 0x13 | Channel 1 - Biquad 4 | C1H44 | 0x400000 |
| 20 | 0x14 | Channel 2 - Biquad 1 | C2H10 | 0x000000 |
| 21 | 0x15 | | C2H11 | 0x000000 |
| ... | ... | ... | ... | ... |
| 39 | 0x27 | Channel 2 - Biquad 4 | C2H44 | 0x400000 |
| 40 | 0x28 | Channel 1/2 - Biquad 5 for XO = 000 High-pass 2 nd order filter for XO≠000 | C12H0(b1/2) | 0x000000 |
| 41 | 0x29 | | C12H1(b2) | 0x000000 |
| 42 | 0x2A | | C12H2(a1/2) | 0x000000 |
| 43 | 0x2B | | C12H3(a2) | 0x000000 |
| 44 | 0x2C | | C12H4(b0/2) | 0x400000 |
| 45 | 0x2D | Channel 3 - Biquad for XO = 000 Low-pass 2 nd order filter for XO≠000 | C3H0(b1/2) | 0x000000 |
| 46 | 0x2E | | C3H1(b2) | 0x000000 |
| 47 | 0x2F | | C3H2(a1/2) | 0x000000 |
| 48 | 0x30 | | C3H3(a2) | 0x000000 |
| 49 | 0x31 | | C3H4(b0/2) | 0x400000 |
| 50 | 0x32 | Channel 1 - Prescale | C1PreS | 0x7FFFFFFF |
| 51 | 0x33 | Channel 2 - Prescale | C2PreS | 0x7FFFFFFF |
| 52 | 0x34 | Channel 1 - Postscale | C1PstS | 0x7FFFFFFF |
| 53 | 0x35 | Channel 2 - Postscale | C2PstS | 0x7FFFFFFF |
| 54 | 0x36 | Channel 3 - Postscale | C3PstS | 0x7FFFFFFF |

Table 73. RAM block for biquads, mixing, scaling and bass management (continued)

| Index (decimal) | Index (hex) | RAM block setting | Coefficient | Default |
|-----------------|-------------|-------------------|-------------|------------|
| 55 | 0x37 | TWARN/OC - Limit | TWOCL | 0x5A9DF7 |
| 56 | 0x38 | Channel 1 - Mix 1 | C1MX1 | 0x7FFFFFFF |
| 57 | 0x39 | Channel 1 - Mix 2 | C1MX2 | 0x000000 |
| 58 | 0x3A | Channel 2 - Mix 1 | C2MX1 | 0x000000 |
| 59 | 0x3B | Channel 2 - Mix 2 | C2MX2 | 0x7FFFFFFF |
| 60 | 0x3C | Channel 3 - Mix 1 | C3MX1 | 0x400000 |
| 61 | 0x3D | Channel 3 - Mix 2 | C3MX2 | 0x400000 |
| 62 | 0x3E | Unused | - | - |
| 63 | 0x3F | Unused | - | - |

7.13 Variable max power correction registers (addr 0x27 - 0x28)

| D7 | D6 | D5 | D4 | D3 | D2 | D1 | D0 |
|--------|--------|--------|--------|--------|--------|-------|-------|
| MPCC15 | MPCC14 | MPCC13 | MPCC12 | MPCC11 | MPCC10 | MPCC9 | MPCC8 |
| 0 | 0 | 0 | 1 | 1 | 0 | 1 | 0 |

| D7 | D6 | D5 | D4 | D3 | D2 | D1 | D0 |
|-------|-------|-------|-------|-------|-------|-------|-------|
| MPCC7 | MPCC6 | MPCC5 | MPCC4 | MPCC3 | MPCC2 | MPCC1 | MPCC0 |
| 1 | 1 | 0 | 0 | 0 | 0 | 0 | 0 |

MPCC bits determine the 16 MSBs of the MPC compensation coefficient. This coefficient is used in place of the default coefficient when MPCV = 1.

7.14 Variable distortion compensation registers (addr 0x29 - 0x2A)

| D7 | D6 | D5 | D4 | D3 | D2 | D1 | D0 |
|-------|-------|-------|-------|-------|-------|------|------|
| DCC15 | DCC14 | DCC13 | DCC12 | DCC11 | DCC10 | DCC9 | DCC8 |
| 1 | 1 | 1 | 1 | 0 | 0 | 1 | 1 |

| D7 | D6 | D5 | D4 | D3 | D2 | D1 | D0 |
|------|------|------|------|------|------|------|------|
| DCC7 | DCC6 | DCC5 | DCC4 | DCC3 | DCC2 | DCC1 | DCC0 |
| 0 | 0 | 1 | 1 | 0 | 0 | 1 | 1 |

DCC bits determine the 16 MSBs of the Distortion compensation coefficient. This coefficient is used in place of the default coefficient when DCCV = 1.

7.15 Fault detect recovery constant registers (addr 0x2B - 0x2C)

| | | | | | | | |
|--------|--------|--------|--------|--------|--------|-------|-------|
| D7 | D6 | D5 | D4 | D3 | D2 | D1 | D0 |
| FDCR15 | FDCR14 | FDCR13 | FDCR12 | FDCR11 | FDCR10 | FDCR9 | FDCR8 |
| 0 | 0 | 0 | 0 | 0 | 0 | 0 | 0 |

| | | | | | | | |
|-------|-------|-------|-------|-------|-------|-------|-------|
| D7 | D6 | D5 | D4 | D3 | D2 | D1 | D0 |
| FDCR7 | FDCR6 | FDCR5 | FDCR4 | FDCR3 | FDCR2 | FDCR1 | FDCR0 |
| 0 | 0 | 0 | 0 | 1 | 1 | 0 | 0 |

FDCR bits specify the 16-bit fault detect recovery time delay. When FAULT is asserted, the TRISTATE output is immediately asserted low and held low for the time period specified by this constant. A constant value of 0x0001 in this register is approximately 0.083 ms. The default value of 0x000C gives approximately 0.1 ms.

7.16 Device status register (addr 0x2D)

| | | | | | | | |
|-------|-------|---------|---------|---------|--------|--------|-------|
| D7 | D6 | D5 | D4 | D3 | D2 | D1 | D0 |
| PLLUL | FAULT | UVFAULT | OVFAULT | OCFAULT | OCWARN | TFAULT | TWARN |

This read-only register provides fault- and thermal-warning status information from the power control block. Logic value 1 for faults or warning means normal state. Logic 0 means a fault or warning has been detected on the power bridge. The PLLUL = 1 means that the PLL is not locked.

Table 74. Status register bits

| Bit | R/W | RST | Name | Description |
|-----|-----|-----|---------|--|
| 7 | R | - | PLLUL | 0: PLL locked 1: PLL not locked |
| 6 | R | - | FAULT | 0: fault detected on power bridge 1: normal operation |
| 5 | R | - | UVFAULT | 0: VCCxX internally detected 1: undervoltage threshold |
| 4 | R | - | OVFAULT | 0: VCCxX internally detected 1: overvoltage threshold |
| 3 | R | - | OCFAULT | 0: overcurrent fault detected |
| 2 | R | - | OCWARN | 0: overcurrent warning |
| 1 | R | - | TFAULT | 0: thermal fault, junction temperature over limit |
| 0 | R | - | TWARN | 0: thermal warning, junction temperature is close to fault condition |

7.17 EQ coefficients and DRC configuration register (addr 0x31)

| D7 | D6 | D5 | D4 | D3 | D2 | D1 | D0 |
|-----|----------|----|---------|---------|----------|--------|--------|
| XOB | Reserved | | AMGC[3] | AMGC[2] | Reserved | SEL[1] | SEL[0] |
| 0 | 0 | 0 | 0 | 0 | 0 | 0 | 0 |

Table 75. EQ RAM select

| SEL[1:0] | EQ RAM bank selected |
|----------|----------------------|
| 00/11 | Bank 0 activated |
| 01 | Bank 1 activated |
| 10 | Bank 2 activated |

Bits AMGC[3:2] change the behavior of the bits AMGC[1:0] as given in [Table 76](#) below.

Table 76. Anti-clipping and DRC preset

| AMGC[3:2] | Anti-clipping and DRC preset selected |
|-----------|--|
| 00 | DRC/Anti-clipping behavior described in Table 56 on page 48 (default). |
| 01 | DRC/Anti-clipping behavior is described in Table 77 below |
| 10/11 | Reserved, do not use |

When AMGC[3:2] = 01 then the bits 1:0 are defined as given here in [Table 77](#).

Table 77. Anti-clipping selection for AMGC[3:2] = 01

| AMGC[1:0] | Mode |
|-----------|--|
| 00 | AC0, stereo anticlippping 0 dB limiter |
| 01 | AC1, stereo anticlippping +1.25 dB limiter |
| 10 | AC2, stereo anticlippping +2 dB limiter |
| 11 | Reserved do not use |

AC0, AC1, AC2 settings are designed for the loudspeaker protection function, limiting at the minimum any audio artefacts introduced by typical anti-clipping/DRC algorithms. More detailed information is available in the applications notes “Configurable output power rate using STA335BW” and “STA335BWS vs STA335BW”.

Bit XOB can be used to bypass the crossover filters. Logic 1 means that the function is not active. In this case, high pass crossover filter works as a passthrough on the data path (b0 = 1, all the other coefficients at logic 0) while the low pass filter is configured to have zero signal on channel-3 data processing (all the coefficients are at logic 0).

7.18 Extended configuration register (addr 0x36)

| D7 | D6 | D5 | D4 | D3 | D2 | D1 | D0 |
|---------|---------|--------|------|------|-----|-----|-----|
| Mdrc[1] | Mdrc[0] | PS48DB | XAR1 | XAR2 | BQ5 | BQ6 | BQ7 |
| 0 | 0 | 0 | 0 | 0 | 0 | 0 | 0 |

Extended configuration register provides access to B²DRC and biquads 5, 6 and 7.

7.18.1 Dual-band DRC

The STA339BW provides a dual-band DRC (B²DRC) on the left- and right-channel data path, as depicted in *Figure 21*. Dual-band DRC is activated by setting MDRC[1:0] = 1x.

Figure 21. B²DRC scheme

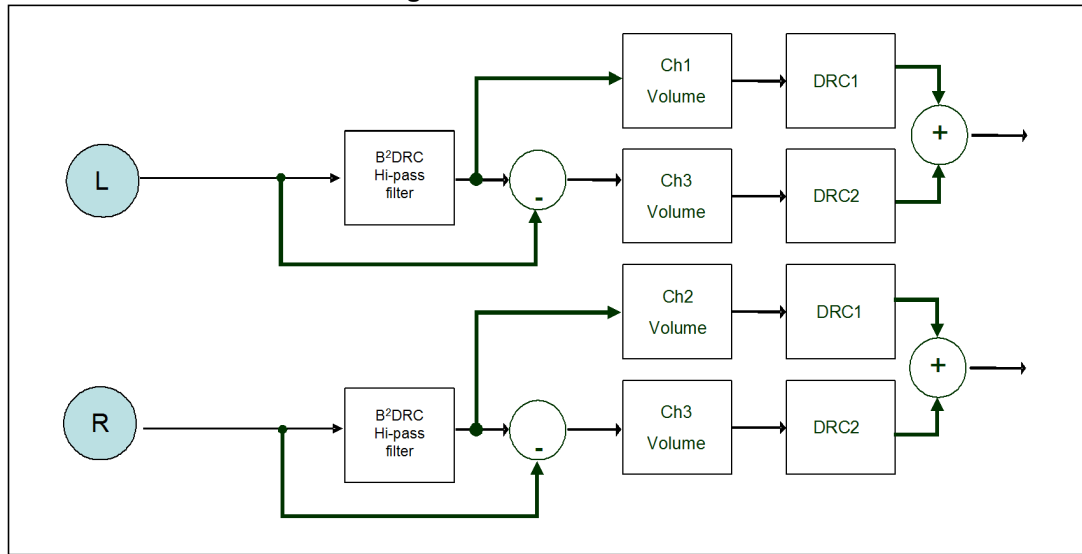

The low-frequency information (LFE) is extracted from the left and right channels by removing the high frequencies with a programmable Biquad filter, so that, using the original signal, the difference signal can be computed. Limiter 1 (DRC1) is then used to control the left and right high-frequency component amplitudes while limiter 2 (DRC2) is used to control the low-frequency components (see *Chapter 7.11*).

The cutoff frequency of the high-pass filters can be user defined, XO[3:0] = 0, or selected from the pre-defined values.

DRC1 and DRC2 are then used to independently limit the left- and right-channel high frequencies and the LFE-channel amplitude (see *Chapter 7.11*) as well as their volume control. Note that, in this configuration, the dedicated channel-3 volume control can actually be used as a bass boost enhancer as well (0.5 dB/step resolution).

The processed LFE channel is then recombined with the L and R channels in order to reconstruct the 2.0 output signal.

Sub band decomposition

The sub band decomposition for B²DRC can be configured specifying the cutoff frequency. The cut off frequency can be programmed in two ways, using XO bits in register 0x0C, or using “user programmable” mode (coefficients stored in RAM addresses 0x28 to 0x31).

For the user programmable mode, use the formulae below to compute the high pass filters:

$$\begin{aligned} b_0 &= (1 + \alpha) / 2 & a_0 &= 1 \\ b_1 &= -(1 + \alpha) / 2 & a_1 &= -\alpha \\ b_2 &= 0 & a_2 &= 0 \end{aligned}$$

where $\alpha = (1 - \sin(\omega_0)) / \cos(\omega_0)$, and ω_0 is the cutoff frequency.

A first-order filter is suggested to guarantee that for every ω_0 the corresponding low-pass filter obtained as difference (as shown in [Figure 21](#)) will have a symmetric (relative to HP filter) frequency response, and the corresponding recombination after the DRC has low ripple. Second-order filters can be used as well, but in this case the filter shape must be carefully chosen to provide good low pass response and minimum ripple recombination. For second-order is not possible to give a closed formula to get the best coefficients, but empirical adjustment should be done.

DRC settings

The DRC blocks used by B²DRC are the same as those described in [Chapter 7.11](#). B²DRC configure automatically the DRC blocks in anticlippping mode. Attack and release thresholds can be selected using registers 0x32, 0x33, 0x34, 0x35, while attack and release rates are configured by registers 0x12 and 0x14.

Band downmixing

The low-frequency band is down-mixed to the left and right channels at the B²DRC output. Channel volume can be used to weight the bands recombination to fine tune the overall frequency response.

7.18.2 EQ DRC mode

Setting MDRC = 01, it is possible to add a programmable biquad (the XO biquad at RAM addresses 0x28 to 0x2C is used for this purpose) to the Limiter/compressor measure path (side chain). Using EQDRC the peak detector input can be shaped in frequency using the programmable biquad. For example if a +2 dB bass boost is applied (using a low shelf filter for example), the effect is that the EQDRC out will limit bass frequencies to -2 dB below the selected attack treshold.

Generally speaking, if the biquad boosts frequency f with an amount of X dB, the level of a compressed sinusoid at the output will be $TH - X$, where TH is the selected attack threshold.

Note: EQDRC works only if the biquad frequency response magnitude is ≥ 0 dB for every frequency.

Figure 22. EQDRC scheme

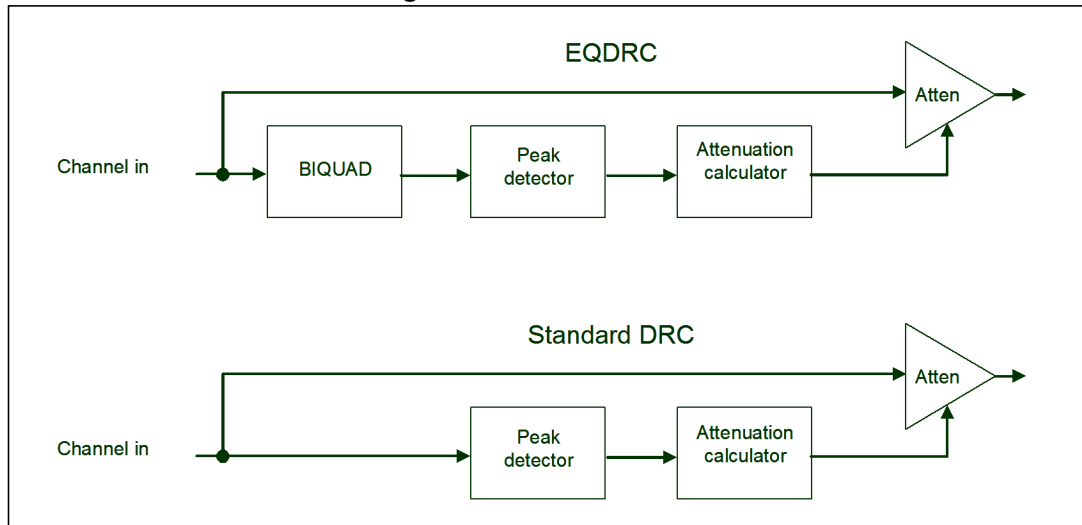

7.18.3 Extended post scale range

Table 78. Post scale setup

| PS48DB | Mode |
|--------|---|
| 0 | Postscale value is applied as defined in coefficient RAM |
| 1 | Postscale value is applied with +48-dB offset with respect to the coefficient RAM value |

Post scale is an attenuation by default. When PS48DB is set to 1, a 48-dB offset is applied to the configured word, so postscale can act as a gain too.

7.18.4 Extended attack rate

The attack rate shown in [Table 67](#) can be extended to provide up to 8 dB/ms attack rate on both limiters.

Table 79. Extended attack rate setup for limiter 1

| XAR1 | Mode |
|------|---|
| 0 | Limiter1 attack rate is configured using Table 67 |
| 1 | Limiter1 attack rate is 8 dB/ms |

Table 80. Extended attack rate setup for limiter 2

| XAR2 | Mode |
|------|---|
| 0 | Limiter2 attack rate is configured using Table 67 |
| 1 | Limiter2 attack rate is 8 dB/ms |

7.18.5 Extended BIQUAD selector

De-emphasis filter as well as bass and treble controls can be configured as user defined filters when equalization coefficients link is activated (BQL = 1) and the corresponding BQx bit is set to 1.

Table 81. De-emphasis filter setup

| BQ5 | Mode |
|-----|---|
| 0 | Preset de-emphasis filter selected |
| 1 | User defined biquad 5 coefficients are selected |

Table 82. Bass filter setup

| BQ6 | Mode |
|-----|---|
| 0 | Preset bass filter selected as per Table 66 |
| 1 | User defined biquad 6 coefficients are selected |

Table 83. Treble filter setup

| BQ7 | Mode |
|-----|---|
| 0 | Preset treble filter selected as per Table 66 |
| 1 | User defined biquad 7 coefficients are selected |

When filters from 5th to 7th are configured as user-programmable, the corresponding coefficients are stored respectively in addresses 0x20-0x24 (BQ5), 0x25-0x29 (BQ6), 0x2A-0x2E (BQ7) as in [Table 73](#).

Note: BQx bits are ignored if BQL = 0 or if DEMP = 1 (relevant for BQ5) or CxTCB = 1 (relevant for BQ6 and BQ7).

7.19 EQ soft volume configuration registers (addr 0x37 - 0x38)

| D7 | D6 | D5 | D4 | D3 | D2 | D1 | D0 |
|----------|----|-------|---------|---------|---------|---------|---------|
| Reserved | | SVUPE | SVUP[4] | SVUP[3] | SVUP[2] | SVUP[1] | SVUP[0] |
| 0 | 0 | 0 | 0 | 0 | 0 | 0 | 0 |

| D7 | D6 | D5 | D4 | D3 | D2 | D1 | D0 |
|----------|----|-------|---------|---------|---------|---------|---------|
| Reserved | | SVDWE | SVDW[4] | SVDW[3] | SVDW[2] | SVDW[1] | SVDW[0] |
| 0 | 0 | 0 | 0 | 0 | 0 | 0 | 0 |

Soft volume update has a fixed rate by default. Using register 0x37 and 0x38 it is possible to override the default behavior allowing different volume change rates.

It is also possible to independently define the fade-in (volume is increased) and fade-out (volume is decreased) rates according to the desired behavior.

Table 84. Soft volume (increasing) setup

| SVUPE | Mode |
|-------|--|
| 0 | When volume is increased, use the default rate |
| 1 | When volume is increased, use the rates defined by SVUP[4:0] . |

When SVUPE = 1 the fade-in rate is defined by the SVUP[4:0] bits according to the formula:

$$\text{Fade-in rate} = 48 / (\text{SVUP}[4:0] + 1) \text{ dB/ms.}$$

Table 85. Soft volume (decreasing) setup

| SVDWE | Mode |
|-------|--|
| 0 | When volume is decreased, use the default rate |
| 1 | When volume is decreased, use the rates defined by SVDW[4:0] . |

When SVDWE = 1 the fade-out rate is defined by the SVDW[4:0] bits according to the formula:

$$\text{Fade-in rate} = 48 / (\text{SVDW}[4:0] + 1) \text{ dB/ms.}$$

7.20 DRC RMS filter coefficients (addr 0x39 - 0x3E)

| D7 | D6 | D5 | D4 | D3 | D2 | D1 | D0 |
|----------|----------|----------|----------|----------|----------|----------|----------|
| R_C0[23] | R_C0[22] | R_C0[21] | R_C0[20] | R_C0[19] | R_C0[18] | R_C0[17] | R_C0[16] |
| 0 | 0 | 0 | 0 | 0 | 0 | 0 | 1 |

| D7 | D6 | D5 | D4 | D3 | D2 | D1 | D0 |
|----------|----------|----------|----------|----------|----------|---------|---------|
| R_C0[15] | R_C0[14] | R_C0[13] | R_C0[12] | R_C0[11] | R_C0[10] | R_C0[9] | R_C0[8] |
| 1 | 1 | 1 | 0 | 1 | 1 | 1 | 0 |

| D7 | D6 | D5 | D4 | D3 | D2 | D1 | D0 |
|---------|---------|---------|---------|---------|---------|---------|---------|
| R_C0[7] | R_C0[6] | R_C0[5] | R_C0[4] | R_C0[3] | R_C0[2] | R_C0[1] | R_C0[0] |
| 1 | 1 | 1 | 1 | 1 | 1 | 1 | 1 |

| D7 | D6 | D5 | D4 | D3 | D2 | D1 | D0 |
|----------|----------|----------|----------|----------|----------|----------|----------|
| R_C1[23] | R_C1[22] | R_C1[21] | R_C1[20] | R_C1[19] | R_C1[18] | R_C1[17] | R_C1[16] |
| 0 | 1 | 1 | 1 | 1 | 1 | 1 | 0 |

| D7 | D6 | D5 | D4 | D3 | D2 | D1 | D0 |
|----------|----------|----------|----------|----------|----------|---------|---------|
| R_C1[15] | R_C1[14] | R_C1[13] | R_C1[12] | R_C1[11] | R_C1[10] | R_C1[9] | R_C1[8] |
| 1 | 1 | 0 | 0 | 0 | 0 | 0 | 0 |

| D7 | D6 | D5 | D4 | D3 | D2 | D1 | D0 |
|---------|---------|---------|---------|---------|---------|---------|---------|
| R_C1[7] | R_C1[6] | R_C1[5] | R_C1[4] | R_C1[3] | R_C1[2] | R_C1[1] | R_C1[0] |
| 0 | 0 | 1 | 0 | 0 | 1 | 1 | 0 |

Signal level detection in DRC algorithm is computed using the following formula:

$$y(t) = c0 * \text{abs}(x(t)) + c1 * y(t-1)$$

where x(t) represents the audio signal applied to the limiter, and y(t) the measured level.

8 Application

8.1 Application scheme for power supplies

Here in *Figure 23* below is the typical application diagram for STA339BW showing the power supply decoupling. Particular care has to be taken with the layout of the PCB. In particular the 3.3 Ω resistors on the digital supplies (VDD_DIG) have to be placed as close as possible to the device. This helps to prevent unwanted oscillation in the digital part of the device due to the inductive tracks of the PCB. The same rule also applies to all the decoupling capacitors in order to limit spikes on all the supplies.

Figure 23. Application diagram

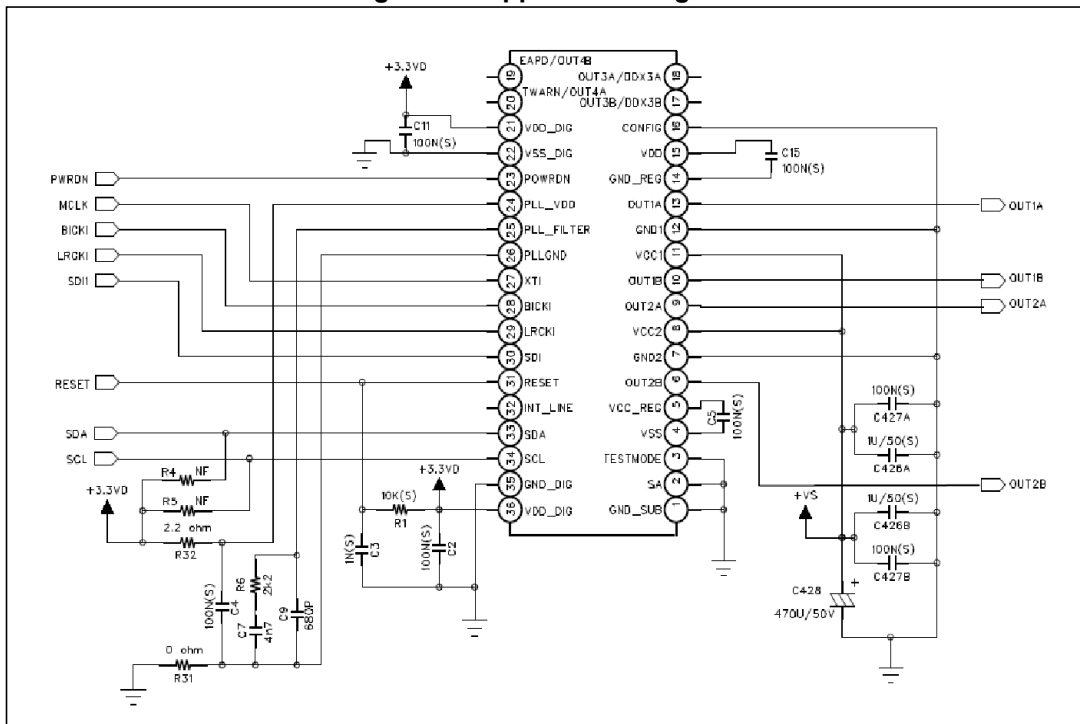

8.2 PLL filter

It is recommended to use the above scheme and values for the PLL filter to achieve the best performance from the device in general applications. Note that the ground of this filter circuit has to be connected to the ground of the PLL without any resistive path.

Concerning the component values, remember that the greater is the filter bandwidth, the less is the lock time but the higher is the PLL output jitter.

8.3 Typical output configuration

Here after the typical output configuration used for BTL stereo mode. Please refer to the application note for all the other possible output configuration recommended schematics.

Figure 24. Output configuration for stereo BTL mode

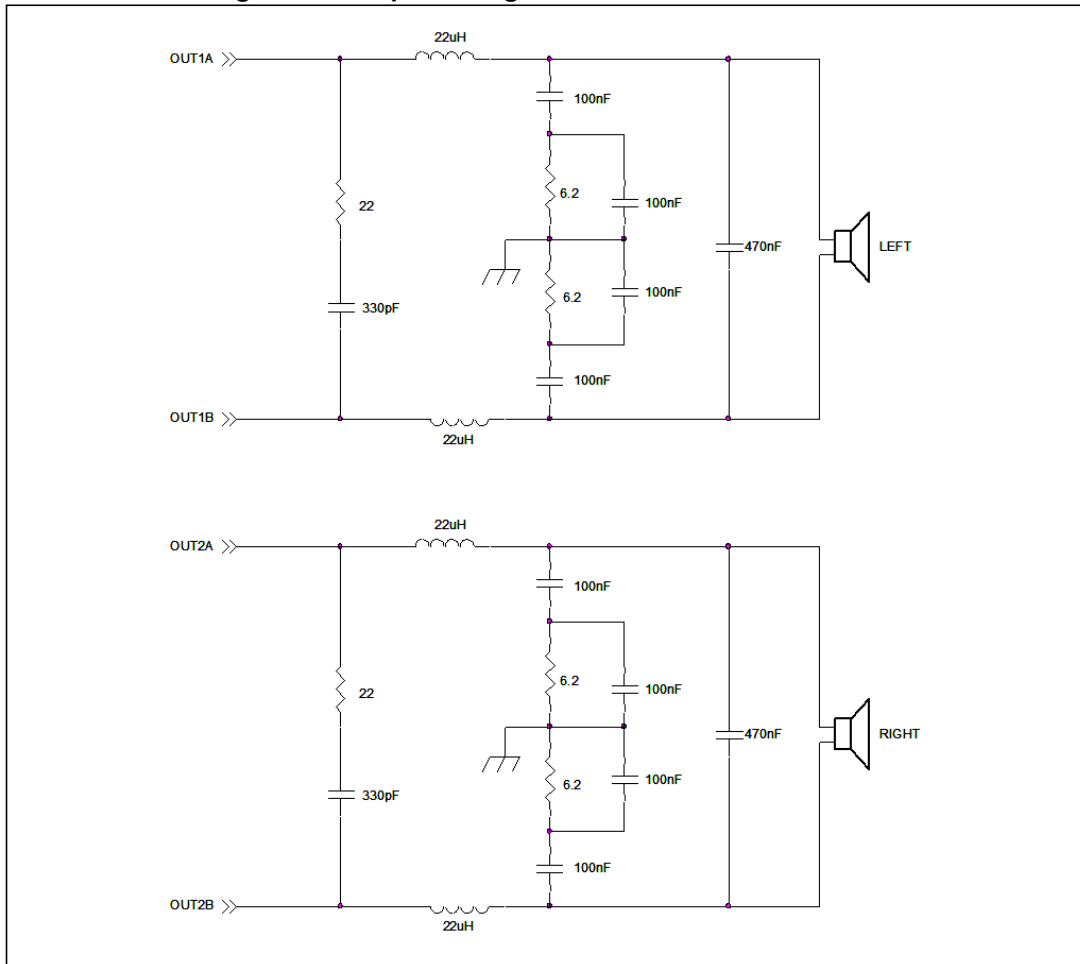

9 Package thermal characteristics

Using a double-layer PCB the thermal resistance junction to ambient with 2 copper ground areas of 3 x 3 cm² and with 16 via holes (see [Figure 25](#)) is 24 °C/W in natural air convection.

The dissipated power within the device depends primarily on the supply voltage, load impedance and output modulation level.

Thus, the maximum estimated dissipated power for the STA339BW is:

$$2 \times 20 \text{ W @ } 8 \Omega, 18 \text{ V} \quad P_{d \text{ max}} \sim 4 \text{ W}$$

$$2 \times 10 \text{ W} + 1 \times 20 \text{ W @ } 4 \Omega, 8 \Omega, 18 \text{ V} \quad P_{d \text{ max}} < 5 \text{ W}$$

Figure 25. Double-layer PCB with 2 copper ground areas and 16 via holes

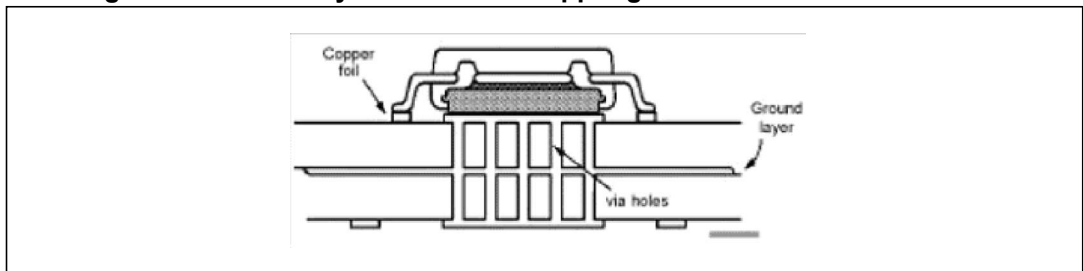

[Figure 26](#) shows the power derating curve for the PowerSSO-36 slug-down package on PCBs with copper areas of 2 x 2 cm² and 3 x 3 cm².

Figure 26. PowerSSO-36 power derating curve

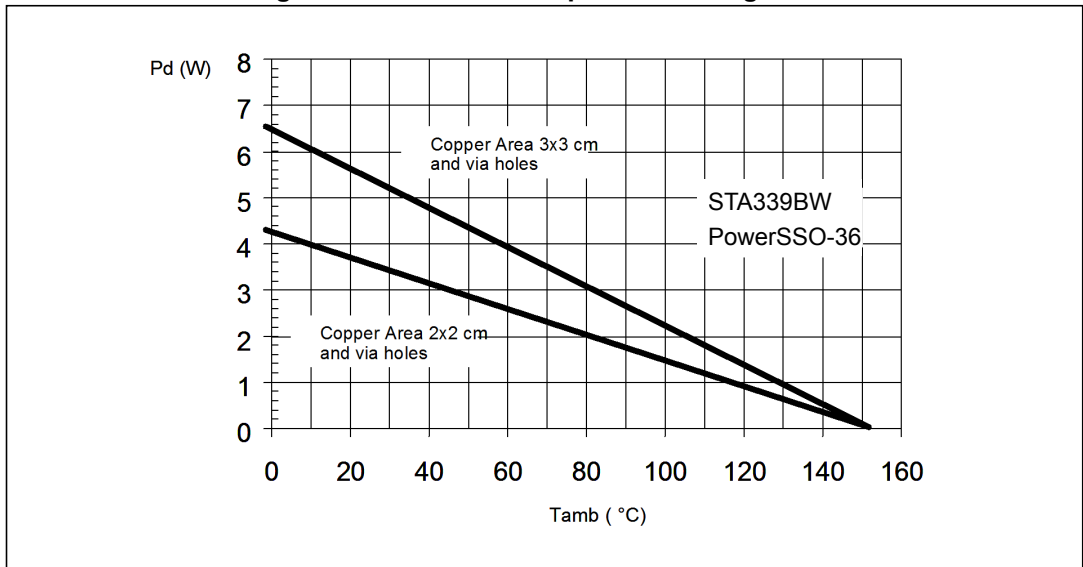

10 Package mechanical data

In order to meet environmental requirements, ST offers these devices in different grades of ECOPACK® packages, depending on their level of environmental compliance. ECOPACK® specifications, grade definitions and product status are available at: www.st.com. ECOPACK® is an ST trademark.

Figure 27 shows the package outline and Table 86 gives the dimensions of the PowerSSO-36 package with exposed pad (slug) down (EPD).

Table 86. PowerSSO-36 EPD dimensions

| Symbol | Dimensions in mm | | | Dimensions in inches | | |
|--------|------------------|------|------------|----------------------|-------|------------|
| | Min | Typ | Max | Min | Typ | Max |
| A | 2.15 | - | 2.47 | 0.085 | - | 0.097 |
| A2 | 2.15 | - | 2.40 | 0.085 | - | 0.094 |
| a1 | 0 | - | 0.10 | 0 | - | 0.004 |
| b | 0.18 | - | 0.36 | 0.007 | - | 0.014 |
| c | 0.23 | - | 0.32 | 0.009 | - | 0.013 |
| D | 10.10 | - | 10.50 | 0.398 | - | 0.413 |
| E | 7.40 | - | 7.60 | 0.291 | - | 0.299 |
| e | - | 0.5 | - | - | 0.020 | - |
| e3 | - | 8.5 | - | - | 0.335 | - |
| F | - | 2.3 | - | - | 0.091 | - |
| G | - | - | 0.10 | - | - | 0.004 |
| H | 10.10 | - | 10.50 | 0.398 | - | 0.413 |
| h | - | - | 0.40 | - | - | 0.016 |
| k | 0 | - | 8 degrees | - | - | 8 degrees |
| L | 0.60 | - | 1.00 | 0.024 | - | 0.039 |
| M | - | 4.30 | - | - | 0.169 | - |
| N | - | - | 10 degrees | - | - | 10 degrees |
| O | - | 1.20 | - | - | 0.047 | - |
| Q | - | 0.80 | - | - | 0.031 | - |
| S | - | 2.90 | - | - | 0.114 | - |
| T | - | 3.65 | - | - | 0.144 | - |
| U | - | 1.00 | - | - | 0.039 | - |
| X | 4.10 | - | 4.70 | 0.161 | - | 0.185 |
| Y | 4.90 | - | 7.10 | 0.193 | - | 0.280 |

Figure 27. PowerSSO-36 EPD outline drawing

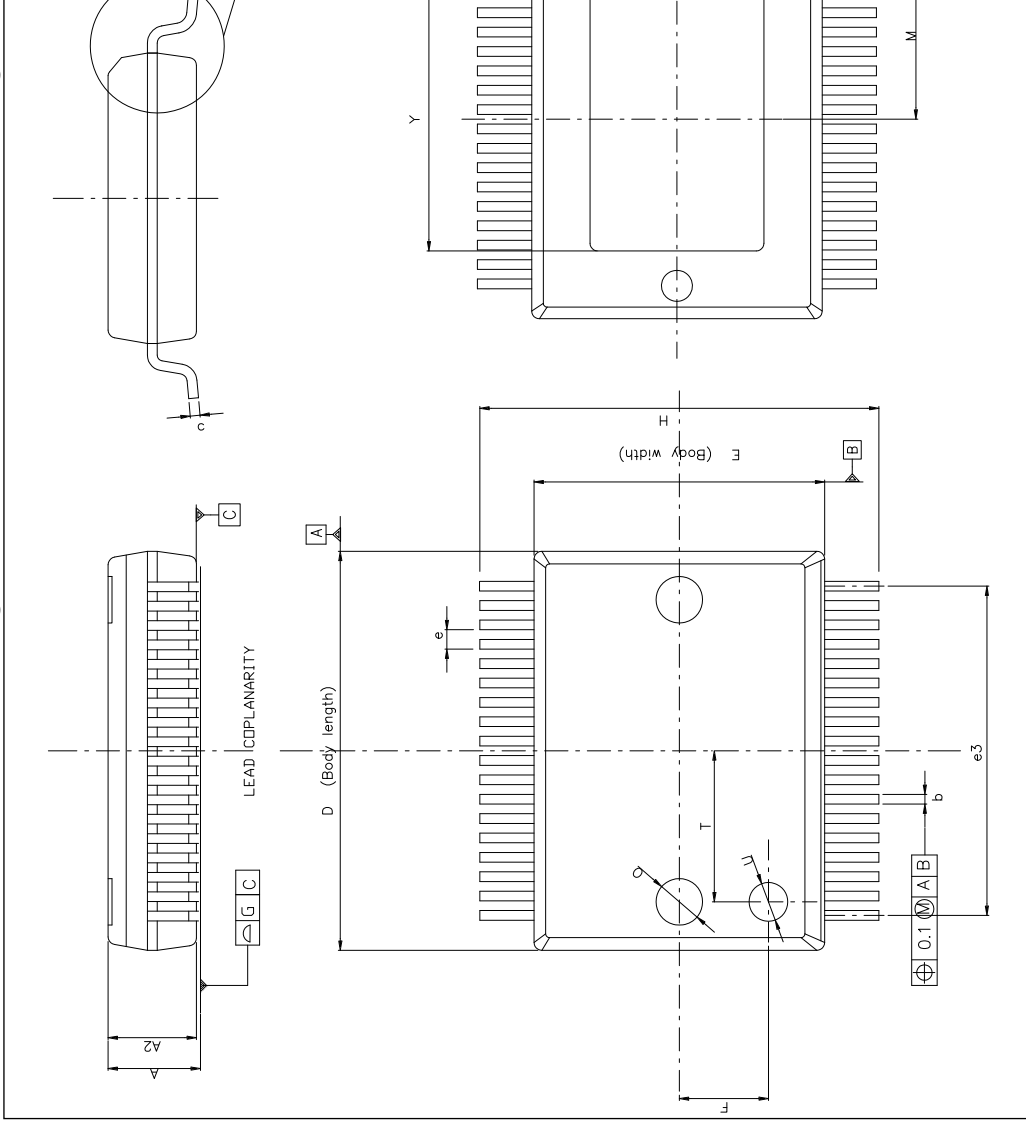

11 Revision history

Table 87. Document revision history

| Date | Revision | Changes |
|-------------|----------|--|
| 09-Dec-2008 | 1 | Initial release |
| 16-Feb-2009 | 2 | Updated names/descriptions for pins 17-20 in Chapter 2 on page 12 Added cross reference to I ² S interface setup in Section 3.6: Power on/off sequence on page 18 Updated text and Figure 23: Application diagram on page 72 Updated Section 8.2: PLL filter on page 72 |
| 01-Apr-2009 | 3 | Updated Y dimension in Table 86: PowerSSO-36 EPD dimensions on page 75 |
| 15-May-2009 | 4 | Updated Chapter 1 on page 10 to "8 programmable 28-bit biquads" Updated I _{ij} and I _{ih} in Table 6: Electrical specifications - digital section on page 15 Updated I _{lim} and I _{sc} in Table 7: Electrical specifications - power section on page 16 Updated register FDRC addresses in Section 7.1.5: Fault detect recovery bypass on page 30 Updated bits 4 and 5 in Table 74: Status register bits on page 65 . |
| 04-Aug-2010 | 5 | Updated order code in Table 1: Device summary on page 1 Updated name of Chapter 10 on page 75 to Package mechanical data |
| 18-Sep-2013 | 6 | Added Section 4 on page 20 Modified Note:: The read write operation on RAM coefficients works only if RLCKI (pin29) is switching and stable (ref. Table 9, tLRJT timing) and PLL must be locked (ref bit D7 reg 0x2D). on page 60 Updated Company information appearing on last page of document |
| 13-Feb-2014 | 7 | Updated order code in Table 1 on page 1 |
| 05-Jan-2015 | 8 | Updated I _{lim} in Table 7: Electrical specifications - power section |

IMPORTANT NOTICE – PLEASE READ CAREFULLY

STMicroelectronics NV and its subsidiaries ("ST") reserve the right to make changes, corrections, enhancements, modifications, and improvements to ST products and/or to this document at any time without notice. Purchasers should obtain the latest relevant information on ST products before placing orders. ST products are sold pursuant to ST's terms and conditions of sale in place at the time of order acknowledgement.

Purchasers are solely responsible for the choice, selection, and use of ST products and ST assumes no liability for application assistance or the design of Purchasers' products.

No license, express or implied, to any intellectual property right is granted by ST herein.

Resale of ST products with provisions different from the information set forth herein shall void any warranty granted by ST for such product.

ST and the ST logo are trademarks of ST. All other product or service names are the property of their respective owners.

Information in this document supersedes and replaces information previously supplied in any prior versions of this document.

© 2015 STMicroelectronics – All rights reserved

Looking for pricing, stock, or lifecycle information?

Click below to explore more details on WIN SOURCE:

- ⊖ [View STA339BWTR on WIN SOURCE](#)
- ⊖ [STMicroelectronics Information](#)

Optimize Your Supply Chain with WIN SOURCE Solutions

- ✓ Global Sourcing Solution
- ✓ Obsolete Management
- ✓ Cost Control Management
- ✓ Shortage Management
- ✓ Alternative Solution
- ✓ Excess Inventory Management