



THE DATASHEET OF STA2500DTR



Bluetooth™ V2.1 + EDR ("Lisbon") for automotive applications

Features

- Based on Ericsson technology licensing baseband core (EBC)
- Bluetooth™ specification compliance: V2.1 + EDR ("Lisbon")
 - Point-to-point, point-to-multipoint (up to 7 slaves) and scatternet capability
 - Support ACL and SCO links
 - Extended SCO (eSCO) links
 - Faster connection
- HW support for packet types
 - ACL: DM1, DM3, DM5, DH1, DH3, DH5, 2-DH1, 2-DH3, 2-DH5, 3-DH1, 3-DH3, 3-DH5
 - SCO: HV1, HV3 and DV
 - eSCO: EV3, EV4, EV5, 2-EV3, 2-EV5, 3-EV3, 3-EV5
- Adaptive frequency hopping (AFH)
- Channel quality driven data rate (CQDDR)
- "Lisbon" features
 - Encryption pause/resume (EPR)
 - Extended inquiry response (EIR)
 - Link supervision time out (LSTO)
 - Secure simple pairing
 - Sniff subrating
 - Quality of service (QoS)
Packet boundary flag
Erroneous data delivery
- Transmit power
 - Power class 2 and power class 1.5 (above 4 dBm)
 - Programmable output power
 - Power class 1 compatible
- HCI
 - HCI H4 and enhanced H4 transport layer
 - HCI proprietary commands (e.g. peripherals control)
 - Single HCI command for patch/upgrade download
 - eSCO over HCI supported
- Supports pitch-period error concealment (PPEC)
- Efficient and flexible support for WLAN coexistence scenarios



LFBGA48 (6x6x1.4mm; 0.8mm Pitch)

- Low power consumption
 - Ultra low power architecture with 3 different low-power levels
 - Deep sleep modes, including host-power saving feature
 - Dual wake-up mechanism: initiated by the host or by the Bluetooth device
- Communication interfaces
 - Fast UART up to 4 MHz
 - Flexible SPI interface up to 13 MHz
 - PCM interface
 - Up to 10 additional flexibly programmable GPIOs
 - External interrupts possible through the GPIOs
 - Fast I²C interface as master
- Clock support
 - System clock input (digital or sine wave) at 9.6, 10, 13, 16, 16.8, 19.2, 26, 33.6 or 38.4 MHz
 - Low power clock input at 3.2 kHz, 32 kHz and 32.768 kHz
- ARM7TDMI CPU
- Memory organization
 - On chip RAM, including provision for patches
 - On chip ROM, preloaded with SW up to HCI
- Ciphering support up to 128-bit key
- Single power supply with internal regulators for core voltage generation
- Supports 1.65 V to 2.85 V I/O systems
- Auto calibration (VCO, filters)

Contents

1	Description	6
2	Quick reference data	7
	2.1 Absolute maximum ratings	7
	2.2 Operating ranges	7
	2.3 I/O specifications	8
	2.4 Clock specifications	8
	2.5 Current consumption	10
3	Block diagram and electrical schematic	12
4	Pinout	13
	4.1 Pin description and assignment	13
	4.2 HW configuration of the STA2500D	16
	4.3 I/O Supply	17
5	Functional description	18
	5.1 Transmitter	18
	5.2 Receiver	18
	5.3 PLL	18
	5.4 Bluetooth controller V1.2 and V2.0 + EDR features	19
	5.5 Bluetooth controller V2.1 + EDR (“Lisbon”)	19
	5.6 Processor and memory	19
	5.7 TX output power control	20
6	General specification	21
	6.1 Receiver	21
	6.2 Transmitter	24
	6.3 Class 1 operation	26
	6.4 Power-up	26
	6.5 System clock	27
	6.6 Low power clock	27
	6.7 Clock detection	27

6.8	Clock request signals	27
6.9	Interrupts	29
6.10	Low power modes	29
6.10.1	Overview	29
6.10.2	Some examples for the usage of the low power modes	30
6.10.3	Deep sleep mode entry and wake-up	30
6.11	Patch RAM	37
6.12	Download of SW parameter file	37
6.13	Bluetooth - WLAN coexistence in collocated scenario	38
6.13.1	Algorithm 1: PTA (packet traffic arbitration)	38
6.13.2	Algorithm 2: WLAN master	39
6.13.3	Algorithm 3: Bluetooth master	39
6.13.4	Algorithm 4: two-wire mechanism	39
6.13.5	Algorithm 5: Alternating wireless medium access (AWMA)	40
7	Digital interfaces	41
7.1	The UART interface	41
7.2	The SPI interface	41
7.3	The PCM interface	43
7.4	The JTAG interface	46
7.5	Alternate I/O functions	46
7.6	The I ² C interface	47
8	HCI transport layer	48
8.1	H4 UART transport layer	48
8.2	Enhanced H4 SPI transport layer	49
8.3	H4 SPI transport layer	49
8.4	eSCO over HCI	49
9	Package information	50
10	References	52
11	Acronyms and abbreviations	53
12	Order codes	56
13	Revision history	57

List of tables

Table 1.	Absolute maximum ratings	7
Table 2.	Operating ranges	7
Table 3.	DC input specification	8
Table 4.	DC output specification	8
Table 5.	System clock supported frequencies	8
Table 6.	System clock overall specifications	8
Table 7.	System clock, sine wave specifications	9
Table 8.	System clock, digital clock DC specifications	9
Table 9.	System clock, digital clock AC specifications	9
Table 10.	Low power clock specifications.	9
Table 11.	Current consumption	10
Table 12.	The STA2500D pin list (functional and supply).	14
Table 13.	Configuration programming	17
Table 14.	I/O supply split diagram	17
Table 15.	Mbps receiver parameters - GFSK	21
Table 16.	Mbps receiver parameters - $\pi/4$ -DQPSK	22
Table 17.	Mbps receiver parameters - 8-DPSK	23
Table 18.	Transmitter parameters	24
Table 19.	Output power: class 1 control signals	26
Table 20.	Output power: class 1 device pin configuration (depending on SW parameter download).	26
Table 21.	Output power: class 1 device pin configuration (depending on SW parameter download).	26
Table 22.	Use of the BT_CLK_REQ_IN and BT_CLK_REQ_OUT signals in different modes.	28
Table 23.	Low power modes.	29
Table 24.	WLAN HW signal assignment.	40
Table 25.	SPI timing parameters	43
Table 26.	PCM interface parameters	45
Table 27.	PCM interface timing (at PCM_CLK = 2048 kHz).	45
Table 28.	Examples of BT_GPIO pin programming	46
Table 29.	Package markings legend	51
Table 30.	References	52
Table 31.	Acronyms and abbreviations	53
Table 32.	Ordering information	56
Table 33.	Document revision history	57

List of figures

Figure 1. Block diagram and electrical schematic 12

Figure 2. Pinout (bottom view) 13

Figure 3. Active high clock request input and output combined with UART or SPI 28

Figure 4. Active low clock request input and output combined with UART 28

Figure 5. Active low clock request input and output combined with SPI 28

Figure 6. Deep sleep mode entry and wake-up through H4 UART 32

Figure 7. Entering deep sleep mode through enhanced H4 SPI 33

Figure 8. Wake-up by the host through enhanced H4 SPI 33

Figure 9. Wake-up by the Bluetooth controller with data transmission to the host, through enhanced H4 SPI 34

Figure 10. Deep sleep mode entry and wake-up through H4 SPI 35

Figure 11. Entering deep sleep mode, pending data on UART interface, through UART with handshake 36

Figure 12. Wakeup by host through UART with handshake 37

Figure 13. PTA diagram 38

Figure 14. WLAN master 39

Figure 15. Bluetooth master 39

Figure 16. SPI interface 41

Figure 17. SPI data transfer timing for data length of 8 bits and lsb first, full duplex 42

Figure 18. SPI setup and hold timing 43

Figure 19. PCM (A-law, μ -law) standard mode 44

Figure 20. Linear mode 44

Figure 21. Multislot operation 44

Figure 22. PCM interface timing 45

Figure 23. UART transport layer 48

Figure 24. LFBGA48 (6x6x1.4mm) mechanical data and package dimensions 50

Figure 25. Package markings 51

1 Description

The STA2500D is a single chip Bluetooth solution that is fully optimized for automotive applications such as telematics, navigation and portable navigation. Power consumption levels are targeted at battery powered devices and single chip solution brings cost advantages. Manufacturers can easily and quickly integrate the STA2500D on their product to enable a rapid time to market.

STA2500D supports the Bluetooth specification V2.1 + EDR (“Lisbon”) and is optimized in terms of RF performance and cost.

The STA2500D is a ROM-based solution targeted at applications requiring integration up to HCI level. Patch RAM is available, enabling multiple patches/upgrades and fast time to volume. The STA2500D’s main interfaces are UART or SPI for HCI transport, PCM for voice and GPIOs for control purposes.

The radio has been designed specifically for single chip requirements, for low power consumption and minimum BOM count.

2 Quick reference data

BT_VIO_x means BT_VIO_A, BT_VIO_B.

BT_HVx means BT_HVA, BT_HVD.

(See also [Table 12](#).)

2.1 Absolute maximum ratings

The absolute maximum rating (AMR) corresponds to the maximum value that can be applied without leading to instantaneous or very short-term unrecoverable hard failure (destructive breakdown).

Table 1. Absolute maximum ratings

Symbol	Parameter	Min.	Max.	Unit
BT_HVx	Core supply voltages	-0.3	4.0	V
BT_VIO_A	Supply voltage I/O	-0.3	4.0	V
BT_VIO_B	Supply voltage I/O (for the low power clock)	-0.3	4.0	V
BT_V _{in}	Input voltage of any digital pin	-0.3	4.0	V
V _{ssdiff}	Maximum voltage difference between different types of V _{SS} pins.	-0.3	0.3	V
T _{stg}	Storage temperature	- 65	+ 150	°C

2.2 Operating ranges

Operating ranges define the limits for functional operation and parametric characteristics of the device. Functionality outside these limits is not implied.

Table 2. Operating ranges

Symbol	Parameter	Min.	Typ.	Max.	Unit
BT_T _{amb}	Operating ambient temperature	-40	25	+85	°C
BT_HVx	Core supply voltages	2.65	2.75	2.85	V
BT_VIO_A	I/O supply voltage	1.65	-	2.85	V
BT_VIO_B	I/O supply voltage (for the low power clock)	1.17	-	2.85	V

2.3 I/O specifications

The I/Os comply with the EIA/JEDEC standard JESD8-B.

Table 3. DC input specification

Symbol	Parameter	Min.	Typ.	Max.	Unit
V_{IL_BT}	Low level input voltage	-0.2	-	0.35 * BT_VIO_x	V
V_{IH_BT}	High level input voltage	0.65 * BT_VIO_x	-	(BT_VIO_x + 0.2) and (≤ 2.85)	V
C_{in_BT}	Input capacitance ⁽¹⁾	1	-	2.5	pF
R_{pu}	Pull-up equivalent resistance (with $V_{in} = 0$ V)	31	47	73	k Ω
R_{pd}	Pull-down equiv. resistance (with $V_{in} = BT_VIO_x$)	29	50	100	k Ω
V_{hyst}	Schmitt trigger hysteresis (at BT_VIO_A = 1.8 V) except for BT_CONFIG1-3, BT_RESETN, BT_WAKEUP	0.4	0.5	0.6	V
V_{hyst}	Schmitt trigger hysteresis (at BT_VIO_x = 1.8 V) for BT_CONFIG1-3, BT_RESETN, BT_WAKEUP, BT_LP_CLK	0.223	-	0.314	V
V_{hyst}	Schmitt trigger hysteresis (at BT_VIO_B = 1.3 V)	0.2	-	0.3	V

1. Except for the system clock.

Table 4. DC output specification

Symbol	Parameter	Condition	Min.	Typ.	Max.	Unit
V_{OL_BT}	Low level output voltage	$I_d = X^{(1)}$ mA	-	-	0.15	V
V_{OH_BT}	High level output voltage	$I_d = X^{(1)}$ mA	BT_VIO_x - 0.25	-	-	V

1. X is the source/sink current under worst-case conditions according to the drive capabilities (see [Section 3](#))

2.4 Clock specifications

The STA2500D supports, on the BT_REF_CLK_IN pin, the system clock both as a sine wave clock and as a digital clock. For configuration, see [Table 12](#): pin BT_VDD_CLD (E6).

Table 5. System clock supported frequencies

Symbol	Parameter	Values	Unit
F_{IN}	Clock input frequency list	9.6, 10, 13, 16, 16.8, 19.2, 26, 33.6, 38.4	MHz

Table 6. System clock overall specifications

Symbol	Parameter	Min.	Typ.	Max.	Unit
F_{INTOL}	Tolerance on input frequency	-20	-	20	ppm

Table 7. System clock, sine wave specifications

Symbol	Parameter	Min.	Typ.	Max.	Unit
V _{PP}	Peak to peak voltage range	0.27	0.5	1.8	V
N _H	Total harmonic content of input signal	-	-	-25	dBc
Z _{INRe}	Real part of parallel input impedance at pin	30	60	90	kΩ
Z _{INIm}	Imaginary part of parallel input impedance at pin	-	5	8	pF
Z _{IDRe}	Real impedance discrepancy between active and non-active mode of clock input	-	-	7	kΩ
Z _{IDIm}	Imaginary impedance discrepancy between active and non-active mode of clock input	-	-	500	fF
	Phase noise @ 10 kHz ⁽¹⁾	-	-	-126	dBc/Hz

1. Equivalent to max 10 ps time jitter (rms).

Table 8. System clock, digital clock DC specifications

Symbol	Parameter	Min.	Typ.	Max.	Unit
V _{IL}	Low level input voltage	-0.2	-	0.35 * BT_VDD_CLD	V
V _{IH}	High level input voltage	0.65 * BT_VDD_CLD	-	(BT_VDD_CLD + 0.2) and (≤ 2.85)	V
C _{IN}	Input capacitance	-	5	8	pF

Table 9. System clock, digital clock AC specifications

Symbol	Parameter	Min.	Typ.	Max.	Unit
T _{RISE}	10% - 90% rise time	-	1.5	6	ns
T _{FALL}	90% - 10% fall time	-	1.5	6	ns
D _{CYCLE}	Duty cycle	45	50	55	%
-	Phase noise @ 10 kHz ⁽¹⁾	-	-	-121	dBc/Hz

1. Equivalent to max 15 ps time jitter (rms).

Table 10. Low power clock specifications

The low power clock pin is powered by connecting BT_VIO_B to the wanted supply.

Symbol	Parameter	Min.	Typ.	Max.	Unit
F _{IN}	Clock input frequencies	3.2, 32, 32.768			kHz
-	Duty cycle	30	-	70	%
-	Tolerance on input frequency	-250	-	250	ppm
V _{IL}	Low level input voltage	-	-	0.35 * BT_VIO_B	V
V _{IH}	High level input voltage	0.65 * BT_VIO_B	-	-	V
V _{hyst}	Schmitt trigger hysteresis (BT_VIO_B = 1.8 V)	0.4	0.5	0.6	V

Table 10. Low power clock specifications (continued)

The low power clock pin is powered by connecting BT_VIO_B to the wanted supply.

Symbol	Parameter	Min.	Typ.	Max.	Unit
V_{hyst}	Schmitt trigger hysteresis (BT_VIO_B = 1.3 V)	0.2	0.3	0.4	V
C_{IN}	Input capacitance	1	-	2.5	pF
T_{RISE}	10% - 90% rise time ⁽¹⁾	-	-	1	μs
T_{FALL}	90% - 10% fall time ⁽¹⁾	-	-	1	μs
-	Total jitter ⁽²⁾	-	-	250	ppm

1. The rise and fall time are not the most important parameters for the low power clock input due to the Schmitt trigger logic. It is more important that the noise on the Low power clock line remains substantially below the hysteresis in amplitude.
2. The total jitter is defined as the error that can appear on the actual frequency between two clock edges compared to the perfect frequency. Due to this, the total jitter value must contain the jitter itself and the error due to the accuracy on the clock frequency. The lower the accuracy, the smaller the jitter is allowed to be.

2.5 Current consumption

$T_{\text{amb}} = 25^{\circ}\text{C}$, 13 MHz digital clock, 7 dBm output power for BR packets, 3 dBm output power for EDR packets.

Table 11. Current consumption⁽¹⁾

State	Typ.	Unit
Complete Power Down	1	μA
Deep Sleep mode	20	μA
Functional Sleep mode ⁽²⁾	1.2	mA
Sniff mode (1.28 s, 2 attempts, 0 timeouts), combined with H4 UART Deep Sleep mode (see section 6.10.3)	55	μA
Master mode	83	μA
Slave mode		
Inquiry scan (1.28 seconds period), combined with H4 UART Deep Sleep mode (see section 6.10.3)	318	μA
HW Page scan (1.28 seconds period), combined with H4 UART Deep Sleep mode (see section 6.10.3)	312	μA
HW Inquiry and Page scan (1.28 seconds period), combined with H4 UART Deep Sleep mode (see section 6.10.3)	591	μA
Idle ACL connection (Master)	3.6	mA
Idle ACL connection (Slave)	8.2	mA
Active: audio (HV3) Master (not sniffed)	11.7	mA
Active: audio (HV3) Slave (Sniff 1.28 s, 2 attempts, 0 timeouts)	10.6	mA
Active: data (DH1) Master or Slave (172.8 kbps asymmetrical in TX mode) (172.8 kbps symmetrical)	23 28.5	mA

Table 11. Current consumption⁽¹⁾ (continued)

State	Typ.	Unit
Active: data (DH5) Master or Slave (723.2 kbps asymmetrical in TX mode) (433.9 kbps symmetrical)	35.4	mA
	35.4	mA
Active: data (2-DH5) Master or Slave (869.7 kbps symmetrical)	35.4	mA
Active: data (3-DH5) Master or Slave (1306.9 kbps symmetrical)	35.4	mA
Active: audio eSCO (EV3), (64 kbps symmetrical $T_{eSCO} = 6$) Master mode Slave mode	12	mA
	15	mA
Active: audio eSCO (2-EV3), (64 kbps symmetrical $T_{eSCO} = 12$) Master mode Slave mode	7.8	mA
	11.7	mA
Active: audio eSCO (3-EV3), (64 kbps symmetrical $T_{eSCO} = 18$) Master mode Slave mode	6.5	mA
	10.5	mA
Active: audio eSCO (EV5), (64 kbps symmetrical $T_{eSCO} = 36$), Master mode	8	mA
Active: audio eSCO (EV5), (64 kbps symmetrical $T_{eSCO} = 36$), Slave mode	11.9	mA
Active: audio eSCO (2-EV5), (64 kbps symmetrical $T_{eSCO} = 36$), Master mode	6.3	mA
Active: audio eSCO (3-EV5), (64 kbps symmetrical $T_{eSCO} = 36$), Master mode	5.75	mA

1. The power consumption (except for power safe modes i.e. complete power down and deep sleep mode) will rise (with approx. 200 μ A) if an analog system clock is used instead of a digital clock.
2. In functional sleep mode, the baseband clock is still running.

3 Block diagram and electrical schematic

Figure 1. Block diagram and electrical schematic

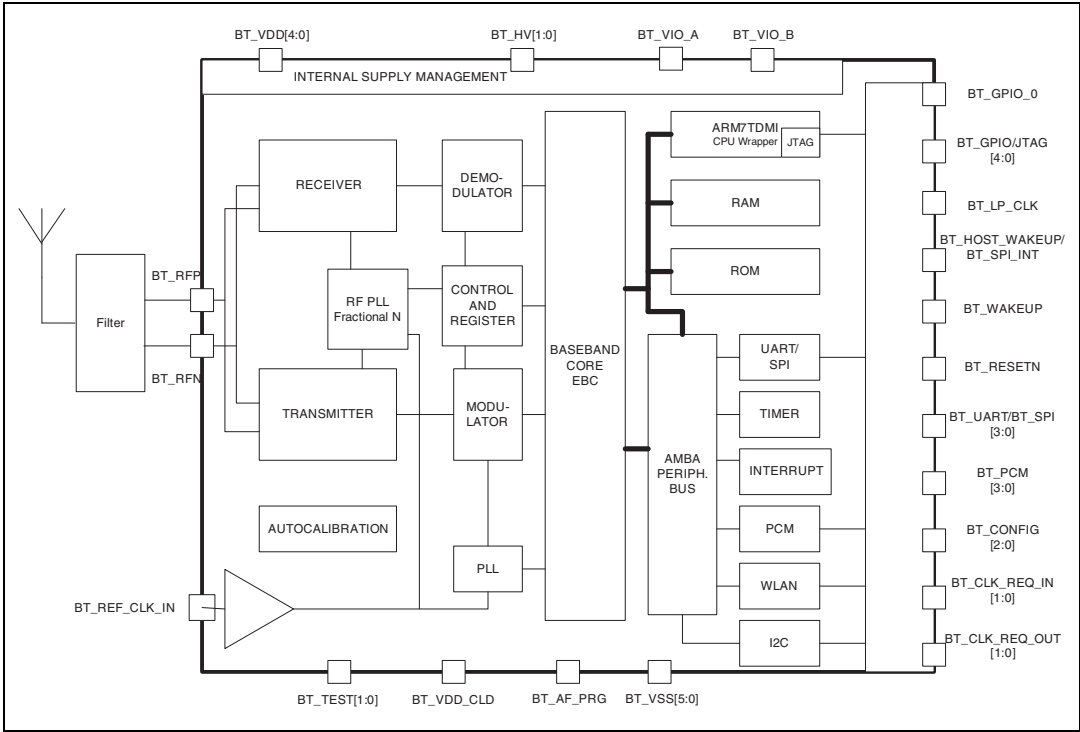

4 Pinout

Figure 2. Pinout (bottom view)

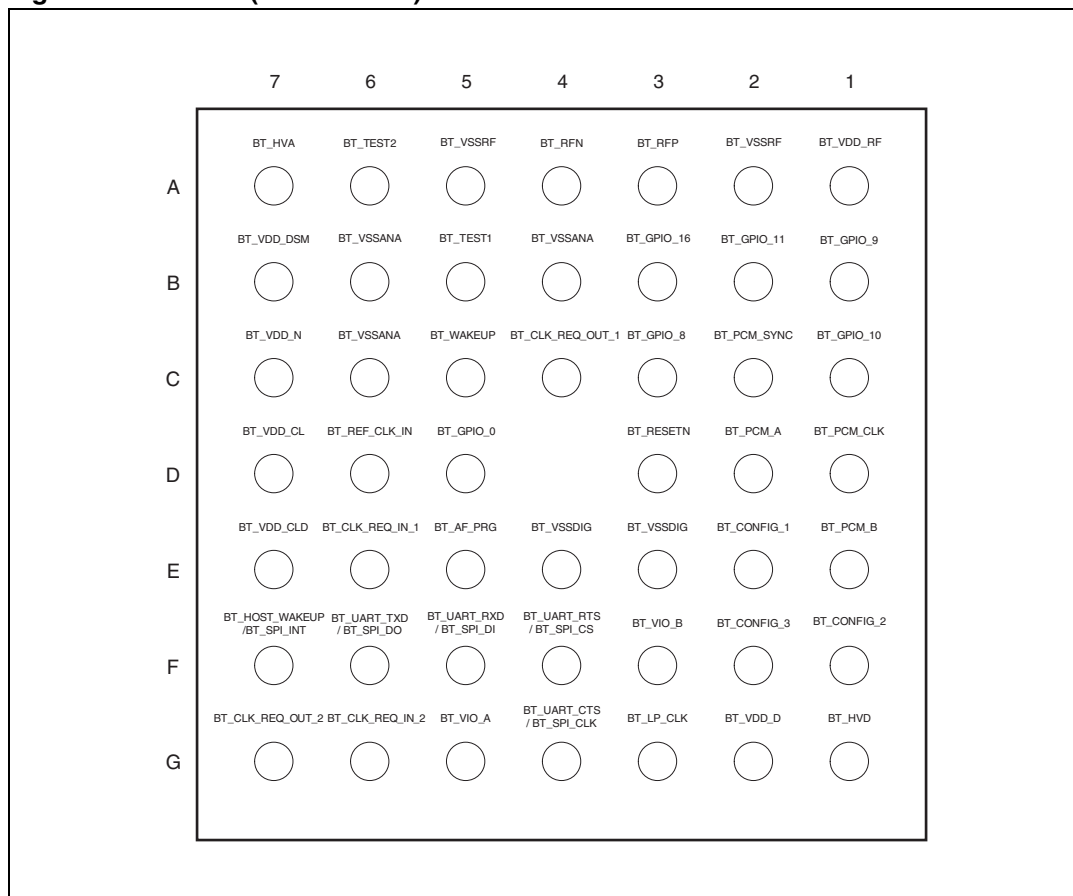

4.1 Pin description and assignment

Table 12 shows the pin list of the STA2500D.

In columns “Reset” and “Default after reset”, the “PD/PU” shows the pads implementing an internal pull-down/up.

The column “Reset” shows the state of the pins during hardware reset; the column “Default after reset” shows the state of the pins after the hardware reset state is left, but before any software parameter download.

The column “Type” describes the pin directions:

- I for Input (All inputs have a Schmitt trigger function.)
- O for Output
- I/O for Input/Output
- O/t for tri-state output

For the output pin the default drive capability is 2 mA, except for pin K3 (BT_GPIO_11) and pin L3 (BT_GPIO_8) where it is 8 mA such that when used for Class 1, these 2 pins can be used for a switch control in a cheaper way.

Table 12. The STA2500D pin list (functional and supply)

Name	Pin #	Description	Type	Reset ⁽¹⁾	Default ⁽²⁾ after reset
Clock and reset pins					
BT_RESETN	D3	Global reset - active low	-	-	
BT_REF_CLK_IN	D6	Reference clock input ⁽³⁾	I	Input	Input
BT_LP_CLK	G3	Low power clock input	-	-	
SW initiated low power mode					
BT_CLK_REQ_OUT_1	C4	Wake-up signal to Host (Active high or Active low, depending on configuration pins)	I/O ⁽⁴⁾	Input PD/PU, depends on config	Output depends on config
BT_CLK_REQ_OUT_2	G7	Wake-up signal to Host. Active low (SPI mode only)		Input PU	I/O depends on config
BT_CLK_REQ_IN_1	E6	Clock request input (Active high)		Input PD	Input PD
BT_CLK_REQ_IN_2	G6	Clock request input (Active low)		Input PU	Input PU
BT_HOST_WAKEUP/ BT_SPI_INT	F7	Wake-up signal to Host or SPI interrupt		Input PD	Output
BT_WAKEUP	C5	Wake-up signal to Bluetooth (Active high)	I/O	Input ⁽⁵⁾	Input
UART interface					
BT_UART_RXD/ BT_SPI_DI	F5	UART receive data	I/O ⁽⁴⁾	Input PD	Input PD
		SPI data in			Input PD
BT_UART_TXD/ BT_SPI_DO	F6	UART transmit data			Output high
		SPI data out			Input PD
BT_UART_CTS/ BT_SPI_CLK	G4	UART clear to send		Input PU	Input PU
		SPI clock			Input PD
BT_UART_RTS/ BT_SPI_CSN	F4	UART request to send	Output low		
		SPI chip select	Input PU		
PCM interface					
BT_PCM_SYNC	C2	PCM frame signal	I/O ⁽⁴⁾	Input PD	Input PD
BT_PCM_CLK	D1	PCM clock signal			
BT_PCM_A	D2	PCM data			
BT_PCM_B	E1	PCM data			
JTAG interface					
BT_GPIO_9	B1	JTAG_TDI or GPIO	-	Input PU ⁽⁶⁾	Input PU ⁽⁶⁾

Table 12. The STA2500D pin list (functional and supply) (continued)

Name	Pin #	Description	Type	Reset ⁽¹⁾	Default ⁽²⁾ after reset
BT_GPIO_11	B2	JTAG_TDO or GPIO	-	Input PD ⁽⁶⁾	Input PD ⁽⁶⁾
BT_GPIO_10	C1	JTAG_TMS or GPIO	I/O ⁽⁴⁾	Input PD ⁽⁶⁾	Input PD ⁽⁶⁾
BT_GPIO_16	B3	JTAG_NTRST (Active low) or Alternate function.	-	Input PD ⁽⁶⁾	Input PD ⁽⁶⁾
BT_GPIO_8	C3	JTAG_TCK or GPIO	-	Input PD ⁽⁶⁾	Input PD ⁽⁶⁾
General purpose input/output pins					
BT_GPIO_0	D5	General purpose I/O	I/O ⁽⁴⁾	Input PD	Input PD
Configuration pins					
BT_CONFIG_1	E2		-	-	-
BT_CONFIG_2	F1	Configuration signal	I	Input	Input
BT_CONFIG_3	F2		-	-	-
RF signals					
BT_RFP	A3	Differential RF port	I/O	-	-
BT_RFN	A4			-	-
Power supply					
BT_HVA	A7	Power supply (Connect to 2.75 V)	-	-	-
BT_HVD	G1				
BT_VIO_A	G5	1.65 V to 2.85 V I/Os supply ⁽⁷⁾	-	-	-
BT_VIO_B	F3	1.17 V to 2.85 V I/Os supply ⁽⁷⁾	-	-	-
BT_VDD_CLD	E7	System clock supply 1.65 V to 2.85 V (Connect to BT_VIO_A in case of a digital reference clock input, to BT_VSSANA in case of an analog reference clock input.)	-	-	-
BT_VSSDIG	E3	Digital ground	-	-	-
	E4				
BT_VSSANA	B4	Analog ground	-	-	-
	B6				
	C6				
BT_VSSRF	A2	RF ground	-	-	-
	A5				
BT_VDD_CL	D7	Internal supply decoupling/Regulator output. Need 220nF decoupling capacitor to BT_VSSANA.	-	-	-

Table 12. The STA2500D pin list (functional and supply) (continued)

Name	Pin #	Description	Type	Reset ⁽¹⁾	Default ⁽²⁾ after reset
BT_VDD_D	G2	Internal supply decoupling/Regulator output. Need 220nF decoupling capacitor to BT_VSSDIG.	-	-	-
BT_VDD_DSM	B7	Internal supply decoupling/Regulator output. Need 220nF decoupling capacitor to BT_VSSANA.	-	-	-
BT_VDD_N	C7	Internal supply decoupling/Regulator output. Need 220nF decoupling capacitor to BT_VSSANA.	-	-	-
BT_VDD_RF	A1	Internal supply decoupling/Regulator output. Need 220nF decoupling capacitor to BT_VSSRF.	-	-	-
Other pins					
BT_TEST1	B5	Test pin	I/O	Input ⁽⁸⁾	Input ⁽⁸⁾
BT_TEST2	A6				
BT_AF_PRG	E5	Test pin (Leave unconnected) ⁽⁹⁾	I/O	Open	Open

1. Pin behaviour during HW reset (BT_RESETN low).
2. Pin behaviour immediately after HW reset and internal chip initialization, but before SW parameter download.
3. See also pin BT_VDD_CLD in [Table 12](#).
4. Reconfigurable I/O pin. The functionality of these I/Os can be configured through software parameter download (see [Section 7.5](#)).
5. Should be strapped to BT_VSSDIG if not used.
6. JTAG mode.
7. Described in [Section 4.3](#).
8. To be strapped to BT_VSSANA.
9. Pin is ST - reserved for test function and it must be soldered to an isolated pad (not connected to anything, just floating).

4.2 HW configuration of the STA2500D

By means of the three configuration pins, one can select the Host interface (UART or SPI) and clock request signal polarity to be used at startup.

The available combinations of Host interface and protocol are illustrated in [Table 13](#) (where '1' = BT_VIO_A and '0' = BT_VSSDIG). Additionally, the polarity of the BT_CLK_REQ signals can be programmed through the same pins. The polarity of the BT_CLK_REQ_IN and BT_CLK_REQ_OUT signals is further described in [Section 6.8](#).

Table 13. Configuration programming

BT_CONFIG_1	BT_CONFIG_2	BT_CONFIG_3	Communication Protocol	BT_CLK_REQ_OUT_1	BT_CLK_REQ_OUT_2
0	1	0	H4 UART	Active high	Depending on SW config
0	1	1	H4 UART	Active low	Depending on SW config
1	1	0	Reserved	Reserved	Reserved
1	1	1	Reserved	Reserved	Reserved
1	0	0	Reserved	Reserved	Reserved
1	0	1	Enhanced H4 SPI ⁽¹⁾	Active high	Active low
0	0	1	Reserved	Reserved	Reserved
0	0	0	Reserved	Reserved	Reserved

1. In order to get other SPI modes, the Host must send a specific configuration at start-up in addition of these configuration pins.

4.3 I/O Supply

The device STA2500D has two different I/O supplies: BT_VIO_A and BT_VIO_B.

The two different pins may be potentially connected to separate dedicated voltage supplies in order to harmonize the digital levels to the platform.

They are linked to different interfaces as described in [Table 14](#).

Table 14. I/O supply split diagram

I/O supply name	Voltage range [V]	Function	Associated pins
BT_VIO_A	1.65 - 2.85	Configuration	BT_CONFIG_1, BT_CONFIG_2, BT_CONFIG_3
		Control	BT_WAKEUP
			BT_RESETN
			BT_CLK_REQ_OUT_1, BT_CLK_REQ_OUT_2
		GPIO (JTAG)	BT_GPIO_8 (JTAG_TCK), BT_GPIO_9 (JTAG_TDI), BT_GPIO_10 (JTAG_TMS), BT_GPIO_11 (JTAG_TDO), BT_GPIO_16 (JTAG_NTRST)
		PCM	BT_PCM_A, BT_PCM_B, BT_PCM_SYNC, BT_PCM_CLK
		Control	BT_REG_CTRL
		UART (SPI)	BT_UART_RXD (SPI_DI), BT_UART_TXD (SPI_DO), BT_UART_RTS (SPI_CSN), BT_UART_CTS (SPI_CLK), BT_HOST_WAKEUP (SPI_INT)
		Control (GPIO)	BT_CLK_REQ_IN_1 (GPIO_1), BT_CLK_REQ_IN_2 (GPIO_2)
GPIO	BT_GPIO_0		
BT_VIO_B	1.17 - 2.85	Low - power clock	BT_LP_CLK

5 Functional description

5.1 Transmitter

The transmitter uses the serial transmit data from the Bluetooth Controller. The transmitter modulator converts this data into GFSK, $\pi/4$ -DQPSK or 8-DPSK modulated I and Q digital signals for respectively 1, 2 and 3 Mbps transmission speed. These signals are then converted to analog signals that are low pass filtered before up-conversion. The carrier frequency drift is limited by a closed loop PLL.

5.2 Receiver

The STA2500D implements a low-IF receiver for Bluetooth modulated input signals. The radio signal is taken from a balanced RF input and amplified by an LNA. The mixers are driven by two quadrature LO signals, which are locally generated from a VCO signal running at twice the frequency. The I and Q mixer output signals are band pass filtered by a poly-phase filter for channel filtering and image rejection. The output of the band pass filter is amplified by a VGA to the optimal input range for the A/D converter. Further channel filtering is done in the digital part. The digital part demodulates the GFSK, $\pi/4$ -DQPSK or 8-DPSK coded bit stream by evaluating the phase information. RSSI data is extracted. Overall automatic gain amplification in the receive path is controlled digitally. The RC time constants for the analog filters are automatically calibrated on chip.

5.3 PLL

The on chip VCO is part of a PLL. The tank resonator circuitry for the VCO is completely integrated without need of external components. Variations in the VCO centre frequency are calibrated out automatically.

5.4 Bluetooth controller V1.2 and V2.0 + EDR features

The Bluetooth controller is backward compatible with the Bluetooth specification V1.2 [] and V2.0 + EDR []. Here below is a list with the main features of those specifications:

- Adaptive Frequency Hopping (AFH): hopping kernel, channel assessment as Master and as Slave
- Fast Connection: Interlaced scan for Page and Inquiry scan, answer FHS at first reception, RSSI used to limit range
- Extended SCO (eSCO) links: supports EV3, EV4 and EV5 packets
- Channel Quality Driven Data Rate change (CQDDR)
- QoS Flush
- Synchronization: BT clocks are available at HCI level for synchronization of parallel applications on different Slaves
- L2CAP Flow & Error control
- LMP SCO handling
- 2 Mbps packet types
 - ACL: 2-DH1, 2-DH3, 2-DH5
 - eSCO: 2-EV3, 2-EV5
- 3 Mbps packet types
 - ACL: 3-DH1, 3-DH3, 3-DH5
 - eSCO: 3-EV3, 3-EV5

5.5 Bluetooth controller V2.1 + EDR (“Lisbon”)

- Encryption Pause/Resume (EPR)
- Extended Inquiry Response (EIR)
- Link Supervision Time Out (LSTO)
- Secure Simple Pairing
- Sniff Subrating
- Quality of Service (Qos)
 - Packet Boundary Flag
 - Erroneous Data Delivery

5.6 Processor and memory

- ARM7TDMI
- On chip RAM, including provision for patches
- On chip ROM, preloaded with SW up to HCI

5.7 TX output power control

The STA2500D supports output power control with advanced features:

- Basic feature:
 - With the standard TX power control algorithm enabled, the STA2500D will adapt its output power when a remote BT device supports the RSSI feature; this allows the remote device to measure the link strength and to request the STA2500D to decrease/increase its output power. In case the remote device does not support the RSSI feature, the STA2500D will use its 'default' output power level.
- Advanced features, available via specific HCI commands:
 - Enhanced power control feature: allows the STA2500D to decrease autonomously its output power until the remote BT device, supporting the RSSI feature, requests to increase the output power.

6 General specification

All the values are provided according to the Bluetooth specification V2.1 + EDR ("Lisbon") unless otherwise specified. The below values are preliminary and will be updated in the next version of this datasheet.

6.1 Receiver

All specifications below are given at device pin level and with the conditions as specified. Parameters are given for each of the 3 modulation types supported.

Typical is defined at $T_{amb} = 25\text{ }^{\circ}\text{C}$, $BT_HV = 2.75\text{ V}$. Minimum and Maximum are worst cases over corner lots and temperature. Parameters are given at device pin, except for receiver interferers measured at antenna with a filter having a typical attenuation of 2.3 dB.

Table 15. Mbps receiver parameters - GFSK

Symbol	Parameter	Test condition	Min.	Typ.	Max.	Unit
RFin	Input frequency range	-	2402	-	2480	MHz
RXsensC	Receiver sensitivity (Clean transmitter)	@ BER 0.1%	-	-88	-86	dBm
RXsensD	Receiver sensitivity (Dirty transmitter)	@ BER 0.1%	-	-87	-84	dBm
RXmax	Maximum useable input signal level	@ BER 0.1%	-	10	15	dBm
Receiver blocking performance @ BER 0.1% on Channel 58 (without Filter)						
-	signal in GSM band 900 MHz (824 MHz to 960 MHz)	@ Input signal strength = -67 dBm	-	-15	-	dBm
-	signal in GSM band 1800 MHz (1805 MHz to 1990 MHz)	@ Input signal strength = -67 dBm	-	-2.5	-	dBm
-	signal in WCDMA band (2010 MHz to 2170 MHz)	@ Input signal strength = -67 dBm	-	-1.5	-	dBm
Receiver interferer performance @ BER 0.1%						
$C/I_{co-channel}$	Co-channel interference	@ Input signal strength = -60 dBm	-	9.5	11	dB
C/I_{1MHz}	Adjacent (± 1 MHz) interference	@ Input signal strength = -60 dBm	-	-9	0	dB
C/I_{+2MHz}	Adjacent (+2 MHz) interference	@ Input signal strength = -60 dBm	-	-40	-30	dB
C/I_{-2MHz}	Adjacent (-2 MHz) interference	@ Input signal strength = -67 dBm	-	-26	-9	dB
C/I_{+3MHz}	Adjacent (+3 MHz) interference	@ Input signal strength = -67 dBm	-	-46.5	-40	dB

Table 15. Mbps receiver parameters - GFSK (continued)

Symbol	Parameter	Test condition	Min.	Typ.	Max.	Unit
$C/I_{-3\text{MHz}}$	Adjacent (-3 MHz) interference	@ Input signal strength = -67 dBm	-	-43	-20	dB
$C/I_{\geq 4\text{MHz}}$	Adjacent ($\geq \pm 4$ MHz) interference	@ Input signal strength = -67 dBm	-	-48	-40	dB
Receiver inter-modulation						
IMD	Inter-modulation	Measured as defined in BT test specification [].	-39	-32	=	dBm

Typical is defined at $T_{\text{amb}} = 25\text{ }^{\circ}\text{C}$, $BT_HV = 2.75\text{ V}$. Minimum and Maximum are worst cases over corner lots and temperature. Parameters are given at device pin, except for receiver interferers measured at antenna with a filter having a typical attenuation of 2.3 dB.

Table 16. Mbps receiver parameters - $\pi/4$ -DQPSK

Symbol	Parameter	Test condition	Min.	Typ.	Max.	Unit
RFin	Input frequency range	=	2402		2480	MHz
RXsensC	Receiver sensitivity (Clean transmitter)	@ BER 0.01%	-	-87	-85	dBm
RXsensD	Receiver sensitivity (Dirty transmitter)	@ BER 0.01%	-	-86.5	-84.5	dBm
RXmax	Maximum useable input signal level	@ BER 0.1%	-15	-9	-	dBm
Receiver blocking performance @ BER 0.1% on channel 58 (without Filter)						
-	signal in GSM band 900 MHz (824 MHz to 960 MHz)	@ Input signal strength = -67 dBm	-	-15.5	-	dBm
-	signal in GSM band 1800 MHz (1805 MHz to 1990 MHz)	@ Input signal strength = -67 dBm	-	-3.5	-	dBm
-	signal in WCDMA band (2010 MHz to 2170 MHz)	@ Input signal strength = -67 dBm	-	-2.5	-	dBm
Receiver interferer performance @ BER 0.1%						
$C/I_{\text{co-channel}}$	Co-channel interference	@ Input signal strength = -60 dBm	-	11	13	dB
$C/I_{1\text{MHz}}$	Adjacent (± 1 MHz) interference	@ Input signal strength = -60 dBm	-	-11.5	0	dB
$C/I_{+2\text{MHz}}$	Adjacent (+2 MHz) interference	@ Input signal strength = -60 dBm	-	-40	-30	dB
$C/I_{-2\text{MHz}}$	Adjacent (-2 MHz) interference	@ Input signal strength = -67 dBm	-	-20	-7	dB
$C/I_{+3\text{MHz}}$	Adjacent (+3 MHz) interference	@ Input signal strength = -67 dBm	-	-48.5	-40	dB

Table 16. Mbps receiver parameters - $\pi/4$ -DQPSK (continued)

Symbol	Parameter	Test condition	Min.	Typ.	Max.	Unit
C/I_{-3MHz}	Adjacent (-3 MHz) interference	@ Input signal strength = -67 dBm	-	-47	-20	dB
$C/I_{\geq 4MHz}$	Adjacent ($\geq \pm 4$ MHz) interference	@ Input signal strength = -67 dBm	-	-48	-40	dB

Typical is defined at $T_{amb} = 25\text{ }^{\circ}\text{C}$, $BT_HV = 2.75\text{ V}$. Minimum and Maximum are worst cases over corner lots and temperature. Parameters are given at device pin, except for receiver interferers measured at antenna with a filter having a typical attenuation of 2.3 dB.

Table 17. Mbps receiver parameters - 8-DPSK

Symbol	Parameter	Test condition	Min.	Typ.	Max.	Unit
RFin	Input frequency range	-	2402	-	2480	MHz
RXsensC	Receiver sensitivity (Clean transmitter)	@ BER 0.01%	-	-79.5	-77.5	dBm
RXsensD	Receiver sensitivity (Dirty transmitter)	@ BER 0.01%	-	-77	-74.5	dBm
RXmax	Maximum useable input signal level	@ BER 0.1%	-20	-15	-	dBm
Receiver blocking performance @ BER 0.1% on channel 58 (without Filter)						
-	Signal in GSM band 900 MHz (824 MHz to 960 MHz)	@ Input signal strength = -67 dBm	-	-20	-	dBm
-	Signal in GSM band 1800 MHz (1805 MHz to 1990 MHz)	@ Input signal strength = -67 dBm	-	-14.5	-	dBm
-	Signal in WCDMA band (2010 MHz to 2170 MHz)	@ Input signal strength = -67 dBm	-	-14	-	dBm
Receiver interferer performance @ BER 0.1%						
$C/I_{co-channel}$	Co-channel interference	@ Input signal strength = -60 dBm	-	19	21	dB
C/I_{1MHz}	Adjacent (± 1 MHz) interference	@ Input signal strength = -60 dBm	-	-4	5	dB
C/I_{+2MHz}	Adjacent (+2 MHz) interference	@ Input signal strength = -60 dBm	-	-37	-25	dB
C/I_{-2MHz}	Adjacent (-2 MHz) interference	@ Input signal strength = -67 dBm	-	-12	0	dB
C/I_{+3MHz}	Adjacent (+3 MHz) interference	@ Input signal strength = -67 dBm	-	-46	-33	dB
C/I_{-3MHz}	Adjacent (-3 MHz) interference	@ Input signal strength = -67 dBm	-	-40	-13	dB
$C/I_{\geq 4MHz}$	Adjacent ($\geq \pm 4$ MHz) interference	@ Input signal strength = -67 dBm	-	-43	-33	dB

6.2 Transmitter

Unless otherwise stated, typical is defined at $T_{amb} = 25\text{ °C}$, $BT_HV = 2.75\text{ V}$. Minimum and Maximum are worst cases over corner lots and temperature. Parameters are given at device pin, except for in-band spurious measured at antenna.

Table 18. Transmitter parameters

Symbol	Parameter	Test condition	Min.	Typ.	Max.	Unit
RFout	Output frequency range	-	2402	-	2480	MHz
RF Transmit Power						
TXpout (GFSK)	Maximum output power ⁽¹⁾	@ 2402 - 2480 MHz @ 25 °C	6	8	10	dBm
TXpout (GFSK)	Maximum output power ⁽¹⁾	@ 2402 - 2480 MHz @ worst cases over corner lots and temperature	4.5	8	10.5	dBm
TXpout (GFSK)	Minimum output power	@ 2402 - 2480 MHz	-52.5	-47.5	-42.5	dBm
TXpout ($\pi/4$ -DQPSK)	Maximum output power ^{(1) (2)}	@ 2402 - 2480 MHz @ 25 °C	3.5	6	8	dBm
TXpout ($\pi/4$ -DQPSK)	Minimum output power ⁽²⁾	@ 2402 - 2480 MHz	-43.5	-38.5	-33.5	dBm
TXpoutrel ($\pi/4$ -DQPSK)	Relative transmit power ⁽³⁾	@ 2402 - 2480 MHz	-	-0.2	-	dB
TXpout (8-DPSK)	Maximum output power ^{(1) (2)}	@ 2402 - 2480 MHz @ 25 °C	3.5	6	8	dBm
TXpout (8-DPSK)	Minimum output power ⁽²⁾	@ 2402 - 2480 MHz	-43.5	-38.5	-33.5	dBm
TXpoutrel (8-DPSK)	Relative transmit power ⁽³⁾	@ 2402 - 2480 MHz	-	-0.2	-	dB
In-band spurious emission⁽⁴⁾						
FCC	FCC's 20 dB BW	-	900	930	950	kHz
ACP_2	Channel offset = ± 2 MHz	-	-	-43.5	-20	dBm
ACP_3	Channel offset = ± 3 MHz	-	-	-52.5	-40	dBm
ACP_4	Channel offset $\geq \pm 4$ MHz	-	-	-54.5	-40	dBm
EDR_IBS_1	Channel offset = ± 1 MHz (2 and 3 Mbps)	-	-	-33.5	-26	dB
EDR_IBS_2	Channel offset = ± 2 MHz (2 and 3 Mbps)	-	-	-31.5	-20	dBm
EDR_IBS_3	Channel offset = ± 3 MHz (2 and 3 Mbps)	-	-	-45	-40	dBm
EDR_IBS_4	Channel offset = ± 4 MHz (2 and 3 Mbps)	-	-	-50	-40	dBm

Table 18. Transmitter parameters (continued)

Symbol	Parameter	Test condition	Min.	Typ.	Max.	Unit
Initial carrier frequency tolerance (for an exact reference)⁽⁵⁾						
ΔF	f_TX-f0	-	-	0	-	kHz
Carrier frequency stability⁽⁶⁾						
Δf_{sl}	Carrier frequency stability	-	-	3.2	10	kHz
Carrier frequency drift⁽⁷⁾						
Δf_{p1l}	One slot packet	-	-	12	25	kHz
Δf_{p3l}	Three slots packet	-	-	14	40	kHz
Δf_{p5l}	Five slots packet	-	-	14	40	kHz
Carrier frequency drift rate⁽⁷⁾						
$\Delta f/50\mu s$	Frequency drift rate	-	-	8/50	20/50	kHz/ μs
Modulation accuracy ⁽⁶⁾ ⁽⁷⁾ ⁽⁸⁾						
$\Delta f1_{avg}$	Maximum modulation	-	140	163	175	kHz
$\Delta f2_{max}$	Minimum modulation	-	115	135	-	kHz
$\Delta f1_{avg}/\Delta f2_{avg}$		-	0.8	0.9	-	
-	2-DH5 RMS DEVM	-	-	8	20	%
-	2-DH5 99% DEVM	-	-	-	30	%
-	2-DH5 Peak DEVM	-	-	21	35	%
-	3-DH5 RMS DEVM	-	-	8	13	%
-	3-DH5 99% DEVM	-	-	-	20	%
-	3-DH5 Peak DEVM	-	-	21	25	%
TX out of band emission						
E850	Emission in GSM band 850 MHz	BW = 200 kHz ⁽⁷⁾ ⁽⁹⁾ ⁽¹⁰⁾	-	-79	-76	dBm
E900	Emission in GSM band 900 MHz	BW = 200 kHz ⁽⁷⁾ ⁽⁹⁾ ⁽¹⁰⁾	-	-79	-76	dBm
E1500	Emission in GPS band	BW = 200 kHz ⁽⁷⁾ ⁽⁹⁾ ⁽¹⁰⁾	-	-85	-84	dBm
E1800	Emission in GSM band 1800 MHz	BW = 200 kHz ⁽⁷⁾ ⁽⁹⁾ ⁽¹⁰⁾	-	-87	-84	dBm
E1900	Emission in GSM band 1900 MHz	BW = 200 kHz ⁽⁷⁾ ⁽⁹⁾ ⁽¹⁰⁾	-	-87	-84	dBm
Ewcdma	Emission in WCDMA band	BW = 3.8 MHz ⁽⁷⁾ ⁽⁹⁾ ⁽¹⁰⁾	-	-78	-75	dBm

1. Lower transmit power (i.e. Class 2) can be obtained by programming the radio init power table via software parameter download or an HCI command.
2. Power of GFSK part.
3. Relative power of EDR part compared to the GFSK part.
4. At antenna with maximum output power, filter attenuation of 2.3 dB.
5. Phase noise will add maximum [-10 kHz;10 kHz] for worst case clock 270 mVpp at 13 MHz.
6. Worst case clock 270 mVpp at 13 MHz. Measurement according to EDR RF test spec V2.0.E.3 [].
7. With maximum output power (BR or EDR).
8. Measured on reference design STLC2555_rev1.1 following eBOM and layout recommendations.
9. Measurement bandwidth.
10. Transmitting DH5 packets.

6.3 Class 1 operation

The STA2500D supports operation at Class 1 output power levels with the use of an external PA. The operation of the external PA and antenna switch are controlled by the following signals:

Table 19. Output power: class 1 control signals

Control signal name	Function
PAEN	PA enable (active during TX slot)
PA_VAL0	Bit 0 of the power level delivered by the PA
PA_VAL1	Bit 1 of the power level delivered by the PA
RXEN	LNA enable (if present)
AntSw	Control of the antenna switch
edr_mode	Indication to PA whether TX is EDR or BR

If Class 1 functionality is enabled through SW parameter download, then these 6 control signals are available on the pins as indicated in [Table 20](#) and [Table 21](#).

Table 20. Output power: class 1 device pin configuration (depending on SW parameter download)

Function	SW configuration 1	SW configuration 2
PAEN	BT_HOST_WAKEUP	BT_GPIO_16
PA_VAL0	BT_GPIO_0	BT_GPIO_10
PA_VAL1	BT_CLK_REQ_IN_1	BT_GPIO_9
RXEN	BT_CLK_REQ_IN_2	BT_GPIO_8
AntSw	(BT_GPIO_11)	BT_GPIO_11

Table 21. Output power: class 1 device pin configuration (depending on SW parameter download)

Function	SW configuration a	SW configuration b	SW configuration c
edr_mode	BT_CLK_REQ_OUT_1	BT_CLK_REQ_OUT_2	not available on a pin

Configuration 2 allows to deploy the STA2500D in Class 1 mode, still maintaining the necessary control signals to coexist and cooperate with a WLAN transceiver. The handshake between the STA2500D and a WLAN device happens in this case through other BT_GPIO pins.

6.4 Power-up

The BT_RESETN pin should be active while powering up BT_VDD_HV and should stay active at least two cycles of the low power clock (BT_LP_CLK) after power-up is completed.

The time between the STA2500D making BT_CLK_REQ_OUT_x active and the platform providing a stable clock should maximally be 15 ms.

6.5 System clock

The STA2500D works with a sine wave or digital clock provided on the BT_REF_CLK_IN pin. Detailed specifications are found in [Section 2.4](#).

6.6 Low power clock

The low power clock is used by the Bluetooth Controller as reference clock during the low power modes. It requires an accuracy of ± 250 ppm. The STA2500D requires a digital clock to be provided on the BT_LP_CLK pin, with frequencies of 3.2 kHz, 32 kHz and 32.768 kHz.

After power-up, the low power clock must be available before the reset is released. It must remain active all the time until the STA2500D is powered off.

6.7 Clock detection

An integrated automatic detection algorithm detects the system and low power clock frequencies after a hardware reset. The steps in the clock detection routine are:

- Identification of the system clock frequency (9.6 MHz, 10 MHz, 13 MHz, 16 MHz, 16.8MHz, 19.2 MHz, 26 MHz, 33.6 MHz or 38.4 MHz)
- Identification of the low power clock (3.2 kHz, 32.768 kHz or 32 kHz).

6.8 Clock request signals

To allow minimum power consumption, a clock request feature is available so that the system clock (BT_REF_CLK_IN) can be stopped when not needed by the Bluetooth system. The clock request signal can be active high or active low, and the STA2500D supports internal propagation of clock request signal coming from another device in the system.

Different configurations as described below are supported immediately after reset and in all Bluetooth operation modes, provided that BT_VIO_A is available.

The clock request functionality is based on four different signals: BT_CLK_REQ_OUT_1, BT_CLK_REQ_OUT_2, BT_CLK_REQ_IN_1, BT_CLK_REQ_IN_2, with the following function:

- BT_CLK_REQ_OUT_1: active low or high clock request, depending on HW configuration pins (Table). Support for either push-pull or open drain output.
- BT_CLK_REQ_OUT_2: active low clock request, only used in combination with SPI mode. Support for either push-pull or open drain output.
- BT_CLK_REQ_IN_1: active high clock request input from an other device, depending on HW configuration pin.
- BT_CLK_REQ_IN_2: active low clock request input from an other device.

The following modes are supported:

- Active high clock request input and output combined with UART or SPI:

Figure 3. Active high clock request input and output combined with UART or SPI

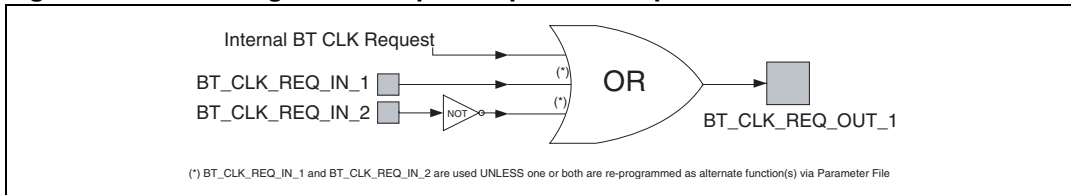

- Active low clock request input and output combined with UART:

Figure 4. Active low clock request input and output combined with UART

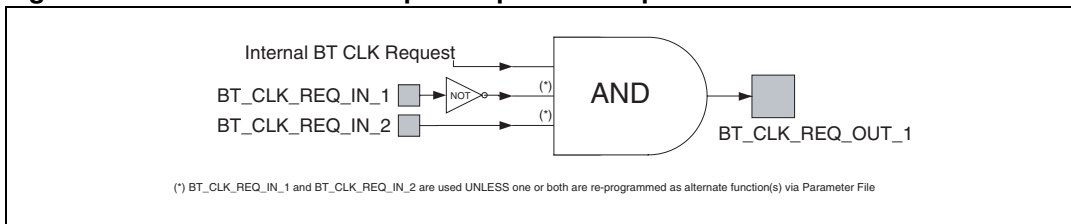

- Active low clock request input and output combined with SPI:

Figure 5. Active low clock request input and output combined with SPI

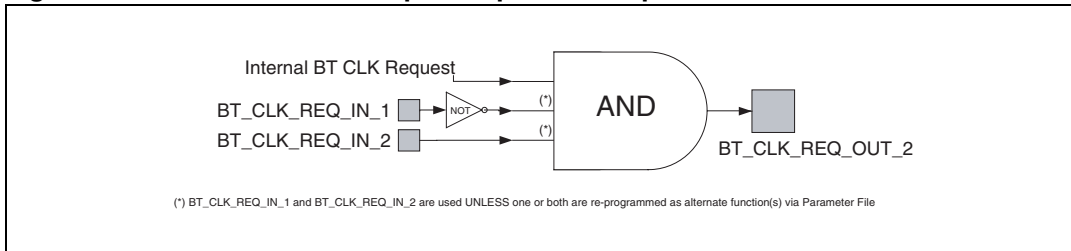

Table 22. Use of the BT_CLK_REQ_IN and BT_CLK_REQ_OUT signals in different modes

BT_CONFIG_1	BT_CONFIG_2	BT_CONFIG_3	Protocol	BT_CLK_REQ_IN_1	BT_CLK_REQ_IN_2	BT_CLK_REQ_OUT_1	BT_CLK_REQ_OUT_2
0	1	0	H4 UART	Active high ⁽¹⁾	Active low ⁽¹⁾	Active high	not used
0	1	1	H4 UART	Active low ⁽¹⁾	Active low ⁽¹⁾	Active low	not used
1	0	1	Enhanced H4 SPI	Active high	Active low	Active high	Active low

1. BT_CLK_REQ_IN_1 and BT_CLK_REQ_IN_2 are used in the configuration logic, UNLESS one or both I/Os re-programmed as alternate function(s) via the Parameter File.

The pins which are “not used” are available for alternate functions as described in [Section 7.5](#).

6.9 Interrupts

The user can program the BT_GPIOs as external interrupt sources.

6.10 Low power modes

6.10.1 Overview

To save power, three low power modes are supported as described in [Table 23](#).

Depending of the Bluetooth and of the Host's activity, the STA2500D decides to use Sleep mode or Deep Sleep mode. Note however that the Deep Sleep mode must first be activated via SW parameter download or an HCI command prior to any possibility to use it as the default configuration is only Sleep mode. Complete Power Down is entered only after an explicit command from the Host.

Table 23. Low power modes

Low power mode	Description
Sleep mode	The STA2500D: <ul style="list-style-type: none"> – Accepts HCI commands from the Host. – Supports all types of Bluetooth links. – Can transfer data over Bluetooth links. – Dynamically switches between sleep and active mode when needed. – The system clock is still active in part of the design. – Parts of the chip are dynamically powered off depending on the Bluetooth activity.
Deep Sleep mode	The STA2500D: <ul style="list-style-type: none"> – Does not accept HCI commands from the Host. – Supports Page and Inquiry scans. – Supports Bluetooth links that are in Sniff or Sniff Subrating. – Dynamically switches between Deep Sleep and active mode during Bluetooth activity. The Deep Sleep mode entry is initiated by the Host, the STA2500D acknowledges or not. The wake-up mechanism must be enabled by a SW parameter download before it can be used. More details in section 6.10.3. – The system clock is not active in any part of the design. – Parts of the chip are dynamically powered off depending on the Bluetooth activity.
Complete Power Down	The STA2500D is effectively powered down: <ul style="list-style-type: none"> – No Bluetooth activity is supported. – The HCI interface is shut down. – The system clock is not active in any part of the design. – Most parts of the chip are completely powered off. – RAM content is not maintained (initialisation is required at wake-up). – Some pins (UART/SPI I/Os and the 4 clock request signals and BT_GPIO_16) keep their previous configuration (input or output, pull behaviour) during Completed Power Down. – The Complete Power Down entry is initiated by an HCI command followed by a Deep Sleep command, this in order to ensure a smooth transition from active to Complete Power Down state. In order to go out of this mode, either a HW reset or BT_WAKEUP = '1' is needed.

6.10.2 Some examples for the usage of the low power modes

Sniff or sniff subrating

The STA2500D is in active mode with a Bluetooth connection. Once the transmission is concluded, Sniff or Sniff Subrating is programmed. When one of these two states is entered, the STA2500D goes into Sleep mode. After that, the Host may decide to place the STA2500D in Deep Sleep mode as described in [Section 6.10.3](#). The Deep Sleep mode allows for lower power consumption. When the STA2500D needs to send or receive a packet (e.g. at T_{sniff} or at the beacon instant), the STA2500D requests the system clock and enters active mode for the needed transmission/reception. Immediately afterwards, the STA2500D will go back to Deep Sleep mode. If some HCI transmission is needed, the UART/SPI link will be reactivated, using one of the four ways explained in [Section 6.10.3](#) and the STA2500D will move from Deep Sleep mode to Sleep mode.

Inquiry/page scan

When only Inquiry scan or Page scan is enabled, the STA2500D will go in Sleep mode or Deep Sleep mode outside the receiver activity. The selection between Sleep mode and Deep Sleep mode depends on the UART/SPI activity as in Sniff or Sniff Subrating.

No connection

If the Host allows Deep Sleep mode (as described in [Section 6.10.3](#)) and there is no activity, then the STA2500D puts itself in Deep Sleep mode. It is possible to exit the Deep Sleep mode by using one of the four methods explained in [Section 6.10.3](#). In this Deep Sleep mode (no connection), the Host can also decide to put the STA2500D in Complete Power Down to further reduce the power consumption. In this case some part of the STA2500D will be completely powered off. The request to quit the Complete Power Down is done either by putting the BT_WAKEUP signal to '1' or with an HW reset.

Active link

When there is an active link ((e)SCO or ACL), the Bluetooth Controller will not go in Deep Sleep mode and not in Complete Power Down. But the Bluetooth Controller is made in such a way that whenever it is possible, depending on the scheduled activity (number of link, type of link, amount of data exchanged), it goes in Sleep mode.

6.10.3 Deep sleep mode entry and wake-up

During periods of no activity on the Bluetooth and on the Host side, the chip can be placed in Deep Sleep mode. Four ways to initiate Deep Sleep mode and to wake up are supported (selection is done through software parameter download): they are respectively based on a UART interface in the first case, an SPI interface in the second case and third case, while either UART or SPI interfaces can be used in the fourth case that is based on an handshake mechanism.

Deep sleep mode entry and wake up through H4 UART

It requires BT_CLK_REQ_OUT_1, BT_UART_RXD and BT_UART_RTS. The BT_UART_RXD is used as wake-up signal from the Host, the BT_CLK_REQ_OUT_1 requires the clock from the Host and the BT_UART_RTS indicates when the STA2500D is

available. In this mode, the break function (BT_UART_RXD is low for more than 1 word) is used to distinguish between normal operation and low power mode usage.

- **Deep sleep mode entry**

The Host tells the STA2500D that it can go in Deep Sleep mode power by forcing the BT_UART_RXD of the STA2500D to '0' for more than 1 word. The STA2500D decides to go in Deep Sleep mode, or not, depending on its scheduled activity and on the number of events or data packets to be sent to the Host. In case it decides to go in Deep Sleep mode, it signals it by forcing BT_UART_RTS high; then it asserts BT_CLK_REQ_OUT_1 low to tell the Host that it does not need the clock anymore. The STA2500D cannot go in Deep Sleep mode by itself. This is a logical consequence of the fact that the system clock is needed to receive characters on the UART. Note that when the system is in Deep Sleep mode, the UART is closed.

- **Deep sleep mode wake-up**

The wake-up procedure can be initiated by the Host or by the STA2500D. In the latter case, it can be with or without communication, depending if there are data to be transmitted to the Host.

1. *Wake-up initiated by the Host*

The Host sets the BT_UART_RXD pin of the STA2500D to '1'. Then the STA2500D asks the Host to restart the system clock by setting BT_CLK_REQ_OUT_1 to '1'. When the clock is available, the STA2500D confirms it is awake by releasing BT_UART_RTS to '0'.

2. *Autonomous wake-up with UART communication (i.e. initiated by the STA2500D)*

The STA2500D first asks the Host to restart the system clock by setting BT_CLK_REQ_OUT_1 to '1'.

When the clock is available, the STA2500D sets BT_UART_RTS low, and then the Host can give confirmation by releasing the BT_UART_RXD of the STA2500D.

Another possibility is that the STA2500D sets BT_HOST_WAKEUP to '1' to request the Host attention. Then the Host can give confirmation by releasing the BT_UART_RXD of the STA2500D and the STA2500D sets BT_UART_RTS low.

The choice between the two possibilities is selected by a software parameter.

3. *Autonomous wake-up without UART communication (i.e. initiated by the STA2500D)*

The STA2500D asks the Host to restart the system clock by setting BT_CLK_REQ_OUT_1 to '1'.

Figure 6. Deep sleep mode entry and wake-up through H4 UART

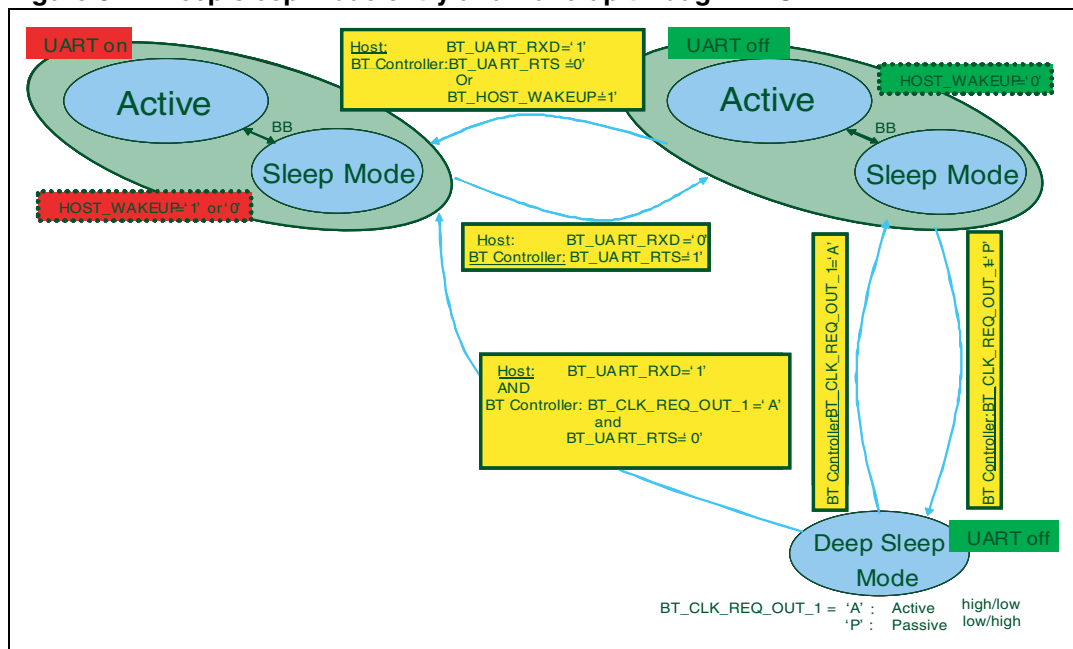

Deep sleep mode entry and wake-up through enhanced H4 SPI

In this case no additional signals are needed to control the Deep Sleep mode and the wake-up mechanism except for $BT_CLK_REQ_OUT_x$ ($BT_CLK_REQ_OUT_1$ for active high polarity and $BT_CLK_REQ_OUT_2$ for active low polarity).

The enhanced H4 protocol makes use of three messages: SLEEP, WAKEUP and WOKEN. More details on the enhanced H4 protocol can be found in [Section 8.2](#).

- **Deep sleep mode entry**

Entering Deep Sleep mode can only be initiated by the Host sending a SLEEP message to the Bluetooth Controller.

If that one accepts it, the device enters Deep Sleep mode: consequently the Bluetooth Controller de-asserts $BT_CLK_REQ_OUT_x$ and internally gates the system clock. This is illustrated in [Figure 7](#).

If there is still pending activity at the Bluetooth side on the air, the Bluetooth Controller does not immediately enter Deep Sleep mode and therefore $BT_CLK_REQ_OUT_x$ stays 'active' during this period: however the Bluetooth Controller will go in Deep Sleep mode at the end of the air activity.

If there is pending data to be transferred to the Host, the Bluetooth Controller will request a data transfer: however the Bluetooth Controller will go in Deep Sleep mode at the end of the data transfer.

- **Deep sleep mode wake-up**

Wake-up can be requested by the Host or autonomously by the Bluetooth Controller. In the latter case, it can be with or without communication on the interface (i.e. during Page scan, there is no data to transfer to the Host).

1. *Wake-up initiated by the Host*

In the case of a wake-up by the Host, it sends a WAKEUP command and waits for a WOKEN response before starting the data exchange. Of course the Bluetooth Controller must first request the system clock through $BT_CLK_REQ_OUT_x$. It should be noted that the WAKEUP message is decoded in the Bluetooth Controller's

SPI HW block even before the system clock is available. This block will generate an interrupt, allowing the Bluetooth Controller to reply with a WOKEN message. This is illustrated in *Figure 8*.

2. *Autonomous wake-up with communication (i.e. initiated by the STA2500D)*
 In the case of an autonomous wake-up with data transmission, the Bluetooth Controller sets BT_SPI_INT high to request the SPI interface and waits for BT_SPI_CSN going low, indicating the SPI transaction starts. Of course the Bluetooth Controller must first request the system clock through BT_CLK_REQ_OUT_x before being able to start the process. This is illustrated in *Figure 9*. Note that the Bluetooth Controller goes back to Deep Sleep mode at the end of the data transfer.
3. *Autonomous wake-up without communication (i.e. initiated by the STA2500D)*
 For autonomous wake-up without SPI communication, the STA2500D only asserts BT_CLK_REQ_OUT_x to get the system clock.

Figure 7. Entering deep sleep mode through enhanced H4 SPI

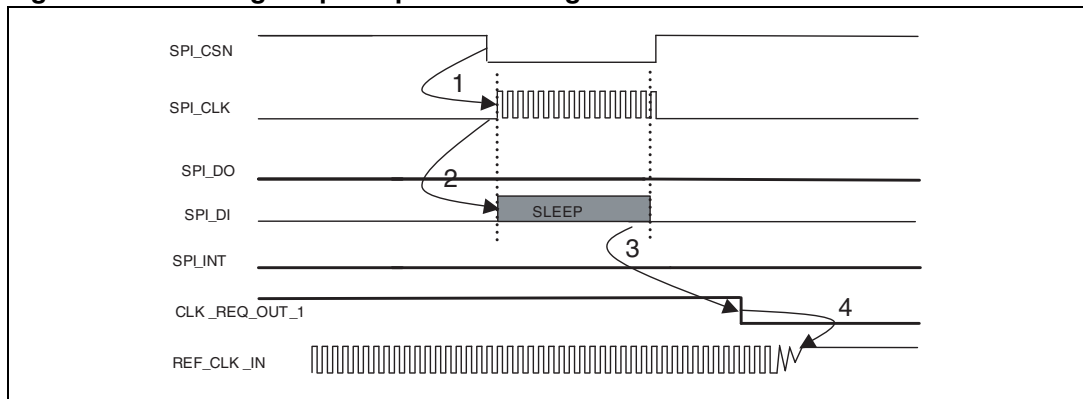

Figure 8. Wake-up by the host through enhanced H4 SPI

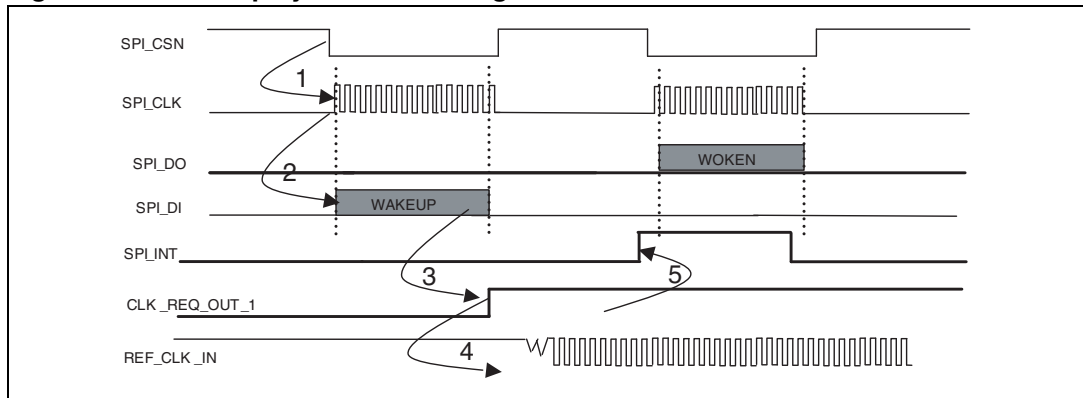
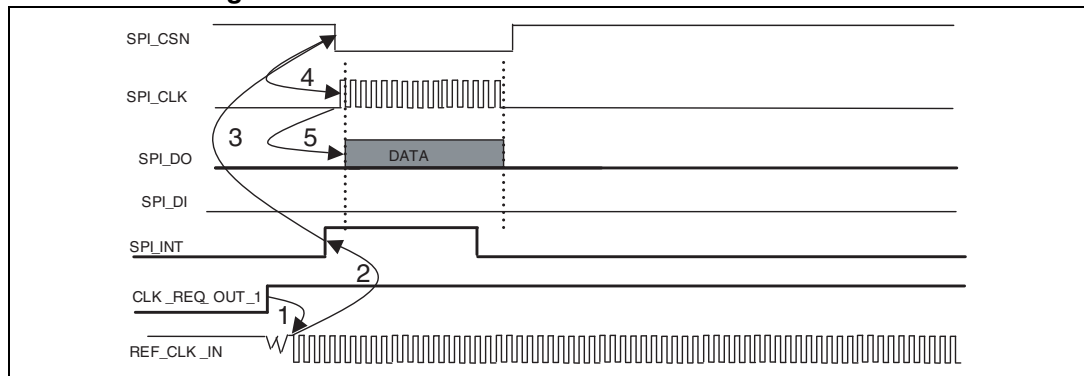

Figure 9. Wake-up by the Bluetooth controller with data transmission to the host, through enhanced H4 SPI



Deep sleep mode entry and wake-up through H4 SPI

It requires BT_CLK_REQ_OUT_x (BT_CLK_REQ_OUT_1 for active high polarity and BT_CLK_REQ_OUT_2 for active low polarity), BT_WAKEUP and BT_SPI_INT. The BT_WAKEUP is used as wake-up signal from the Host, the BT_CLK_REQ_OUT_x requires the clock from the Host and BT_SPI_INT is used as a wake-up signal from the Bluetooth Controller.

- **Deep sleep mode entry**

The Host tells the STA2500D that it can go in Deep Sleep mode by forcing the BT_WAKEUP of the STA2500D to '0'. The STA2500D decides to go in Deep Sleep mode, or not, depending on its scheduled activity and on the number of events or data packets to be sent to the Host. In case it decides to go in Deep Sleep mode, it asserts BT_CLK_REQ_OUT_x 'inactive' to tell the Host that it does not need the clock anymore. The STA2500D cannot go in Deep Sleep mode by itself. Note that the Host cannot force BT_WAKEUP to '0' before the end of a write operation from the Host, this in order to allow correct decoding of the message by the Bluetooth Controller.

- **Deep sleep mode wake-up**

The wake-up procedure can be initiated by the Host or by the STA2500D. In the latter case, it can be with or without communication, depending if there are data to be transmitted to the Host.

1. *Wake-up initiated by the Host*

The Host sets the BT_WAKEUP pin of the STA2500D to '1'. Then the STA2500D asks the Host to restart the system clock by setting BT_CLK_REQ_OUT_x to 'active'. When the clock is available and stable, the Host can use BT_SPI_CSN to start an SPI transaction if needed (there is a programmable minimum delay between the assertion of BT_CLK_REQ_OUT_x and the moment the Host can assert BT_SPI_CSN).

2. *Autonomous wake-up with SPI communication (i.e. initiated by the STA2500D)*

The STA2500D first asks the Host to restart the system clock by setting BT_CLK_REQ_OUT_x to 'active'. When the clock is available, the STA2500D sets BT_SPI_INT high to request the SPI interface to the Host and waits for BT_SPI_CSN going low, indicating the SPI transaction starts.

3. *Autonomous wake-up without SPI communication (i.e. initiated by the STA2500D)*

The STA2500D asks the Host to restart the system clock by setting BT_CLK_REQ_OUT_x to 'active'.

Figure 10. Deep sleep mode entry and wake-up through H4 SPI

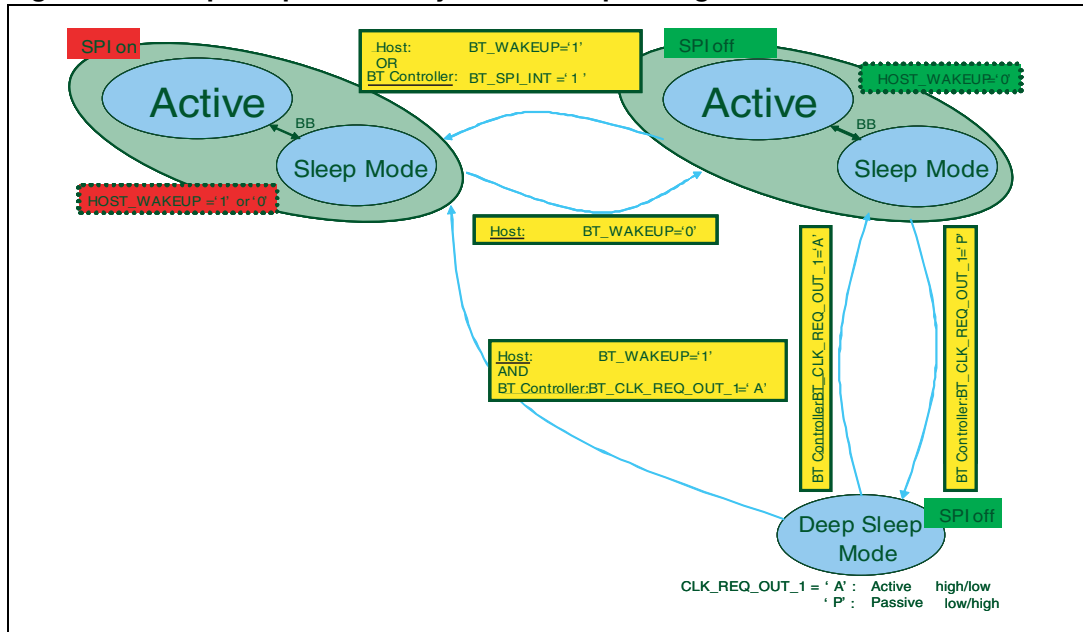

Deep sleep mode entry and wake-up through H4 UART or H4 SPI with handshake

This method is supported by both H4 UART and H4 SPI. The description below is for H4 UART.

It requires BT_CLK_REQ_OUT_1, BT_WAKEUP and BT_HOST_WAKEUP. The BT_WAKEUP is used as wake-up signal from the Host, the BT_CLK_REQ_OUT_1 requires the clock from the Host and BT_HOST_WAKEUP is used as a wake-up signal from the Bluetooth Controller.

- **Deep sleep mode entry**
 The Host tells the STA2500D that it can go in Deep Sleep mode by forcing the BT_WAKEUP of the STA2500D to '0'. The STA2500D decides to go in Deep Sleep mode, or not, depending on its scheduled activity and on the number of events or data packets to be sent to the Host. In case it decides to go in Deep Sleep mode, it asserts BT_CLK_REQ_OUT_1 low to tell the Host that it does not need the clock anymore. On the contrary, if it still wants the interface active for up-transmission, it keeps BT_HOST_WAKEUP to '1' as long as needed before de-asserting BT_CLK_REQ_OUT_1. This is illustrated in *Figure 11*.
- **Deep sleep mode wake-up**
 The wake-up procedure can be initiated by the Host or by the STA2500D. In the latter case, it can be with or without communication, depending if there are data to be transmitted to the Host.
 1. *Wake-up initiated by the Host*
 The Host sets the BT_WAKEUP pin of the STA2500D to '1'. Then the STA2500D asks the Host to restart the system clock by setting BT_CLK_REQ_OUT_1 to '1'. When the clock is available and stable, the STA2500D puts BT_UART_RTS low to allow communication. In case the STA2500D wants to send events to the Host, it then puts

BT_HOST_WAKEUP to '1' in order to warm the Host and traffic starts when the Host puts BT_UART_CTS to low. This is illustrated in *Figure 12*.

2. *Autonomous wake-up with communication (i.e. initiated by the STA2500D)*
 The STA2500D first asks the Host to restart the system clock by setting BT_CLK_REQ_OUT_1 to '1'.
 When the clock is available, the STA2500D requests traffic by asserting HOST_WAKEUP high. Then either it puts BT_UART_RTS low to start traffic exchange directly or it waits for the Host to first assert BT_WAKEUP high. The selection in between the two behaviours is done by a SW parameter in the Parameter File.
3. *An autonomous wake-up without communication (i.e. initiated by the STA2500D)*
 The STA2500D asks the Host to restart the system clock by setting BT_CLK_REQ_OUT_1 to '1'. The UART signals are not changing.

Figure 11. Entering deep sleep mode, pending data on UART interface, through UART with handshake

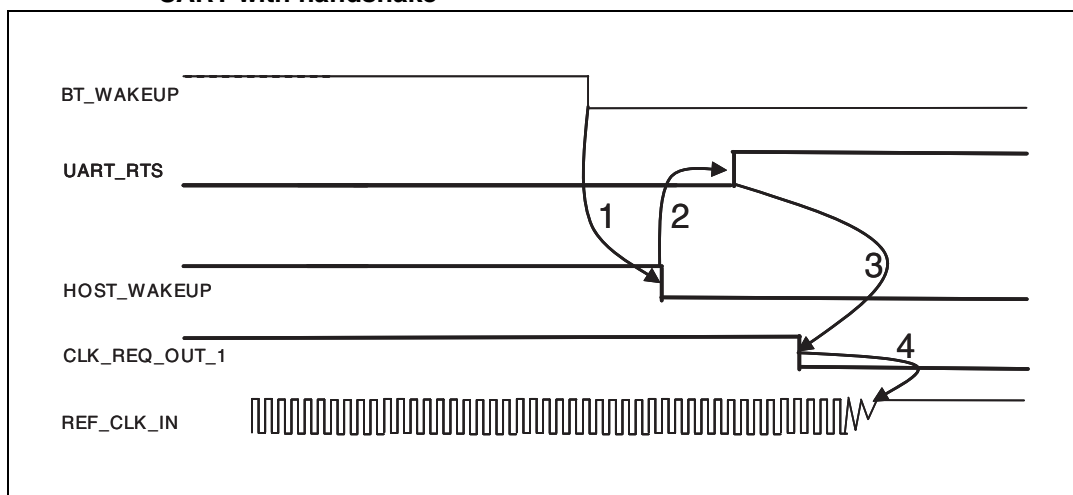

1. Host puts BT_WAKEUP low. BT Controller notices it. But as there is pending traffic to be send to Host, it keeps HOST_WAKEUP high as long as needed for up-transmission and then de-asserts HOST_WAKEUP, telling the Host there is nothing more to transmit.
2. BT Controller puts UART_RTS high to set "flow off". This is done in fixed number of instructions.
3. Then BT Controller puts CLK_REQ_OUT_1 to '0', telling the Host it can cut the clock. This is done in fixed number of instructions.
4. There is no clock, BT is in Deep Sleep mode.

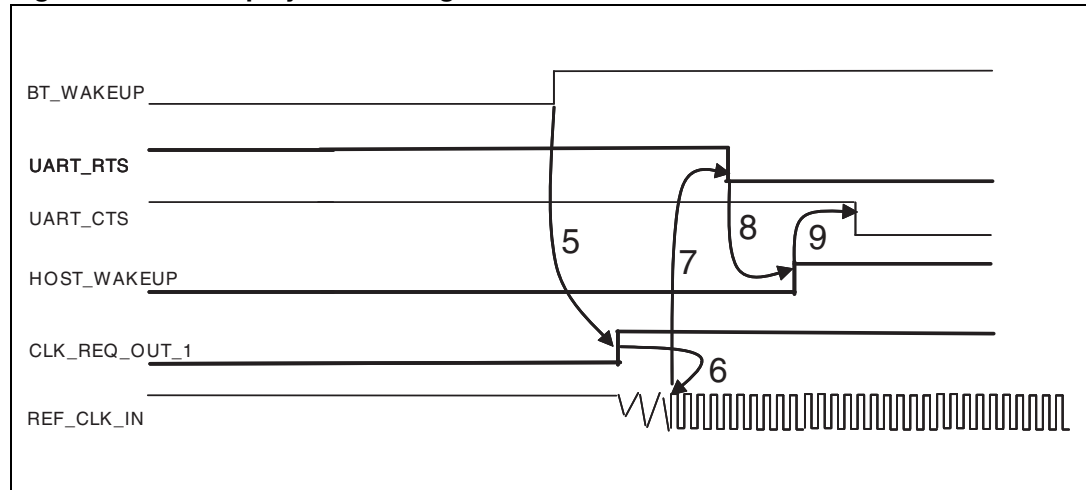
Figure 12. Wakeup by host through UART with handshake

5. Host pulls BT_WAKEUP high to wake-up BT Controller. HW starts driving CLK_REQ_OUT_1 high (after $2 * LP_CLK$).
6. Host starts 13 MHz clock and distribute it when stable. Delay between CLQ_REQ_OUT_1 and usage of stable clock is programmable in between 3 and 39 ms.
7. When BT Controller starts with clock, it sets “flow on” by putting UART_RTS low. There is a fixed SW latency. Host can send commands.
8. BT Controller sets HOST_WAKEUP high telling to the Host it has events to send to the Host.
9. When the Host is ready for data transmission, it asserts UART_CTS low.

6.11 Patch RAM

The STA2500D includes a HW block that allows patching of the ROM code.

Additionally, a SW patch mechanism allows replacing complete SW functions without changing the ROM image.

A part of the RAM memory is used for HW and SW patches.

6.12 Download of SW parameter file

To change the device configuration a set of customizable parameters have been defined and put together in one file, the parameter file. This Parameter File is downloaded at start-up into the STA2500D.

Examples of parameters are: radio configuration, PCM settings etc.

The same HCI command is used to download the file containing the patches (both those for the SW and HW mechanism).

A more detailed description of the SW parameter file is available upon request.

6.13 Bluetooth - WLAN coexistence in collocated scenario

The coexistence interface uses up to 4 WLAN control signal pins, which can be mapped via software parameter download on different pins of the STA2500D (see [Section 7.5](#)).

The functionality of the 4 WLAN control signal pins depends on the selected algorithm, as explained

below and summarized in [Table 24](#).

Bluetooth and WLAN 802.11 b/g [] [] technologies occupy the same 2.4 GHz ISM band. The STA2500D implements a set of mechanisms to avoid interference in a collocated scenario.

The STA2500D supports 5 different algorithms in order to provide efficient and flexible simultaneous functionality between the two technologies in collocated scenarios:

- **Algorithm 1:** PTA (Packet Traffic Arbitration) based coexistence algorithm defined in accordance with the IEEE 802.15.2 recommended practice [].
- **Algorithm 2:** the WLAN is the Master and it indicates to the STA2500D when not to operate in case of simultaneous use of the air interface.
- **Algorithm 3:** the STA2500D is the Master and it indicates to the WLAN chip when not to operate in case of simultaneous use of the air interface.
- **Algorithm 4:** Two-wire mechanism
- **Algorithm 5:** Alternating Wireless Medium Access (AWMA), defined in accordance with the WLAN 802.11 b/g [] [] technologies.

The algorithm is selected via an HCI command. The default algorithm is algorithm 1.

6.13.1 Algorithm 1: PTA (packet traffic arbitration)

The algorithm is based on a bus connection between the STA2500D and the WLAN chip:

Figure 13. PTA diagram

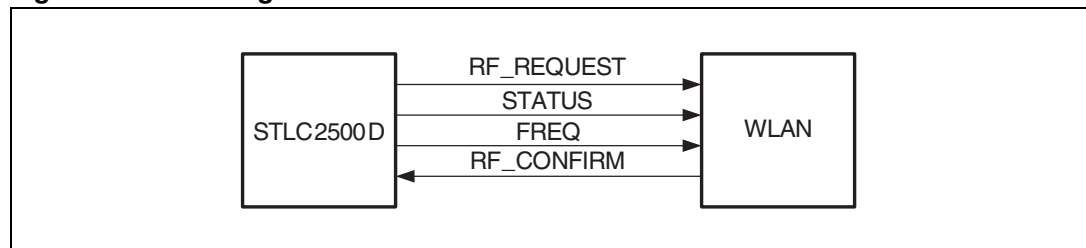

By using this coexistence interface it is possible to dynamically allocate bandwidth to the two devices when simultaneous operations are required while the full bandwidth can be allocated to one of them in case the other one does not require activity.

The algorithm involves

- a priority mechanism, which allows preserving the quality of certain types of link.
- a mechanism to indicate that a periodic communication is ongoing.

A typical application would be to guarantee optimal quality to the Bluetooth voice communication while an intensive WLAN communication is ongoing.

Several algorithms have been implemented in order to provide a maximum of flexibility and efficiency for the priority handling. ST specific HCI commands are implemented to select the algorithm and to tune the priority handling.

The combination of time division multiplexing and the priority mechanism avoids the interference due to packet collision. It also allows the maximization of the 2.4 GHz ISM bandwidth usage for both devices while preserving the quality of some critical types of link.

6.13.2 Algorithm 2: WLAN master

In case the STA2500D has to cooperate, in a collocated scenario, with a WLAN chip not supporting a PTA based algorithm, it is possible to put in place a simpler mechanism.

The interface is reduced to 1 line:

Figure 14. WLAN master

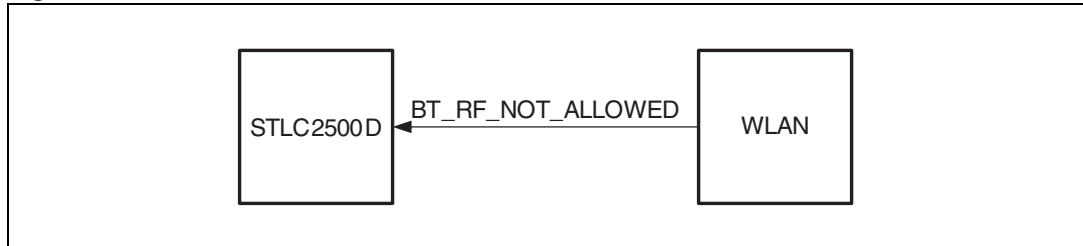

When the WLAN has to operate, it alerts high the BT_RF_NOT_ALLOWED signal and the STA2500D will not operate while this signal stays high.

This mechanism permits to avoid packet collision in order to make an efficient use of the bandwidth but cannot provide guaranteed quality over the Bluetooth links.

6.13.3 Algorithm 3: Bluetooth master

This algorithm represents the symmetrical case of algorithm 2. Also in this case the interface is reduced to 1 line:

Figure 15. Bluetooth master

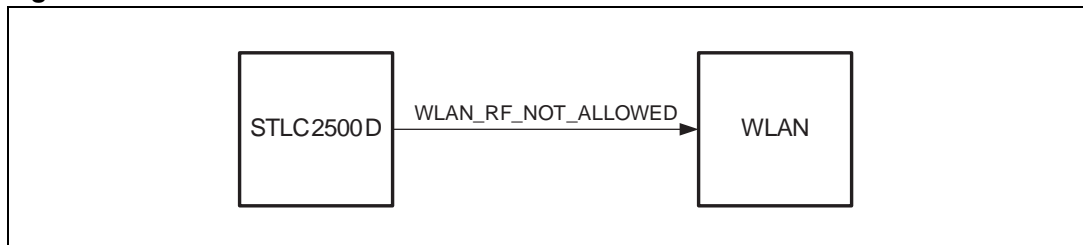

When the STA2500D has to operate it alerts high the WLAN_RF_NOT_ALLOWED signal and the WLAN will not operate while this signal stays high.

This mechanism permits to avoid packet collision in order to make an efficient use of the bandwidth, it provides high quality for all Bluetooth links but cannot provide guaranteed quality over the WLAN links.

6.13.4 Algorithm 4: two-wire mechanism

Based on algorithm 2 and 3, the Host decides, on a case-by-case basis, whether WLAN or Bluetooth is master. The Master role can be checked and changed at run-time by the Host via an HCI command.

6.13.5 Algorithm 5: Alternating wireless medium access (AWMA)

AWMA utilizes a portion of the WLAN beacon interval for Bluetooth operations. From a timing perspective, the medium assignment alternates between usage following WLAN procedures and usage following Bluetooth procedures.

The timing synchronization between the WLAN and the STA2500D is done by the HW signal MEDIUM_FREE.

Table 24. WLAN HW signal assignment

WLAN control signal (see also Table 28)	Scenario 1: PTA	Scenario 2: WLAN master	Scenario 3: BT master	Scenario 4:2-wire	Scenario 5: AWMA
WLAN 1	RF_CONFIRM	BT_RF_NOT_ALLOWED	Not used	BT_RF_NOT_ALLOWED	MEDIUM_FREE
WLAN 2	RF_REQUEST	Not used	WLAN_RF_NOT_ALLOWED	WLAN_RF_NOT_ALLOWED	Not used
WLAN 3	STATUS	Not used	Not used	Not used	Not used
WLAN 4	FREQ (optional)	Not used	Not used	Not used	Not used

7 Digital interfaces

7.1 The UART interface

The STA2500D contains a 4-pin (BT_UART_RXD, BT_UART_TXD, BT_UART_RTS, and BT_UART_CTS) UART compatible with 16450, 16550 and 16750 standards. It is running up to 4000 kbps (+1.5% / -1%).

The configuration is 8 data bits, 1 start bit, 1 stop bit, and no parity bit. The transmit and receive paths contain a DMA function for low CPU load and high throughput. Auto RTS/CTS is implemented in HW, controllable by SW.

The UART accepts all HCI commands as described in the Bluetooth specification, it supports H4 proprietary commands and the Deep Sleep mode entry and wake-up through H4 UART (see [Section : Deep sleep mode entry and wake up through H4 UART](#)). The complete list of supported proprietary HCI commands is available upon request.

At startup, the UART baud rate is fixed at 115200 bps independently of the BT_REF_CLK_IN frequency. A specific HCI command is provided to change the UART baud rate when necessary within the range 9600 bps to 4000 kbps. All standard baud rates and many other ones are supported.

7.2 The SPI interface

The physical SPI interface is made up of 5 signals: clock, chip select, data in, data out and interrupt. When the SPI mode is selected, these signals are available through the BT_UART/BT_SPI and BT_HOST_WAKEUP pins.

Figure 16. SPI interface

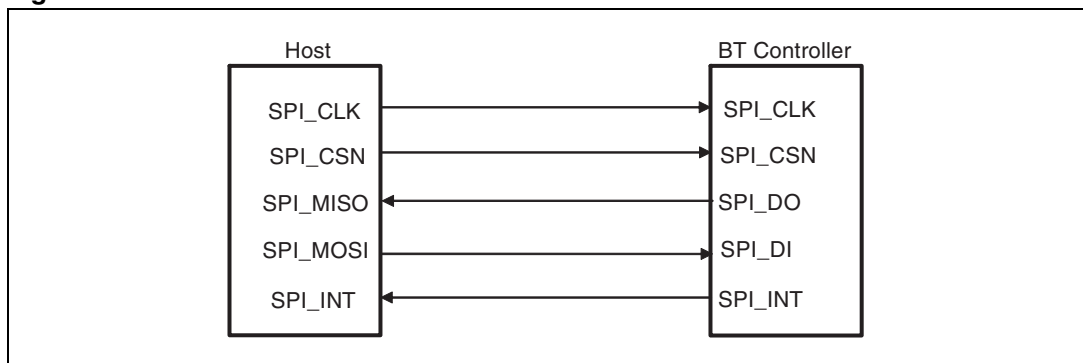

- SPI_CSN (on pin BT_UART_RTS/BT_SPI_CSN): chip select allows the use of multiple Slaves (1 chip select per Slave). This signal is active low. This signal is mandatory, even with only 1 Slave, because the Host must drive this signal to indicate SPI frames.
- SPI_CLK (on pin BT_UART_CTS/BT_SPI_CLK): clock signal, active for a multiple of data length cycles during an SPI transfer (SPI_CSN active). The clock is allowed to be active when SPI_CSN is not active, in order to serve other Slaves.
- SPI_DO (on pin BT_UART_TXD/BT_SPI_DO): data transfer from Slave to Master. Data is generated on the negative edge of SPI_CLK by the Slave and sampled on the

positive edge of SPI_CLK. When SPI_CSN is inactive, this BT Controller output is in tristate mode.

- SPI_DI (on pin BT_UART_RXD/BT_SPI_DI): data transfer from Master to Slave. Data is generated on the negative edge of SPI_CLK by the Master and sampled on the positive edge of SPI_CLK.
- SPI_INT (on pin BT_HOST_WAKEUP/BT_SPI_INT): interrupt from the Slave, used to request an SPI transfer by the Slave to the Master. The signal is active high (Host input must be level sensitive).

The SPI interface is Master at the Host side, and Slave at Bluetooth Controller side. It is designed to work with the H4 and enhanced H4 protocol. Also synchronous data packet transfer (eSCO) over HCI is supported.

The SPI data length and endianness are configurable.

The SPI interface can only operate in half duplex mode.

Also the use of flow control is configurable. The flow control consists of an indication from the Bluetooth Controller whether its receive buffers are ready to receive data. This indication is available in three ways:

- On the SPI_DO during T_{SCS} (time between SPI_CSN becoming active and SPI_CLK becoming high), see FC in [Figure 17](#) and Tscs in [Figure 18](#)
- In a register that can be read by the Host
- Optionally on one of the programmable GPIOs: GPIO_16. This is enabled by a SW parameter download, see [Section 7.5](#)

The default SPI configuration is:

- Half duplex mode
- 16 bit data length
- Most significant byte first
- Most significant bit first
- Flow control on SPI_DO and in a register

More detailed information on the SPI interface is available upon request.

Figure 17. SPI data transfer timing for data length of 8 bits and lsb first, full duplex

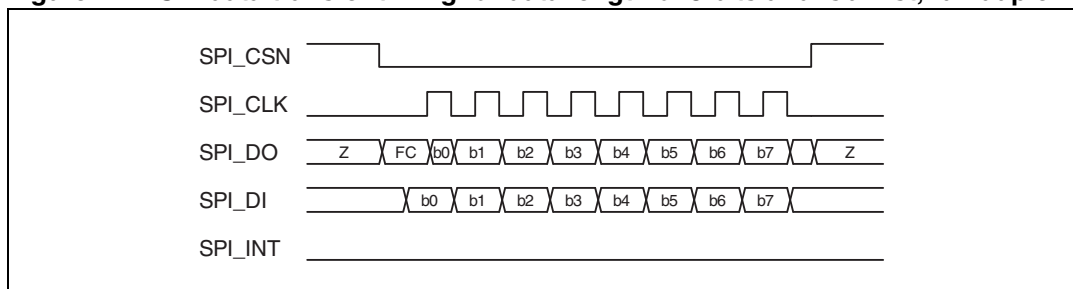

Figure 18. SPI setup and hold timing

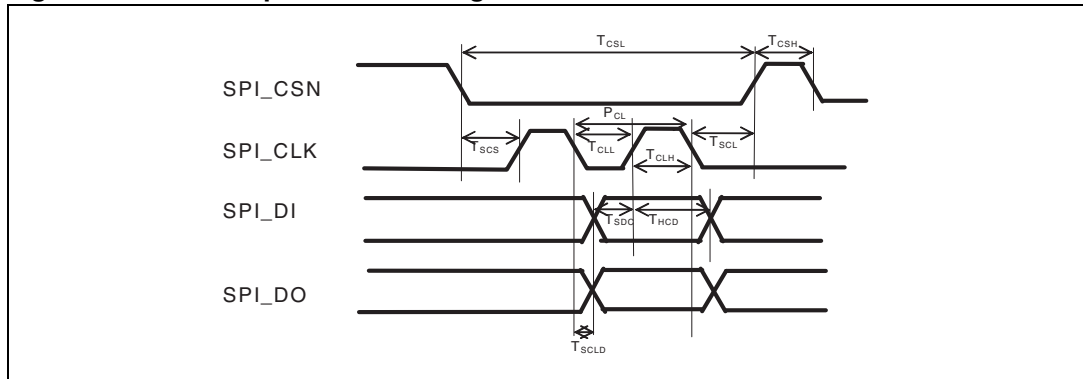

Table 25. SPI timing parameters

Symbol	Description	Min.	Typ.	Max.	Unit
P _{CL}	SPI_CLK full period	70	0	0	ns
T _{CLH}	High period of SPI_CLK	16.6			ns
T _{CLL}	Low period of SPI_CLK	26.4			ns
T _{CSH}	High period of SPI_CSN	1 * P _{CL}			ns
T _{CSL}	Low period of SPI_CSN	9 * P _{CL}			ns
T _{SCS}	Setup time, SPI_CSN Low to SPI_CLK high	1 * P _{CL}			ns
T _{SCL}	Setup time, SPI_CLK Low to SPI_CSN high	1/2 * P _{CL}			ns
T _{SDC}	Setup time, SPI_MOSI valid to SPI_CLK high	9.7	5		ns
T _{HCD}	Hold time, SPI_MOSI valid after SPI_CLK high	0			ns
T _{SCLD}	Setup time, SPI_CLK Low to SPI_MISO valid			26.5	ns

7.3 The PCM interface

The chip contains a 4-pin direct voice interface to connect to standard CODEC.

The interface supports multiport PCM operations for voice transfer. It can be programmed to act as a Master or a Slave via a SW parameter download or via specific HCI commands.

The four signals of the multiport PCM interface are:

- PCM_CLK : PCM clock
- PCM_SYNC : PCM 8 kHz sync (every 125 μs)
- PCM_A : PCM data (TX or RX)
- PCM_B : PCM data (RX or TX)

As a Master the interface by default generates a PCM clock rate of 2048 kHz, but it can be configured to rates from 8 kHz up to 2048 kHz. As a Slave, it can automatically handle external PCM clock rates from 128 kHz up to 4000 kHz. The default PCM_SYNC rate is 8 kHz.

The following external PCM data format are supported: linear (13 - 16 bit), μ-law (8 bit) or A-law (8 bit).

In Slave mode, all possible PCM_SYNC lengths are supported (including “short frame” (= 1 PCM_CLK period) and “long frame” (> 1 PCM_CLK period)). In Master mode, the length is configurable (1 (“short frame”), 8 or 16 (“long frame”) PCM_CLK periods).

The start of the PCM data is configurable. One possible configuration is e.g. for a short frame, the falling edge of the PCM_SYNC indicating the start of the PCM word. Another possible configuration is e.g. for a long frame, the rising edge of the PCM_SYNC indicating the start of the PCM word.

TX data are by default generated on the positive edge of PCM_CLK and expected to be latched by the external device on the negative edge while RX data are latched on the negative edge of PCM_CLK. But the inverted clock mode is also supported, whereby the generation of TX data is on the negative edge and the latching of TX and RX data is on the positive edge.

One additional PCM_SYNC signal can be provided via the GPIOs. See [section 7.5](#) for more details.

Figure 19. PCM (A-law, μ -law) standard mode

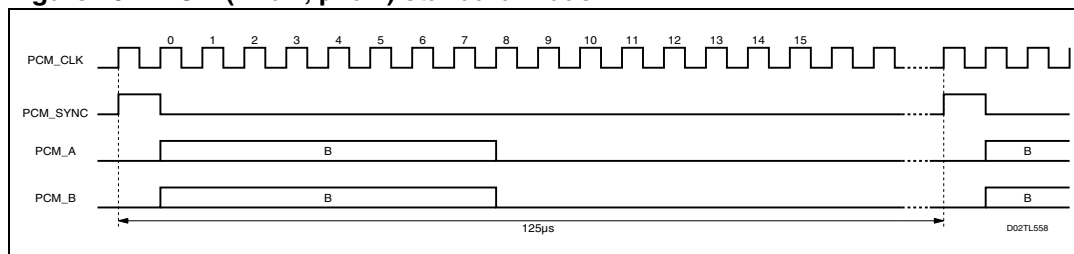

Figure 20. Linear mode

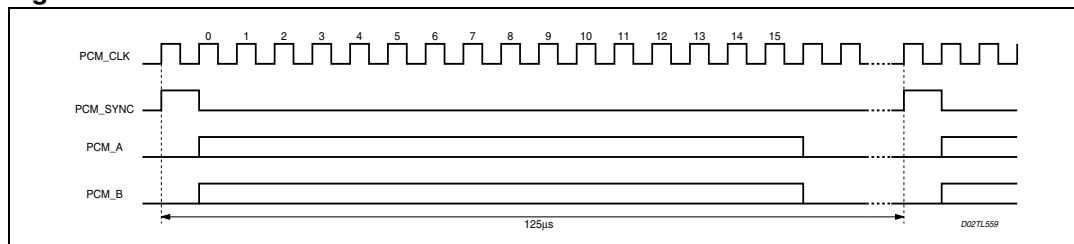
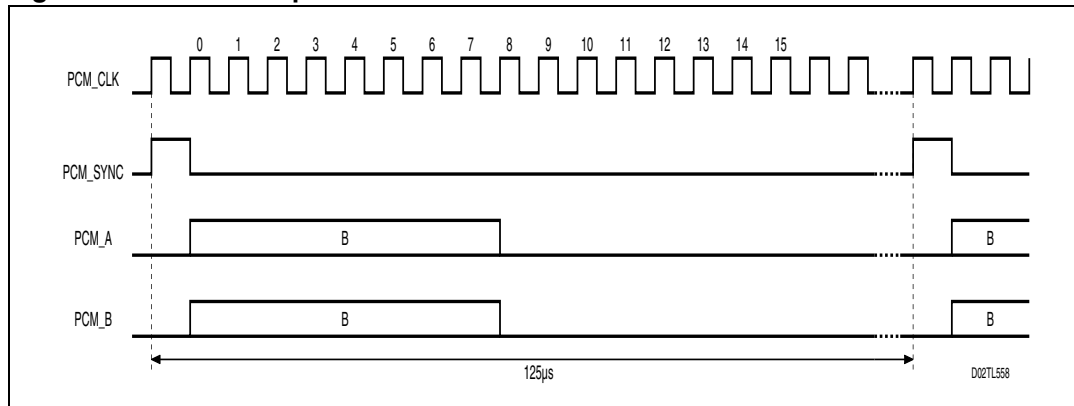

Figure 21. Multislot operation



The PCM implementation supports from 1 up to 3 slots per frame with the following parameters:

Table 26. PCM interface parameters

Symbol	Description	Min.	Typ.	Max.	Unit
PCM Interface					
F_{PCM_CLK}	Frequency of PCM_CLK (Slave)	128 ⁽¹⁾	2048	4000 ⁽²⁾	kHz
F_{PCM_SYNC}	Frequency of PCM_SYNC	-	8	-	kHz
P_{sync_delay}	Delay of the starting of the first slot	0	-	255	cycles
S_s	Slot start (programmable for every slot)	0	-	255	cycles
D	Data size	8	-	16	bits
N	Number of slots per frame	1	-	3	-

- Note that it is not possible to use 16 bits in Slave case if pcm_clk is 128kHz. This is the only exception.
- In Master case, the maximum of PCM_CLK is 2048 kHz.

Table 27. PCM interface timing (at PCM_CLK = 2048 kHz)

Symbol	Description	Min.	Typ.	Max.	Unit
t_{WCH}	High period of PCM_CLK	200	-	-	ns
t_{WCL}	Low period of PCM_CLK	200	-	-	ns
t_{WSH}	High period of PCM_SYNC	200	-	-	ns
t_{SSC}	Setup time, PCM_SYNC high to PCM_CLK low	100	-	-	ns
t_{SDC}	Setup time, PCM_A/B input valid to PCM_CLK low	100	-	-	ns
t_{HCD}	Hold time, PCM_CLK low to PCM_A/B input valid	100	-	-	ns
t_{DCD}	Delay time, PCM_CLK high to PCM_A/B output valid	-	-	150	ns

Figure 22. PCM interface timing

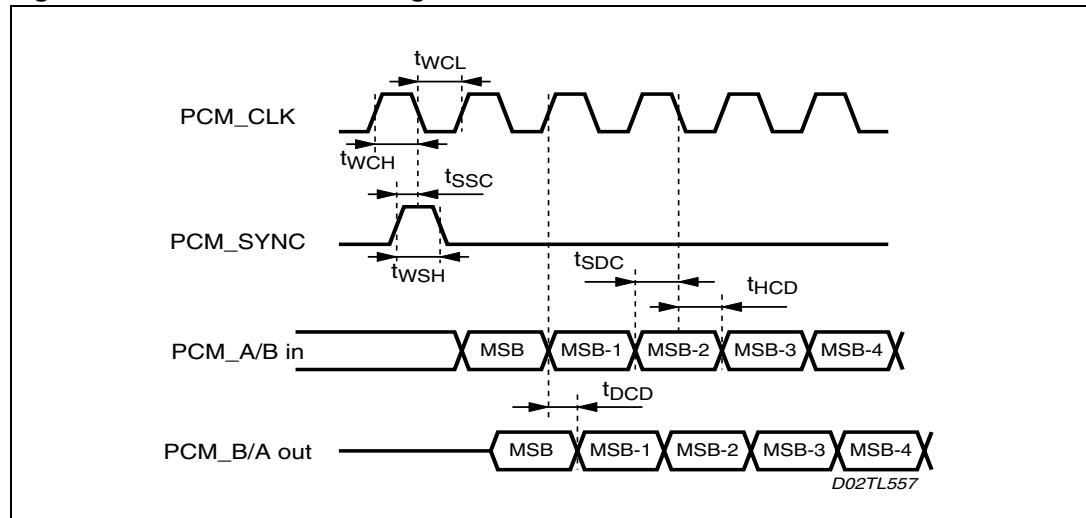

7.4 The JTAG interface

The JTAG interface is compliant with the JTAG IEEE Standard 1149.1. It allows both the boundary scan of the digital pins and the debug of the ARM7TDMI application when connected with the standard ARM7 developments tools. It is also used for the industrial test of the device. The JTAG interface is available through the following 5 pins: BT_GPIO_8, BT_GPIO_9, BT_GPIO_10, BT_GPIO_11 and BT_GPIO_16.

7.5 Alternate I/O functions

The STA2500D has 10 additional general purpose pins on top of the 4 PCM pins, the 4 UART pins and BT_CLK_REQ_OUT_1 that can also be reconfigured. They are fully programmable via specific HCI commands. They can be configured as input, output, interrupt with asynchronous or synchronous edge or level detection and/or wake-up.

The alternative functions are:

- Wake-up by the Host in Deep Sleep mode through UART or SPI with handshake (see [Section : Deep sleep mode entry and wake-up through H4 UART or H4 SPI with handshake](#))
- WLAN coexistence control
- I2C interface
- PCM synchronization
- GPIOs
- UART / SPI interface
- external driver/LNA control for Class 1 operation.

19 pins can be redefined by SW to perform other functions. Pin BT_HOST_WAKEUP e.g. can be redefined to perform up to 7 functions, depending on SW settings.

4 exemplary combinations of pin programmings are given in [Table 28](#). The available functions are

- ex. 1: UART + I2C + Class 1 control
- ex. 2: UART + WLAN + Class 1 control
- ex. 3: SPI + WLAN + Class 1 control
- ex. 4: SPI + WLAN + I²C + Class 1 control

(The complete list of alternate functions is available upon request).

Table 28. Examples of BT_GPIO pin programming

STA2500D Pin Name	ex. 1	ex. 2	ex. 3	ex. 4
BT_UART_RXD/BT_SPI_DI	UART_RXD	UART_RXD	SPI_DI	SPI_DI
BT_UART_TXD/BT_SPI_DO	UART_TXD	UART_TXD	SPI_DO	SPI_DO
BT_UART_CTS/BT_SPI_CLK	UART_CTS	UART_CTS	SPI_CLK	SPI_CLK
BT_UART_RTS/BT_SPI_CSN	UART_RTS	UART_RTS	SPI_CS	SPI_CS
BT_PCM_CLK	PCM_CLK	PCM_CLK	PCM_CLK	PCM_CLK
BT_PCM_SYNC	PCM_SYNC	PCM_SYNC	PCM_SYNC	PCM_SYNC
BT_PCM_A	PCM_A	PCM_A	PCM_A	PCM_A

Table 28. Examples of BT_GPIO pin programming (continued)

STA2500D Pin Name	ex. 1	ex. 2	ex. 3	ex. 4
BT_PCM_B	PCM_B	PCM_B	PCM_B	PCM_B
BT_GPIO_0	I2C_CLK	WLAN1	WLAN1	WLAN1
BT_CLK_REQ_IN_1	I2C_DAT	WLAN2	WLAN2	I2C_DAT
BT_CLK_REQ_IN_2	GPIO_2	WLAN3	WLAN3	WLAN3
BT_HOST_WAKEUP/BT_SPI_INT	HOST_WAKEUP	WLAN4	SPI_INT	SPI_INT
BT_GPIO_11	ANT_SWITCH	ANT_SWITCH	ANT_SWITCH	WLAN2
BT_GPIO_9	PA_LEVEL2	PA_LEVEL2	PA_LEVEL2	PA_LEVEL2
BT_GPIO_10	PA_LEVEL1	PA_LEVEL1	PA_LEVEL1	PA_LEVEL1
BT_GPIO_8	RX_ENABLE	RX_ENABLE	RX_ENABLE	RX_ENABLE
BT_GPIO_16	PA_ENABLE	PA_ENABLE	PA_ENABLE	PA_ENABLE
BT_CLK_REQ_OUT_1	CLK_REQ_OUT_1	CLK_REQ_OUT_1	CLK_REQ_OUT_1	CLK_REQ_OUT_1
BT_CLK_REQ_OUT_2	NA	NA	WLAN4	IC2_CLK

7.6 The I²C interface

The I²C interface is used to access I2C peripherals.

The interface is a fast Master I²C; it has full control of the interface at all times. I²C Slave functionality is not supported.

8 HCI transport layer

The STA2500D supports the HCI transport layer as defined by the SIG: H4 [1]. It is supported in combination with UART and SPI mode. The STA2500D also supports an enhanced version of the H4 protocol in combination with SPI mode.

8.1 H4 UART transport layer

The objective of HCI UART transport layer is to make it possible to use Bluetooth HCI over a serial interface between two UARTs on the same PCB. The HCI UART transport layer assumes that the UART communication is free from line errors.

UART settings

The HCI UART transport layer uses the following settings for RS232:

- Baud rate :configurable (default baud rate 115200 bps)
- Number of data bits :8
- Parity bit :no parity
- Stop bit :1 stop bit
- Flow control :RTS/CTS
- Flow-off response time :500 μ s

The flow-off response time defines the maximum time that the STA2500D can still receive data after setting RTS high.

RTS/CTS flow control is used to prevent temporary UART buffer overrun between the Bluetooth Controller and the Host.

The RS232 signals should be connected in a null-modem fashion, i.e. the Bluetooth Controller TXD output should be connected to the Host RXD input and the Bluetooth Controller RTS output should be connected to the Host CTS input and vice versa.

If the Bluetooth Controller RTS output (connected to the Host CTS input) is low, then the Host is allowed to send.

If the Bluetooth Controller RTS output (connected to the Host CTS input) is high, then the Host is not allowed to send.

If the Bluetooth Controller CTS input (connected to the Host RTS output) is low, then the Bluetooth Controller is allowed to send.

If the Bluetooth Controller CTS input (connected to the Host RTS output) is high, then the Bluetooth Controller is not allowed to send.

Figure 23. UART transport layer

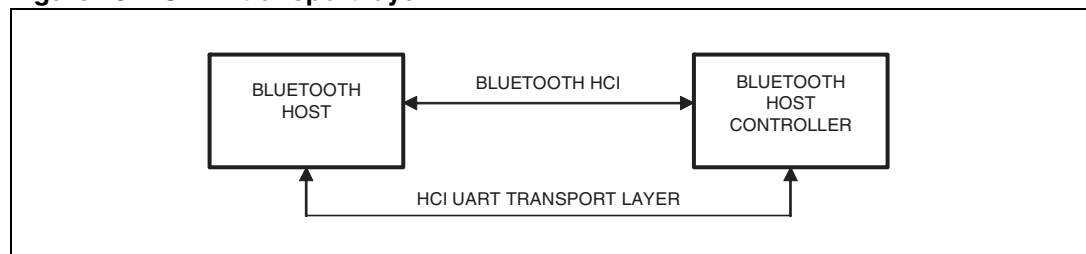

8.2 Enhanced H4 SPI transport layer

This is the default SPI mode.

The enhanced H4 protocol is based on the H4 protocol as defined by the SIG []. In addition a messaging protocol is defined for controlling the Deep Sleep mode entry and wake-up, see [Section : Deep sleep mode entry and wake-up through enhanced H4 SPI](#).

Three messages are defined: SLEEP, WAKEUP and WOKEN. More details on the messages are available upon request.

At SPI level, the default configuration is used:

- The SPI interface works in half duplex mode
- The data are exchanged in multiple of 16 bits
- The most significant byte first
- The most significant bit first
- There is a read and write command from the Host to access the Bluetooth device
- The Bluetooth device requests a transfer by the activation of the interrupt line
- Flow control on SPI_DO and in a register

8.3 H4 SPI transport layer

As stated in the previous section, the SPI interface is configurable. One possible configuration is the following, implementing a simple H4 SPI transport layer.

- The SPI interface works in half duplex mode
- The data are exchanged in multiples of 8 bits
- The least significant bit first
- There is a read and write command from the Host to access the Bluetooth device
- The Bluetooth device requests a transfer by the activation of the interrupt line
- Flow control on BT_SPI_DO and in a register

8.4 eSCO over HCI

The STA2500D supports synchronous data packet transfer (eSCO) over HCI.

9 Package information

In order to meet environmental requirements, ST offers these devices in different grades of ECOPACK® packages, depending on their level of environmental compliance. ECOPACK® specifications, grade definitions and product status are available at: www.st.com.

ECOPACK® is an ST trademark.

Figure 24. LFBGA48 (6x6x1.4mm) mechanical data and package dimensions

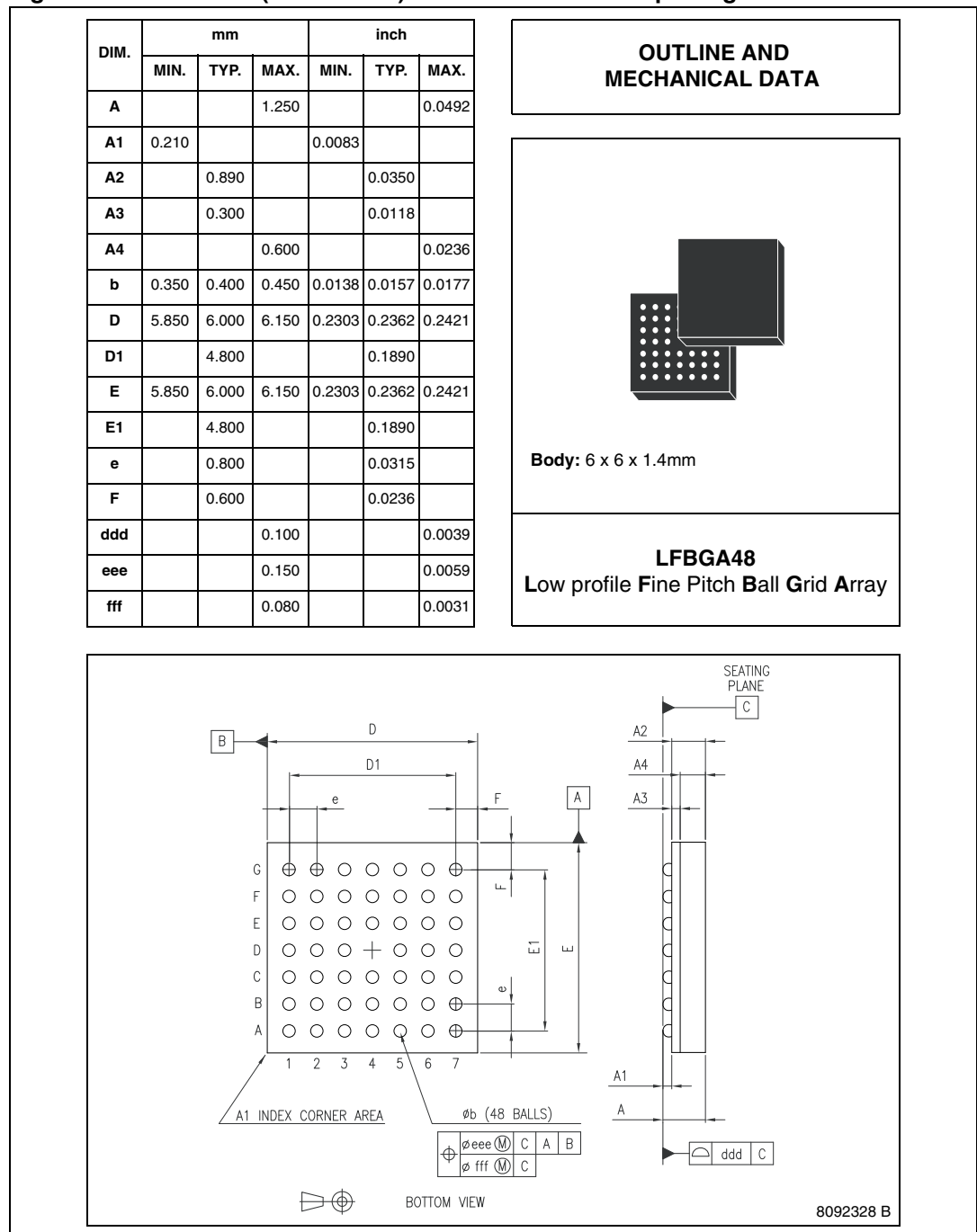

Figure 25. Package markings

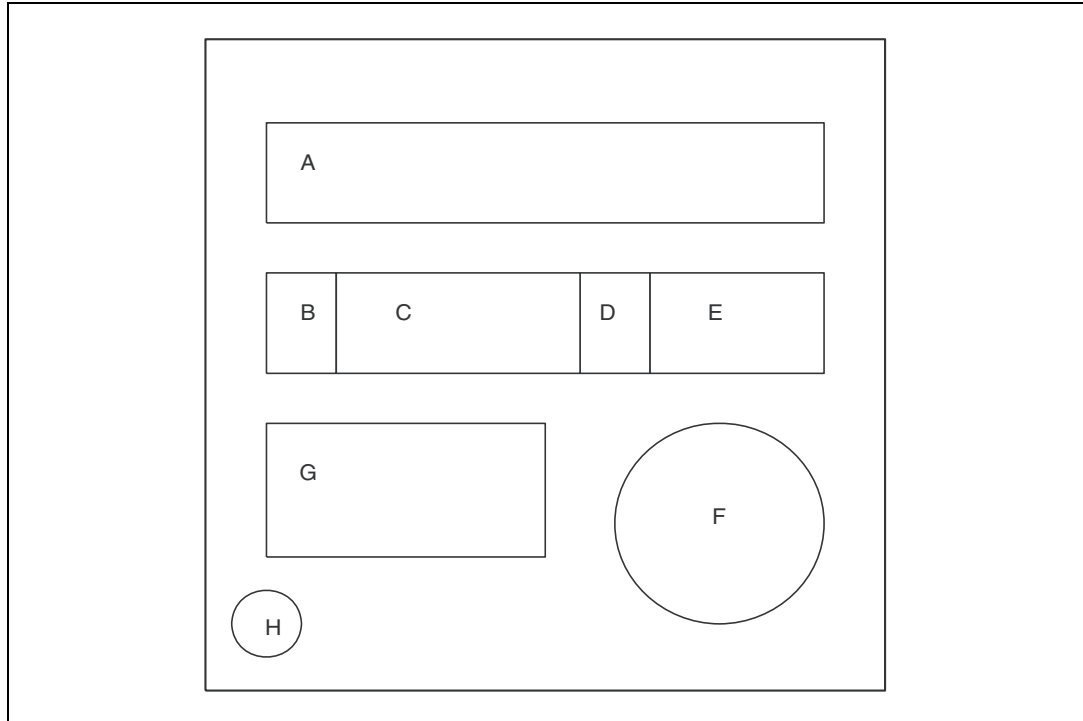

Table 29. Package markings legend

Item	Description	Format	Value
A	Type + version	XXXXXX	2500D7
B	Assembly Plant	P	-
C	BE sequence (LL)	LL	-
D	Assembly Year (Y)	Y	-
E	Assembly Week (WW)	WW	-
F	Second_lvl_intct	-	-
G	Standard ST Logo	-	-
H	Dot (pin A1)	-	-

Note: The ECO level is reflected in the “Order code” (see [Table 32](#))

10 References

Table 30. References

ID	Short name	Name	Date	Owner
[1]	-	Specification of the Bluetooth System V2.1 + EDR (“Lisbon”)	Not yet released	Bluetooth SIG
[2]	-	Specification of the Bluetooth System V2.0 + EDR	November 2004	Bluetooth SIG
[3]	-	Specification of the Bluetooth System V1.2	November 2003	Bluetooth SIG
[4]	-	Specification of the Bluetooth System - Host Controller Interface [Transport Layer] Volume 04 Revision 1.2 or later, 2006, part A: UART v1.1	January 2006	Bluetooth SIG
[5]	-	Radio Frequency Test Suite Structure (TSS) and Test Purposes (TP) System Specification 1.2/2.0/2.0 + EDR, document number RF.TS/2.0.E.3	March 2005	Bluetooth SIG
[6]	-	IEEE 802.15.2, IEEE Recommended Practice for Telecommunications and Information exchange between systems – Local and metropolitan area networks Specific Requirements - Part 15.2: Coexistence of Wireless Personal Area Networks with Other Wireless Devices Operating in Unlicensed Frequency Band	August 2003	IEEE
[7]	WLAN	IEEE 802.11, IEEE Standards for Information Technology -- Telecommunications and Information Exchange between Systems -- Local and Metropolitan Area Network -- Specific Requirements -- Part 11: Wireless LAN Medium Access Control (MAC) and Physical Layer (PHY) Specifications	1999	IEEE
[8]	802.11b	IEEE 802.11b, Supplement to 802.11-1999, Wireless LAN MAC and PHY specifications: Higher speed Physical Layer (PHY) extension in the 2.4 GHz band	1999	IEEE
[9]	802.11g	IEEE 802.11g, IEEE Standard for Information technology—Telecommunications and information exchange between systems—Local and metropolitan area networks—Specific requirements—Part 11: Wireless LAN Medium Access Control (MAC) and Physical Layer (PHY) specifications—Amendment 4: Further Higher-Speed Physical Layer Extension in the 2.4 GHz Band	2003	IEEE
[10]	-	STLC2500C_DS_Rev2.0.pdf, Datasheet of Bluetooth 2.0&EDR compliant single chip, Rev2.0 or later	-	-

11 Acronyms and abbreviations

Table 31. Acronyms and abbreviations

Acronyms/ abbreviation	Description
2-DH12- DH32-DH5	Bluetooth 2 Mbps ACL packet types
2-EV3 2-EV5	Bluetooth 2 Mbps synchronous packet types
3-DH1 3-DH3 3-DH5	Bluetooth 3 Mbps ACL packet types
3-EV3 3-EV5	Bluetooth 3 Mbps synchronous packet types
8-DPSK	8 phase Differential Phase Shift Keying
A/D	Analog to Digital
AC	Alternating Current
ACL	Asynchronous Connection Oriented
AHB	Advanced High-performance Bus
A-law	Audio encoding standard
AMBA	Advanced Micro-controller Bus Architecture
AMR	Absolute Maximum Rating
APB	Advanced Peripheral Bus
ARM7	Micro-processor
ARM7TDMI	Micro-processor
AWMA	Alternating Wireless Medium Access
BB	Base Band
BER	Bit Error Rate
BOM	Bill Of Materials
BR	Basic Rate
BT	Bluetooth
BW	Band Width
C/I	Carrier-to-co-channel Interference
CMOS	Complementary Metal Oxide Semiconductor
CODEC	COder DEcoder
CPU	Central Processing Unit
CQDDR	Channel Quality Driven Data Rate change
CVSD	Continuous Variable Slope Delta modulation
DC	Direct Current

Table 31. Acronyms and abbreviations (continued)

Acronyms/ abbreviation	Description
DEVM	Differential Error Vector Amplitude
DH1 DH3 DH5	Bluetooth 1 Mbps ACL packet types
DM1 DM3 DM5	Bluetooth 1 Mbps ACL packet types
DMA	Direct Memory Access
DV	Bluetooth 1 Mbps synchronous packet type
EBC	Ericsson technology licensing Baseband Core
EDR	Enhanced Data Rate
EIR	Extended Inquiry Response
EPR	Encryption Pause/Resume
eSCO	extended SCO
EV3 EV4 EV5	Bluetooth 1 Mbps synchronous packet types
FHS	Frequency Hopping Synchronization
GFSK	Gaussian Frequency Shift Keying
GPIO	General Purpose I/O pin
GSM	Global System for Mobile communications
H4	UART based HCI transport
HCI	Host Controller Interface
HV1 HV3	Bluetooth 1 Mbps synchronous packet types
HW	HardWare
I/O	Input/Output
I2C	Inter-Integrated Circuit
IF	Intermediate Frequency
ISM	Industrial, Scientific and Medical
JTAG	Joint Test Action Group
L2CAP	Logical Link Control and Adaptation Protocol
LMP	Link Manager Protocol
LNA	Low Noise Amplifier
LO	Local Oscillator
LSTO	Link Supervision Time Out
μ-law	Audio encoding standard

Table 31. Acronyms and abbreviations (continued)

Acronyms/ abbreviation	Description
$\pi/4$ -DQPSK	$\pi/4$ rotated Differential Quaternary Phase Shift Keying
PA	Power Amplifier
PCB	Printed Circuit Board
PCM	Pulse Code Modulation
PD	Pull-Down
PLL	Phase Locked Loop
PPEC	Pitch-Period Error Concealment
PTA	Packet Traffic Arbitration
PU	Pull-Up
QoS	Quality of Service
RAM	Random Access Memory
RC	Resistance-Capacitance
RF	Radio Frequency
rms	root mean squared
ROM	Read Only Memory
RS232	ANSI/EIA/TIA-232-F, September 1997, Interface Between Data Terminal Equipment and Data Circuit-Terminating Equipment Employing Serial Binary Data Interchange
RSSI	Receive Signal Strength Indication
RX	Receive
SCO	Synchronous Connection Oriented
SIG	Bluetooth Special Interest Group
SPI	Serial Peripheral Interface
ST	STMicroelectronics
SW	SoftWare
TBD	To Be Defined
T_{eSCO}	eSCO interval
T_{SCO}	SCO interval
T_{sniff}	Sniff interval
TX	Transmit
UART	Universal Asynchronous Receiver/Transmitter
VCO	Voltage Controlled Oscillator
VGA	Variable Gain Amplifier
WCDMA	Wideband Code Division Multiple Access
WFBGA	Very Very Thin Profile Fine Pitch Ball Grid Array
WLAN	Wireless Local Area Network
WLCSP	Wafer-Level Chip Scale Package

12 Order codes

Table 32. Ordering information

Order code	Package	Packing	Production
STA2500DC	LFBGA48	Tray	Simplified production flow
STA2500DCTR	LFBGA48	Tape and reel	Simplified production flow
STA2500D	LFBGA48	Tray	Automotive version
STA2500DTR	LFBGA48	Tape and reel	Automotive version

13 Revision history

Table 33. Document revision history

Date	Revision	Changes
24-Jul-2009	1	Initial release.
18-Jan-2010	2	Removed device summary table in cover page. Added Section 12: Order codes on page 56 .
17-Sep-2013	3	Updated Disclaimer

Please Read Carefully:

Information in this document is provided solely in connection with ST products. STMicroelectronics NV and its subsidiaries ("ST") reserve the right to make changes, corrections, modifications or improvements, to this document, and the products and services described herein at any time, without notice.

All ST products are sold pursuant to ST's terms and conditions of sale.

Purchasers are solely responsible for the choice, selection and use of the ST products and services described herein, and ST assumes no liability whatsoever relating to the choice, selection or use of the ST products and services described herein.

No license, express or implied, by estoppel or otherwise, to any intellectual property rights is granted under this document. If any part of this document refers to any third party products or services it shall not be deemed a license grant by ST for the use of such third party products or services, or any intellectual property contained therein or considered as a warranty covering the use in any manner whatsoever of such third party products or services or any intellectual property contained therein.

UNLESS OTHERWISE SET FORTH IN ST'S TERMS AND CONDITIONS OF SALE ST DISCLAIMS ANY EXPRESS OR IMPLIED WARRANTY WITH RESPECT TO THE USE AND/OR SALE OF ST PRODUCTS INCLUDING WITHOUT LIMITATION IMPLIED WARRANTIES OF MERCHANTABILITY, FITNESS FOR A PARTICULAR PURPOSE (AND THEIR EQUIVALENTS UNDER THE LAWS OF ANY JURISDICTION), OR INFRINGEMENT OF ANY PATENT, COPYRIGHT OR OTHER INTELLECTUAL PROPERTY RIGHT.

ST PRODUCTS ARE NOT DESIGNED OR AUTHORIZED FOR USE IN: (A) SAFETY CRITICAL APPLICATIONS SUCH AS LIFE SUPPORTING, ACTIVE IMPLANTED DEVICES OR SYSTEMS WITH PRODUCT FUNCTIONAL SAFETY REQUIREMENTS; (B) AERONAUTIC APPLICATIONS; (C) AUTOMOTIVE APPLICATIONS OR ENVIRONMENTS, AND/OR (D) AEROSPACE APPLICATIONS OR ENVIRONMENTS. WHERE ST PRODUCTS ARE NOT DESIGNED FOR SUCH USE, THE PURCHASER SHALL USE PRODUCTS AT PURCHASER'S SOLE RISK, EVEN IF ST HAS BEEN INFORMED IN WRITING OF SUCH USAGE, UNLESS A PRODUCT IS EXPRESSLY DESIGNATED BY ST AS BEING INTENDED FOR "AUTOMOTIVE, AUTOMOTIVE SAFETY OR MEDICAL" INDUSTRY DOMAINS ACCORDING TO ST PRODUCT DESIGN SPECIFICATIONS. PRODUCTS FORMALLY ESCC, QML OR JAN QUALIFIED ARE DEEMED SUITABLE FOR USE IN AEROSPACE BY THE CORRESPONDING GOVERNMENTAL AGENCY.

Resale of ST products with provisions different from the statements and/or technical features set forth in this document shall immediately void any warranty granted by ST for the ST product or service described herein and shall not create or extend in any manner whatsoever, any liability of ST.

ST and the ST logo are trademarks or registered trademarks of ST in various countries.

Information in this document supersedes and replaces all information previously supplied.

The ST logo is a registered trademark of STMicroelectronics. All other names are the property of their respective owners.

© 2013 STMicroelectronics - All rights reserved

STMicroelectronics group of companies

Australia - Belgium - Brazil - Canada - China - Czech Republic - Finland - France - Germany - Hong Kong - India - Israel - Italy - Japan - Malaysia - Malta - Morocco - Philippines - Singapore - Spain - Sweden - Switzerland - United Kingdom - United States of America

www.st.com

Looking for pricing, stock, or lifecycle information?

Click below to explore more details on WIN SOURCE:

- ⊖ [View STA2500DTR on WIN SOURCE](#)
- ⊖ [STMicroelectronics Information](#)

Optimize Your Supply Chain with WIN SOURCE Solutions

- ✓ Global Sourcing Solution
- ✓ Obsolete Management
- ✓ Cost Control Management
- ✓ Shortage Management
- ✓ Alternative Solution
- ✓ Excess Inventory Management