

# 74LV574

Octal D-type flip-flop; positive edge-trigger; 3-state

Rev. 04 — 14 May 2009

Product data sheet

## 1. General description

The 74LV574 is an octal D-type flip-flop featuring separate D-type inputs for each flip-flop and non-inverting 3-state outputs for bus oriented applications. A clock (CP) and an output enable ( $\overline{OE}$ ) input are common to all flip-flops. It is a low-voltage Si-gate CMOS device and is pin and functionally compatible with the 74HC574 and 74HCT574.

The eight flip-flops will store the state of their individual D-inputs that meet the set-up and hold times requirements on the LOW to HIGH CP transition.

When  $\overline{OE}$  is LOW, the contents of the eight flip-flops is available at the outputs. When  $\overline{OE}$  is HIGH, the outputs go to the high-impedance OFF-state. Operation of the  $\overline{OE}$  input does not affect the state of the flip-flops.

## 2. Features

- Wide operating voltage: 1.0 V to 5.5 V
- Optimized for low voltage applications: 1.0 V to 3.6 V
- Accepts TTL input levels between  $V_{CC} = 2.7$  V and  $V_{CC} = 3.6$  V
- Typical output ground bounce < 0.8 V at  $V_{CC} = 3.3$  V and  $T_{amb} = 25$  °C
- Typical HIGH-level output voltage ( $V_{OH}$ ) undershoot: > 2 V at  $V_{CC} = 3.3$  V and  $T_{amb} = 25$  °C
- ESD protection:
  - ◆ HBM JESD22-A114E exceeds 2000 V
  - ◆ MM JESD22-A115-A exceeds 200 V
- Common 3-state output enable input
- Multiple package options
- Specified from  $-40$  °C to  $+85$  °C and from  $-40$  °C to  $+125$  °C

## 3. Ordering information

Table 1. Ordering information

Type number	Package			Version
	Temperature range	Name	Description	
74LV574N	$-40$ °C to $+125$ °C	DIP20	plastic dual in-line package; 20 leads (300 mil)	SOT146-1
74LV574D	$-40$ °C to $+125$ °C	SO20	plastic small outline package; 20 leads; body width 7.5 mm	SOT163-1
74LV574DB	$-40$ °C to $+125$ °C	SSOP20	plastic shrink small outline package; 20 leads; body width 5.3 mm	SOT339-1
74LV574PW	$-40$ °C to $+125$ °C	TSSOP20	plastic thin shrink small outline package; 20 leads; body width 4.4 mm	SOT360-1

### 4. Functional diagram

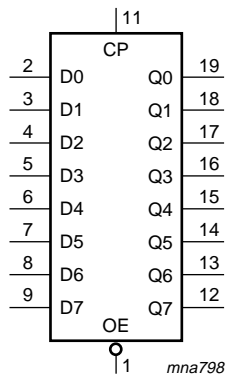

Fig 1. Logic symbol

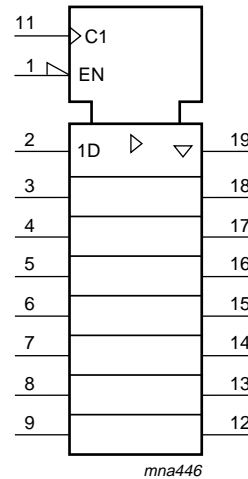

Fig 2. IEC logic symbol

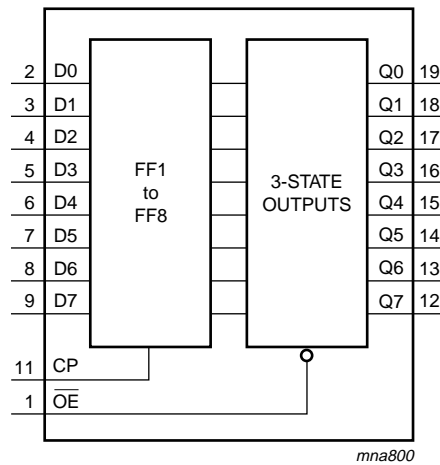

Fig 3. Functional diagram

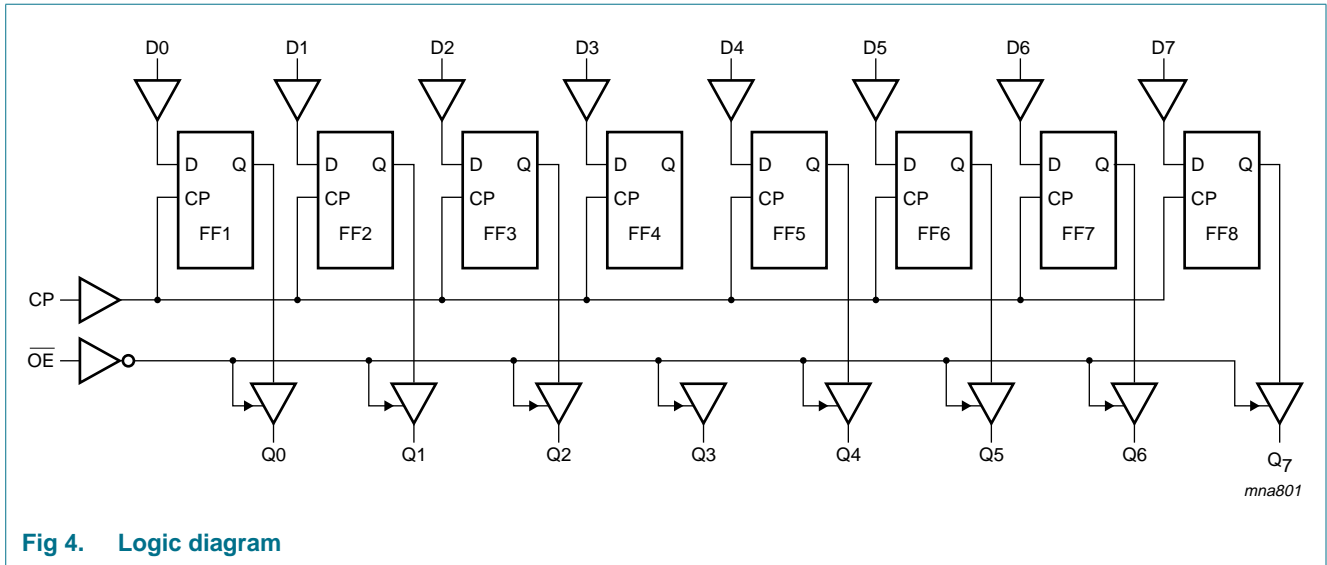

Fig 4. Logic diagram

## 5. Pinning information

### 5.1 Pinning

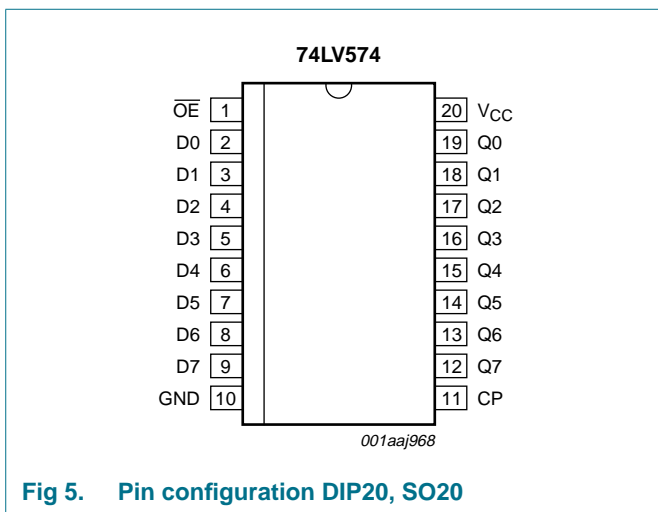

Fig 5. Pin configuration DIP20, SO20

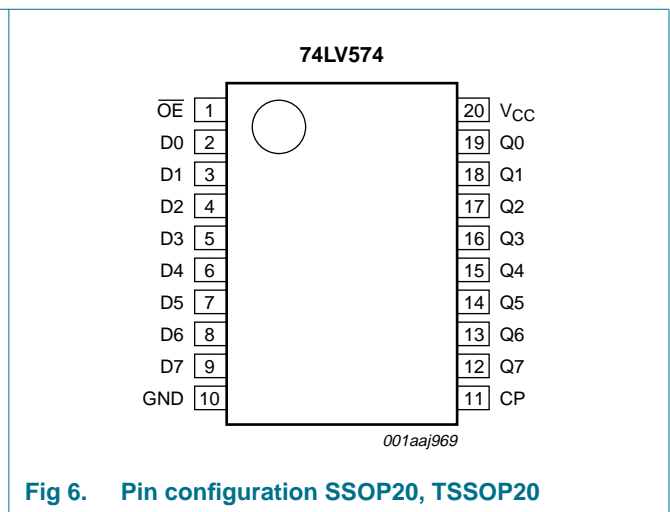

Fig 6. Pin configuration SSOP20, TSSOP20

### 5.2 Pin description

Table 2. Pin description

Symbol	Pin	Description
OE	1	output enable input (active LOW)
D0 to D7	2, 3, 4, 5, 6, 7, 8, 9	data input
GND	10	ground (0 V)
CP	11	clock input (LOW to HIGH; edge triggered)
Q0 to Q7	19, 18, 17, 16, 15, 14, 13, 12	data output
V <sub>CC</sub>	20	supply voltage

## 6. Functional description

Table 3. Function table<sup>[1]</sup>

Operating mode	Input			Internal flip-flop	Output Qn
	OE	CP	Dn		
Load and read register	L	↑	l	L	L
	L	↑	h	H	H
Load register and disable outputs	H	↑	l	L	Z
	H	↑	h	H	Z

- [1] H = HIGH voltage level  
 h = HIGH voltage level one set-up time prior to the LOW to HIGH CP transition  
 L = LOW voltage level  
 l = LOW voltage level one set-up time prior to the LOW to HIGH CP transition  
 Z = high-impedance OFF-state  
 ↑ = LOW to HIGH clock transition

## 7. Limiting values

Table 4. Limiting values

In accordance with the Absolute Maximum Rating System (IEC 60134). Voltages are referenced to GND (ground = 0 V).

Symbol	Parameter	Conditions	Min	Max	Unit
V <sub>CC</sub>	supply voltage		-0.5	+7.0	V
I <sub>IK</sub>	input clamping current	V <sub>I</sub> < -0.5 V or V <sub>I</sub> > V <sub>CC</sub> + 0.5 V	[1] -	±20	mA
I <sub>OK</sub>	output clamping current	V <sub>O</sub> < -0.5 V or V <sub>O</sub> > V <sub>CC</sub> + 0.5 V	[1] -	±50	mA
I <sub>O</sub>	output current	V <sub>O</sub> = -0.5 V to (V <sub>CC</sub> + 0.5 V)	-	±35	mA
I <sub>CC</sub>	supply current		-	70	mA
I <sub>GND</sub>	ground current		-70	-	mA
T <sub>stg</sub>	storage temperature		-65	+150	°C
P <sub>tot</sub>	total power dissipation	T <sub>amb</sub> = -40 °C to +125 °C	[2]		
		DIP20	-	750	mW
		SO20, SSOP20 and TSSOP20	-	500	mW

- [1] The input and output voltage ratings may be exceeded if the input and output current ratings are observed.  
 [2] For DIP20 packages: above 70 °C the value of P<sub>tot</sub> derates linearly with 12 mW/K.  
 For SO20 packages: above 70 °C the value of P<sub>tot</sub> derates linearly with 8 mW/K.  
 For (T)SSOP20 packages: above 60 °C the value of P<sub>tot</sub> derates linearly with 5.5 mW/K.

## 8. Recommended operating conditions

**Table 5. Recommended operating conditions**

Voltages are referenced to GND (ground = 0 V).

Symbol	Parameter	Conditions	Min	Typ	Max	Unit
$V_{CC}$	supply voltage <sup>[1]</sup>		1.0	3.3	5.5	V
$V_I$	input voltage		0	-	$V_{CC}$	V
$V_O$	output voltage		0	-	$V_{CC}$	V
$T_{amb}$	ambient temperature		-40	+25	+125	°C
$\Delta t/\Delta V$	input transition rise and fall rate	$V_{CC} = 1.0\text{ V to }2.0\text{ V}$	-	-	500	ns/V
		$V_{CC} = 2.0\text{ V to }2.7\text{ V}$	-	-	200	ns/V
		$V_{CC} = 2.7\text{ V to }3.6\text{ V}$	-	-	100	ns/V
		$V_{CC} = 3.6\text{ V to }5.5\text{ V}$	-	-	50	ns/V

[1] The static characteristics are guaranteed from  $V_{CC} = 1.2\text{ V}$  to  $V_{CC} = 5.5\text{ V}$ , but LV devices are guaranteed to function down to  $V_{CC} = 1.0\text{ V}$  (with input levels GND or  $V_{CC}$ ).

## 9. Static characteristics

**Table 6. Static characteristics**

At recommended operating conditions. Voltages are referenced to GND (ground = 0 V).

Symbol	Parameter	Conditions	-40 °C to +85 °C			-40 °C to +125 °C		Unit
			Min	Typ <sup>[1]</sup>	Max	Min	Max	
$V_{IH}$	HIGH-level input voltage	$V_{CC} = 1.2\text{ V}$	0.9	-	-	0.9	-	V
		$V_{CC} = 2.0\text{ V}$	1.4	-	-	1.4	-	V
		$V_{CC} = 2.7\text{ V to }3.6\text{ V}$	2.0	-	-	2.0	-	V
		$V_{CC} = 4.5\text{ V to }5.5\text{ V}$	$0.7V_{CC}$	-	-	$0.7V_{CC}$	-	V
$V_{IL}$	LOW-level input voltage	$V_{CC} = 1.2\text{ V}$	-	-	0.3	-	0.3	V
		$V_{CC} = 2.0\text{ V}$	-	-	0.6	-	0.6	V
		$V_{CC} = 2.7\text{ V to }3.6\text{ V}$	-	-	0.8	-	0.8	V
		$V_{CC} = 4.5\text{ V to }5.5\text{ V}$	-	-	$0.3V_{CC}$	-	$0.3V_{CC}$	V
$V_{OH}$	HIGH-level output voltage	$V_I = V_{IH}$ or $V_{IL}$						
		$I_O = -100\ \mu\text{A}; V_{CC} = 1.2\text{ V}$	-	1.2	-	-	-	V
		$I_O = -100\ \mu\text{A}; V_{CC} = 2.0\text{ V}$	1.8	2.0	-	1.8	-	V
		$I_O = -100\ \mu\text{A}; V_{CC} = 2.7\text{ V}$	2.5	2.7	-	2.5	-	V
		$I_O = -100\ \mu\text{A}; V_{CC} = 3.0\text{ V}$	2.8	3.0	-	2.8	-	V
		$I_O = -100\ \mu\text{A}; V_{CC} = 4.5\text{ V}$	4.3	4.5	-	4.3	-	V
		$I_O = -8\text{ mA}; V_{CC} = 3.0\text{ V}$	2.4	2.82	-	2.2	-	V
$I_O = -16\text{ mA}; V_{CC} = 4.5\text{ V}$	3.6	4.2	-	3.5	-	V		

**Table 6. Static characteristics ...continued**

At recommended operating conditions. Voltages are referenced to GND (ground = 0 V).

Symbol	Parameter	Conditions	-40 °C to +85 °C			-40 °C to +125 °C		Unit
			Min	Typ <sup>[1]</sup>	Max	Min	Max	
V <sub>OL</sub>	LOW-level output voltage	V <sub>I</sub> = V <sub>IH</sub> or V <sub>IL</sub>						
		I <sub>O</sub> = 100 μA; V <sub>CC</sub> = 1.2 V	-	0	-	-	-	V
		I <sub>O</sub> = 100 μA; V <sub>CC</sub> = 2.0 V	-	0	0.2	-	0.2	V
		I <sub>O</sub> = 100 μA; V <sub>CC</sub> = 2.7 V	-	0	0.2	-	0.2	V
		I <sub>O</sub> = 100 μA; V <sub>CC</sub> = 3.0 V	-	0	0.2	-	0.2	V
		I <sub>O</sub> = 100 μA; V <sub>CC</sub> = 4.5 V	-	0	0.2	-	0.2	V
		I <sub>O</sub> = 8 mA; V <sub>CC</sub> = 3.0 V	-	0.25	0.40	-	0.50	V
		I <sub>O</sub> = 16 mA; V <sub>CC</sub> = 4.5 V	-	0.35	0.55	-	0.65	V
I <sub>I</sub>	input leakage current	V <sub>I</sub> = V <sub>CC</sub> or GND; V <sub>CC</sub> = 5.5 V	-	-	1.0	-	1.0	μA
I <sub>OZ</sub>	OFF-state output current	V <sub>I</sub> = V <sub>IH</sub> or V <sub>IL</sub> ; V <sub>O</sub> = V <sub>CC</sub> or GND; V <sub>CC</sub> = 5.5 V	-	-	5	-	10	μA
I <sub>CC</sub>	supply current	V <sub>I</sub> = V <sub>CC</sub> or GND; I <sub>O</sub> = 0 A; V <sub>CC</sub> = 5.5 V	-	-	20	-	160	μA
ΔI <sub>CC</sub>	additional supply current	per input; V <sub>I</sub> = V <sub>CC</sub> - 0.6 V; V <sub>CC</sub> = 2.7 V to 3.6 V	-	-	500	-	850	μA
C <sub>I</sub>	input capacitance		-	3.5	-	-	-	pF

[1] Typical values are measured at T<sub>amb</sub> = 25 °C.

## 10. Dynamic characteristics

**Table 7. Dynamic characteristics**

Voltages are referenced to GND (ground = 0 V). For test circuit see [Figure 10](#).

Symbol	Parameter	Conditions	-40 °C to +85 °C			-40 °C to +125 °C		Unit
			Min	Typ <sup>[1]</sup>	Max	Min	Max	
t <sub>pd</sub>	propagation delay	CP to Qn; see <a href="#">Figure 7</a> <sup>[2]</sup>						
		V <sub>CC</sub> = 1.2 V	-	80	-	-	-	ns
		V <sub>CC</sub> = 2.0 V	-	27	34	-	43	ns
		V <sub>CC</sub> = 2.7 V	-	20	25	-	31	ns
		V <sub>CC</sub> = 3.0 V to 3.6 V; C <sub>L</sub> = 15 pF <sup>[3]</sup>	-	13	-	-	-	ns
		V <sub>CC</sub> = 3.0 V to 3.6 V <sup>[3]</sup>	-	15	20	-	25	ns
		V <sub>CC</sub> = 4.5 V to 5.5 V	-	-	17	-	21	ns
t <sub>en</sub>	enable time	OE to Qn; see <a href="#">Figure 8</a> <sup>[4]</sup>						
		V <sub>CC</sub> = 1.2 V	-	70	-	-	-	ns
		V <sub>CC</sub> = 2.0 V	-	24	34	-	43	ns
		V <sub>CC</sub> = 2.7 V	-	18	25	-	31	ns
		V <sub>CC</sub> = 3.0 V to 3.6 V <sup>[3]</sup>	-	13	20	-	25	ns
		V <sub>CC</sub> = 4.5 V to 5.5 V	-	-	17	-	21	ns

**Table 7. Dynamic characteristics ...continued**

Voltages are referenced to GND (ground = 0 V). For test circuit see [Figure 10](#).

Symbol	Parameter	Conditions	-40 °C to +85 °C			-40 °C to +125 °C		Unit
			Min	Typ <sup>[1]</sup>	Max	Min	Max	
t <sub>dis</sub>	disable time	OE to Qn; <a href="#">Figure 8</a> <sup>[5]</sup>						
		V <sub>CC</sub> = 1.2 V	-	75	-	-	-	ns
		V <sub>CC</sub> = 2.0 V	-	27	27	-	34	ns
		V <sub>CC</sub> = 2.7 V	-	21	21	-	26	ns
		V <sub>CC</sub> = 3.0 V to 3.6 V <sup>[3]</sup>	-	16	17	-	21	ns
t <sub>w</sub>	pulse width	CP, HIGH or LOW; see <a href="#">Figure 7</a>						
		V <sub>CC</sub> = 2.0 V	34	9	-	41	-	ns
		V <sub>CC</sub> = 2.7 V	25	6	-	30	-	ns
		V <sub>CC</sub> = 3.0 V to 3.6 V <sup>[3]</sup>	20	5	-	24	-	ns
t <sub>su</sub>	set-up time	Dn to CP; see <a href="#">Figure 9</a>						
		V <sub>CC</sub> = 1.2 V	-	10	-	-	-	ns
		V <sub>CC</sub> = 2.0 V	22	4	-	26	-	ns
		V <sub>CC</sub> = 2.7 V	16	3	-	19	-	ns
t <sub>h</sub>	hold time	Dn to CP; see <a href="#">Figure 9</a>						
		V <sub>CC</sub> = 1.2 V	-	-10	-	-	-	ns
		V <sub>CC</sub> = 2.0 V	5	-4	-	5	-	ns
		V <sub>CC</sub> = 2.7 V	5	-3	-	5	-	ns
f <sub>max</sub>	maximum frequency	see <a href="#">Figure 7</a>						
		V <sub>CC</sub> = 2.0 V	15	40	-	12	-	MHz
		V <sub>CC</sub> = 2.7 V	19	58	-	16	-	MHz
C <sub>PD</sub>	power dissipation capacitance	C <sub>L</sub> = 50 pF; f <sub>i</sub> = 1 MHz; V <sub>I</sub> = GND to V <sub>CC</sub> <sup>[6]</sup>		25				pF

- [1] Typical values are measured at T<sub>amb</sub> = 25 °C.
- [2] t<sub>pd</sub> is the same as t<sub>PLH</sub> and t<sub>PHL</sub>.
- [3] Typical value measured at V<sub>CC</sub> = 3.3 V.
- [4] t<sub>en</sub> is the same as t<sub>PZH</sub> and t<sub>PZL</sub>.
- [5] t<sub>dis</sub> is the same as t<sub>PHZ</sub> and t<sub>PLZ</sub>.
- [6] C<sub>PD</sub> is used to determine the dynamic power dissipation (P<sub>D</sub> in μW).  
 $P_D = C_{PD} \times V_{CC}^2 \times f_i \times N + \sum(C_L \times V_{CC}^2 \times f_o)$  where:  
 f<sub>i</sub> = input frequency in MHz;  
 f<sub>o</sub> = output frequency in MHz;  
 C<sub>L</sub> = output load capacitance in pF;  
 V<sub>CC</sub> = supply voltage in V;  
 N = number of inputs switching;  
 $\sum(C_L \times V_{CC}^2 \times f_o)$  = sum of outputs.

11. Waveforms

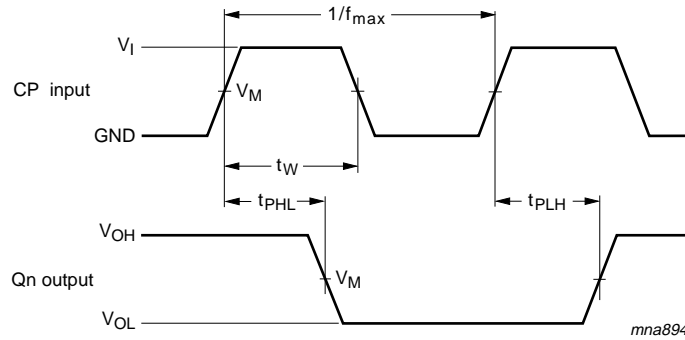

Measurement points are given in [Table 8](#).  
 $V_{OL}$  and  $V_{OH}$  are typical output voltage levels that occur with the output load.

**Fig 7. The clock (CP) to output (Qn) propagation delays, the clock pulse (CP) and the maximum clock pulse frequency**

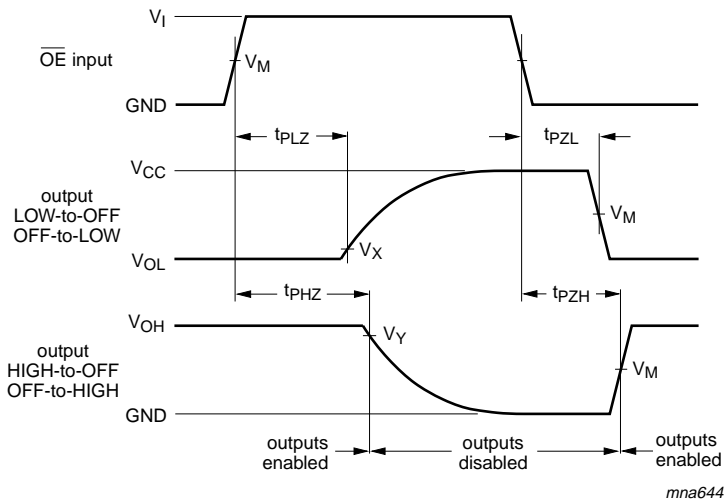

Measurement points are given in [Table 8](#).  
 $V_{OL}$  and  $V_{OH}$  are typical output voltage levels that occur with the output load.

**Fig 8. Enable and disable times**

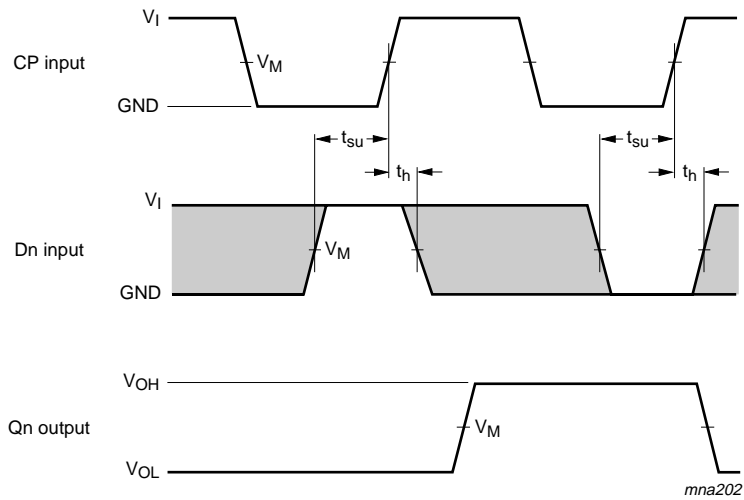

Measurement points are given in [Table 8](#).

The shaded areas indicate when the input is permitted to change for predictable output performance.

$V_{OL}$  and  $V_{OH}$  are typical output voltage levels that occur with the output load.

**Fig 9. The data set-up and hold times for the Dn input to the CP input)**

**Table 8. Measurement points**

Supply voltage $V_{CC}$	Input	Output		
	$V_M$	$V_M$	$V_x$	$V_y$
< 2.7 V	$0.5V_{CC}$	$0.5V_{CC}$	$V_{OL} + 0.3 V$	$V_{OH} - 0.3 V$
2.7 V to 3.6 V	1.5 V	1.5 V	$V_{OL} + 0.3 V$	$V_{OH} - 0.3 V$
$\geq 4.5 V$	$0.5V_{CC}$	$0.5V_{CC}$	$V_{OL} + 0.3 V$	$V_{OH} - 0.3 V$

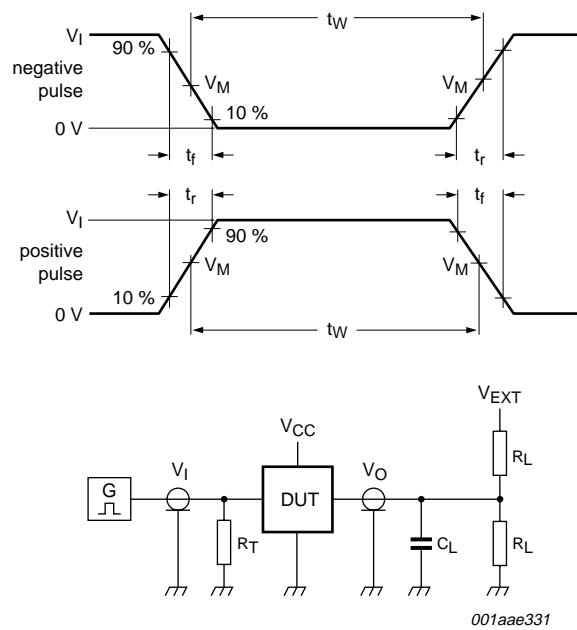

Test data is given in [Table 9](#).

Definitions for test circuit:

$R_L$  = Load resistance.

$C_L$  = Load capacitance including jig and probe capacitance.

$R_T$  = Termination resistance should be equal to output impedance  $Z_o$  of the pulse generator.

$V_{EXT}$  = External voltage for measuring switching times.

**Fig 10. Test circuit for measuring switching times**

**Table 9. Test data**

Supply voltage	Input		Load		$V_{EXT}$		
$V_{CC}$	$V_I$	$t_r, t_f$	$C_L$	$R_L$	$t_{PHL}, t_{PLH}$	$t_{PZH}, t_{PHZ}$	$t_{PZL}, t_{PLZ}$
< 2.7 V	$V_{CC}$	$\leq 2.5$ ns	50 pF	1 k $\Omega$	open	GND	$2V_{CC}$
2.7 V to 3.6 V	2.7 V	$\leq 2.5$ ns	15 pF, 50 pF	1 k $\Omega$	open	GND	$2V_{CC}$
$\geq 4.5$ V	$V_{CC}$	$\leq 2.5$ ns	50 pF	1 k $\Omega$	open	GND	$2V_{CC}$

12. Package outline

DIP20: plastic dual in-line package; 20 leads (300 mil)

SOT146-1

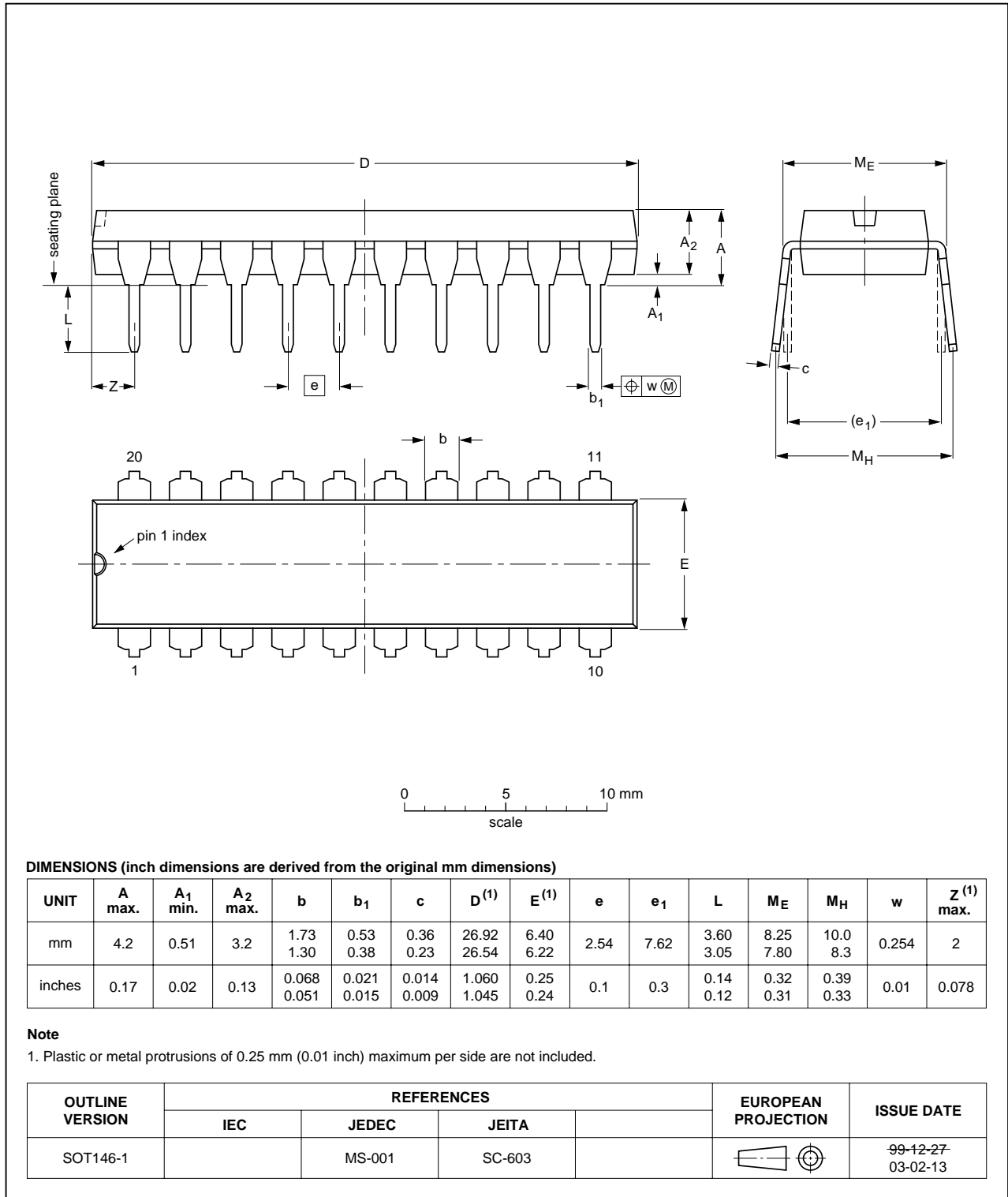

Fig 11. Package outline SOT146-1 (DIP20)

SO20: plastic small outline package; 20 leads; body width 7.5 mm

SOT163-1

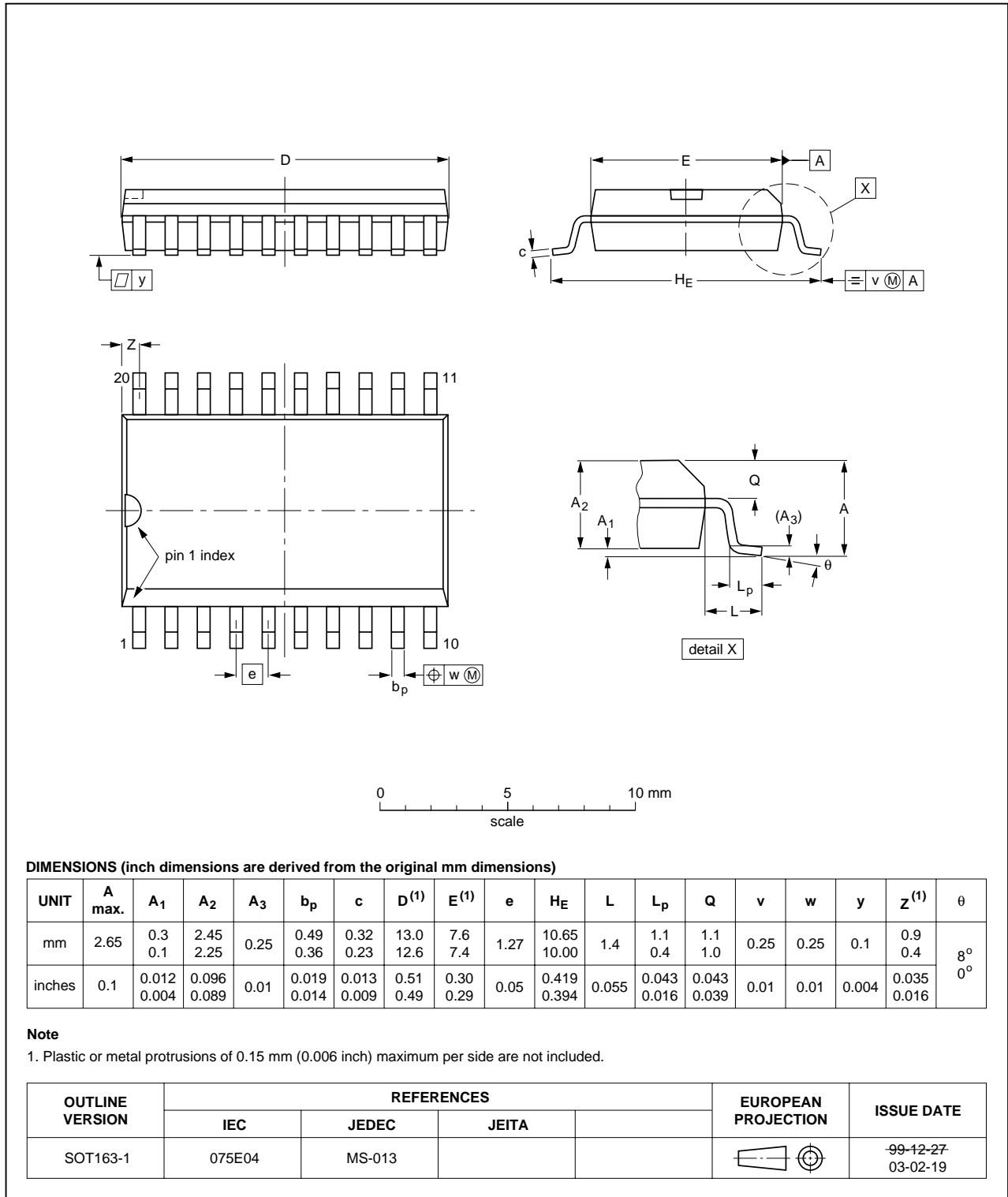

Fig 12. Package outline SOT163-1 (SO20)

SSOP20: plastic shrink small outline package; 20 leads; body width 5.3 mm

SOT339-1

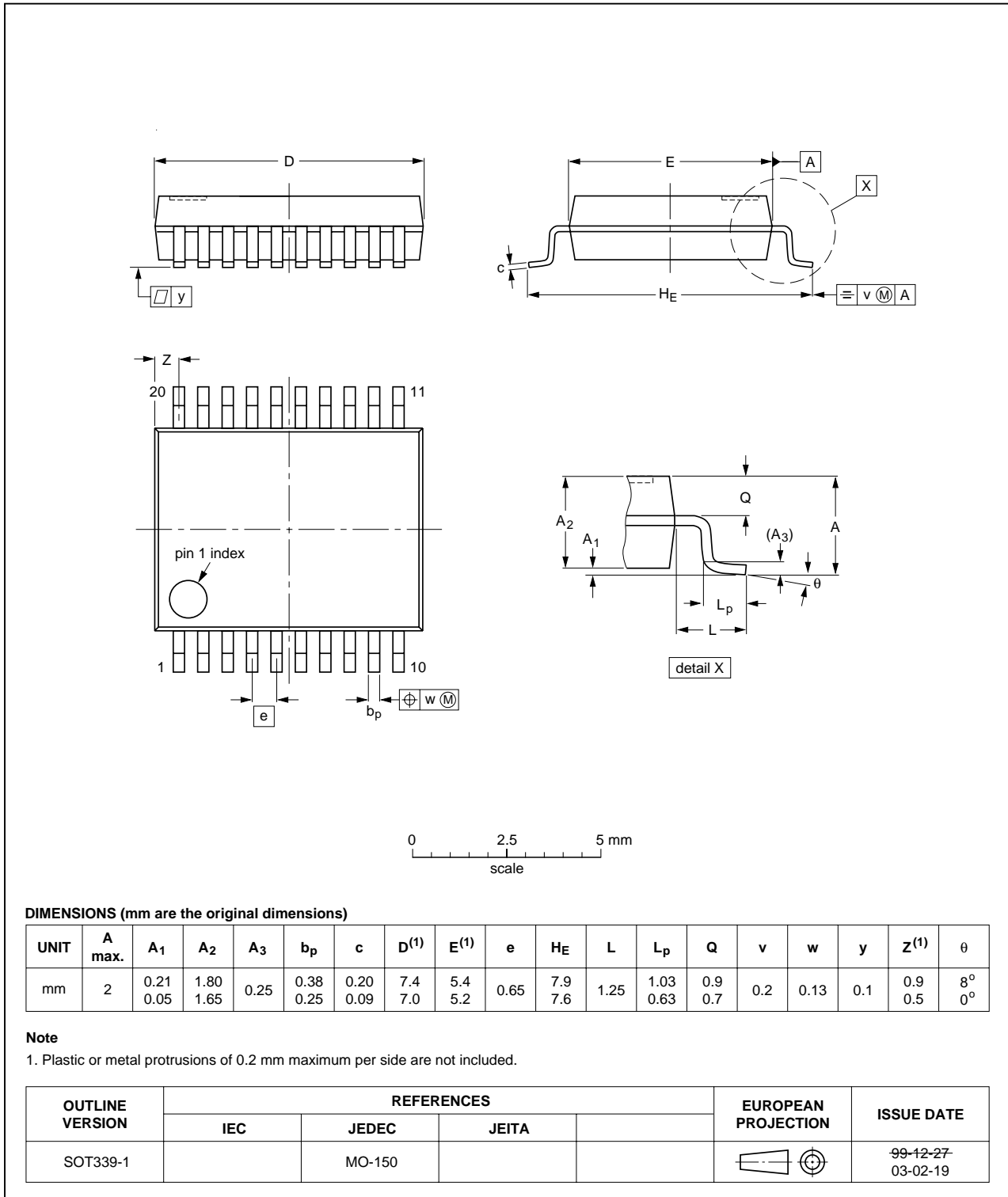

Fig 13. Package outline SOT339-1 (SSOP20)

TSSOP20: plastic thin shrink small outline package; 20 leads; body width 4.4 mm

SOT360-1

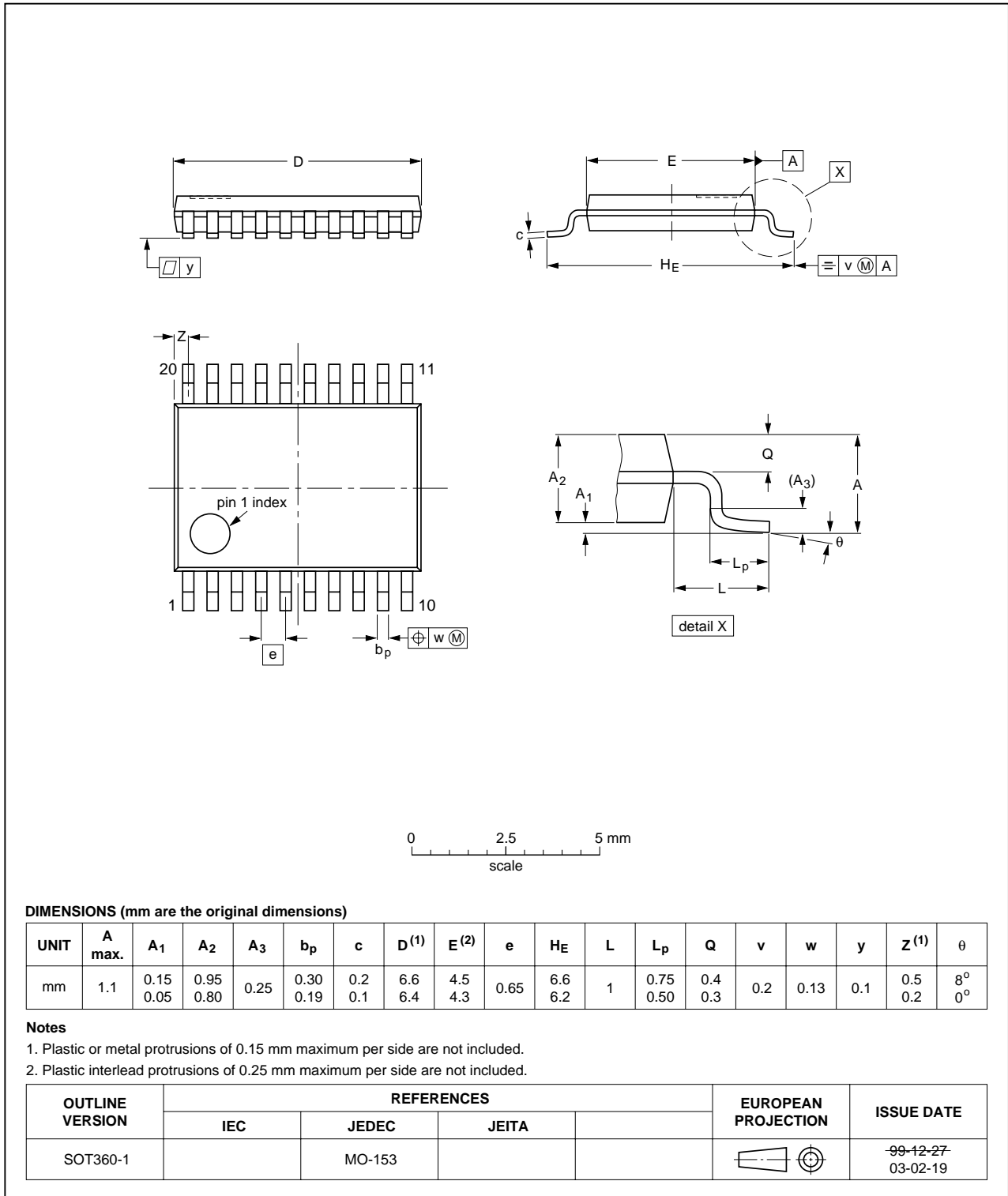

Fig 14. Package outline SOT360-1 (TSSOP20)

## 13. Abbreviations

Table 10. Abbreviations

Acronym	Description
CMOS	Complementary Metal Oxide Semiconductor
DUT	Device Under Test
ESD	ElectroStatic Discharge
HBM	Human Body Model
MM	Machine Model
TTL	Transistor-Transistor Logic

## 14. Revision history

Table 11. Revision history

Document ID	Release date	Data sheet status	Change notice	Supersedes
74LV574_4	20090514	Product data sheet	-	74LV574_3
Modifications:	• Typo removed from <a href="#">Figure 8</a> and <a href="#">Table 8</a> adapted accordingly			
74LV574_3	20090416	Product data sheet	-	74LV574_2
74LV574_2	19970203	Product specification	-	74LV574_1
74LV574_1	19980610	Product specification	-	-

## 15. Legal information

### 15.1 Data sheet status

Document status <sup>[1][2]</sup>	Product status <sup>[3]</sup>	Definition
Objective [short] data sheet	Development	This document contains data from the objective specification for product development.
Preliminary [short] data sheet	Qualification	This document contains data from the preliminary specification.
Product [short] data sheet	Production	This document contains the product specification.

[1] Please consult the most recently issued document before initiating or completing a design.

[2] The term 'short data sheet' is explained in section "Definitions".

[3] The product status of device(s) described in this document may have changed since this document was published and may differ in case of multiple devices. The latest product status information is available on the Internet at URL <http://www.nxp.com>.

### 15.2 Definitions

**Draft** — The document is a draft version only. The content is still under internal review and subject to formal approval, which may result in modifications or additions. NXP Semiconductors does not give any representations or warranties as to the accuracy or completeness of information included herein and shall have no liability for the consequences of use of such information.

**Short data sheet** — A short data sheet is an extract from a full data sheet with the same product type number(s) and title. A short data sheet is intended for quick reference only and should not be relied upon to contain detailed and full information. For detailed and full information see the relevant full data sheet, which is available on request via the local NXP Semiconductors sales office. In case of any inconsistency or conflict with the short data sheet, the full data sheet shall prevail.

### 15.3 Disclaimers

**General** — Information in this document is believed to be accurate and reliable. However, NXP Semiconductors does not give any representations or warranties, expressed or implied, as to the accuracy or completeness of such information and shall have no liability for the consequences of use of such information.

**Right to make changes** — NXP Semiconductors reserves the right to make changes to information published in this document, including without limitation specifications and product descriptions, at any time and without notice. This document supersedes and replaces all information supplied prior to the publication hereof.

**Suitability for use** — NXP Semiconductors products are not designed, authorized or warranted to be suitable for use in medical, military, aircraft, space or life support equipment, nor in applications where failure or malfunction of an NXP Semiconductors product can reasonably be expected to result in personal injury, death or severe property or environmental

damage. NXP Semiconductors accepts no liability for inclusion and/or use of NXP Semiconductors products in such equipment or applications and therefore such inclusion and/or use is at the customer's own risk.

**Applications** — Applications that are described herein for any of these products are for illustrative purposes only. NXP Semiconductors makes no representation or warranty that such applications will be suitable for the specified use without further testing or modification.

**Limiting values** — Stress above one or more limiting values (as defined in the Absolute Maximum Ratings System of IEC 60134) may cause permanent damage to the device. Limiting values are stress ratings only and operation of the device at these or any other conditions above those given in the Characteristics sections of this document is not implied. Exposure to limiting values for extended periods may affect device reliability.

**Terms and conditions of sale** — NXP Semiconductors products are sold subject to the general terms and conditions of commercial sale, as published at <http://www.nxp.com/profile/terms>, including those pertaining to warranty, intellectual property rights infringement and limitation of liability, unless explicitly otherwise agreed to in writing by NXP Semiconductors. In case of any inconsistency or conflict between information in this document and such terms and conditions, the latter will prevail.

**No offer to sell or license** — Nothing in this document may be interpreted or construed as an offer to sell products that is open for acceptance or the grant, conveyance or implication of any license under any copyrights, patents or other industrial or intellectual property rights.

**Export control** — This document as well as the item(s) described herein may be subject to export control regulations. Export might require a prior authorization from national authorities.

### 15.4 Trademarks

Notice: All referenced brands, product names, service names and trademarks are the property of their respective owners.

## 16. Contact information

For more information, please visit: <http://www.nxp.com>

For sales office addresses, please send an email to: [salesaddresses@nxp.com](mailto:salesaddresses@nxp.com)

## 17. Contents

<b>1</b>	<b>General description</b> .....	<b>1</b>
<b>2</b>	<b>Features</b> .....	<b>1</b>
<b>3</b>	<b>Ordering information</b> .....	<b>1</b>
<b>4</b>	<b>Functional diagram</b> .....	<b>2</b>
<b>5</b>	<b>Pinning information</b> .....	<b>3</b>
5.1	Pinning .....	3
5.2	Pin description .....	3
<b>6</b>	<b>Functional description</b> .....	<b>4</b>
<b>7</b>	<b>Limiting values</b> .....	<b>4</b>
<b>8</b>	<b>Recommended operating conditions</b> .....	<b>5</b>
<b>9</b>	<b>Static characteristics</b> .....	<b>5</b>
<b>10</b>	<b>Dynamic characteristics</b> .....	<b>6</b>
<b>11</b>	<b>Waveforms</b> .....	<b>8</b>
<b>12</b>	<b>Package outline</b> .....	<b>11</b>
<b>13</b>	<b>Abbreviations</b> .....	<b>15</b>
<b>14</b>	<b>Revision history</b> .....	<b>15</b>
<b>15</b>	<b>Legal information</b> .....	<b>16</b>
15.1	Data sheet status .....	16
15.2	Definitions .....	16
15.3	Disclaimers .....	16
15.4	Trademarks .....	16
<b>16</b>	<b>Contact information</b> .....	<b>16</b>
<b>17</b>	<b>Contents</b> .....	<b>17</b>

Please be aware that important notices concerning this document and the product(s) described herein, have been included in section 'Legal information'.



© NXP B.V. 2009.

All rights reserved.

For more information, please visit: <http://www.nxp.com>

For sales office addresses, please send an email to: [salesaddresses@nxp.com](mailto:salesaddresses@nxp.com)

Date of release: 14 May 2009

Document identifier: 74LV574\_4

## Looking for pricing, stock, or lifecycle information?

Click below to explore more details on WIN SOURCE:

- [View 74LV574PW,118 on WIN SOURCE](#)
- [NXP / Nexperia Information](#)

## Optimize Your Supply Chain with WIN SOURCE Solutions

- ✓ Global Sourcing Solution
- ✓ Obsolete Management
- ✓ Cost Control Management
- ✓ Shortage Management
- ✓ Alternative Solution
- ✓ Excess Inventory Management