



**THE DATASHEET OF
ST2G3236QTR**





ST2G3236

2-bit dual supply bus transceiver level translator with side series resistor

Features

- High speed:
 - $t_{PD} = 6.2 \text{ ns}$ (max) at $T_A = 85 \text{ }^\circ\text{C}$
 - $V_{CCB} = 1.8 \text{ V}$
 - $V_{CCA} = 3.3 \text{ V}$
- Low power dissipation:
 - $I_{CCA} = I_{CCB} = 5 \text{ } \mu\text{A}$ (max) at $T_A = 85 \text{ }^\circ\text{C}$
- Symmetrical output impedance:
 - $|I_{OHA}| = I_{OLA} = 7 \text{ mA}$ min at $V_{CCA} = 2.75 \text{ V}$; $V_{CCB} = 1.65 \text{ V}$ or 2.3 V
 - $|I_{OHB}| = I_{OLB} = 2 \text{ mA}$ min at $V_{CCA} = 2.3 \text{ V}$ or 3.0 V ; $V_{CCB} = 1.65 \text{ V}$
- Balanced propagation delays:
 - $T_{PLH} \approx T_{PHL}$
- Power-down protection on inputs and outputs
- $26 \text{ } \Omega$ series resistor on A side
- Operating voltage range:
 - $V_{CCA} \text{ (OPR)} = 1.4 \text{ V to } 3.6 \text{ V}$
 - $V_{CCB} \text{ (OPR)} = 1.4 \text{ V to } 3.6 \text{ V}$
- Max data rates:
 - 380 Mbps (1.8 V to 3.3 V translation)
 - 260 Mbps (<1.8 V to 3.3 V translation)
 - 260 Mbps (translate to 2.5 V)
 - 210 Mbps (translate to 1.5 V)
- Latch-up performance exceeds 500 mA (JESD17)
- ESD performance:
 - HBM > 2 kV (MIL STD 883 method 3015)
 - MM > 200 V

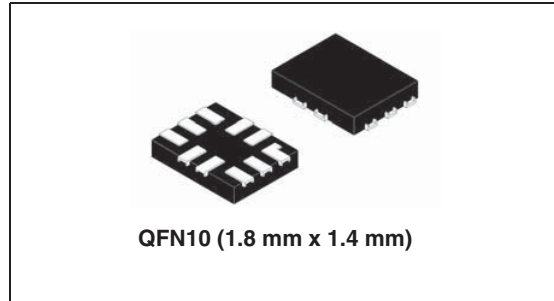

Description

The ST2G3236 is a dual supply, low-voltage CMOS 2-bit bus transceiver produced with sub-micron silicon gate and five-layer metal wiring C²MOS technology. Designed for use as an interface between a 3.3 V bus and a 2.5 V or 1.8 V bus in mixed 3.3 V/1.8 V, 3.3 V/2.5 V and 2.5 V/1.8 V supply systems, it achieves high speed operation while maintaining the CMOS low power dissipation.

This IC is intended for two-way asynchronous communication between data buses, and the direction of data transmission is determined by DIR inputs. The A-port interfaces with the 3 V bus, and the B-port with the 2.5 V and 1.8 V bus.

All inputs are equipped with protection circuits to protect against static discharge, giving them 2 kV of ESD immunity and transient excess voltage.

Table 1. Device summary

Part number	Package	Packaging
ST2G3236	QFN10 (1.8 mm x 1.4 mm)	Tape and reel

Contents

1	Logic diagram and I/O equivalent circuit	5
1.1	Truth table	6
1.2	Application notes and recommendations	6
1.3	Recommended power-up sequence	6
1.4	Recommended power-down sequence	6
2	Pin connections and descriptions	7
2.1	Pin connections	7
2.2	Pin descriptions	7
3	Electrical ratings	8
4	Electrical characteristics	9
4.1	DC electrical characteristics for V_{CCA}	9
4.2	DC electrical characteristics for V_{CCB}	10
4.3	AC electrical characteristics	12
4.4	Capacitance characteristics	13
5	Test circuit	14
6	Waveforms	15
7	Package mechanical data	16
8	Revision history	21

List of tables

Table 1.	Device summary	1
Table 2.	Truth table	6
Table 3.	Pin descriptions	7
Table 4.	Absolute maximum ratings	8
Table 5.	Recommended operating conditions	8
Table 6.	DC specification for V_{CCA}	9
Table 7.	DC specification for V_{CCB}	10
Table 8.	AC electrical characteristics	12
Table 9.	Capacitance characteristics	13
Table 10.	Test values	14
Table 11.	Waveform symbol value	15
Table 12.	QFN10L (1.8 mm x 1.4 mm) mechanical data	17
Table 13.	Revision history	21

List of figures

Figure 1.	Logic diagram	5
Figure 2.	I/O equivalent circuit	5
Figure 3.	Pin connections (top through view)	7
Figure 4.	Test circuit	14
Figure 5.	Waveform - propagation delay (f = 1 MHz, 50% duty cycle)	15
Figure 6.	Waveform - output enable and disable time (f = 1 MHz, 50% duty cycle)	15
Figure 7.	QFN10L (1.8 mm x 1.4 mm) package mechanical outline	17
Figure 8.	QFN10L (1.8 mm x 1.4 mm) footprint recommendation	18
Figure 9.	QFN10L (1.8 mm x 1.4 mm) carrier tape	18
Figure 10.	QFN10L (1.8 mm x 1.4 mm) reel information - back view	19
Figure 11.	QFN10L (1.8 mm x 1.4 mm) reel information - front view	20

1 Logic diagram and I/O equivalent circuit

Figure 1. Logic diagram

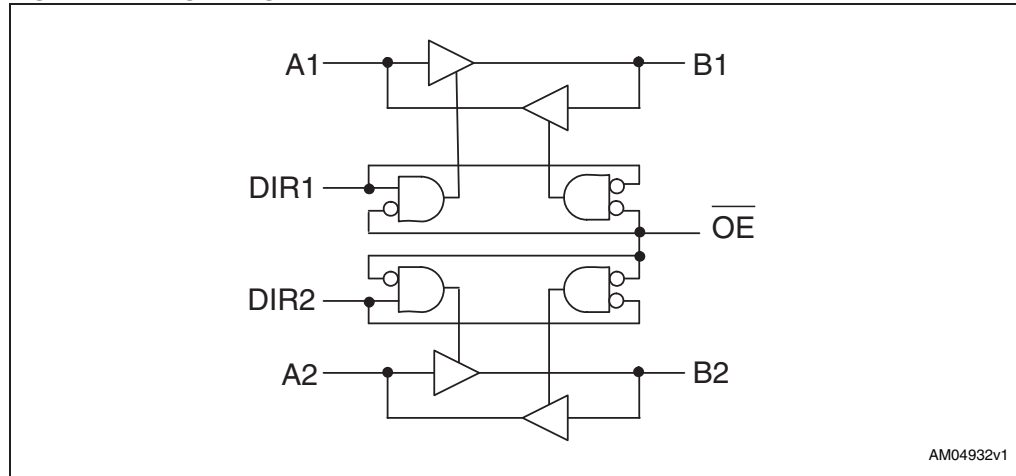
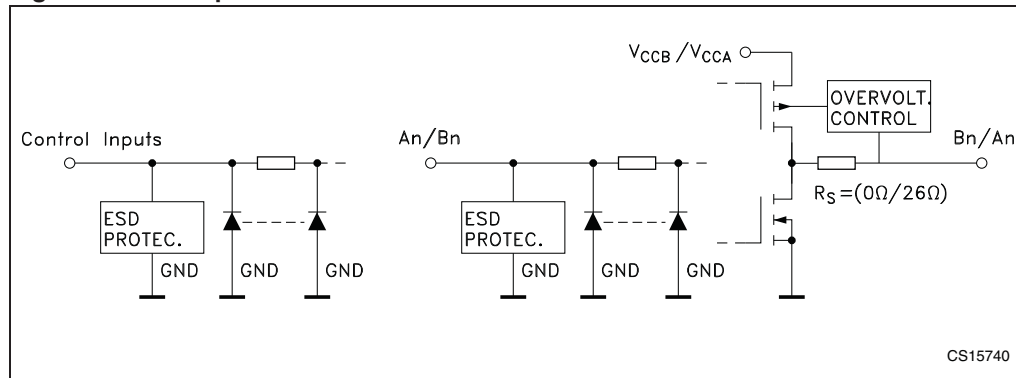

Figure 2. I/O equivalent circuit



1.1 Truth table

Table 2. Truth table

Inputs		Function		Output
\overline{OE}	DIRn	A BUS	B BUS	
L	L	Output	Input	B => A
L	H	Input	Output	B <= A
H	X	High-Z	High-Z	HIGH-Z

1.2 Application notes and recommendations

- Once the device is enabled ($\overline{OE} = \text{low}$), even if the input is floating, output may be either on high or low logic level only, not in a high-impedance state. Output is in a high-impedance state only when $\overline{OE} = \text{high}$.
- Unused I/O channel should be connected to GND or to the corresponding supply.
- The \overline{OE} and DIRn block is powered by V_{CCB} and these input logic levels are referenced to V_{CCB} . The \overline{OE} and DIRn input high level can be equal to or greater than V_{CCB} , up to $V_{IHB \text{ max}}$.
- Any input high level can be higher than the corresponding input supply voltage, up to $V_{IHA \text{ max}}$ ($V_{IHB \text{ max}}$).

Example:

$V_{CCA} = 1.8 \text{ V}$, $V_{CCB} = 2.6 \text{ V}$, $\overline{OE} = \text{Low}$, DIRn = Low (B → A direction)

==> if I/O Bn = 3 V, I/O An = 1.8 V

- If $V_{CCA} = V_{CCB} = 0 \text{ V}$ and $\overline{OE} = 0 \text{ V}$, An and Bn are isolated even if there is a signal on An or Bn.
- If the ST2G3236QTR is used in a UART application, there is a possibility of floating input condition if the cable is disconnected, therefore a pull-down resistor is recommended on the input port.

1.3 Recommended power-up sequence

- Apply power to either V_{CC} .
- Apply power to the \overline{OE} input and to the respective data inputs. This may occur at the same time as step 1.
- Apply power to the other V_{CC} .
- Drive the \overline{OE} input LOW to enable the device.

1.4 Recommended power-down sequence

- Drive the \overline{OE} input HIGH to disable the device.
- Remove power from either V_{CC} .
- Remove power from the other V_{CC} .

2 Pin connections and descriptions

2.1 Pin connections

Figure 3. Pin connections (top through view)

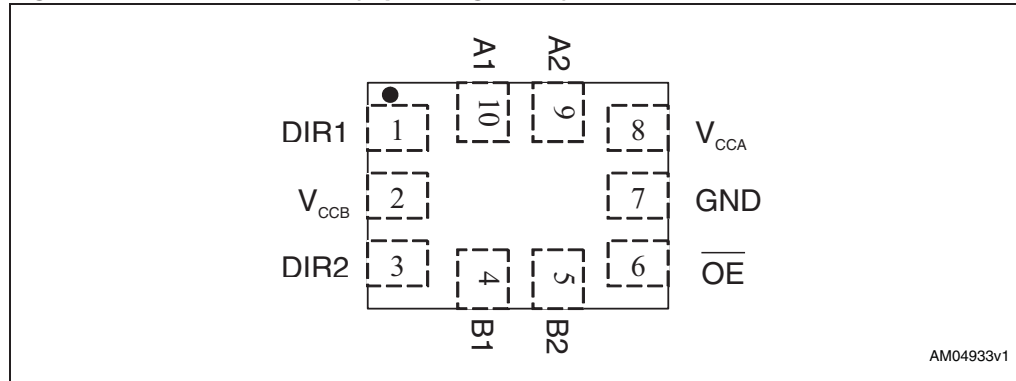

2.2 Pin descriptions

Table 3. Pin descriptions

Pin	Symbol	Name and function
1, 3	DIR1, DIR2	Directional controls
10	A1	Data inputs/outputs
4	B1	Data outputs/inputs
9	A2	Data inputs/outputs
5	B2	Data outputs/inputs
7	GND	Ground (0 V)
8	V _{CCA}	Positive supply voltage
2	V _{CCB}	Positive supply voltage
6	$\overline{\text{OE}}$	Output enable (active low)

3 Electrical ratings

Stressing the device above the rating listed in the absolute maximum ratings table may cause permanent damage to the device. These are stress ratings only and operation of the device at these or any other conditions above those indicated in the operating sections of this specification is not implied. Exposure to absolute maximum rating conditions for extended periods may affect device reliability.

Table 4. Absolute maximum ratings

Symbol	Parameter	Value	Unit
V_{CCA}	Supply voltage	-0.5 to 4.6	V
V_{CCB}	Supply voltage	-0.5 to 4.6	V
V_I	DC input voltage	-0.5 to 4.6	V
$V_{I/OA}$	DC I/O voltage (output disabled)	-0.5 to 4.6	V
$V_{I/OB}$	DC I/O voltage (output disabled)	-0.5 to 4.6	V
$V_{I/OA}$	DC output voltage	-0.5 to $V_{CCA} + 0.5$	V
$V_{I/OB}$	DC output voltage	-0.5 to $V_{CCB} + 0.5$	V
I_{IK}	DC input diode current	-20	mA
I_{OK}	DC output diode current	-50	mA
I_{OA}	DC output current	± 50	mA
I_{OB}	DC output current	± 50	mA
I_{CCA}	DC V_{CC} or ground current	± 100	mA
I_{CCB}	DC V_{CC} or ground current	± 100	mA
P_D	Power dissipation	200	mW
T_{stg}	Storage temperature	-65 to +150	$^{\circ}\text{C}$
T_L	Lead temperature (10 s)	260	$^{\circ}\text{C}$

Table 5. Recommended operating conditions

Symbol	Parameter	Value	Unit	
V_{CCA}	Supply voltage	1.4 to 3.6	V	
V_{CCB}	Supply voltage	1.4 to 3.6	V	
V_I	Input voltage (DIRn, \overline{OE})	0 to V_{CCB}	V	
$V_{I/OA}$	I/O voltage	0 to V_{CCA}	V	
$V_{I/OB}$	I/O voltage	0 to V_{CCB}	V	
T_{op}	Operating temperature	-40 to +85	$^{\circ}\text{C}$	
dt/dv	Input rise and fall time ⁽¹⁾	$V_{CCB} = 3.0$ to 3.6 V	0 to 10	ns/V
		$V_{CCB} = 2.3$ to 2.7 V	0 to 20	ns/V
		$V_{CCB} = 1.4$ to 1.95 V	0 to 100	ns/V

1. V_{IN} from 0.8 V to 2.0 V at $V_{CC} = 3.0$ V

4 Electrical characteristics

4.1 DC electrical characteristics for V_{CCA}

Table 6. DC specification for V_{CCA}

Sym.	Parameter	Test conditions			Value				Unit
		$V_{CCB}^{(1)}$ (V)	$V_{CCA}^{(1)}$ (V)		$T_A = 25\text{ }^\circ\text{C}$		$-40\text{ to }85\text{ }^\circ\text{C}$		
					Min	Max	Min	Max	
V_{IHA}	High level input voltage (An)	1.4 to 3.3 V	1.4		$0.65V_{CCA}$	3.6	$0.65V_{CCA}$	3.6	V
			1.8		$0.65V_{CCA}$		$0.65V_{CCA}$		
			2.5		1.6		1.6		
			3.3		2.0		2.0		
V_{ILA}	Low level input voltage (An)	1.4 to 3.3 V	1.4			$0.35V_{CCA}$		$0.35V_{CCA}$	V
			1.8			$0.35V_{CCA}$		$0.35V_{CCA}$	
			2.5			0.7		0.7	
			3.3			0.8		0.8	
V_{OHA}	High level output voltage	1.4 to 3.3 V	1.4	$I_O = -100\text{ }\mu\text{A}$	1.2		1.2		V
			2.75	$I_O = -0.4\text{ mA}$	2.5		2.5		
			2.75	$I_O = -7\text{ mA}$	2.2		2.2		
			2.3	$I_O = -5\text{ mA}$	1.8		1.8		
			1.65	$I_O = -2\text{ mA}$	1.4		1.4		
			1.4	$I_O = -1\text{ mA}$	1.1		1.1		
V_{OLA}	Low level output voltage	1.4 to 3.3 V	1.4	$I_O = 100\text{ }\mu\text{A}$		0.20		0.20	V
			2.75	$I_O = 1\text{ mA}$		0.40		0.40	
			2.75	$I_O = 7\text{ mA}$		0.55		0.55	
			2.3	$I_O = 5\text{ mA}$		0.40		0.40	
			1.65	$I_O = 2\text{ mA}$		0.25		0.25	
			1.4	$I_O = 1\text{ mA}$		0.20		0.20	
I_{IA}	Input leakage current	2.7	3.3	$V_I = V_{CC}$ or GND		± 0.5		± 5	μA
		1.4	2.7	$V_I = 3.6\text{V}$ or GND		± 0.5		± 5	
I_{OZA}	High impedance output leakage current	2.7	3.3	$V_{IA} = \text{GND}$ or 3.6 V $V_{IB} = V_{IHB}$ or V_{ILB} $\overline{OE} = V_{CCB}$		± 1.0		± 10	μA

Table 6. DC specification for V_{CCA} (continued)

Sym.	Parameter	Test conditions			Value				Unit
		$V_{CCB}^{(1)}$ (V)	$V_{CCA}^{(1)}$ (V)		$T_A = 25\text{ }^\circ\text{C}$		$-40\text{ to }85\text{ }^\circ\text{C}$		
					Min	Max	Min	Max	
I_{OFF}	Power OFF leakage current	0	0	$V_{IA}=\text{GND to }3.6\text{ V}$ $V_{IB}=\text{GND to }3.6\text{ V}$ $\overline{OE}, \text{ DIR}=\text{GND to }3.6\text{ V}$		± 1.0		± 10	μA
I_{CCA}	Quiescent supply current	1.95	2.7	$V_{IA}=V_{CCA}\text{ or GND}$ $V_{IB}=V_{CCB}\text{ or GND}$		0.5		5	μA
		1.95	3.3						
		2.7	3.3						
ΔI_{CCA}	Maximum quiescent supply current / input (An)	1.95	2.7	$V_{IA}=V_{CCA}-0.6\text{ V}$ $V_{IB}=V_{CCB}\text{ or GND}$				0.75	mA
		1.95	3.3						
		2.7	3.3						

1. V_{CC} range = 3.3 ± 0.3 ; $2.5 \pm 0.2\text{ V}$; $1.8 \pm 0.15\text{ V}$

4.2 DC electrical characteristics for V_{CCB}

Table 7. DC specification for V_{CCB}

Sym.	Parameter	Test conditions			Value				Unit
		$V_{CCB}^{(1)}$ (V)	$V_{CCA}^{(1)}$ (V)		$T_A = 25\text{ }^\circ\text{C}$		$-40\text{ to }85\text{ }^\circ\text{C}$		
					Min	Max	Min	Max	
V_{IHB}	High level input voltage (Bn, DIRn, OE)	1.4	1.4 to 3.3 V		$0.65V_{CCB}$	3.6	$0.65V_{CCB}$	3.6	V
		1.8			$0.65V_{CCB}$		$0.65V_{CCB}$		
		2.5			1.6		1.6		
		3.3			2.0		2.0		
V_{ILB}	Low level input voltage (Bn, DIRn, OE)	1.4	1.4 to 3.3 V		$0.35V_{CCB}$		$0.35V_{CCB}$	V	
		1.8			$0.35V_{CCB}$	$0.35V_{CCB}$			
		2.5			0.7	0.7			
		3.3			0.8	0.8			

Table 7. DC specification for V_{CCB} (continued)

Sym.	Parameter	Test conditions			Value				Unit
		$V_{CCB}^{(1)}$ (V)	$V_{CCA}^{(1)}$ (V)		$T_A = 25^\circ\text{C}$		$-40 \text{ to } 85^\circ\text{C}$		
					Min	Max	Min	Max	
V_{OHB}	High level output voltage	1.4	1.4 to 3.3 V	$I_O = -100 \mu\text{A}$	1.3		1.3		V
		1.8		$I_O = -100 \mu\text{A}$	1.6		1.6		
		2.75		$I_O = -20 \text{ mA}$	2.2		2.2		
		2.75		$I_O = -15 \text{ mA}$	1.7		1.7		
		2.3		$I_O = -4 \text{ mA}$	1.44		1.44		
		1.65		$I_O = -2 \text{ mA}$	1.5		1.5		
		1.4		$I_O = -2 \text{ mA}$	1.25		1.25		
V_{OLB}	Low level output voltage	1.4	1.4 to 3.3 V	$I_O = 100 \mu\text{A}$		0.1		0.1	V
		1.8		$I_O = 100 \mu\text{A}$		0.2		0.2	
		2.75		$I_O = 20 \text{ mA}$		0.55		0.55	
		2.75		$I_O = 15 \text{ mA}$		0.35		0.35	
		2.3		$I_O = 4 \text{ mA}$		0.39		0.39	
		1.65		$I_O = 2 \text{ mA}$		0.20		0.20	
		1.4		$I_O = 2 \text{ mA}$		0.15		0.15	
I_{IB}	Input leakage current	2.7	3.3	$V_I = V_{CC}$ or GND		± 0.5		± 5	μA
		1.4	2.7	$V_I = 3.6 \text{ V}$ or GND		± 0.5		± 5	
I_{OZB}	High impedance output leakage current	2.7	3.3	$V_{IA} = V_{IHA}$ or V_{ILA} $V_{IB} = \text{GND}$ or 3.6 V $\overline{OE} = V_{CCB}$		± 1.0		± 10	μA
I_{CCIB}	Quiescent supply current	1.95	2.7	$V_{IA} = V_{CCA}$ or GND $V_{IB} = V_{CCB}$ or GND		0.5		5	μA
		1.95	3.3						
		2.7	3.3						
ΔI_{CCIB}	Maximum quiescent supply current / input (B_n , DIR_n , \overline{OE})	1.95	2.7	$V_{IB} = V_{CCB} - 0.6 \text{ V}$ $V_{IA} = V_{CCA}$ or GND				0.75	mA
		1.95	3.3						
		2.7	3.3						

1. V_{CC} range = 3.3 ± 0.3 ; $2.5 \pm 0.2 \text{ V}$; $1.8 \pm 0.15 \text{ V}$

4.3 AC electrical characteristics

Table 8. AC electrical characteristics

Symbol	Parameter	Test condition			Value		Unit
		V_{CCB} (V)	V_{CCA} (V)		-40 to 85 °C		
					Min	Max	
t_{PLH} t_{PHL}	Propagation delay time An to Bn	1.8 ± 0.15	2.5 ± 0.2	$C_L = 30$ pF $R_L = 500$ Ω	1.0	5.8	ns
		1.8 ± 0.15	3.3 ± 0.3		1.0	6.2	
		2.5 ± 0.2	3.3 ± 0.3		1.0	4.4	
t_{PLH} t_{PHL}	Propagation delay time Bn to An	1.8 ± 0.15	2.5 ± 0.2	$C_L = 30$ pF $R_L = 500$ Ω	1.0	5.5	ns
		1.8 ± 0.15	3.3 ± 0.3		1.0	5.1	
		2.5 ± 0.2	3.3 ± 0.3		1.0	4.0	
t_{PZL} t_{PZH}	Output enable time \overline{OE} to An	1.8 ± 0.15	2.5 ± 0.2	$C_L = 30$ pF $R_L = 500$ Ω	1.0	5.4	ns
		1.8 ± 0.15	3.3 ± 0.3		1.0	5.1	
		2.5 ± 0.2	3.3 ± 0.3		1.0	4.0	
t_{PZL} t_{PZH}	Output enable time \overline{OE} to Bn	1.8 ± 0.15	2.5 ± 0.2	$C_L = 30$ pF $R_L = 500$ Ω	1.0	5.3	ns
		1.8 ± 0.15	3.3 ± 0.3		1.0	5.2	
		2.5 ± 0.2	3.3 ± 0.3		1.0	4.6	
t_{PLZ} t_{PHZ}	Output disable time \overline{OE} to An	1.8 ± 0.15	2.5 ± 0.2	$C_L = 30$ pF $R_L = 500$ Ω	1.0	5.2	ns
		1.8 ± 0.15	3.3 ± 0.3		1.0	5.6	
		2.5 ± 0.2	3.3 ± 0.3		1.0	4.8	
t_{PLZ} t_{PHZ}	Output disable time \overline{OE} to Bn	1.8 ± 0.15	2.5 ± 0.2	$C_L = 30$ pF $R_L = 500$ Ω	1.0	4.6	ns
		1.8 ± 0.15	3.3 ± 0.3		1.0	4.5	
		2.5 ± 0.2	3.3 ± 0.3		1.0	4.4	
t_{OSLH} t_{OSHL}	Output to output skew time ⁽¹⁾ ⁽²⁾	1.8 ± 0.15	2.5 ± 0.2	$C_L = 30$ pF $R_L = 500$ Ω		0.5	ns
		1.8 ± 0.15	3.3 ± 0.3			0.5	
		2.5 ± 0.2	3.3 ± 0.3			0.75	

- Skew is defined as the absolute value of the difference between the actual propagation delay for any two outputs of the same device switching in the same direction, either HIGH or LOW ($t_{OSLh} = |t_{PLHm} - t_{PLHn}|$, $t_{OSLl} = |t_{PHLm} - t_{PHLn}|$)
- Parameter guaranteed by design

4.4 Capacitance characteristics

Table 9. Capacitance characteristics

Symbol	Parameter	Test condition			Value					Unit
		V _{CCB} (V)	V _{CCA} (V)		T _A = 25 °C			-40 to 85 °C		
					Min.	Typ.	Max.	Min.	Max.	
C _{INB}	Input capacitance	Open	Open		-	5	-	-	-	pF
C _{I/O}	Input/output capacitance	2.5	3.3		-	6	-	-	-	pF
C _{PD} ⁽¹⁾	Power dissipation capacitance	2.5	3.3	f=10 MHz	-	29	-	-	-	pF
		1.8	3.3		-	29	-	-	-	

1. C_{PD} is defined as the value of the IC's internal equivalent capacitance, which is calculated from the operating current consumption without load. (Refer to [Figure 4: Test circuit](#)). Average current can be obtained by the following equation. I_{CC(opr)} - C_{PD} × V_{CC} × f_{IN} + I_{CC}/16 (per circuit)

5 Test circuit

Figure 4. Test circuit

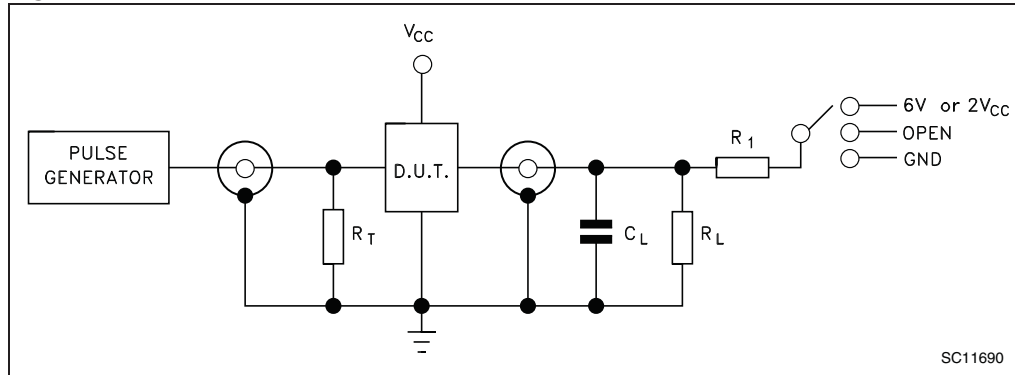

Table 10. Test values

Test	Switch
t_{PLH} , t_{PHL}	Open
t_{PZL} , t_{PLZ} ($V_{CC} = 3.0$ to 3.6 V)	6 V
t_{PZL} , t_{PLZ} ($V_{CC} = 2.3$ to 2.7 V or $V_{CC} = 1.6$ to 1.95 V)	$2V_{CC}$
t_{PZH} , t_{PHZ}	GND

6 Waveforms

Table 11. Waveform symbol value

Symbol	V _{CC}		
	3.0 to 3.6V	2.3 to 2.7V	1.65 to 1.95V
V _{IH}	V _{CC}	V _{CC}	V _{CC}
V _M	1.5V	V _{CC} /2	V _{CC} /2
V _X	V _{OL} + 0.3V	V _{OL} + 0.15V	V _{OL} + 0.15V
V _Y	V _{OL} - 0.3V	V _{OL} - 0.15V	V _{OL} - 0.15V

- C_L = 30 pF or equivalent (includes jig and probe capacitance)
- R_L = R₁ = 500 Ω or equivalent
- R_T = Z_{OUT} of pulse generator (typically 50 Ω)

Figure 5. Waveform - propagation delay (f = 1 MHz, 50% duty cycle)

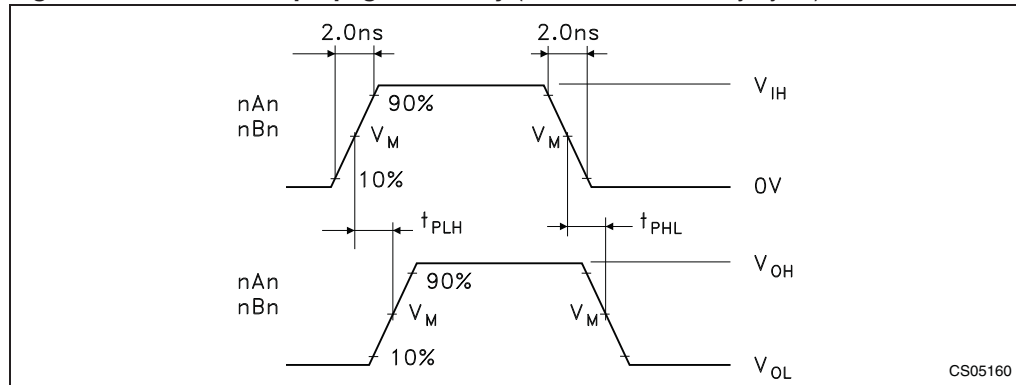
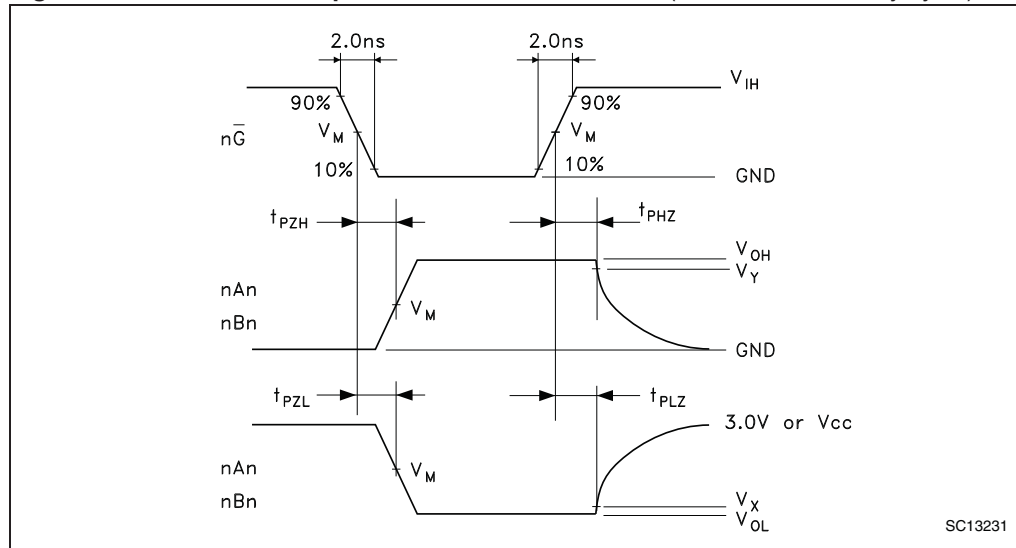

Figure 6. Waveform - output enable and disable time (f = 1 MHz, 50% duty cycle)



7 Package mechanical data

In order to meet environmental requirements, ST offers these devices in different grades of ECOPACK[®] packages, depending on their level of environmental compliance. ECOPACK[®] specifications, grade definitions and product status are available at: www.st.com. ECOPACK[®] is an ST trademark.

Table 12. QFN10L (1.8 mm x 1.4 mm) mechanical data

ref.	mm			inch		
	Nom	Min	Max	Nom	Min	Max
A	0.50	0.45	0.55	0.020	0.017	0.021
A1	0.02	0	0.05	0.001	0	0.002
A3	0.127			0.005	0	0
b	0.20	0.15	0.25	0.007	0.006	0.010
D	1.80	1.70	1.90	0.070	0.066	0.074
E	1.40	1.30	1.50	0.055	0.051	0.059
e	0.40			0.015		
L	0.40	0.30	0.50	0.015	0.011	0.020

Figure 7. QFN10L (1.8 mm x 1.4 mm) package mechanical outline

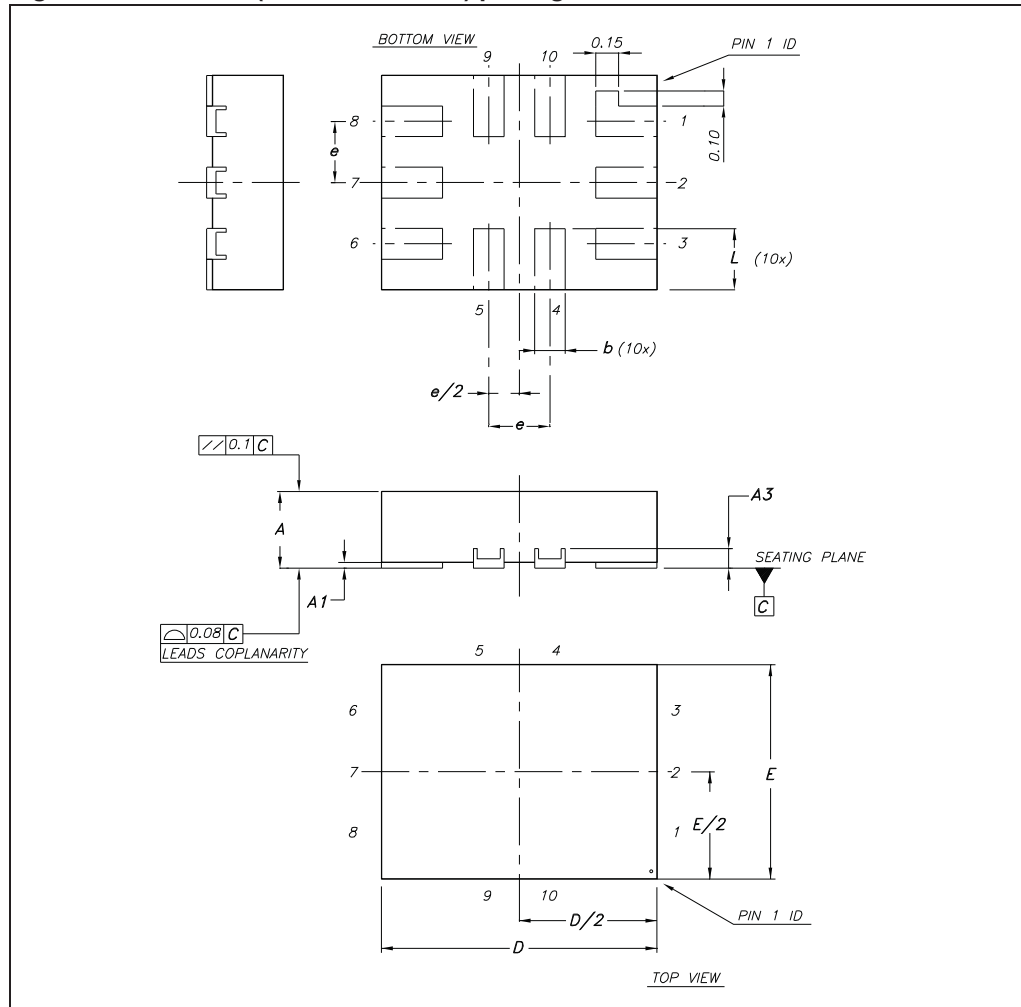

Figure 8. QFN10L (1.8 mm x 1.4 mm) footprint recommendation

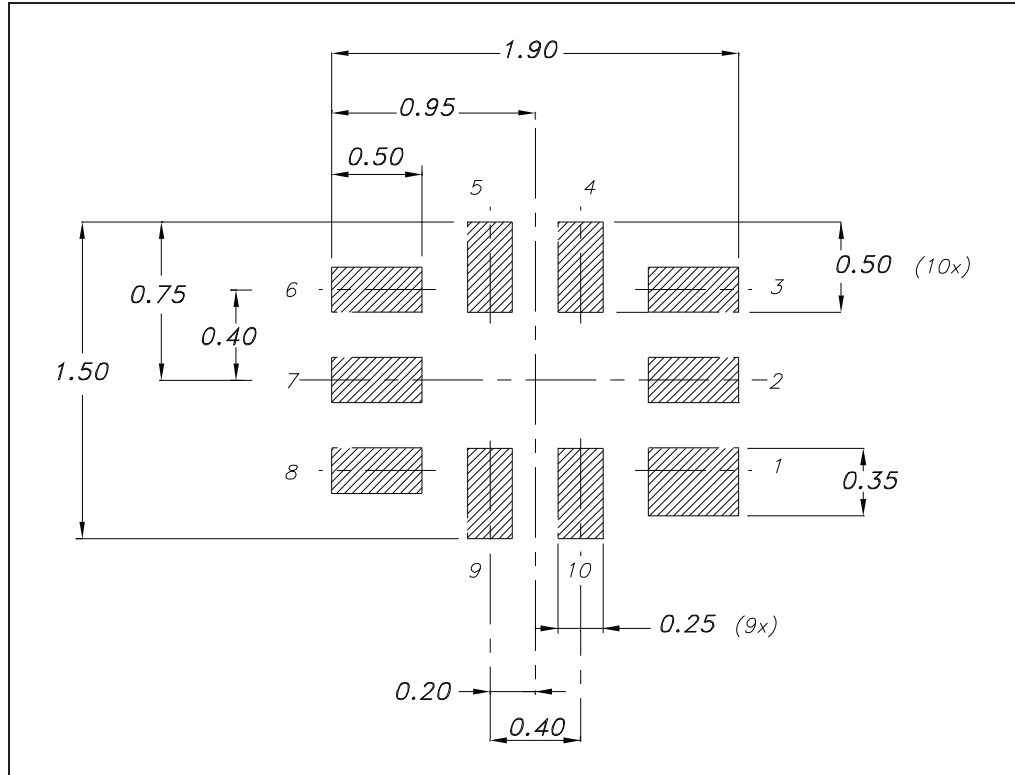

Figure 9. QFN10L (1.8 mm x 1.4 mm) carrier tape

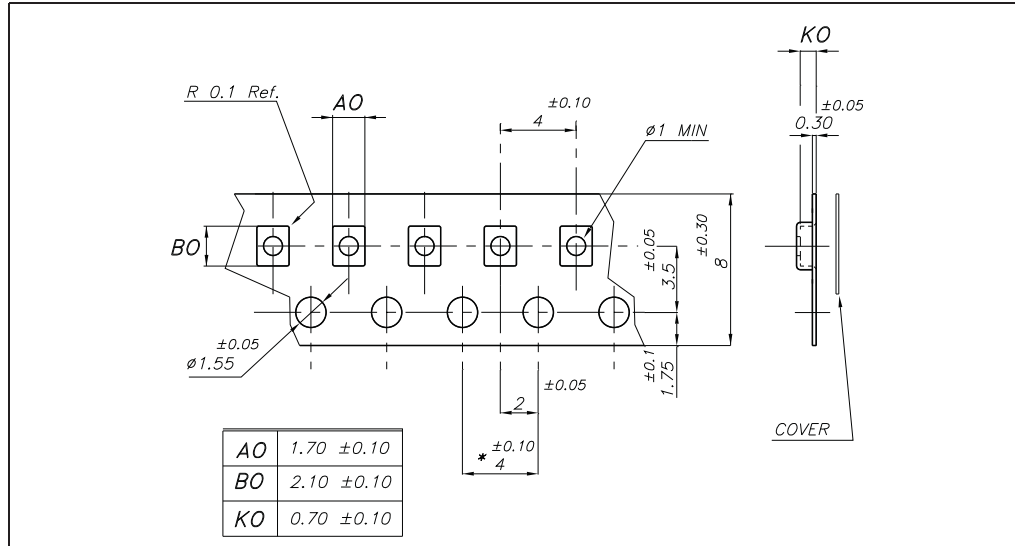
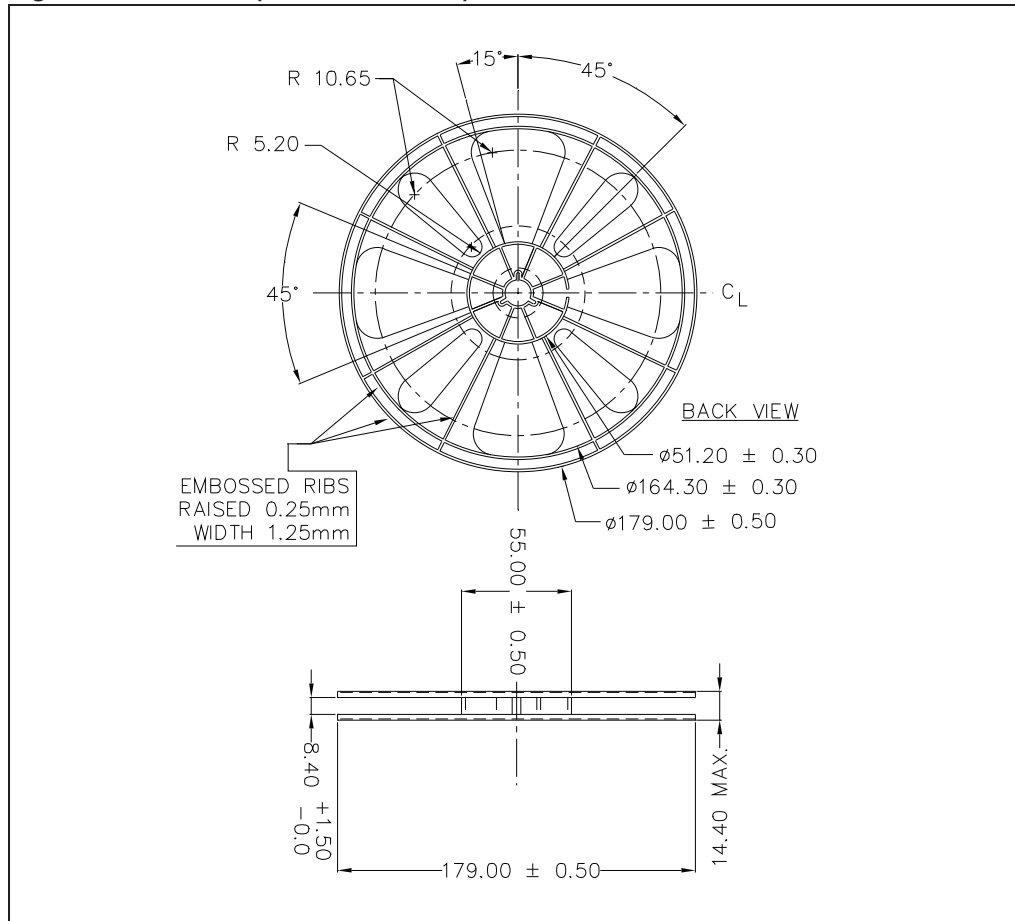

Figure 10. QFN10L (1.8 mm x 1.4 mm) reel information - back view



8 Revision history

Table 13. Revision history

Date	Revision	Changes
06-Dec-2006	1	First release
31-Mar-2010	2	Corrected the value for V_I in Table 5: Recommended operating conditions , from “0 to V_{CCA} ” to “0 to V_{CCB} ”. Minor formatting and text changes throughout the document.
21-Apr-2010	3	Added footnote to Table 4: Absolute maximum ratings on page 8 .
23-Jul-2010	4	Updated Figure 1 , Section 3 , Table 6 , 7 ; added Section 1.2 ; reformatted document; minor textual changes.

Please Read Carefully:

Information in this document is provided solely in connection with ST products. STMicroelectronics NV and its subsidiaries ("ST") reserve the right to make changes, corrections, modifications or improvements, to this document, and the products and services described herein at any time, without notice.

All ST products are sold pursuant to ST's terms and conditions of sale.

Purchasers are solely responsible for the choice, selection and use of the ST products and services described herein, and ST assumes no liability whatsoever relating to the choice, selection or use of the ST products and services described herein.

No license, express or implied, by estoppel or otherwise, to any intellectual property rights is granted under this document. If any part of this document refers to any third party products or services it shall not be deemed a license grant by ST for the use of such third party products or services, or any intellectual property contained therein or considered as a warranty covering the use in any manner whatsoever of such third party products or services or any intellectual property contained therein.

UNLESS OTHERWISE SET FORTH IN ST'S TERMS AND CONDITIONS OF SALE ST DISCLAIMS ANY EXPRESS OR IMPLIED WARRANTY WITH RESPECT TO THE USE AND/OR SALE OF ST PRODUCTS INCLUDING WITHOUT LIMITATION IMPLIED WARRANTIES OF MERCHANTABILITY, FITNESS FOR A PARTICULAR PURPOSE (AND THEIR EQUIVALENTS UNDER THE LAWS OF ANY JURISDICTION), OR INFRINGEMENT OF ANY PATENT, COPYRIGHT OR OTHER INTELLECTUAL PROPERTY RIGHT.

UNLESS EXPRESSLY APPROVED IN WRITING BY AN AUTHORIZED ST REPRESENTATIVE, ST PRODUCTS ARE NOT RECOMMENDED, AUTHORIZED OR WARRANTED FOR USE IN MILITARY, AIR CRAFT, SPACE, LIFE SAVING, OR LIFE SUSTAINING APPLICATIONS, NOR IN PRODUCTS OR SYSTEMS WHERE FAILURE OR MALFUNCTION MAY RESULT IN PERSONAL INJURY, DEATH, OR SEVERE PROPERTY OR ENVIRONMENTAL DAMAGE. ST PRODUCTS WHICH ARE NOT SPECIFIED AS "AUTOMOTIVE GRADE" MAY ONLY BE USED IN AUTOMOTIVE APPLICATIONS AT USER'S OWN RISK.

Resale of ST products with provisions different from the statements and/or technical features set forth in this document shall immediately void any warranty granted by ST for the ST product or service described herein and shall not create or extend in any manner whatsoever, any liability of ST.

ST and the ST logo are trademarks or registered trademarks of ST in various countries.

Information in this document supersedes and replaces all information previously supplied.

The ST logo is a registered trademark of STMicroelectronics. All other names are the property of their respective owners.

© 2010 STMicroelectronics - All rights reserved

STMicroelectronics group of companies

Australia - Belgium - Brazil - Canada - China - Czech Republic - Finland - France - Germany - Hong Kong - India - Israel - Italy - Japan - Malaysia - Malta - Morocco - Philippines - Singapore - Spain - Sweden - Switzerland - United Kingdom - United States of America

www.st.com

Looking for pricing, stock, or lifecycle information?

Click below to explore more details on WIN SOURCE:

 [View ST2G3236QTR on WIN SOURCE](#)

 [STMicroelectronics Information](#)

Optimize Your Supply Chain with WIN SOURCE Solutions

-  Global Sourcing Solution
-  Obsolete Management
-  Cost Control Management
-  Shortage Management
-  Alternative Solution
-  Excess Inventory Management