

DATA SHEET

74LV174

Hex D-type flip-flop with reset;
positive-edge trigger

Product specification
Supersedes data of 1997 Apr 07
IC24 Data Handbook

1998 May 20

Hex D-type flip-flop with reset; positive edge-trigger

74LV174

FEATURES

- Wide operating voltage: 1.0 to 5.5V
- Optimized for Low Voltage applications: 1.0 to 3.6V
- Accepts TTL input levels between $V_{CC} = 2.7V$ and $V_{CC} = 3.6V$
- Typical V_{OLP} (output ground bounce) $< 0.8V$ @ $V_{CC} = 3.3V$, $T_{amb} = 25^{\circ}C$
- Typical V_{OHV} (output V_{OH} undershoot) $> 2V$ @ $V_{CC} = 3.3V$, $T_{amb} = 25^{\circ}C$
- Output capability: standard
- I_{CC} category: MSI

DESCRIPTION

The 74LV174 is a low-voltage Si-gate CMOS device and is pin and function compatible with the 74HC/HCT174.

The 74LV174 has six edge-triggered D-type flip-flops with individual D inputs and Q outputs. The common clock (CP) and master reset (MR) inputs load and reset (clear) all flip-flops simultaneously.

The register is fully edge-triggered. The state of each D input, one set-up time prior to the LOW-to-HIGH clock transition, is transferred to the corresponding output of the flip-flop.

A LOW level on the MR input forces all outputs LOW, independently of clock or data inputs.

The device is useful for applications requiring true outputs only and clock and master reset inputs that are common to all storage elements.

QUICK REFERENCE DATA

GND = 0V; $T_{amb} = 25^{\circ}C$; $t_r = t_f \leq 2.5$ ns

SYMBOL	PARAMETER	CONDITIONS	TYPICAL	UNIT
t_{PHL}/t_{PLH}	Propagation delay CP to Q_n MR to Q_n	$C_L = 15pF$ $V_{CC} = 3.3V$	16 13	ns
f_{max}	Maximum clock frequency		77	MHz
C_I	Input capacitance		3.5	pF
C_{PD}	Power dissipation capacitance per flip-flop	$V_{CC} = 3.3V$ Notes 1 and 2	17	pF

NOTES:

1. C_{PD} is used to determine the dynamic power dissipation (P_D in μW)
 $P_D = C_{PD} \times V_{CC}^2 \times f_i + \sum (C_L \times V_{CC}^2 \times f_o)$ where:
 f_i = input frequency in MHz; C_L = output load capacitance in pF;
 f_o = output frequency in MHz; V_{CC} = supply voltage in V;
 $\sum (C_L \times V_{CC}^2 \times f_o)$ = sum of the outputs.
2. The condition is $V_I = GND$ to V_{CC}

ORDERING INFORMATION

PACKAGES	TEMPERATURE RANGE	OUTSIDE NORTH AMERICA	NORTH AMERICA	PKG. DWG. #
16-Pin Plastic DIL	-40°C to +125°C	74LV174 N	74LV174 N	SOT38-4
16-Pin Plastic SO	-40°C to +125°C	74LV174 D	74LV174 D	SOT109-1
16-Pin Plastic SSOP Type II	-40°C to +125°C	74LV174 DB	74LV174 DB	SOT338-1
16-Pin Plastic TSSOP	-40°C to +125°C	74LV174 PW	74LV174PW DH	SOT403-1

Hex D-type flip-flop with reset; positive edge-trigger

74LV174

PIN CONFIGURATION

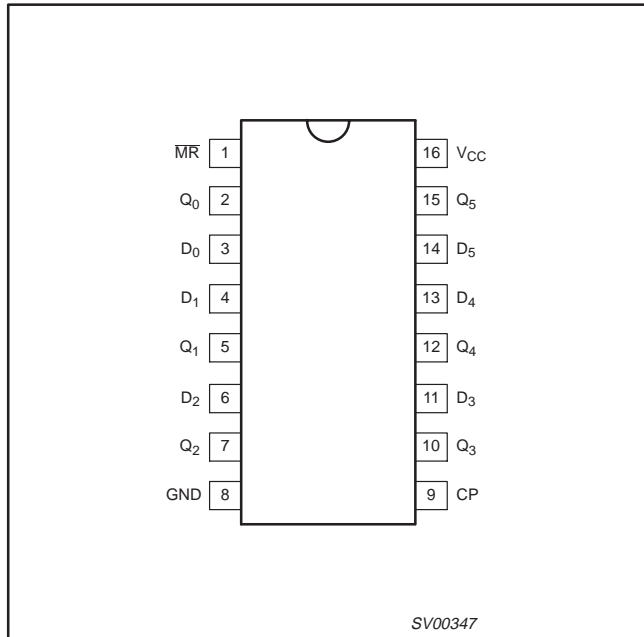

LOGIC SYMBOL

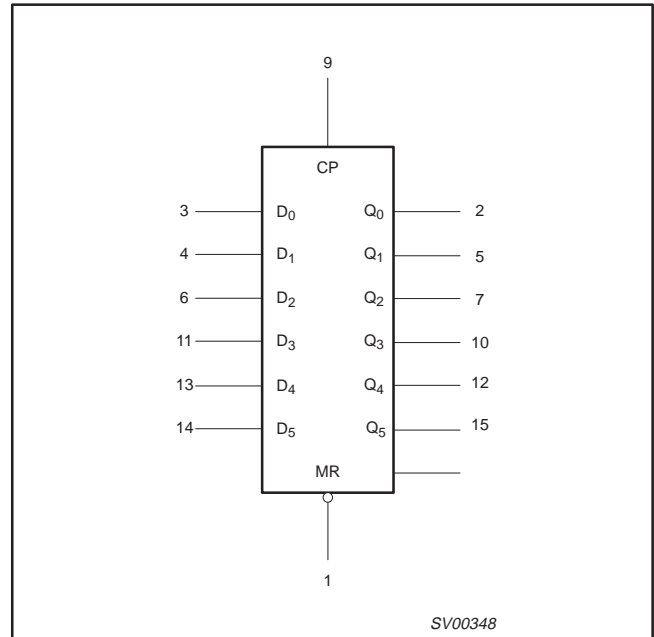

PIN DESCRIPTION

PIN NUMBER	SYMBOL	FUNCTION
1	MR	Asynchronous master reset (active LOW)
2, 5, 7, 10, 12, 15	Q ₀ to Q ₅	Flip-flop outputs
3, 4, 6, 11, 13, 14	D ₀ to D ₅	Data inputs
8	GND	Ground (0V)
9	CP	Clock input (LOW-to-HIGH, edge-triggered)
16	V _{CC}	Positive supply voltage

LOGIC SYMBOL (IEEE/IEC)

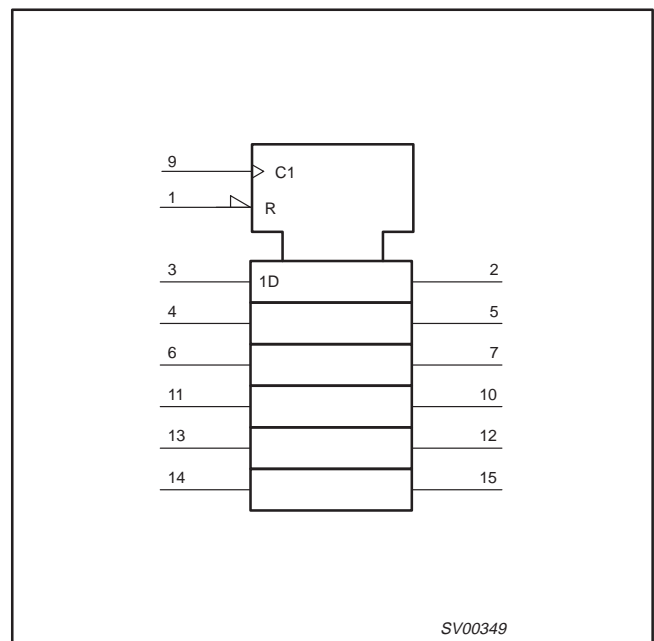

Hex D-type flip-flop with reset; positive edge-trigger

74LV174

FUNCTIONAL DIAGRAM

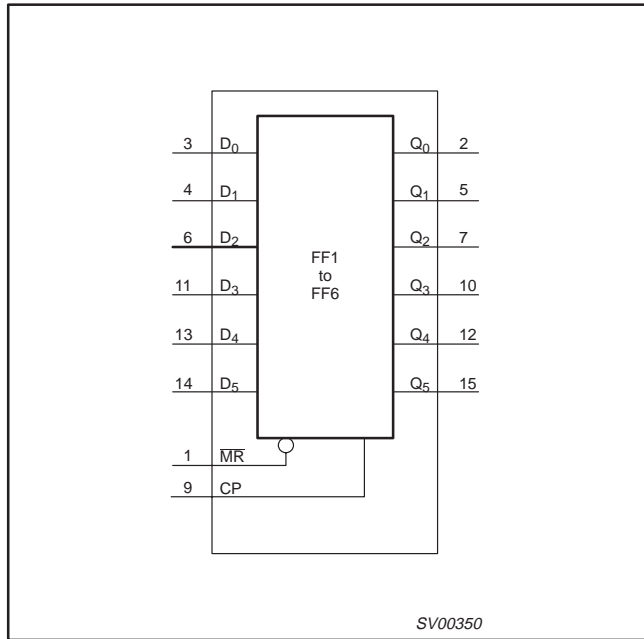

FUNCTION TABLE

OPERATING MODES	INPUTS			OUTPUTS
	MR	CP	D _n	Q ₀
Reset (clear)	L	X	X	L
Load '1'	H	↑	h	H
Load '0'	H	↑	l	L

- H = HIGH voltage level
- h = HIGH voltage level one set-up time prior to the LOW-to-HIGH CP transition
- L = LOW voltage level
- l = LOW voltage level one set-up time prior to the LOW-to-HIGH CP transition
- q = Lower case letter indicates the state of referenced input one set-up time prior to the LOW-to-HIGH CP transition
- ↑ = LOW-to-HIGH clock transition

RECOMMENDED OPERATING CONDITIONS

SYMBOL	PARAMETER	CONDITIONS	MIN	TYP.	MAX	UNIT
V _{CC}	DC supply voltage	See Note1	1.0	3.3	5.5	V
V _I	Input voltage		0	–	V _{CC}	V
V _O	Output voltage		0	–	V _{CC}	V
T _{amb}	Operating ambient temperature range in free air	See DC and AC characteristics	–40 –40		+85 +125	°C
t _r , t _f	Input rise and fall times	V _{CC} = 1.0V to 2.0V V _{CC} = 2.0V to 2.7V V _{CC} = 2.7V to 3.6V V _{CC} = 3.6V to 5.5V	– – – –	– – – –	500 200 100 50	ns/V

NOTES:

1. The LV is guaranteed to function down to V_{CC} = 1.0V (input levels GND or V_{CC}); DC characteristics are guaranteed from V_{CC} = 1.2V to V_{CC} = 5.5V.

Hex D-type flip-flop with reset; positive edge-trigger

74LV174

ABSOLUTE MAXIMUM RATINGS^{1, 2}

In accordance with the Absolute Maximum Rating System (IEC 134)

Voltages are referenced to GND (ground = 0V)

SYMBOL	PARAMETER	CONDITIONS	RATING	UNIT
V_{CC}	DC supply voltage		-0.5 to +7.0	V
$\pm I_{IK}$	DC input diode current	$V_I < -0.5$ or $V_I > V_{CC} + 0.5V$	20	mA
$\pm I_{OK}$	DC output diode current	$V_O < -0.5$ or $V_O > V_{CC} + 0.5V$	50	mA
$\pm I_O$	DC output source or sink current – standard outputs	$-0.5V < V_O < V_{CC} + 0.5V$	25	mA
$\pm I_{GND}$, $\pm I_{CC}$	DC V_{CC} or GND current for types with –standard outputs		50	mA
T_{stg}	Storage temperature range		-65 to +150	°C
P_{TOT}	Power dissipation per package –plastic DIL –plastic mini-pack (SO) –plastic shrink mini-pack (SSOP and TSSOP)	for temperature range: -40 to +125°C above +70°C derate linearly with 12mW/K above +70°C derate linearly with 8 mW/K above +60°C derate linearly with 5.5 mW/K	750 500 400	mW

NOTES:

- Stresses beyond those listed may cause permanent damage to the device. These are stress ratings only and functional operation of the device at these or any other conditions beyond those indicated under “recommended operating conditions” is not implied. Exposure to absolute-maximum-rated conditions for extended periods may affect device reliability.
- The input and output voltage ratings may be exceeded if the input and output current ratings are observed.

DC CHARACTERISTICS FOR THE LV FAMILY

Over recommended operating conditions voltages are referenced to GND (ground = 0V)

SYMBOL	PARAMETER	TEST CONDITIONS	LIMITS					UNIT
			-40°C to +85°C			-40°C to +125°C		
			MIN	TYP ¹	MAX	MIN	MAX	
V_{IH}	HIGH level Input voltage	$V_{CC} = 1.2V$	0.9			0.9		V
		$V_{CC} = 2.0V$	1.4			1.4		
		$V_{CC} = 2.7$ to $3.6V$	2.0			2.0		
		$V_{CC} = 4.5$ to $5.5V$	$0.7 \cdot V_{CC}$			$0.7 \cdot V_{CC}$		
V_{IL}	LOW level Input voltage	$V_{CC} = 1.2V$			0.3		0.3	V
		$V_{CC} = 2.0V$			0.6		0.6	
		$V_{CC} = 2.7$ to $3.6V$			0.8		0.8	
		$V_{CC} = 4.5$ to $5.5V$			$0.3 \cdot V_{CC}$		$0.3 \cdot V_{CC}$	
V_{OH}	HIGH level output voltage; all outputs	$V_{CC} = 1.2V$; $V_I = V_{IH}$ or V_{IL} ; $I_O = 100\mu A$		1.2				V
		$V_{CC} = 2.0V$; $V_I = V_{IH}$ or V_{IL} ; $I_O = 100\mu A$	1.8	2.0		1.8		
		$V_{CC} = 2.7V$; $V_I = V_{IH}$ or V_{IL} ; $I_O = 100\mu A$	2.5	2.7		2.5		
		$V_{CC} = 3.0V$; $V_I = V_{IH}$ or V_{IL} ; $I_O = 100\mu A$	2.8	3.0		2.8		
		$V_{CC} = 4.5V$; $V_I = V_{IH}$ or V_{IL} ; $I_O = 100\mu A$	4.3	4.5		4.3		
	HIGH level output voltage; STANDARD outputs	$V_{CC} = 3.0V$; $V_I = V_{IH}$ or V_{IL} ; $I_O = 6mA$	2.40	2.82		2.20		V
$V_{CC} = 4.5V$; $V_I = V_{IH}$ or V_{IL} ; $I_O = 12mA$		3.60	4.20		3.50			
V_{OL}	LOW level output voltage; all outputs	$V_{CC} = 1.2V$; $V_I = V_{IH}$ or V_{IL} ; $I_O = 100\mu A$		0				V
		$V_{CC} = 2.0V$; $V_I = V_{IH}$ or V_{IL} ; $I_O = 100\mu A$		0	0.2		0.2	
		$V_{CC} = 2.7V$; $V_I = V_{IH}$ or V_{IL} ; $I_O = 100\mu A$		0	0.2		0.2	
		$V_{CC} = 3.0V$; $V_I = V_{IH}$ or V_{IL} ; $I_O = 100\mu A$		0	0.2		0.2	
		$V_{CC} = 4.5V$; $V_I = V_{IH}$ or V_{IL} ; $I_O = 100\mu A$		0	0.2		0.2	
	LOW level output voltage; STANDARD outputs	$V_{CC} = 3.0V$; $V_I = V_{IH}$ or V_{IL} ; $I_O = 6mA$		0.25	0.40		0.50	V
$V_{CC} = 4.5V$; $V_I = V_{IH}$ or V_{IL} ; $I_O = 12mA$			0.35	0.55		0.65		

Hex D-type flip-flop with reset; positive edge-trigger

74LV174

DC CHARACTERISTICS FOR THE LV FAMILY (Continued)

Over recommended operating conditions voltages are referenced to GND (ground = 0V)

SYMBOL	PARAMETER	TEST CONDITIONS	LIMITS				UNIT	
			-40°C to +85°C		-40°C to +125°C			
I_I	Input leakage current	$V_{CC} = 5.5V$; $V_I = V_{CC}$ or GND			1.0		1.0	μA
I_{CC}	Quiescent supply current; MSI	$V_{CC} = 5.5V$; $V_I = V_{CC}$ or GND; $I_O = 0$			20.0		160	μA
ΔI_{CC}	Additional quiescent supply current per input	$V_{CC} = 2.7V$ to 3.6V; $V_I = V_{CC} - 0.6V$			500		850	μA

NOTE:1. All typical values are measured at $T_{amb} = 25^\circ C$.**AC CHARACTERISTICS**GND = 0V; $t_r = t_f = 2.5ns$; $C_L = 50pF$; $R_L = 1K\Omega$

SYMBOL	PARAMETER	WAVEFORM	CONDITION $V_{CC}(V)$	LIMITS -40 to +85 °C			LIMITS -40 to +125 °C		UNIT
				MIN	TYP ¹	MAX	MIN	MAX	
t_{PHL}/t_{PLH}	Propagation delay CP to Q_n	Figure 1	1.2	–	100	–	–	–	ns
			2.0	–	34	43	–	53	
			2.7	–	25	31	–	39	
			3.0 to 3.6	–	19 ²	25	–	31	
			4.5 to 5.5	–	13 ³	21	–	26	
t_{PHL}	Propagation delay \overline{MR} to Q_n	Figure 2	1.2	–	80	–	–	–	ns
			2.0	–	27	43	–	53	
			2.7	–	20	31	–	39	
			3.0 to 3.6	–	15 ²	25	–	31	
t_W	Clock pulse width HIGH to LOW	Figure 1	2.0	34	10	–	41	–	ns
			2.7	25	8	–	30	–	
			3.0 to 3.6	20	6 ²	–	24	–	
			4.5 to 5.5	13	4 ³	–	16	–	
t_W	Master reset pulse width LOW	Figure 2	2.0	34	9	–	41	–	ns
			2.7	25	6	–	30	–	
			3.0 to 3.6	20	5	–	24	–	
			4.5 to 5.5	13	4 ²	–	16	–	
t_{rem}	Removal time \overline{MR} to CP	Figure 2	1.2	–	–20	–	–	–	ns
			2.0	5	–7	–	5	–	
			2.7	5	–5	–	5	–	
			3.0 to 3.6	5	–4 ²	–	5	–	
			4.5 to 5.5	5	–3 ³	–	5	–	
t_{su}	Set-up time D_n to CP	Figure 3	1.2	–	10	–	–	–	ns
			2.0	22	4	–	26	–	
			2.7	16	3	–	19	–	
			3.0 to 3.6	13	2 ²	–	15	–	
			4.5 to 5.5	9	1 ³	–	10	–	

Hex D-type flip-flop with reset; positive edge-trigger

74LV174

AC CHARACTERISTICS (Continued)

GND = 0V; $t_r = t_f = 2.5\text{ns}$; $C_L = 50\text{pF}$; $R_L = 1\text{K}\Omega$

SYMBOL	PARAMETER	WAVEFORM	CONDITION	LIMITS -40 to +85 °C			LIMITS -40 to +125 °C		UNIT
				V _{CC} (V)	MIN	TYP ¹	MAX	MIN	
t _h	Hold time D _n to CP	Figure 3	1.2	-	-10	-	-	-	ns
			2.0	5	-4	-	5	-	
			2.7	5	-2	-	5	-	
			3.0 to 3.6	5	-2 ²	-	5	-	
			4.5 to 5.5	5	-1 ³	-	5	-	
f _{max}	Maximum clock pulse frequency	Figure 1	2.0	14	40	-	12	-	MHz
			2.7	19	58	-	16	-	
			3.0 to 3.6	24	70 ²	-	20	-	
			4.5 to 5.5	36	100 ³	-	30	-	

NOTES:

1. Unless otherwise stated, all typical values are at T_{amb} = 25°C.
2. Typical value measured at V_{CC} = 3.3V.
3. Typical value measured at V_{CC} = 5.0V.

AC WAVEFORMS

V_M = 1.5V at V_{CC} ≥ 2.7V ≤ 3.6V

V_M = 0.5V * V_{CC} at V_{CC} < 2.7V and ≥ 4.5V

V_{OL} and V_{OH} are the typical output voltage drop that occur with the output load.

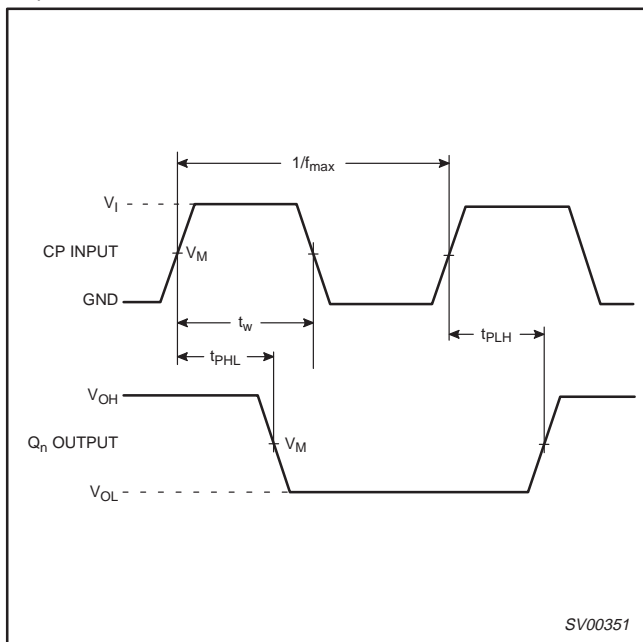

Figure 1. The clock (CP) to output (Q_n) propagation delays, the clock pulse width, and the maximum clock pulse frequency.

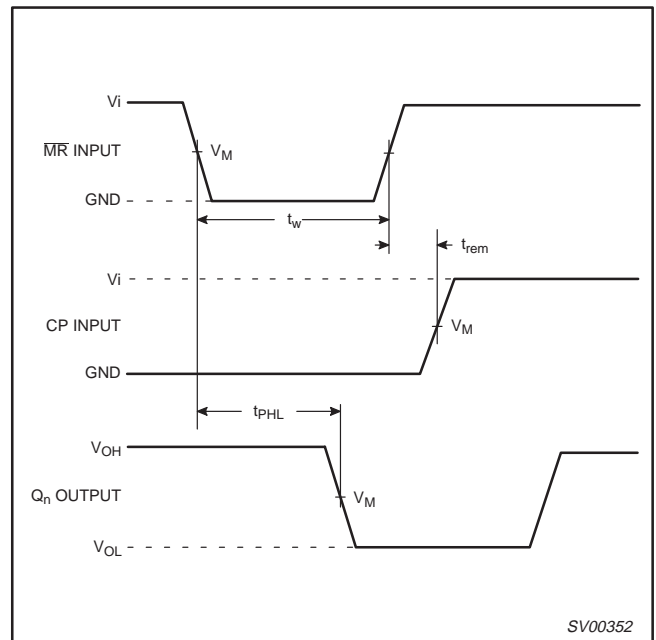

Figure 2. The master reset (\overline{MR}) pulse width, the master reset to output (Q_n) propagation delay and the master reset to clock removal time.

Hex D-type flip-flop with reset; positive edge-trigger

74LV174

AC WAVEFORMS (Continued)

$V_M = 1.5V$ at $V_{CC} \geq 2.7V \leq 3.6V$

$V_M = 0.5V * V_{CC}$ at $V_{CC} < 2.7V$ and $\geq 4.5V$

V_{OL} and V_{OH} are the typical output voltage drop that occur with the output load.

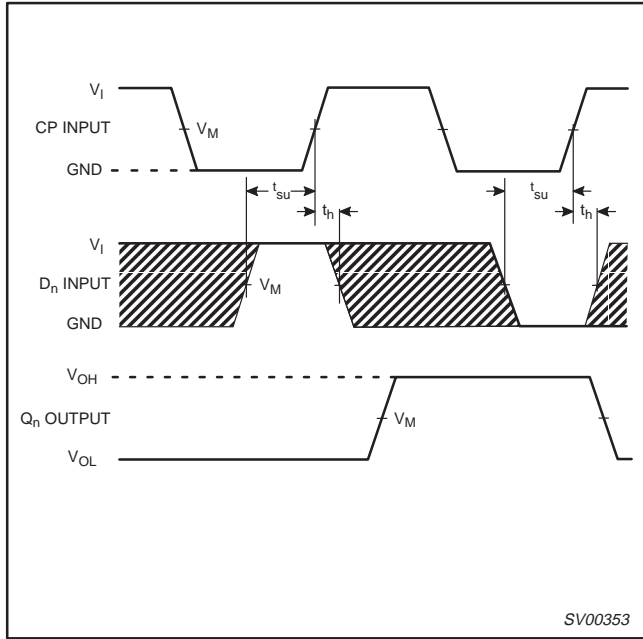

Figure 3. Data set-up and hold times for the data input (D_n).

NOTE:

The shaded areas indicate when the input is permitted to change for predictable output performance.

TEST CIRCUIT

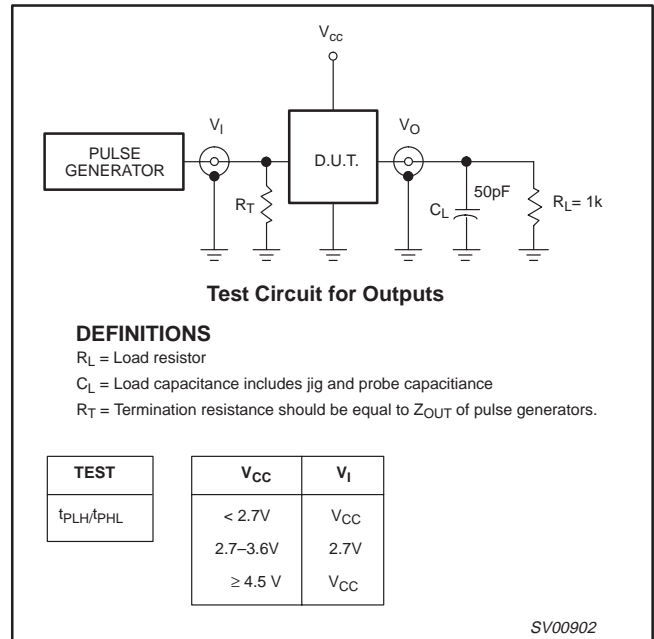

Figure 4. Load circuitry for switching times

Hex D-type flip-flop with reset; positive edge-trigger

74LV174

DIP16: plastic dual in-line package; 16 leads (300 mil)

SOT38-4

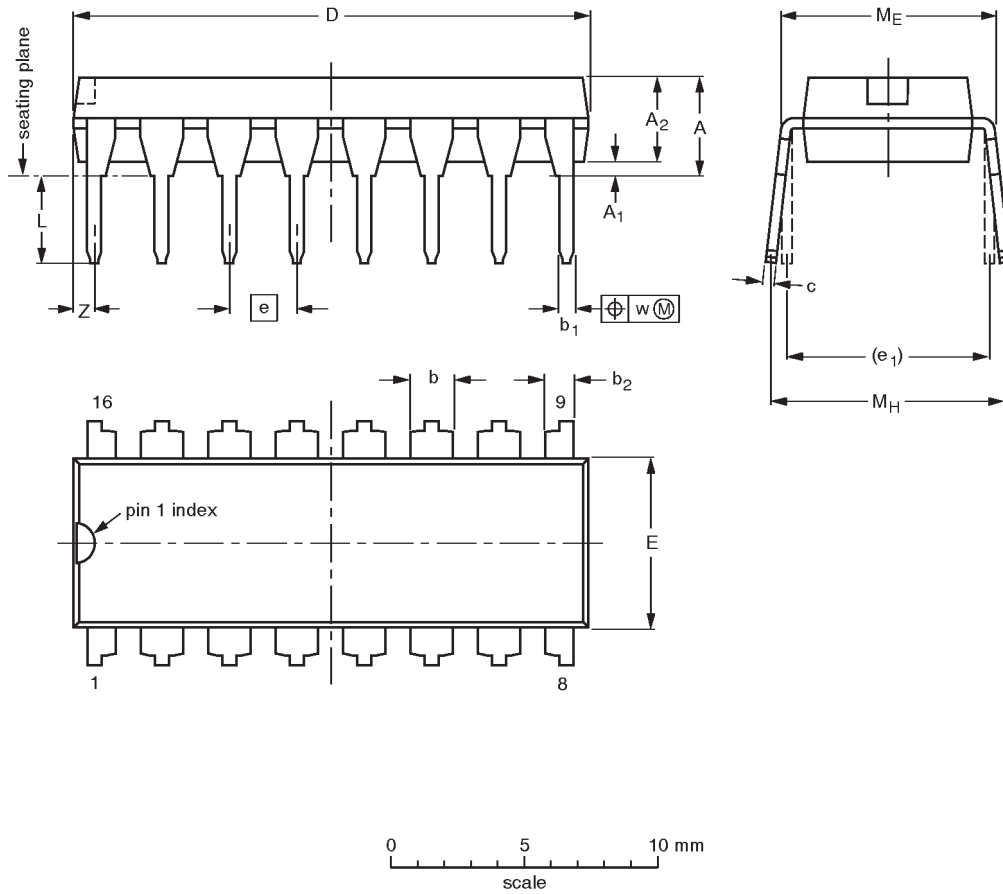

DIMENSIONS (inch dimensions are derived from the original mm dimensions)

UNIT	A max.	A ₁ min.	A ₂ max.	b	b ₁	b ₂	c	D ⁽¹⁾	E ⁽¹⁾	e	e ₁	L	M _E	M _H	w	Z ⁽¹⁾ max.
mm	4.2	0.51	3.2	1.73 1.30	0.53 0.38	1.25 0.85	0.36 0.23	19.50 18.55	6.48 6.20	2.54	7.62	3.60 3.05	8.25 7.80	10.0 8.3	0.254	0.76
inches	0.17	0.020	0.13	0.068 0.051	0.021 0.015	0.049 0.033	0.014 0.009	0.77 0.73	0.26 0.24	0.10	0.30	0.14 0.12	0.32 0.31	0.39 0.33	0.01	0.030

Note

1. Plastic or metal protrusions of 0.25 mm maximum per side are not included.

OUTLINE VERSION	REFERENCES				EUROPEAN PROJECTION	ISSUE DATE
	IEC	JEDEC	EIAJ			
SOT38-4						-92-11-17 95-01-14

Hex D-type flip-flop with reset; positive edge-trigger

74LV174

SO16: plastic small outline package; 16 leads; body width 3.9 mm

SOT109-1

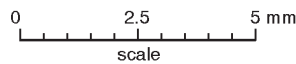
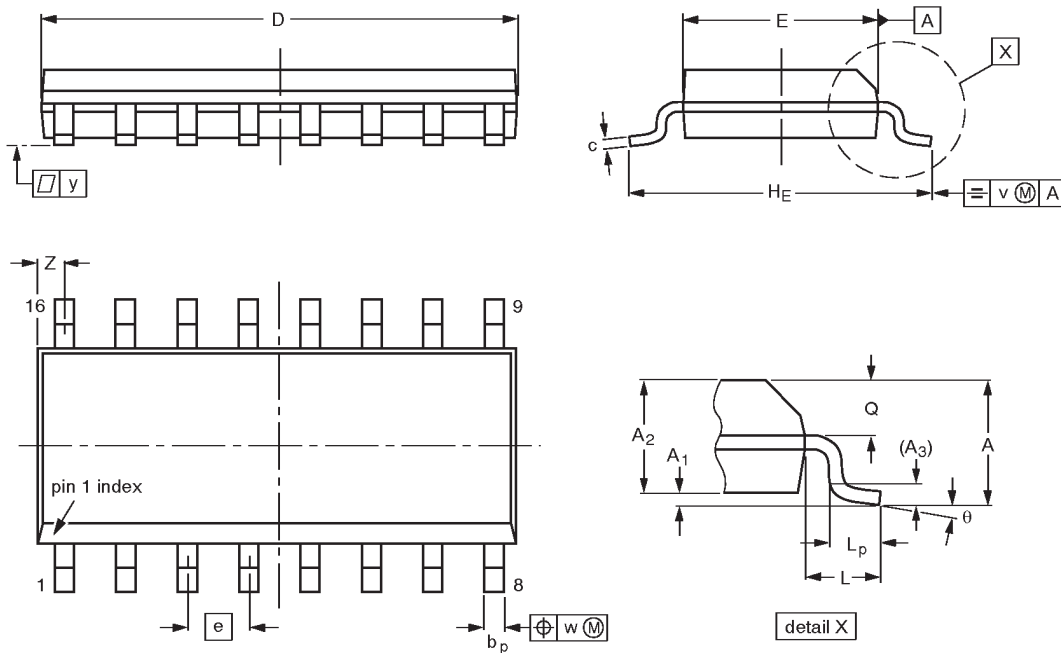

DIMENSIONS (inch dimensions are derived from the original mm dimensions)

UNIT	A max.	A ₁	A ₂	A ₃	b _p	c	D ⁽¹⁾	E ⁽¹⁾	e	H _E	L	L _p	Q	v	w	y	z ⁽¹⁾	θ
mm	1.75	0.25 0.10	1.45 1.25	0.25	0.49 0.36	0.25 0.19	10.0 9.8	4.0 3.8	1.27	6.2 5.8	1.05	1.0 0.4	0.7 0.6	0.25	0.25	0.1	0.7 0.3	8° 0°
inches	0.069	0.0098 0.0039	0.057 0.049	0.01	0.019 0.014	0.0098 0.0075	0.39 0.38	0.16 0.15	0.050	0.24 0.23	0.041	0.039 0.016	0.028 0.020	0.01	0.01	0.004	0.028 0.012	

Note

1. Plastic or metal protrusions of 0.15 mm maximum per side are not included.

OUTLINE VERSION	REFERENCES				EUROPEAN PROJECTION	ISSUE DATE
	IEC	JEDEC	EIAJ			
SOT109-1	076E07S	MS-012AC				91-08-13 95-01-23

Hex D-type flip-flop with reset; positive edge-trigger

74LV174

SSOP16: plastic shrink small outline package; 16 leads; body width 5.3 mm

SOT338-1

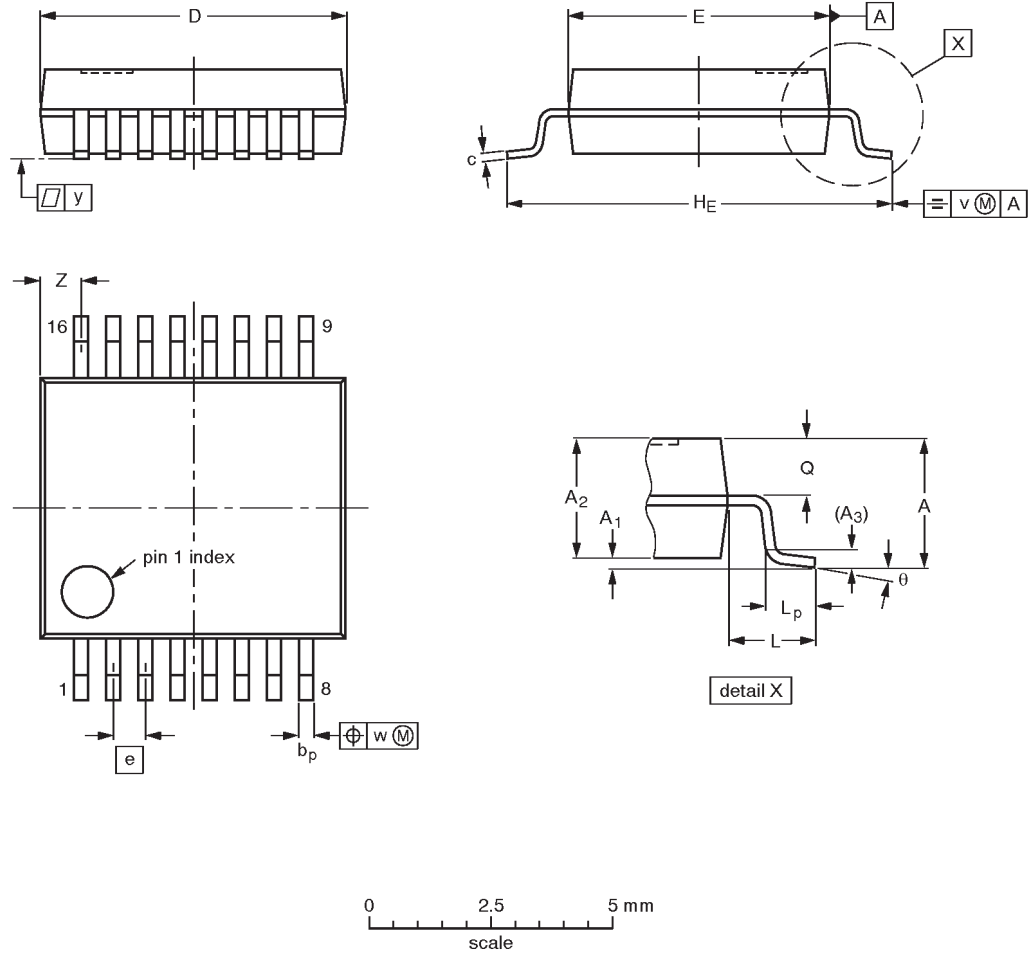

DIMENSIONS (mm are the original dimensions)

UNIT	A max.	A ₁	A ₂	A ₃	b _p	c	D ⁽¹⁾	E ⁽¹⁾	e	H _E	L	L _p	Q	v	w	y	Z ⁽¹⁾	θ
mm	2.0	0.21 0.05	1.80 1.65	0.25	0.38 0.25	0.20 0.09	6.4 6.0	5.4 5.2	0.65	7.9 7.6	1.25	1.03 0.63	0.9 0.7	0.2	0.13	0.1	1.00 0.55	8° 0°

Note

1. Plastic or metal protrusions of 0.25 mm maximum per side are not included.

OUTLINE VERSION	REFERENCES				EUROPEAN PROJECTION	ISSUE DATE
	IEC	JEDEC	EIAJ			
SOT338-1		MO-150AC				94-01-14- 95-02-04

Hex D-type flip-flop with reset; positive edge-trigger

74LV174

TSSOP16: plastic thin shrink small outline package; 16 leads; body width 4.4 mm

SOT403-1

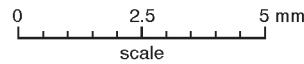
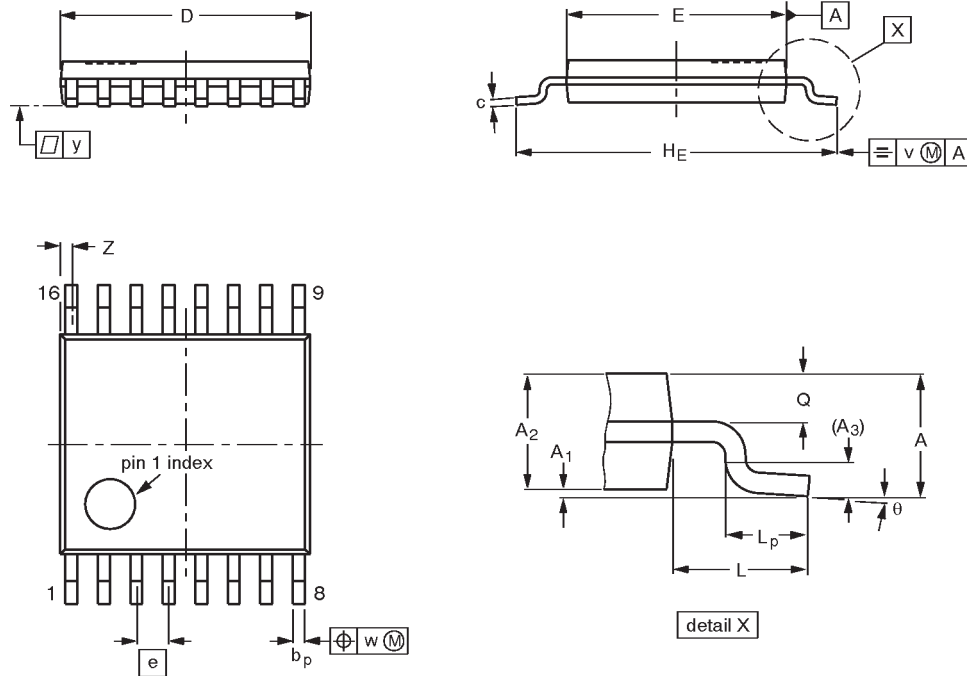

DIMENSIONS (mm are the original dimensions)

UNIT	A max.	A ₁	A ₂	A ₃	b _p	c	D ⁽¹⁾	E ⁽²⁾	e	H _E	L	L _p	Q	v	w	y	Z ⁽¹⁾	θ
mm	1.10	0.15 0.05	0.95 0.80	0.25	0.30 0.19	0.2 0.1	5.1 4.9	4.5 4.3	0.65	6.6 6.2	1.0	0.75 0.50	0.4 0.3	0.2	0.13	0.1	0.40 0.06	8° 0°

Notes

1. Plastic or metal protrusions of 0.15 mm maximum per side are not included.
2. Plastic interlead protrusions of 0.25 mm maximum per side are not included.

OUTLINE VERSION	REFERENCES				EUROPEAN PROJECTION	ISSUE DATE
	IEC	JEDEC	EIAJ			
SOT403-1		MO-153				94-07-12 95-04-04

Hex D-type flip-flop with reset; positive edge-trigger

74LV174

NOTES

Hex D-type flip-flop with reset; positive edge-trigger

74LV174

DEFINITIONS

Data Sheet Identification	Product Status	Definition
<i>Objective Specification</i>	Formative or in Design	This data sheet contains the design target or goal specifications for product development. Specifications may change in any manner without notice.
<i>Preliminary Specification</i>	Preproduction Product	This data sheet contains preliminary data, and supplementary data will be published at a later date. Philips Semiconductors reserves the right to make changes at any time without notice in order to improve design and supply the best possible product.
<i>Product Specification</i>	Full Production	This data sheet contains Final Specifications. Philips Semiconductors reserves the right to make changes at any time without notice, in order to improve design and supply the best possible product.

Philips Semiconductors and Philips Electronics North America Corporation reserve the right to make changes, without notice, in the products, including circuits, standard cells, and/or software, described or contained herein in order to improve design and/or performance. Philips Semiconductors assumes no responsibility or liability for the use of any of these products, conveys no license or title under any patent, copyright, or mask work right to these products, and makes no representations or warranties that these products are free from patent, copyright, or mask work right infringement, unless otherwise specified. Applications that are described herein for any of these products are for illustrative purposes only. Philips Semiconductors makes no representation or warranty that such applications will be suitable for the specified use without further testing or modification.

LIFE SUPPORT APPLICATIONS

Philips Semiconductors and Philips Electronics North America Corporation Products are not designed for use in life support appliances, devices, or systems where malfunction of a Philips Semiconductors and Philips Electronics North America Corporation Product can reasonably be expected to result in a personal injury. Philips Semiconductors and Philips Electronics North America Corporation customers using or selling Philips Semiconductors and Philips Electronics North America Corporation Products for use in such applications do so at their own risk and agree to fully indemnify Philips Semiconductors and Philips Electronics North America Corporation for any damages resulting from such improper use or sale.

Philips Semiconductors
811 East Arques Avenue
P.O. Box 3409
Sunnyvale, California 94088-3409
Telephone 800-234-7381

© Copyright Philips Electronics North America Corporation 1998
 All rights reserved. Printed in U.S.A.

print code

Date of release: 05-96

Document order number:

9397-750-04433

Let's make things better.

Looking for pricing, stock, or lifecycle information?

Click below to explore more details on WIN SOURCE:

 [View 74LV174PW,118 on WIN SOURCE](#)

 [NXP / Nexperia Information](#)

Optimize Your Supply Chain with WIN SOURCE Solutions

-  Global Sourcing Solution
-  Obsolete Management
-  Cost Control Management
-  Shortage Management
-  Alternative Solution
-  Excess Inventory Management