



**THE DATASHEET OF
ST16C32245TBR**



14-bit dual supply bus transceiver level translator A side series resistor, 2-bit I²C lines

Features

- High speed: $t_{PD} = 4.4 \text{ ns (max)}$ at $T_A = 85 \text{ }^\circ\text{C}$
 $V_{CCA} = 3.0 \text{ V}$ and $V_{CCB} = 2.3 \text{ V}$
- Low power dissipation:
 $I_{CCA} = I_{CCB} = 20 \text{ } \mu\text{A(max)}$ at $T_A = 85 \text{ }^\circ\text{C}$
- Symmetrical output impedance:
 $|I_{OHA}| = |I_{OLA}| = 8 \text{ mA min}$
($V_{CCA} = 3.0 \text{ V}$; $V_{CCB} = 1.65 \text{ V}$ or 2.3 V)
 $|I_{OHB}| = |I_{OLB}| = 6 \text{ mA min}$
($V_{CCB} = 1.65 \text{ V}$ $V_{CCA} = 3.0 \text{ V}$;)
- Balanced propagation delays: $t_{PLH} \approx t_{PHL}$
- Power down protection on inputs and outputs
- $26 \text{ } \Omega$ series resistor on A side outputs
- Operating voltage range:
 $V_{CCA} \text{ (opr)} = 2.3 \text{ V to } 3.6 \text{ V}$
 $V_{CCB} \text{ (opr)} = 1.65 \text{ V to } 2.7 \text{ V}$
- Fast I²C lines 1.8 V/2.8 V level translator:
400 KHz guaranteed data rate at $C_L = 15 \text{ pF}$
- Bus hold provided on data input both side
- Latch-up performance exceeds 500mA (JESD 17)
- ESD performance:
HBM > 2000 V (MIL STD 883 method 3015);
MM > 200 V

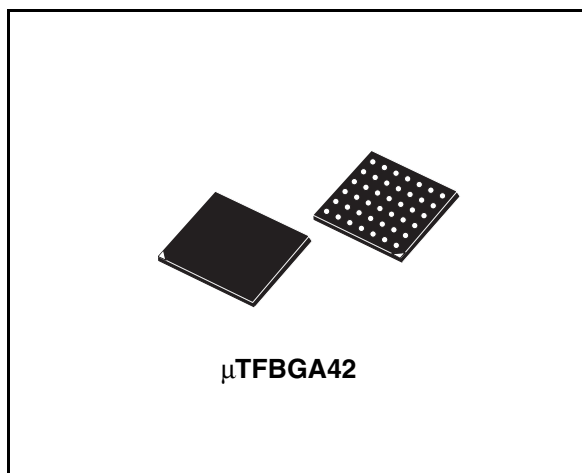

Description

The ST16C32245 is a dual supply low voltage CMOS 14-bit bus transceiver fabricated with sub-micron silicon gate and five-layer metal wiring C²MOS technology. Designed for use as an interface between a 3.3 V bus and a 2.5 V or 1.8 V bus in a mixed 3.3 V/1.8 V, 3.3 V/2.5 V and 2.5 V/1.8 V supply systems, it achieves high speed operation while maintaining the CMOS low power dissipation and it includes 2-bit I²C level translation. This IC is intended for two-way asynchronous communication between data buses and the direction of data transmission is determined by nDIR inputs. The enable inputs \overline{nG} can be used to disable the device so that the buses are effectively isolated. The A-port interfaces with the 3 V bus, the B-port with the 2.5 V and 1.8 V bus. All inputs are equipped with protection circuits against static discharge, giving them 2 KV ESD immunity and transient excess voltage. All floating bus terminals during high Z state do not need external pull-up or pull-down resistor.

Table 1. Device summary

Order code	Package	Packaging
ST16C32245TBR	μTFBGA42	Tape and reel

Contents

1	General description	3
2	Pin settings	5
2.1	Pin connection	5
2.2	I2C bus function	6
3	Maximum rating	7
3.1	Recommended operating conditions	8
4	Electrical characteristics	9
5	Test circuit	16
6	Waveforms	17
7	Package mechanical data	19
8	Revision history	22

1 General description

Figure 1. Logic diagram

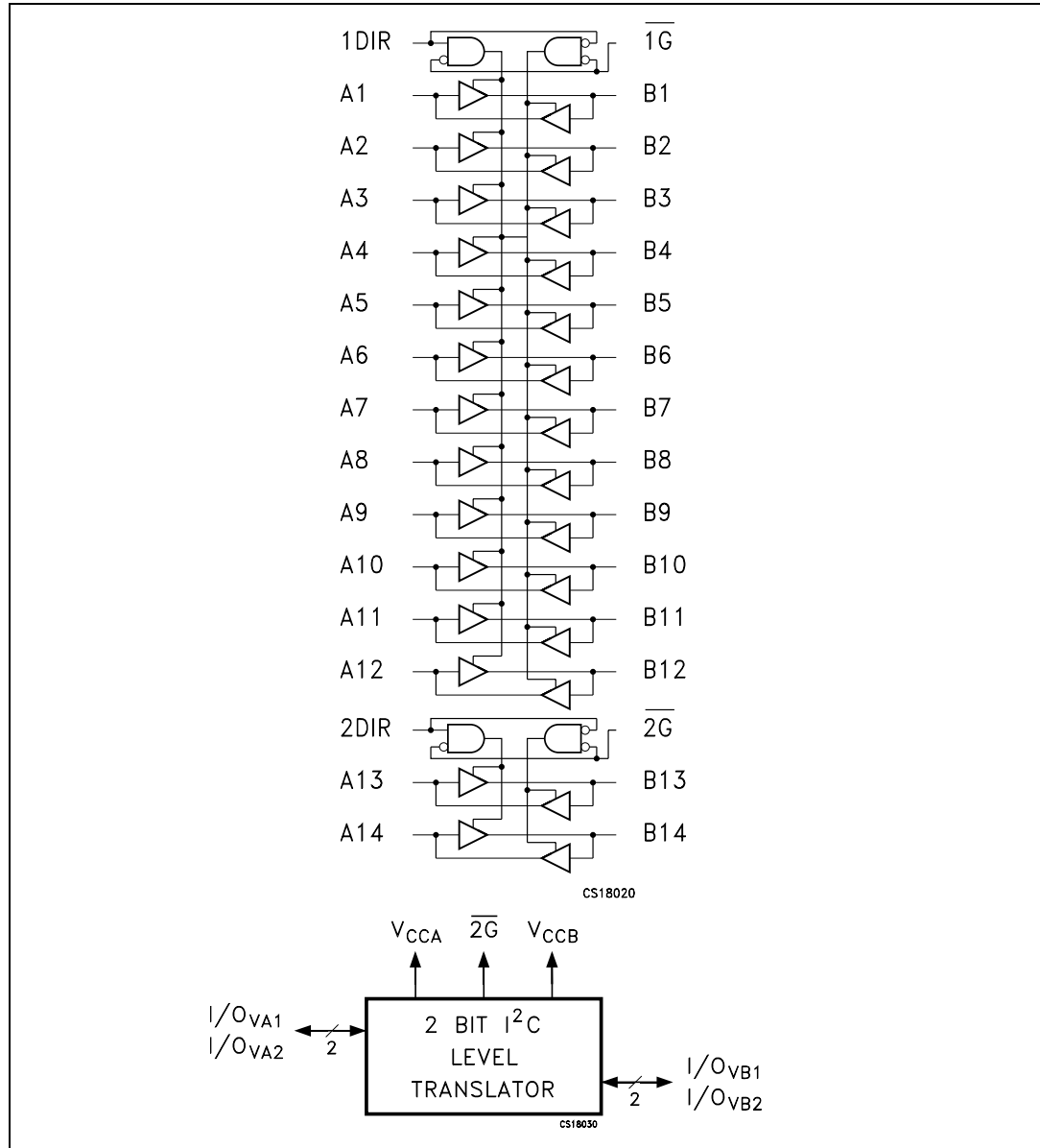
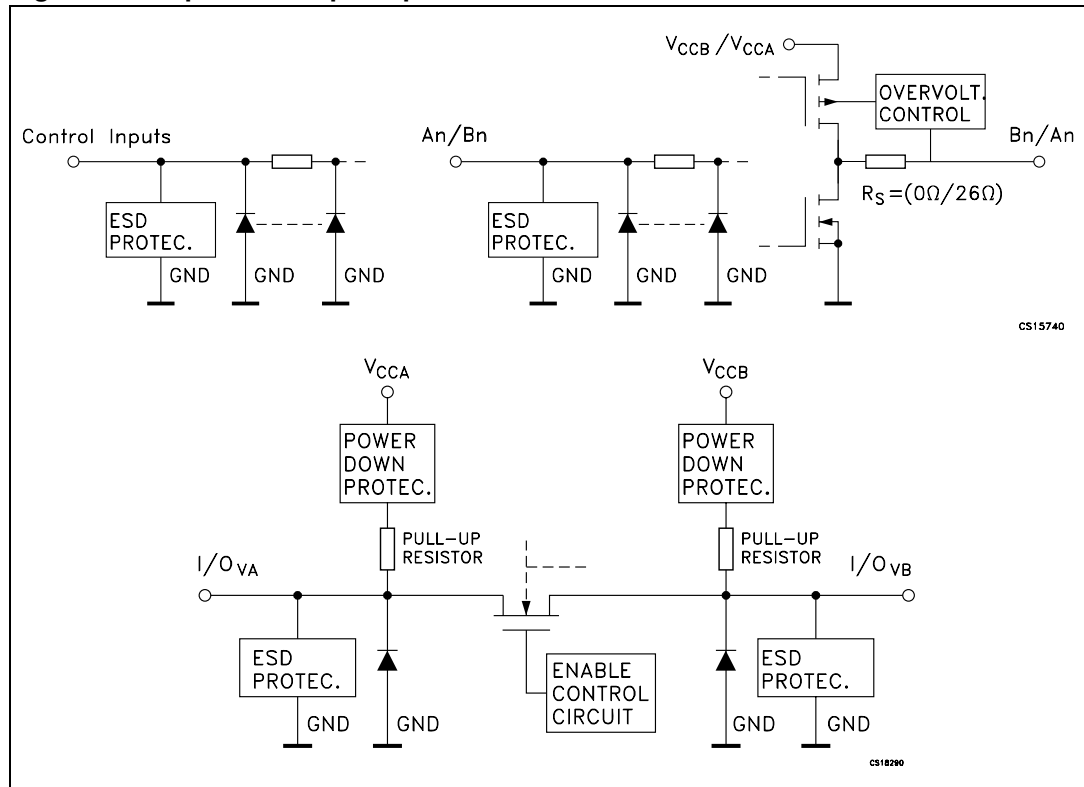

Figure 2. Input and output equivalent circuit



2 Pin settings

2.1 Pin connection

Figure 3. Pin connection (top through view)

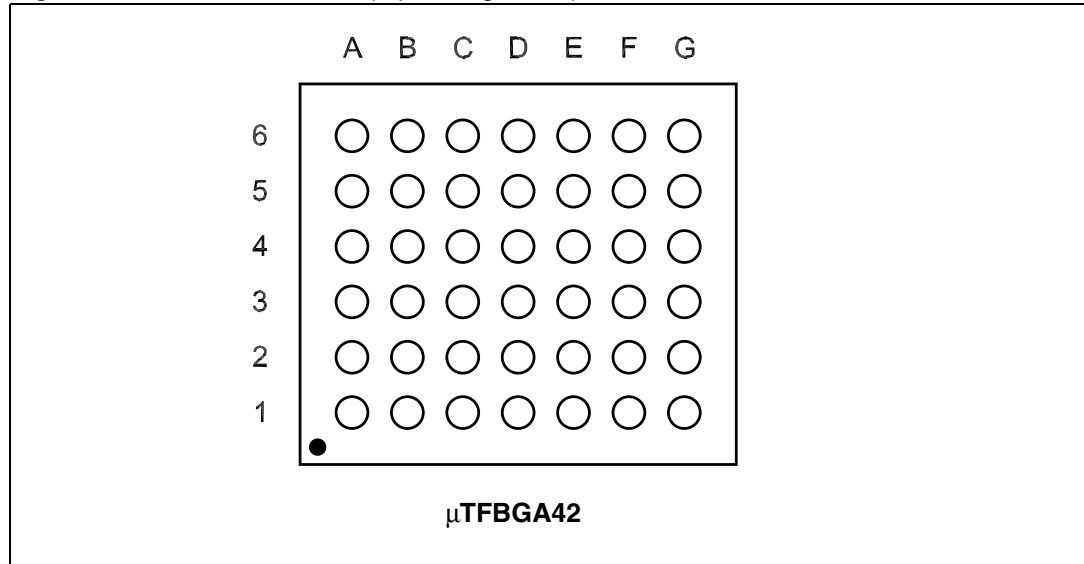

Table 2. Pin description

Pin number	Symbol	Name and function
B3	1DIR	Directional controls
F3	2DIR	Directional controls
A4, A5, A6, B5, B6, C5, C6, D5	A1, A2, A3, A4, A5, A6, A7, A8	Data Inputs/outputs
D6, E5, E6, F5, F6, G6	A9, A10, A11, A12, A13, A14	Data Inputs/outputs
A3, A2, A1, B2, B1, C2, C1, D2	B1, B2, B3, B4, B5, B6, B7, B8	Data Inputs/outputs
D1, E2, E1, F2, F1, G1	B9, B10, B11, B12, B13, B14	Data Inputs/outputs
F4	$\overline{2G}$	Output enable inputs
B4	$\overline{1G}$	Output enable inputs
C3, C4, E3, E4	GND	Ground (0V)
-	NC	No connected
D4	V _{CCA}	Positive supply voltage
D3	V _{CCB}	Positive supply voltage
G5, G4	I/O _{VA1} , I/O _{VA2}	I ² C Line (V _{CCA} referred)
G2, G3	I/O _{VB1} , I/O _{VB2}	I ² C Line (V _{CCB} referred)

Table 3. Truth table

Inputs		Function		Output
\overline{G}	DIR	A bus	B bus	
L	L	Output	Input	A = B
L	H	Input	Output	B = A
H	X	Z	Z	Z

Note: X = don't care; Z = high Impedance

2.2 I²C bus function

Table 4. I²C Bus function table

$\overline{2G}$	$\overline{1G}$, 1DIR, 2DIR	I/O input		Function
		I/O _{VA}	I/O _{VB}	
H	X	Z	Z	I ² C disabled
L	X	L	L	I ² C comm.
L	X	V _{CCA}	V _{CCB}	I ² C comm.
L	X	Open	V _{CCB}	I ² C comm.
L	X	V _{CCA}	Open	I ² C comm.

Note: Open: If I/O_{VA} is not driven then the I/O_{VB} goes in high level V_{CCB} by embedded 10 kΩ pull-up resistor. If I/O_{VB} is not driven then the I/O_{VA} will go in high level V_{CCB} by embedded 10 kΩ pull-up resistor.

3 Maximum rating

Stressing the device above the rating listed in the “Absolute Maximum Ratings” table may cause permanent damage to the device. These are stress ratings only and operation of the device at these or any other conditions above those indicated in the Operating sections of this specification is not implied. Exposure to Absolute Maximum Rating conditions for extended periods may affect device reliability.

Table 5. Absolute maximum ratings

Symbol	Parameter	Value	Unit
V_{CCA}	Supply voltage	-0.5 to +4.6	V
V_{CCB}	Supply voltage	-0.5 to +4.6	V
V_I	DC input voltage	-0.5 to +4.6	V
$V_{I/OA}$	DC I/O voltage (Output disabled)	-0.5 to +4.6	V
$V_{I/OB}$	DC I/O voltage (Output disabled)	-0.5 to +4.6	V
$V_{I/OA}$	DC I/O voltage	-0.5 to $V_{CCA} + 0.5$	V
$V_{I/OB}$	DC I/O voltage	-0.5 to $V_{CCB} + 0.5$	V
$V_{I/OVA}$	Level input voltage (I/O_{VA})	-0.5 to $V_{CCA} + 0.5$	V
$V_{I/OVB}$	Level input voltage (I/O_{VB})	-0.5 to $V_{CCB} + 0.5$	V
I_{IK}	DC input diode current	-20	mA
I_{OK}	DC output diode current	-50	mA
I_{OA}	DC output current	± 50	mA
I_{OB}	DC output current	± 50	mA
I_{CCA}	DC V_{CC} or ground current	± 100	mA
I_{CCB}	DC V_{CC} or ground current	± 100	mA
P_d	Power dissipation	400	mW
T_{stg}	Storage temperature	-65 to +150	$^{\circ}\text{C}$
T_L	Lead temperature (10 sec)	260	$^{\circ}\text{C}$

3.1 Recommended operating conditions

Table 6. Recommended operating conditions

Symbol	Parameter	Value	Unit
V_{CCA}	Supply voltage	2.3 to 3.6	V
V_{CCB}	Supply voltage	1.65 to 2.7	V
V_I	Input voltage (Dir, \overline{G})	0 to V_{CCB}	V
$V_{I/OA}$	I/O voltage	0 to V_{CCA}	V
$V_{I/OB}$	I/O voltage	0 to V_{CCB}	V
$V_{I/OVA}$	Level input voltage (I/O_{VA})	0 to V_{CCA}	V
$V_{I/OVB}$	Level input voltage (I/O_{VB})	0 to V_{CCB}	V
T_{op}	Operating temperature	-40 to +85	°C
dt/dv	Input rise and fall time	0 to 10	ns/V

4 Electrical characteristics

Table 7. DC specification for V_{CCA}

Symbol	Parameter	Test condition			Value				Unit
		V_{CCB} (V)	V_{CCA} (V)		$T_A = 25\text{ }^\circ\text{C}$		$-40\text{ to }85\text{ }^\circ\text{C}$		
					Min	Max	Min	Max	
V_{IHA}	High level input voltage (An) ⁽¹⁾	1.8	2.5		1.6		1.6		V
		1.8	3.3		2.0		2.0		
		2.5	3.3		2.0		2.0		
V_{ILA}	Low level input voltage (An) ⁽¹⁾	1.8	2.5			0.7		0.7	V
		1.8	3.3			0.8		0.8	
		2.5	3.3			0.8		0.8	
V_{OHA}	High level output voltage	2.3	3.0	$I_O = -100\text{ }\mu\text{A}$	2.8		2.8		V
		2.3	3.0	$I_O = -8\text{ mA}$	2.4		2.4		
		1.65	3.0	$I_O = -8\text{ mA}$	2.4		2.4		
		1.65	2.3	$I_O = -6\text{ mA}$	1.8		1.8		
V_{OLA}	Low level output voltage	2.3	3.0	$I_O = 100\text{ }\mu\text{A}$		0.2		0.2	V
		2.3	3.0	$I_O = 8\text{ mA}$		0.55		0.55	
		1.65	3.0	$I_O = 8\text{ mA}$		0.55		0.55	
		1.65	2.3	$I_O = 6\text{ mA}$		0.40		0.40	
I_{IA}	Input leakage current	2.7	3.6	$V_I = V_{CC}$ or GND		± 0.5		± 5	μA
$I_{IA(HOLD)}$	Input hold current	1.65	2.3	$V_I = 0.7\text{ V}$	45		45		μA
		1.65	2.3	$V_I = 1.6\text{ V}$	-45		-45		
		1.65	3.0	$V_I = 0.8\text{ V}$	75		75		
		1.65	3.0	$V_I = 2.0\text{ V}$	-75		-75		
		2.3	3.0	$V_I = 0.8\text{ V}$	75		75		
		2.3	3.0	$V_I = 2.0\text{ V}$	-75		-75		
		2.7	3.6	$V_I = 0\text{ to }3.6\text{ V}$				± 500	
I_{OZA}	High impedance output leakage current	2.7	3.6	$V_{IA} = \text{GND or }3.6\text{ V}$ $V_{IB} = V_{IHB}\text{ or }V_{ILB}$ $\bar{G} = V_{CCB}$		± 1.0		± 10	μA
I_{OFF}	Power off leakage current	0	0	$V_{IA} = \text{GND to }3.6\text{ V}$ $V_{IB} = \text{GND to }3.6\text{ V}$ $\bar{G}, \text{Dir} = \text{GND to }3.6\text{ V}$		± 1.0		± 10	μA

Table 7. DC specification for V_{CCA} (continued)

Symbol	Parameter	Test condition			Value				Unit
		V _{CCB} (V)	V _{CCA} (V)		T _A = 25 °C		-40 to 85°C		
					Min	Max	Min	Max	
I _{OFFI2C}	Power Off I ² C line leakage current	1.65 to 2.7	0	I/O _{VA1,2} = GND or V _{CCA} ; I/O _{VB1,2} = GND or V _{CCB} ; 2 \bar{G} = V _{CCB}		1.0		5	μA
I _{CCIA}	Quiescent supply current	1.95	3.6	V _{IA} = V _{CCA} or GND		2		20	μA
		1.95	2.7	V _{IB} = V _{CCB} or GND					
		2.7	3.6	I/O _{VA1,2} = V _{CCA} or Open; Dir, \bar{G} = GND or V _{CCB}					
ΔI _{CCtA}	Maximum quiescent supply current / Input (An)	2.7	3.6	V _{IA} = V _{CCA} - 0.6V V _{IB} = V _{CCB} or GND				0.75	mA
		1.95	3.6						
		1.95	2.7						

1. V_{CC} range = 3.3±0.3; 2.5±0.2V and 2.8±0.1V; 1.8±0.15V

Table 8. DC specification for V_{CCB}

Symbol	Parameter	Test condition			Value				Unit
		V _{CCB} (V)	V _{CCA} (V)		T _A = 25 °C		-40 to 85°C		
					Min	Max	Min	Max	
V _{IHB}	High level input voltage (Bn, Dir, \bar{G}) ⁽¹⁾	1.8	2.5		0.65V _{CCB}		0.65V _{CCB}		V
		1.8	3.3		0.65V _{CCB}		0.65V _{CCB}		
		2.5	3.3		1.6		1.6		
V _{ILB}	Low level input voltage (Bn, Dir, \bar{G}) ⁽¹⁾	1.8	2.5			0.35V _{CCB}		0.35V _{CCB}	V
		1.8	3.3			0.35V _{CCB}		0.35V _{CCB}	
		2.5	3.3			0.7		0.7	
V _{OHB}	High level output voltage	2.3	3.0	I _O =-100μA	2.1		2.1		V
		2.3	3.0	I _O =-18mA	1.7		1.7		
		1.65	3.0	I _O =-6mA	1.25		1.25		
		1.65	2.3	I _O =-6mA	1.25		1.25		
V _{OLB}	Low level output voltage	2.3	3.0	I _O =100μA		0.2		0.2	V
		2.3	3.0	I _O =18mA		0.60		0.60	
		1.65	3.0	I _O =6mA		0.30		0.30	
		1.65	2.3	I _O =6mA		0.30		0.30	
I _{IB}	Input leakage current	2.7	3.6	V _I = V _{CC} or GND		±0.5		±5	μA

Table 8. DC specification for V_{CCB} (continued)

Symbol	Parameter	Test condition			Value				Unit
		V_{CCB} (V)	V_{CCA} (V)		$T_A = 25\text{ }^\circ\text{C}$		-40 to 85°C		
					Min	Max	Min	Max	
$I_{IB(HOLD)}$	Input hold current	1.65	2.3	$V_I = 0.57\text{ V}$	25		25		μA
		1.65	2.3	$V_I = 1.07\text{ V}$	-25		-25		
		1.65	3.0	$V_I = 0.57\text{ V}$	25		25		
		1.65	3.0	$V_I = 1.07\text{ V}$	-25		-25		
		2.3	3.0	$V_I = 0.7\text{ V}$	45		45		
		2.3	3.0	$V_I = 1.6\text{ V}$	-45		-45		
		2.7	3.6	$V_I = 0\text{ to }2.7\text{ V}$				± 500	
I_{OZB}	High impedance output leakage current	2.7	3.6	$V_{IA} = V_{IHA}$ or V_{ILA} $V_{IB} = \text{GND}$ or 2.7 V $\bar{G} = V_{CCB}$		± 1.0		± 10	μA
I_{CCIB}	Quiescent supply current	1.95	3.6	$V_{IA} = V_{CCA}$ or GND	2			20	μA
		1.95	2.7	$V_{IB} = V_{CCB}$ or GND					
		2.7	3.6	Dir or $\bar{G} = V_{CCB}$ or GND $I/O_{VA1,2} = V_{CCA}$ or Open					
ΔI_{CCIB}	Maximum quiescent supply current / Input (Bn, DIR, \bar{G})	2.7	3.6	$V_{IB} = V_{CCB} - 0.6\text{ V}$ $V_{IA} = V_{CCA}$ or GND				0.75	mA
		1.95	3.6						
		1.95	2.7						

1. V_{CC} range = 3.3 ± 0.3 ; $2.5 \pm 0.2\text{ V}$ and $2.8 \pm 0.1\text{ V}$; $1.8 \pm 0.15\text{ V}$

Table 9. Dynamic switching characteristics

Symbol	Parameter	Test condition			Value					Unit
		V _{CCB} (V)	V _{CCA} (V)		T _A = 25 °C			-40 to 85 °C		
					Min	Typ	Max	Min	Max.	
V _{OLPA}	Dynamic low level quiet An output	1.8	2.5	C _L = 30 pF V _{IL} = 0 V V _{IH} = V _{CC}		0.25				V
		1.8	3.3			0.35				
		2.5	3.3			0.35				
V _{OLPB}	Dynamic low level quiet Bn output	1.8	2.5	C _L = 30 pF V _{IL} = 0 V V _{IH} = V _{CC}		0.25				V
		1.8	3.3			0.25				
		2.5	3.3			0.6				
V _{OLVA}	Dynamic low level quiet An output	1.8	2.5	C _L = 30 pF V _{IL} = 0 V V _{IH} = V _{CC}		-0.25				V
		1.8	3.3			-0.35				
		2.5	3.3			-0.35				
V _{OLVB}	Dynamic low level quiet Bn output	1.8	2.5	C _L = 30 pF V _{IL} = 0 V V _{IH} = V _{CC}		-0.25				V
		1.8	3.3			-0.25				
		2.5	3.3			-0.6				
V _{OHVA}	Dynamic high level quiet An output	1.8	2.5	C _L = 30 pF V _{IL} = 0 V V _{IH} = V _{CC}		2.1				V
		1.8	3.3			2.6				
		2.5	3.3			2.6				
V _{OHVB}	Dynamic high level quiet Bn output	1.8	2.5	C _L = 30 pF V _{IL} = 0 V V _{IH} = V _{CC}		1.7				V
		1.8	3.3			1.7				
		2.5	3.3			2.0				

Table 10. DC specification I²C lines

Symbol	Parameter	Test condition			Value				Unit
		V _{CCB} (V) (1)	V _{CCA} (V)		T _A = 25 °C		-40 to 85 °C		
					Min.	Max.	Min.	Max.	
V _{IH2}	High level input voltage (I/O _{VB1} , I/O _{VB2})	1.8	2.65 to 3.6		0.7 V _{CCB}	V _{CCB}	0.7 V _{CCB}	V _{CCB}	V
		1.8	2.65 to 3.6		0.7 V _{CCB}	V _{CCB}	0.7 V _{CCB}	V _{CCB}	
	High level input voltage (I/O _{VA1} , I/O _{VA2})	1.8	2.65 to 3.6		0.7 V _{CCA}	V _{CCA}	0.7 V _{CCA}	V _{CCA}	
		1.8	2.65 to 3.6		0.7 V _{CCA}	V _{CCA}	0.7 V _{CCA}	V _{CCA}	
V _{IL2}	Low level input voltage (I/O _{VB1} , I/O _{VB2})	1.8	2.65 to 3.6		0	0.25	0	0.25	V
		1.8	2.65 to 3.6		0	0.25	0	0.25	
	Low level input voltage (I/O _{VA1} , I/O _{VA2})	1.8	2.65 to 3.6		0	0.25	0	0.25	
		1.8	2.65 to 3.6		0	0.25	0	0.25	
V _{OH2}	High level output voltage (I/O _{VB1} , I/O _{VB2})	1.65	2.3	I _{OH} = -20 μA; V _{I/OVA} =V _{CCA}	V _{CCB} -0.4		V _{CCB} -0.4		V
	High level output voltage (I/O _{VA1} , I/O _{VA2})	1.65	2.3	I _{OH} = -20 μA; V _{I/OVB} =V _{CCB}	V _{CCA} -0.4		V _{CCA} -0.4		
V _{OL2}	Low level output voltage (I/O _{VB1} , I/O _{VB2}), (I/O _{VA1} , I/O _{VA2})	1.65	2.3	I _{OL} = 1 mA; V _{I/OVB} or V _{I/OVA} =GND		0.35		0.35	V

1. V_{CC} range = 1.8±0.15 V

Table 11. AC electrical characteristics

Symbol	Parameter	Test condition			Value		Unit
		V _{CCB} (V)	V _{CCA} (V)		-40 to 85 °C		
					Min	Max	
t _{PLH} t _{PHL}	Propagation delay time An to Bn	1.8 ± 0.15	2.5 ± 0.2	C _L = 30 pF R _L = 500 Ω	1.0	5.8	ns
		1.8 ± 0.15	3.3 ± 0.3		1.0	6.2	
		2.5 ± 0.2	3.3 ± 0.3		1.0	4.4	
t _{PLH} t _{PHL}	Propagation delay time Bn to An ⁽¹⁾	1.8 ± 0.15	2.5 ± 0.2	C _L = 30 pF R _L = 500 Ω	1.0	5.5	ns
		1.8 ± 0.15	3.3 ± 0.3		1.0	5.1	
		2.5 ± 0.2	3.3 ± 0.3		1.0	4.0	
t _{PZL} t _{PZH}	Output enable time Ḡ to An	1.8 ± 0.15	2.5 ± 0.2	C _L = 30 pF R _L = 500 Ω	1.0	5.3	ns
		1.8 ± 0.15	3.3 ± 0.3		1.0	5.1	
		2.5 ± 0.2	3.3 ± 0.3		1.0	4.0	
t _{PZL} t _{PZH}	Output enable time Ḡ to Bn	1.8 ± 0.15	2.5 ± 0.2	C _L = 30 pF R _L = 500 Ω	1.0	8.3	ns
		1.8 ± 0.15	3.3 ± 0.3		1.0	8.2	
		2.5 ± 0.2	3.3 ± 0.3		1.0	4.6	
t _{PLZ} t _{PHZ}	Output disable time Ḡ to An	1.8 ± 0.15	2.5 ± 0.2	C _L = 30 pF R _L = 500 Ω	1.0	5.2	ns
		1.8 ± 0.15	3.3 ± 0.3		1.0	5.6	
		2.5 ± 0.2	3.3 ± 0.3		1.0	4.8	
t _{PLZ} t _{PHZ}	Output disable time Ḡ to Bn	1.8 ± 0.15	2.5 ± 0.2	C _L = 30 pF R _L = 500 Ω	1.0	4.6	ns
		1.8 ± 0.15	3.3 ± 0.3		1.0	4.5	
		2.5 ± 0.2	3.3 ± 0.3		1.0	4.4	
t _{OSLH} t _{OSHL}	Output to output skew time ⁽²⁾ ⁽³⁾	1.8 ± 0.15	2.5 ± 0.2	C _L = 30 pF R _L = 500 Ω		0.5	ns
		1.8 ± 0.15	3.3 ± 0.3			0.5	
		2.5 ± 0.2	3.3 ± 0.3			0.75	

1. To add 2.5 ns at t_{PLH}, t_{PHL} max propagation delay time Bn to An at V_{CCB} = 1.8 ± 0.15 V; V_{CCA} = 2.8 ± 0.1 V; R_L = 500 Ω, when C_L = 60 pF.
2. Skew is defined as the absolute value of the difference between the actual propagation delay for any two outputs of the same device switching in the same direction, either HIGH or LOW (t_{OSLH} = |t_{PLHm} - t_{PLHn}|, t_{OSHL} = |t_{PHLm} - t_{PHLn}|).
3. Parameter guaranteed by design.

Table 12. AC I²C electrical characteristics

Symbol	Parameter	Test condition			Value		Unit
		V _{CCB} (V) ⁽¹⁾	V _{CCA} (V) ⁽¹⁾		-40 to 85 °C		
					Min.	Max.	
t _{ri/O}	Rise time I ² C input/output voltage (20% to 80%)	1.8 ± 0.15	2.5 ± 0.2	C _L = 15 pF t _{ri/O} = 15 ns		250	ns
		1.8 ± 0.15	3.3 ± 0.3				
		2.5 ± 0.2	3.3 ± 0.3				
t _{fi/O}	Fall time I ² C input/output voltage (80% to 20%)	1.8 ± 0.15	2.5 ± 0.2	C _L = 15 pF t _{fi/O} = 15 ns		250	ns
		1.8 ± 0.15	3.3 ± 0.3				
		2.5 ± 0.2	3.3 ± 0.3				
t _{PLH}	Propagation delay time I ² C I/O voltage (20% to 80%) (low to high)	1.8 ± 0.15	2.5 ± 0.2	C _L = 15 pF t _{ri/O} = 15 ns		100	ns
		1.8 ± 0.15	3.3 ± 0.3				
		2.5 ± 0.2	3.3 ± 0.3				
t _{PHL}	Propagation delay time I ² C I/O voltage (20% to 80%) high to low)	1.8 ± 0.15	2.5 ± 0.2	C _L = 15 pF t _{ri/O} = 15 ns		100	ns
		1.8 ± 0.15	3.3 ± 0.3				
		2.5 ± 0.2	3.3 ± 0.3				
f _{I/OVA} , f _{I/OVB}	I ² C lines data rate	1.8 ± 0.15	2.5 ± 0.2	C _L = 15 pF t _{ri/O} = 15 ns	400		KHz
		1.8 ± 0.15	3.3 ± 0.3				
		2.5 ± 0.2	3.3 ± 0.3				

1. V_{CC} range = 3.3±0.3; 2.5±0.2 V and 2.8 ± 0.1 V; 1.8 ± 0.15 V

Table 13. Capacitance characteristics

Symbol	Parameter	Test condition			Value					Unit
		V _{CCB} (V)	V _{CCA} (V)		T _A = 25 °C			-40 to 85 °C		
					Min	Typ	Max	Min	Max	
C _{INB}	Input capacitance	open	open			5				pF
C _{I/O}	Input/Output capacitance	2.5	3.3			6				pF
C _{PD} ⁽¹⁾	Power dissipation capacitance	2.5	3.3	f = 10MHz		28				pF
		1.8	3.3			28				pF

1. C_{PD} is defined as the value of the IC's internal equivalent capacitance which is calculated from the operating current consumption without load. (Refer to test circuit). Average current can be obtained by the following equation.

$$I_{CC(opr)} = C_{PD} \times V_{CC} \times f_{IN} + I_{CC}/14 \text{ (per circuit)}$$

5 Test circuit

Figure 4. Test circuit

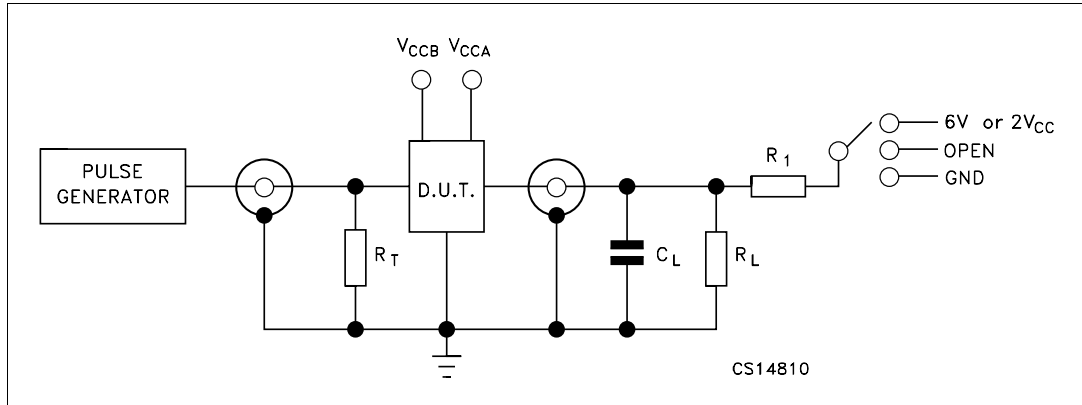

Table 14. Test circuit

Test	Switch
t_{PLH} , t_{PHL}	Open
t_{PZL} , t_{PLZ} ($V_{CC} = 3.0$ to 3.6 V)	6 V
t_{PZL} , t_{PLZ} ($V_{CC} = 2.3$ to 2.7 V or $V_{CC} = 1.65$ to 1.95 V)	$2V_{CC}$
t_{PZH} , t_{PHZ}	GND

$C_L = 10/30$ pF or equivalent (includes jig and probe capacitance)

$R_L = R_1 = 500\Omega$ or equivalent

$R_T = Z_{OUT}$ of pulse generator (typically 50Ω)

6 Waveforms

Table 15. Waveform symbol value

Symbol	V _{CC}		
	3.0 to 3.6 V	2.3 to 2.7 V	1.65 to 1.95 V
V _{IH}	V _{CC}	V _{CC}	V _{CC}
V _M	1.5V	V _{CC} /2	V _{CC} /2
V _X	V _{OL} +0.3V	V _{OL} +0.15V	V _{OL} +0.15V
V _Y	V _{OL} -0.3V	V _{OL} -0.15V	V _{OL} -0.15V

Figure 5. Waveform - propagation delay (f = 1 MHz; 50% duty cycle)

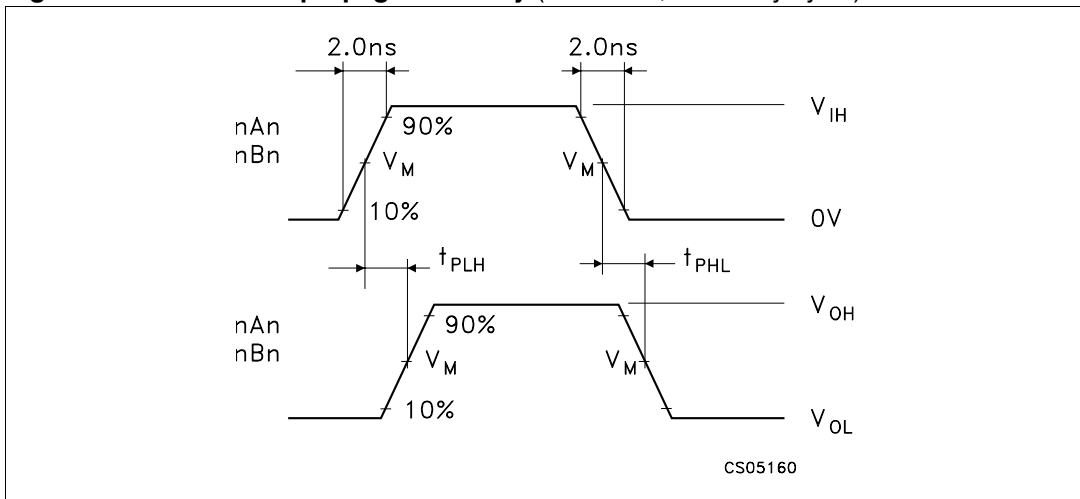

Figure 6. Waveform - output enable and disable time (f = 1 MHz; 50% duty cycle)

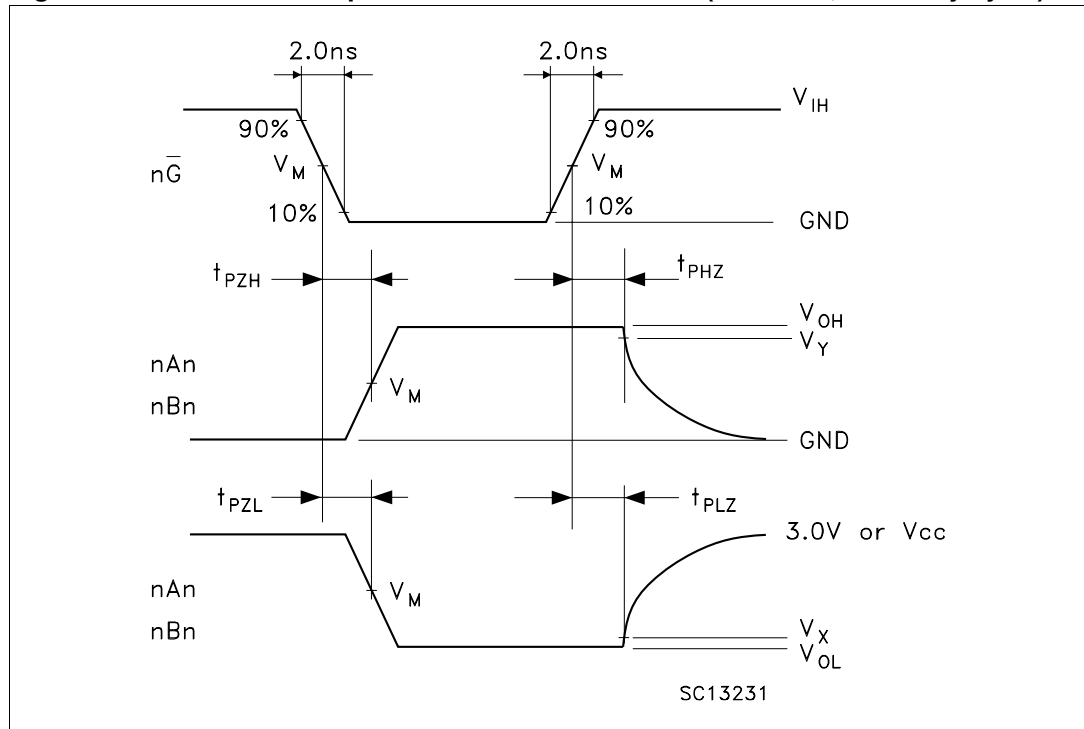
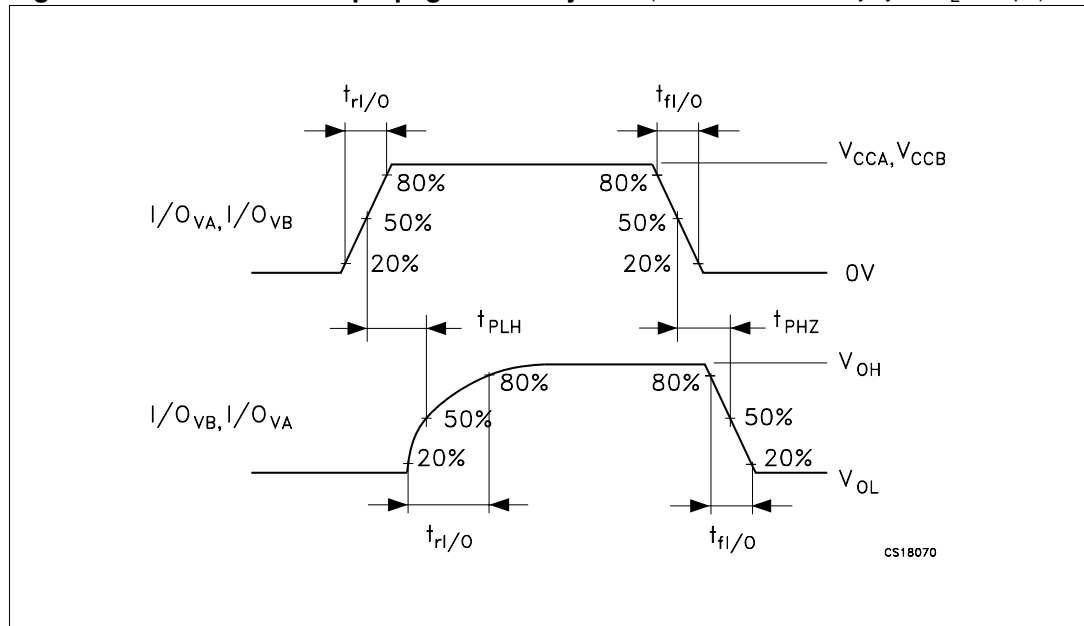

Figure 7. Waveform - I²C propagation delay time (f = 400 KHz; 50% duty cycle, C_L = 15 pF)



7 Package mechanical data

In order to meet environmental requirements, ST offers these devices in different grades of ECOPACK® packages, depending on their level of environmental compliance. ECOPACK® specifications, grade definitions and product status are available at: www.st.com. ECOPACK® is an ST trademark.

Figure 8. μ TFBGA42 mechanical data

μ TFBGA42 MECHANICAL DATA						
DIM.	mm.			mils		
	MIN.	TYP.	MAX.	MIN.	TYP.	MAX.
A	1.0	1.1	1.16	39.4	43.3	45.7
A1			0.25			9.8
A2	0.78		0.86	30.7		33.9
b	0.25	0.30	0.35	9.8	11.8	13.8
D	3.9	4.0	4.1	153.5	157.5	161.4
D1		3			118.1	
E	3.4	3.5	3.6	133.9	137.8	141.7
E1		2.5			98.4	
e		0.5			19.7	
SE		0.25			9.8	

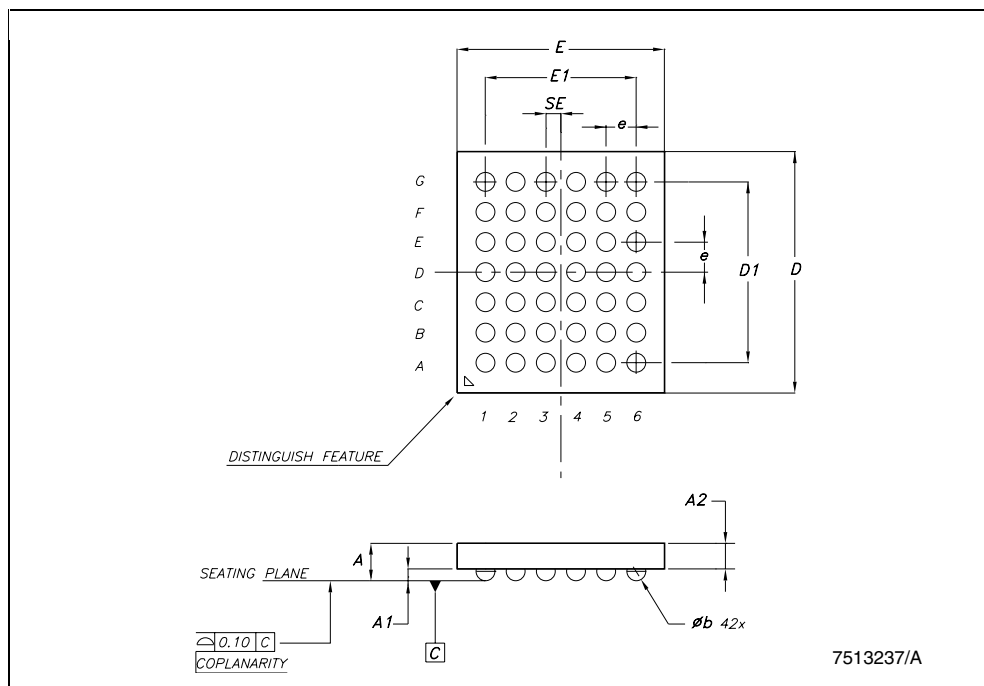

7513237/A

Figure 9. μ TFBGA42 tape and reel

Tape & Reel TFBGA42 MECHANICAL DATA						
DIM.	mm.			inch		
	MIN.	TYP.	MAX.	MIN.	TYP.	MAX.
A			330			12.992
C	12.8		13.2	0.504		0.519
D	20.2			0.795		
N	60			2.362		
T			14.4			0.567
Ao		3.8			0.149	
Bo		4.3			0.169	
Ko		1.05			0.041	
Po	3.9		4.1	0.153		0.161
P	7.9		8.1	0.311		0.319

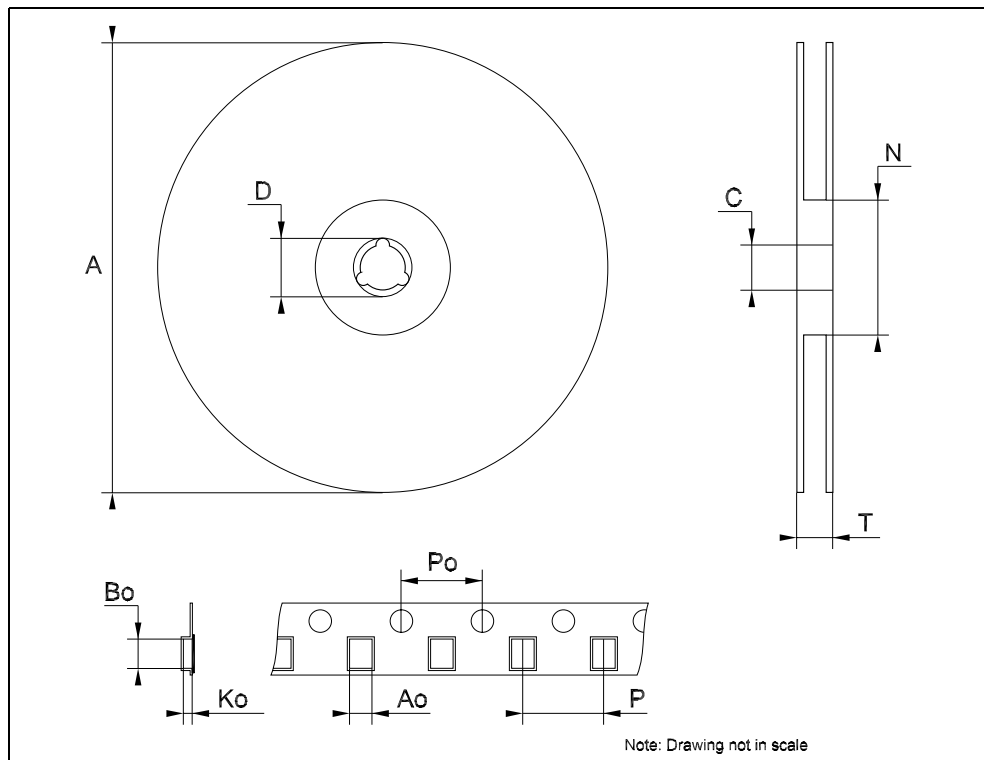

8 Revision history

Table 16. Document revision history

Date	Revision	Changes
01-Oct-2004	1	Initial release.
31-Mar-2005	2	Document status promoted from preliminary data to datasheet.
04-Mar-2009	3	Document reformatted. TSSOP and TFBGA54 packages removed.

Please Read Carefully:

Information in this document is provided solely in connection with ST products. STMicroelectronics NV and its subsidiaries ("ST") reserve the right to make changes, corrections, modifications or improvements, to this document, and the products and services described herein at any time, without notice.

All ST products are sold pursuant to ST's terms and conditions of sale.

Purchasers are solely responsible for the choice, selection and use of the ST products and services described herein, and ST assumes no liability whatsoever relating to the choice, selection or use of the ST products and services described herein.

No license, express or implied, by estoppel or otherwise, to any intellectual property rights is granted under this document. If any part of this document refers to any third party products or services it shall not be deemed a license grant by ST for the use of such third party products or services, or any intellectual property contained therein or considered as a warranty covering the use in any manner whatsoever of such third party products or services or any intellectual property contained therein.

UNLESS OTHERWISE SET FORTH IN ST'S TERMS AND CONDITIONS OF SALE ST DISCLAIMS ANY EXPRESS OR IMPLIED WARRANTY WITH RESPECT TO THE USE AND/OR SALE OF ST PRODUCTS INCLUDING WITHOUT LIMITATION IMPLIED WARRANTIES OF MERCHANTABILITY, FITNESS FOR A PARTICULAR PURPOSE (AND THEIR EQUIVALENTS UNDER THE LAWS OF ANY JURISDICTION), OR INFRINGEMENT OF ANY PATENT, COPYRIGHT OR OTHER INTELLECTUAL PROPERTY RIGHT.

UNLESS EXPRESSLY APPROVED IN WRITING BY AN AUTHORIZED ST REPRESENTATIVE, ST PRODUCTS ARE NOT RECOMMENDED, AUTHORIZED OR WARRANTED FOR USE IN MILITARY, AIR CRAFT, SPACE, LIFE SAVING, OR LIFE SUSTAINING APPLICATIONS, NOR IN PRODUCTS OR SYSTEMS WHERE FAILURE OR MALFUNCTION MAY RESULT IN PERSONAL INJURY, DEATH, OR SEVERE PROPERTY OR ENVIRONMENTAL DAMAGE. ST PRODUCTS WHICH ARE NOT SPECIFIED AS "AUTOMOTIVE GRADE" MAY ONLY BE USED IN AUTOMOTIVE APPLICATIONS AT USER'S OWN RISK.

Resale of ST products with provisions different from the statements and/or technical features set forth in this document shall immediately void any warranty granted by ST for the ST product or service described herein and shall not create or extend in any manner whatsoever, any liability of ST.

ST and the ST logo are trademarks or registered trademarks of ST in various countries.

Information in this document supersedes and replaces all information previously supplied.

The ST logo is a registered trademark of STMicroelectronics. All other names are the property of their respective owners.

© 2009 STMicroelectronics - All rights reserved

STMicroelectronics group of companies

Australia - Belgium - Brazil - Canada - China - Czech Republic - Finland - France - Germany - Hong Kong - India - Israel - Italy - Japan - Malaysia - Malta - Morocco - Singapore - Spain - Sweden - Switzerland - United Kingdom - United States of America

www.st.com



Looking for pricing, stock, or lifecycle information?

Click below to explore more details on WIN SOURCE:

- ⊖ [View ST16C32245TBR](#) on WIN SOURCE
- ⊖ [STMicroelectronics](#) Information

Optimize Your Supply Chain with WIN SOURCE Solutions

- ✓ Global Sourcing Solution
- ✓ Obsolete Management
- ✓ Cost Control Management
- ✓ Shortage Management
- ✓ Alternative Solution
- ✓ Excess Inventory Management