



**THE DATASHEET OF
ST10R272LT6**





16-BIT LOW VOLTAGE ROMLESS MCU WITH MAC

DATASHEET

- High Performance 16-bit CPU
 - CPU Frequency: 0 to 50 MHz
 - 40ns instruction cycle time at 50-MHz CPU clock
 - Multiply-Accumulate unit (MAC)
 - 4-stage pipeline
 - Register-based design with multiple variable register banks
 - Enhanced boolean bit manipulation facilities
 - Additional instructions to support HLL and operating systems
 - Single-cycle context switching support
 - 1024 bytes on-Chip special function register area
- Memory Organisation
 - 1KByte on-chip RAM
 - Up to 16 MBytes linear address space for code and data (1 MByte with SSP used)
- External Memory Interface
 - Programmable external bus characteristics for different address ranges
 - 8-bit or 16-bit external data bus
 - Multiplexed or demultiplexed external address/data buses
 - Five programmable chip-select signals
 - Hold and hold-acknowledge bus arbitration support
- One Channel PWM Unit
 - Fail Safe Protection
 - Programmable watchdog timer
 - Oscillator Watchdog
- Interrupt
 - 8-channel interrupt-driven single-cycle data transfer facilities via peripheral event controller (PEC)
 - 16-priority-level interrupt system with 17 sources, sample-rate down to 40 ns

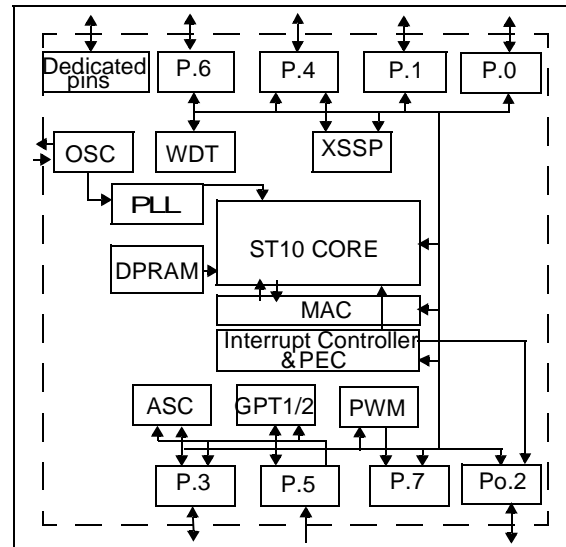

- Timers
 - Two multi-functional general purpose timer units with 5 timers
 - Clock Generation via on-chip PLL, or via direct or prescaled clock input
- Serial Channels
 - Synchronous/asynchronous
 - High-speed-synchronous serial port SSP
- Up to 77 general purpose I/O lines
- No bootstrap loader
- Electrical Characteristics
 - 5V Tolerant I/Os
 - 5V Fail-Safe Inputs (Port 5)
 - Power: 3.3 Volt +/-0.3V
 - Idle and power down modes
- Support
 - C-compilers, macro-assembler packages, emulators, evaluation boards, HLL-debuggers, simulators, logic analyser disassemblers, programming boards
- Package
 - 100-Pin Thin Quad Flat Pack (TQFP)

Rev. 1.3

Table of Contents

1 PIN DESCRIPTION	4
2 FUNCTIONAL DESCRIPTION	11
3 MEMORY MAPPING	12
4 CENTRAL PROCESSING UNIT	13
5 MULTIPLY-ACCUMULATE UNIT (MAC)	14
5.1 MAC FEATURES	15
5.2 MAC OPERATION	16
6 INTERRUPT AND TRAP FUNCTIONS	22
6.1 INTERRUPT SOURCES	23
6.2 HARDWARE TRAPS	24
7 PARALLEL PORTS	25
8 EXTERNAL BUS CONTROLLER	25
9 PWM MODULE	26
10 GENERAL PURPOSE TIMERS	27
10.1 GPT1	27
10.2 GPT2	29
11 SERIAL CHANNELS	30
12 WATCHDOG TIMER	32
13 SYSTEM RESET	33
14 POWER REDUCTION MODES	34
15 SPECIAL FUNCTION REGISTERS	34
16 ELECTRICAL CHARACTERISTICS	40
16.1 ABSOLUTE MAXIMUM RATINGS	40
16.2 DC CHARACTERISTICS	42

Table of Contents

16.3 AC CHARACTERISTICS	45
16.3.1 CPU Clock Generation Mechanisms	47
16.3.2 Memory Cycle Variables	51
16.3.3 Multiplexed Bus	52
16.3.4 Demultiplexed Bus	59
16.3.5 CLKOUT and $\overline{\text{READY}}$ /READY	66
16.3.6 External Bus Arbitration	69
16.3.7 External Hardware Reset	72
16.3.8 Synchronous Serial Port Timing	75
17 PACKAGE MECHANICAL DATA	77
18 ORDERING INFORMATION	77

Symbol	Pin Number (TQFP)	Input (I) Output (O)	Kind ¹⁾	Function
P5.10 -P5.15	98-100 1- 3 98 99 100 1 2 3	I I I I I I I	5S 5S 5S 5S 5S 5S 5S	6-bit input-only port with Schmitt-Trigger characteristics. Port 5 pins also serve as timer inputs: P5.10 T6EUD GPT2 Timer T6 Ext.Up/Down Ctrl.Input P5.11 T5EUD GPT2 Timer T5 Ext.Up/Down Ctrl.Input P5.12 T6IN GPT2 Timer T6 Count Input P5.13 T5IN GPT2 Timer T5 Count Input P5.14 T4EUD GPT1 Timer T4 Ext.Up/Down Ctrl.Input P5.15 T2EUD GPT1 Timer T2 Ext.Up/Down Ctrl.Input
XTAL1	5	I	3T	XTAL1: Input to the oscillator amplifier and internal clock generator
XTAL2	6	O	3T	XTAL2: Output of the oscillator amplifier circuit. To clock the device from an external source, drive XTAL1, while leaving XTAL2 unconnected. Observe minimum and maximum high/low and rise/fall times specified in the AC Characteristics.

Table 1 Pin definitions

ST10R272L - PIN DESCRIPTION

Symbol	Pin Number (TQFP)	Input (I) Output (O)	Kind ¹⁾	Function	
P3.0 – P3.13	8-21	I/O	5T	<p>A 15-bit (P3.14 is missing) bidirectional I/O port. Port 3 is bit-wise programmable for input or output via direction bits. For a pin configured as input, the output driver is put into high-impedance state. Port 3 outputs can be configured as push/pull or open drain drivers. The following pins have alternate functions:</p>	
P3.15	22	I/O	5T		
	9	O	5T		P3.1 T6OUT GPT2 Timer T6 toggle latch output
	10	I	5T		P3.2 CAPIN GPT2 Register CAPREL capture input
	11	O	5T		P3.3 T3OUT GPT1 Timer T3 toggle latch output
	12	I	5T		P3.4 T3EUD GPT1 Timer T3 ext.up/down ctrl.input
	13	I	5T		P3.5 T4IN GPT1 Timer T4 input for count/gate/reload/capture
	14	I	5T		P3.6 T3IN GPT1 Timer T3 count/gate input
	15	I	5T		P3.7 T2IN GPT1 Timer T2 input for count/gate/reload/capture
	18	O	5T		P3.10 TxD0 ASC0 clock/data output (asyn./syn.)
	19	I/O	5T		P3.11 RxD0 ASC0 data input (asyn.) or I/O (syn.)
	20	O	5T		P3.12 $\overline{\text{BHE}}$ Ext. Memory High Byte Enable Signal
		O	5T		$\overline{\text{WRH}}$ Ext. Memory High Byte Write Strobe
	22	O	5T	P3.15 CLKOUT System clock output (=CPU clock)	

Table 1 Pin definitions

Symbol	Pin Number (TQFP)	Input (I) Output (O)	Kind ⁽¹⁾	Function
P4.0– P4.7	23-26 29-32-	I/O	5T	An 8-bit bidirectional I/O port. Port 8 is bit-wise programmable for input or output via direction bits. For a pin configured as input, the output driver is put into high-impedance state. Port 4 can be used to output the segment address lines for external bus configuration.
	23	O	5T	P4.0 A16 Least Significant Segment Addr. Line

	26	O	5T	P4.3 A19 Segment Address Line
	29	O	5T	P4.4 A20 Segment Address Line
				SSPCE1 Chip Enable Line 1
	30	O	5T	P4.5 A21 Segment Address Line
				SSPCE0 SSPChip Enable Line 0
	31	O	5T	P4.6 A22 Segment Address Line
				SSPDAT SSP Data Input/Output Line
32	O	5T	P4.7 A23 Most Significant Segment Addr. Line	
			SSPCLK SSP Clock Output Line	
\overline{RD}	33	O	5T	External Memory Read Strobe. RD is activated for every external instruction or data read access.
$\overline{WR}/$ \overline{WRL}	34	O	5T	External Memory Write Strobe. In WR-mode, this pin is activated for every external data write access. In WRL-mode, this pin is activated for low byte data write accesses on a 16-bit bus, and for every data write access on an 8-bit bus. See WRCFG in the SYSCON register for mode selection.
$\overline{READY}/$ \overline{READY}	35	I	5T	Ready Input. Active level is programmable. When the Ready function is enabled, the selected inactive level at this pin during an external memory access will force the insertion of memory cycle time waitstates until the pin returns to the selected active level. Polarity is programmable.

Table 1 Pin definitions

ST10R272L - PIN DESCRIPTION

Symbol	Pin Number (TQFP)	Input (I) Output (O)	Kind ⁽¹⁾	Function																		
ALE	36	O	5T	Address Latch Enable Output. Can be used for latching the address into external memory or an address latch in the multiplexed bus modes.																		
\overline{EA}	37	I	5T	External Access Enable pin. Low level at this pin during and after reset forces the ST10R272L to begin instruction execution out of external memory. A high level forces execution out of the internal ROM. The ST10R272L must have this pin tied to '0'.																		
PORT0: P0L.0– P0L.7, P0H.0 - P0H.7	41 - 48 51 - 58	I/O	5T	<p>PORT0 has two 8-bit bidirectional I/O ports P0L and P0H. It is bit-wise programmable for input or output via direction bits. For a pin configured as input, the output driver is put into high-impedance state.</p> <p>For external bus configuration, PORT0 acts as address (A) and address/data (AD) bus in multiplexed bus modes and as the data (D) bus in demultiplexed bus modes.</p> <p>Demultiplexed bus modes</p> <table> <tr> <td>Data Path Width:</td> <td>8-bit</td> <td>16-bit</td> </tr> <tr> <td>P0L.0 – P0L.7:</td> <td>D0 – D7</td> <td>D0 - D7</td> </tr> <tr> <td>P0H.0 – P0H.7:</td> <td>I/O</td> <td>D8 - D15</td> </tr> </table> <p>Multiplexed bus modes</p> <table> <tr> <td>Data Path Width:</td> <td>8-bit</td> <td>16-bit</td> </tr> <tr> <td>P0L.0 – P0L.7:</td> <td>AD0 – AD7</td> <td>AD0 - AD7</td> </tr> <tr> <td>P0H.0 – P0H.7:</td> <td>A8 – A15</td> <td>AD8 – AD15</td> </tr> </table>	Data Path Width:	8-bit	16-bit	P0L.0 – P0L.7:	D0 – D7	D0 - D7	P0H.0 – P0H.7:	I/O	D8 - D15	Data Path Width:	8-bit	16-bit	P0L.0 – P0L.7:	AD0 – AD7	AD0 - AD7	P0H.0 – P0H.7:	A8 – A15	AD8 – AD15
Data Path Width:	8-bit	16-bit																				
P0L.0 – P0L.7:	D0 – D7	D0 - D7																				
P0H.0 – P0H.7:	I/O	D8 - D15																				
Data Path Width:	8-bit	16-bit																				
P0L.0 – P0L.7:	AD0 – AD7	AD0 - AD7																				
P0H.0 – P0H.7:	A8 – A15	AD8 – AD15																				
PORT1: P1L.0– P1L.7, P1H.0 - P1H.7	59- 66 67, 68 71-76	I/O	5T	<p>PORT1 has two 8-bit bidirectional I/O ports P1L and P1H. It is bit-wise programmable for input or output via direction bits. For a pin configured as input, the output driver is put into high-impedance state. PORT1 acts as a 16-bit address bus (A) in demultiplexed bus modes and also after switching from a demultiplexed bus mode to a multiplexed bus mode.</p>																		

Table 1 Pin definitions

Symbol	Pin Number (TQFP)	Input (I) Output (O)	Kind ⁽¹⁾	Function
$\overline{\text{RSTIN}}$	79	I	5T	Reset Input with Schmitt-Trigger characteristics. Resets the device when a low level is applied for a specified duration while the oscillator is running. An internal pullup resistor enables power-on reset using <u>only</u> a capacitor connected to V_{SS} . With a bonding option, the $\overline{\text{RSTIN}}$ pin can also be pulled-down for 512 internal clock cycles for hardware, software or watchdog timer triggered resets
$\overline{\text{RSTOUT}}$	80	O	5T	Internal Reset Indication Output. This pin is set to a low level when the part is executes hardware-, software- or watchdog timer reset. $\overline{\text{RSTOUT}}$ remains low until the EINIT (end of initialization) instruction is executed.
$\overline{\text{NMI}}$	81	I	5S	Non-Maskable Interrupt Input. A high to low transition at this pin causes the CPU to vector to the NMI trap routine. If it is not used, $\overline{\text{NMI}}$ should be pulled high externally.
P6.0- P6.7	82-89	I/O	5T	An 8-bit bidirectional I/O port. Port 6 is bit-wise programmable for input or output via direction bits. For a pin configured as input, the output driver is put into high-impedance state. Port 6 outputs can be configured as push/pull or open drain drivers. The following Port 6 pins have alternate functions:
	82	O	5T	P6.0 $\overline{\text{CS0}}$ Chip Select 0 Output

	86	O	5T	P6.4 $\overline{\text{CS4}}$ Chip Select 4 Output
	87	I	5T	P6.5 $\overline{\text{HOLD}}$ External Master Hold Request Input (Master mode: O, Slave mode: I)
	88	I/O	5T	P6.6 $\overline{\text{HLDA}}$ Hold Acknowledge Output
	89	O	5T	P6.7 $\overline{\text{BREQ}}$ Bus Request Output

Table 1 Pin definitions

ST10R272L - PIN DESCRIPTION

Symbol	Pin Number (TQFP)	Input (I) Output (O)	Kind ¹⁾	Function
P2.8 – P2.11	90 - 93	I/O	5T	Port 2 is a 4-bit bidirectional I/O port. It is bit-wise programmable for input or output via direction bits. For a pin configured as input, the output driver is put into high-impedance state. Port 2 outputs can be configured as push/pull or open drain drivers. The following Port 2 pins have alternate functions:
	90	I	5T	P2.8 EX0IN Fast External Interrupt 0 Input

	93	I	5T	P2.11 EX3IN Fast External Interrupt 3 Input
P7.0 – P7.3	94 - 97	I/O	5T	Port 7 is a 4-bit bidirectional I/O port. It is bit-wise programmable for input or output via direction bits. For a pin configured as input, the output driver is put into high-impedance state. Port 7 outputs can be configured as push/pull or open drain drivers. The following Port 7 pins have alternate functions:
	97	O	5T	P7.3 POUT3 PWM (Channel 3) Output
RPD	40	I/O	5T	Input timing pin for the return from powerdown circuit and power-up asynchronous reset.
V _{DD}	7, 28, 38, 49, 69, 78	-	PO	Digital supply voltage.
V _{SS}	4, 27, 39, 50, 70, 77	-	PO	Digital ground.

Table 1 Pin definitions

- 1) The following I/O kinds are used. Refer to *ELECTRICAL CHARACTERISTICS* on page 40 for a detailed description.

PO: Power pin

3T: 3 V tolerant pin (voltage max. respect to V_{ss} is -0.5 to V_{DD} + 0.5)

5V: 5 V tolerant pin (voltage max. respect to V_{ss} is -0.5 to 5.5 only if chip is powered)

5S: 5 V tolerant and fail-safe pin (-0.5-5.5 max. voltage w.r.t. V_{ss} even if chip is not powered).

2 FUNCTIONAL DESCRIPTION

ST10R272L architecture combines the advantages of both RISC and CISC processors with an advanced peripheral subsystem. The following block diagram overviews the different on-chip components and the internal bus structure.

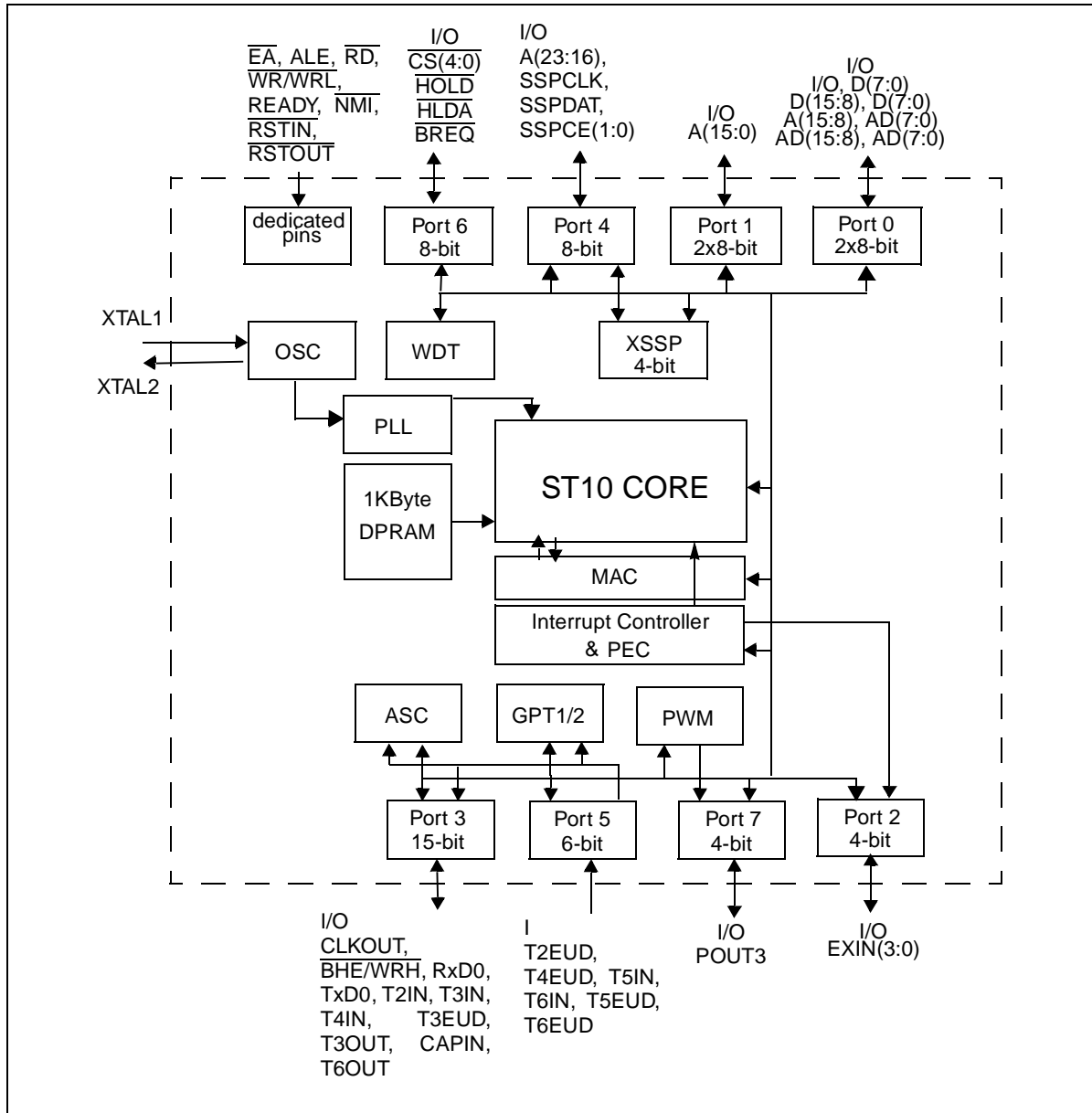

Figure 2 Block diagram

3 MEMORY MAPPING

The ST10R272L is a ROMless device, the internal RAM space is 1 KByte. The RAM address space is used for variables, register banks, the system stack, the PEC pointers (in 00'FCE0h - 00'FCFFh) and the bit-addressable space (in 00'FD00h - 00'FDFFh).

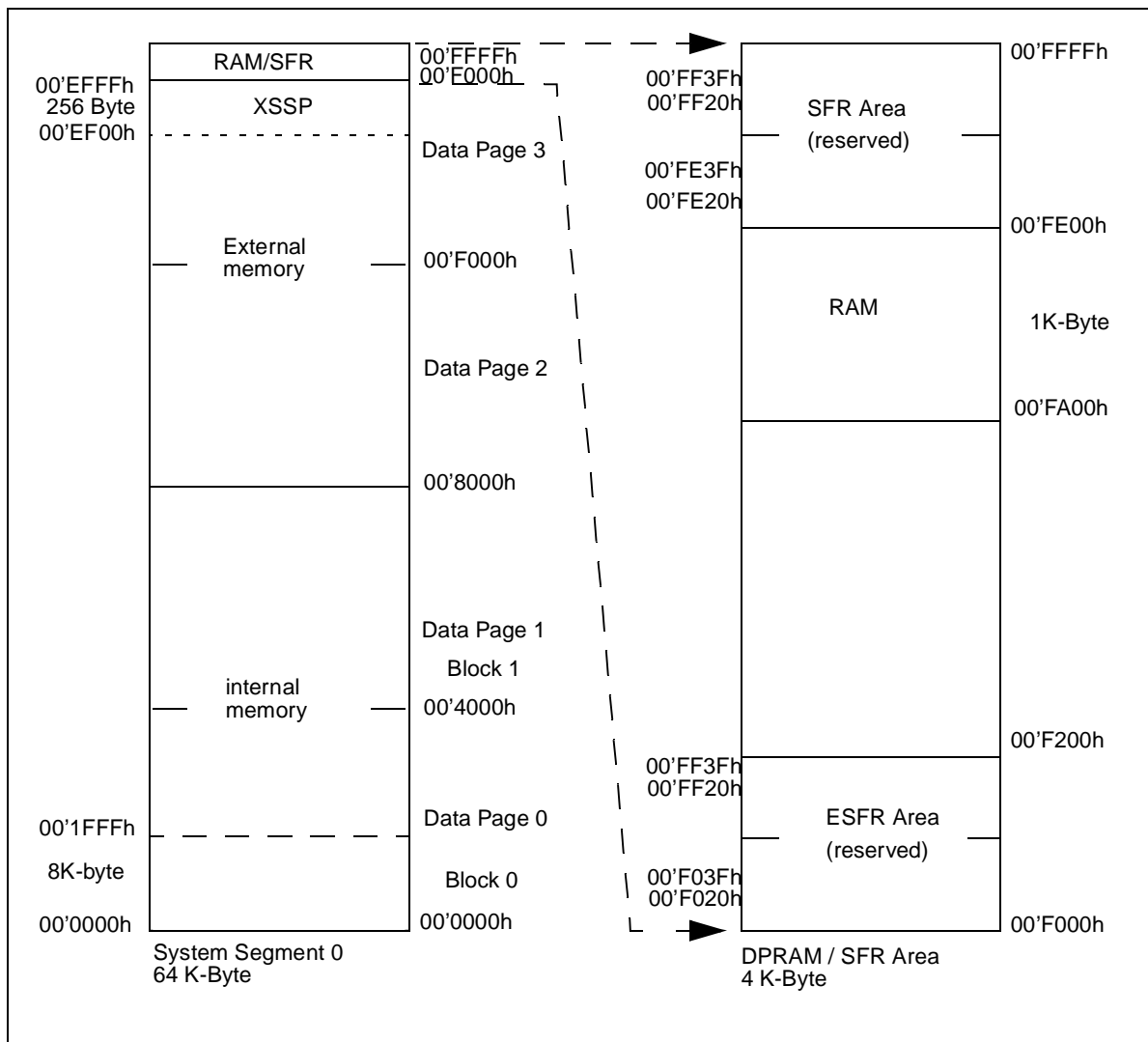

Figure 3 Memory map

4 CENTRAL PROCESSING UNIT

The main core of the CPU contains a 4-stage instruction pipeline, a MAC multiply-accumulation unit, a separate multiply and divide unit, a bit-mask generator and a barrel shifter. Most instructions can be executed in one machine cycle requiring 40ns at 50MHz CPU clock.

The CPU includes an actual register context consisting of 16 wordwide GPRs physically located in the on-chip RAM area. A Context Pointer (CP) register determines the base address of the active register bank to be accessed by the CPU. The number of register banks is only restricted by the available internal RAM space. For easy parameter passing, one register bank may overlap others.

A system stack of up to 1024 bytes is provided as a storage for temporary data. The system stack is allocated in the on-chip RAM area, and it is accessed by the CPU via the stack pointer (SP) register. Two separate SFRs, STKOV and STKUN, are compared against the stack pointer value during each stack access to detect stack overflow or underflow.

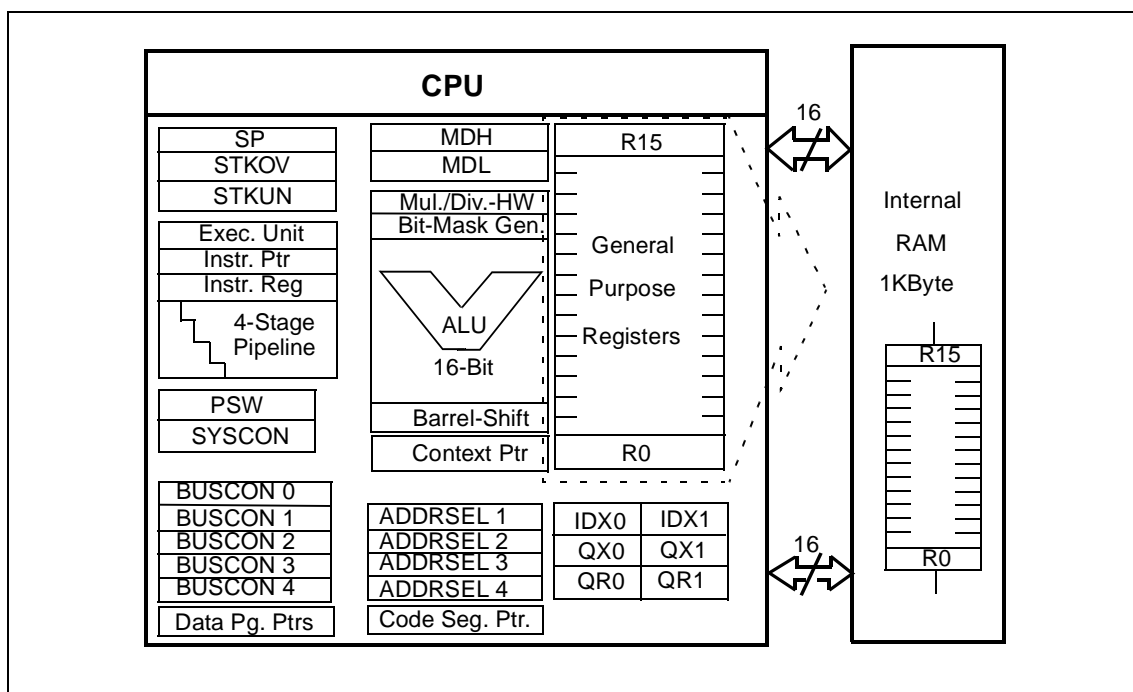

Figure 4 CPU block diagram

5 MULTIPLY-ACCUMULATE UNIT (MAC)

The MAC is a specialized co-processor added to the ST10R272L CPU core to improve the performance of signal processing algorithms. It includes:

- a multiply-accumulate unit
- an address generation unit, able to feed the mac unit with 2 operands per cycle
- a repeat unit, to execute a series of multiply-accumulate instructions

New addressing capabilities enable the CPU to supply the MAC with up to 2 operands per instruction cycle. MAC instructions: multiply, multiply-accumulate, 32-bit signed arithmetic operations and the CoMOV transfer instruction have been added to the standard instruction set. Full details are provided in the ‘ST10 Family Programming Manual’.

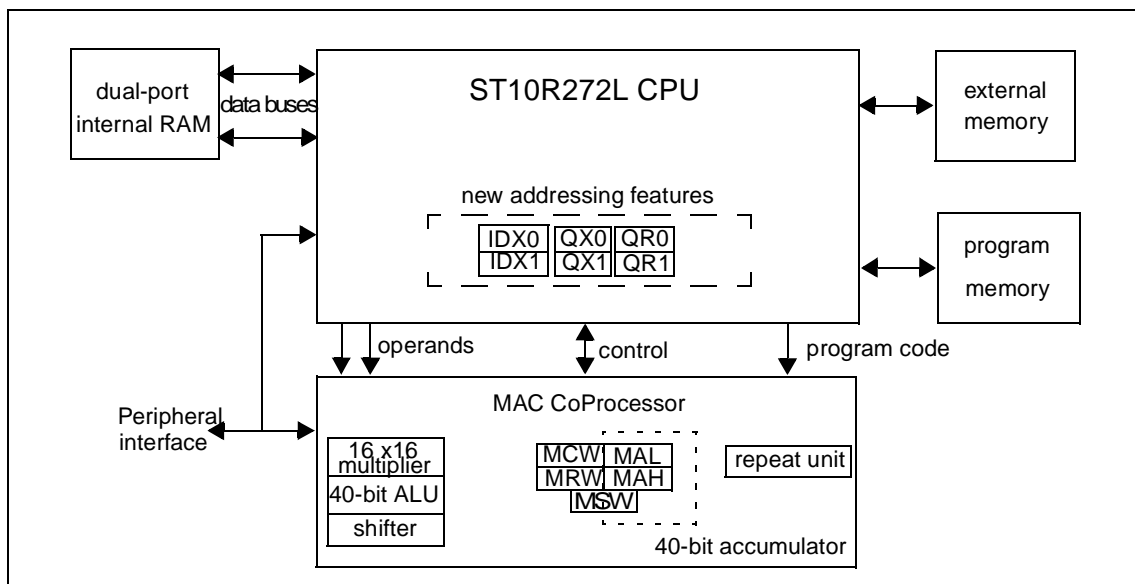

Figure 5 MAC architecture

5.1 MAC Features

Enhanced addressing capabilities

- Double indirect addressing mode with pointer post-modification.
- Parallel Data Move allows one operand move during Multiply-Accumulate instructions without penalty.
- CoSTORE instruction (for fast access to the MAC SFRs) and CoMOV (for fast memory to memory table transfer).

General

- Two-cycle execution for all MAC operations.
- 16 x 16 signed/unsigned parallel multiplier.
- 40-bit signed arithmetic unit with automatic saturation mode.
- 40-bit accumulator.
- 8-bit left/right shifter.
- Scaler (one-bit left shifter)
- Data limiter
- Full instruction set with multiply and multiply-accumulate, 32-bit signed arithmetic and compare instructions.
- Three 16-bit status and control registers: MSW: MAC Status Word, MCW: MAC Control Word, MRW: MAC Repeat Word.

Program control

- Repeat Unit allows some MAC co-processor instructions to be repeated up to 8192 times. Repeated instructions may be interrupted.
- MAC interrupt (Class B Trap) on MAC condition flags.

5.2 MAC Operation

Instruction pipelining

All MAC instructions use the 4-stage pipeline. During each stage the following tasks are performed:

- **FETCH:** All new instructions are double-word instructions.
- **DECODE:** If required, operand addresses are calculated and the resulting operands are fetched. IDX and GPR pointers are post-modified if necessary.
- **EXECUTE:** Performs the MAC operation. At the end of the cycle, the Accumulator and the MAC condition flags are updated if required. Modified GPR pointers are written-back during this stage, if required.
- **WRITEBACK:** Operand write-back in the case of parallel data move.

Note At least one instruction which does not use the MAC must be inserted between two instructions that read from a MAC register. This is because the Accumulator and the status of the MAC are modified during the Execute stage. The CoSTORE instruction has been added to allow access to the MAC registers immediately after a MAC operation.

Address generation

MAC instructions can use some standard ST10 addressing modes such as GPR direct or #data4 for immediate shift value.

New addressing modes have been added to supply the MAC with two new operands per instruction cycle. These allow indirect addressing with address pointer post-modification.

Double indirect addressing requires two pointers. Any GPR can be used for one pointer, the other pointer is provided by one of two specific SFRs IDX0 and IDX1. Two pairs of offset registers QR0/QR1 and QX0/QX1 are associated with each pointer (GPR or IDX_i). The GPR pointer allows access to the entire memory space, but IDX_i are limited to the internal Dual-Port RAM, except for the CoMOV instruction.

The following table shows the various combinations of pointer post-modification for each of these 2 new addressing modes. In this document the symbols “[Rw_n⊗]” and “[IDX_i⊗]” refer to these addressing modes.

Symbol	Mnemonic	Address Pointer Operation
“[IDX _i ⊗]” stands for	[IDX _i]	(IDX _i) ← (IDX _i) (no-op)
	[IDX _i +]]	(IDX _i) ← (IDX _i) +2 (i=0,1)
	[IDX _i -]	(IDX _i) ← (IDX _i) -2 (i=0,1)
	[IDX _i + QX _j]	(IDX _i) ← (IDX _i) + (QX _j) (i, j =0,1)
	[IDX _i - QX _j]	(IDX _i) ← (IDX _i) - (QX _j) (i, j =0,1)
“[Rw _n ⊗]” stands for	[Rwn]	(Rwn) ← (Rwn) (no-op)
	[Rwn+]]	(Rwn) ← (Rwn) +2 (n=0-15)
	[Rwn-]	(Rwn) ← (Rwn) -2 (k=0-15)
	[Rwn+QR _j]	(Rwn) ← (Rwn) + (QR _j) (n=0-15; j =0,1)
	[Rwn - QR _j]	(Rwn) ← (Rwn) - (QR _j) (n=0-15; j =0,1)

Table 2 Pointer post-modification combinations for IDX_i and Rwn

For the CoMACM class of instruction, Parallel Data Move mechanism is implemented. This class of instruction is only available with double indirect addressing mode. Parallel Data Move allows the operand pointed by IDX_i to be moved to a new location in parallel with the MAC operation. The write-back address of Parallel Data Move is calculated depending on the post-modification of IDX_i. It is obtained by the reverse operation than the one used to calculate the new value of IDX_i. The following table shows these rules.

Instruction	Writeback Address
CoMACM [IDX _i +] ,...	<IDX _i -2>
CoMACM [IDX _i -] ,...	<IDX _i +2>
CoMACM [IDX _i +QX _j],...	<IDX _i -QX _j >
CoMACM [IDX _i -QX _j],...	<IDX _i +QX _j >

Table 3 Parallel data move addressing

ST10R272L - MULTIPLY-ACCUMULATE UNIT (MAC)

The Parallel Data Move shifts a table of operands in parallel with a computation on those operands. Its specific use is for signal processing algorithms like filter computation. The following figure gives an example of Parallel Data Move with CoMACM instruction.

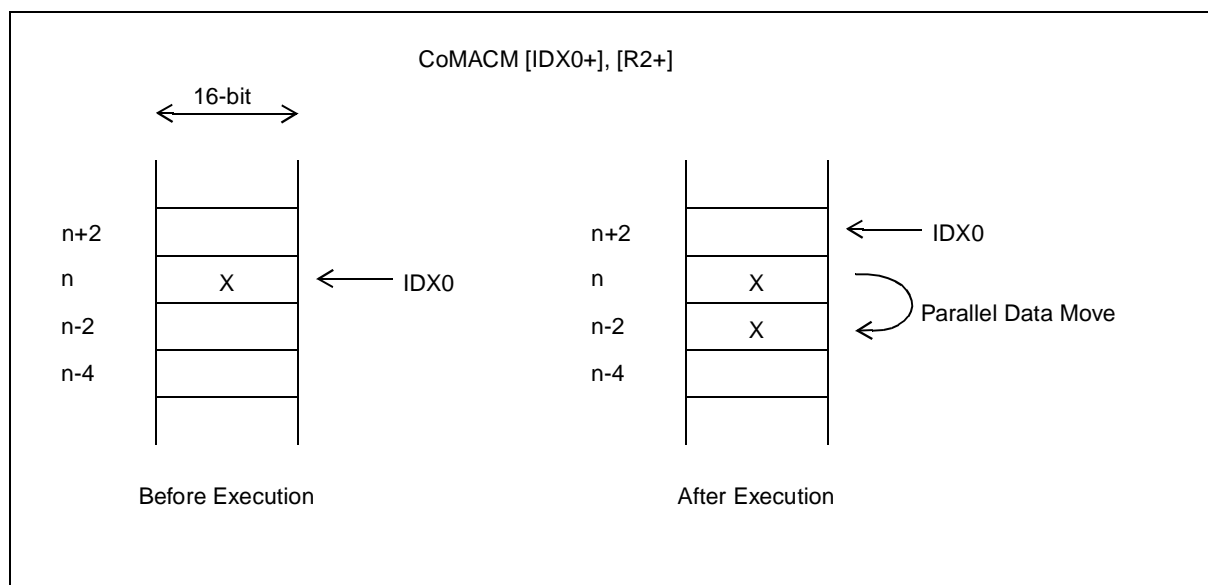

Figure 6 Example of parallel data move

16 x 16 signed/unsigned parallel multiplier

The multiplier executes 16 x 16-bit parallel signed/unsigned fractional and integer multiplies. The multiplier has two 16-bit input ports, and a 32-bit product output port. The input ports can accept data from the MA-bus and from the MB-bus. The output is sign-extended and then feeds a scaler that shifts the multiplier output according to the shift mode bit MP specified in the co-processor Control Word (MCW). The product can be shifted one bit left to compensate for the extra sign bit gained in multiplying two 16-bit signed (2's complement) fractional numbers if bit MP is set.

40-bit signed arithmetic unit

The arithmetic unit over 32 bits wide to allow intermediate overflow in a series of multiply/accumulate operations. The extension flag E, contained in the most significant byte of MSW, is set when the Accumulator has overflowed beyond the 32-bit boundary, that is, when there are significant (non-sign) bits in the top eight (signed arithmetic) bits of the Accumulator.

The 40-bit arithmetic unit has two 40-bit input ports A and B. The A-input port accepts data from 4 possible sources: 00,0000,0000h, 00,0000,8000h (round), the sign-extended product, or the sign-extended data conveyed by the 32-bit bus resulting from the concatenation of MA- and MB-buses. Product and Concatenation can be shifted left by one according to MP for the multiplier or to the instruction for the concatenation. The B-input port is fed either by the 40-bit shifted/not shifted and inverted/not inverted accumulator or by 00,0000,0000h. A-input and B-

input ports can receive 00,0000,0000h to allow direct transfers from the B-source and A-source, respectively, to the Accumulator (case of Multiplication, Shift.). The output of the arithmetic unit goes to the Accumulator.

It is also possible to saturate the Accumulator on a 32-bit value, automatically after every accumulation. Automatic saturation is enabled by setting the saturation bit MS in the MCW register. When the Accumulator is in the saturation mode and an 32-bit overflow occurs, the accumulator is loaded with either the most positive or the most negative value representable in a 32-bit value, depending on the direction of the overflow. The value of the Accumulator upon saturation is 00,7fff,ffffh (positive) or ff,8000,0000h (negative) in signed arithmetic. Automatic saturation sets the SL flag MSW. This flag is a sticky flag which means it stays set until it is explicitly reset by the user.

40-bit overflow of the Accumulator sets the SV flag in MSW. This flag is also a sticky flag.

40-bit accumulator register

The 40-bit Accumulator consists of three SFR registers MAH, MAL and MAE. MAH and MAL are 16-bit wide. MAE is 8-bit wide and is contained within the least significant byte of MSW. Most co-processor operations specify the 40-bit Accumulator register as source and/or destination operand.

Data limiter

Saturation arithmetic is also provided to selectively limit overflow, when reading the accumulator by means of a CoSTORE <destination> MAS instruction. Limiting is performed on the MAC Accumulator. If the contents of the Accumulator can be represented in the destination operand size without overflow, the data limiter is disabled and the operand is not modified. If the contents of the accumulator cannot be represented without overflow in the destination operand size, the limiter will substitute a 'limited' data as explained in the following table.

Register	E bit	N bit	Output of the Limiter
x	0	x	unchanged
MAS	1	0	7fffh
MAS	1	1	8000h

Table 4 Data Limit Values

Note In this case, the accumulator and the status register are not affected. MAS readable from a CoSTORE instruction.

Accumulator shifter

The Accumulator shifter is a parallel shifter with a 40-bit input and a 40-bit output. The source operand of the shifter is the Accumulator and the possible shifting operations are:

- No shift (Unmodified)
- Up to 8-bit Arithmetic Left Shift
- Up to 8-bit Arithmetic Right Shift

E, SV and SL bits from MSW are affected by Left shifts, therefore if the saturation mechanism is enabled (MS), the behavior is similar to the one of the arithmetic unit. The carry flag C is also affected by left shifts.

Repeat unit

The MAC includes a repeat unit allowing the repetition of some co-processor instructions up to 2^{13} (8192) times. The repeat count may be specified either by an immediate value (up to 31 times) or by the content of the Repeat Count (bits 12 to 0) in the MAC Repeat Word (MRW). If the Repeat Count equals “N” the instruction will be executed “N+1” times. At each iteration of a cumulative instruction the Repeat Count is tested for zero. If it is zero the instruction is terminated else the Repeat Count is decremented and the instruction is repeated. During such a repeat sequence, the Repeat Flag in MRW is set until the last execution of the repeated instruction.

The syntax of repeated instructions is shown in the following examples:

```
1          Repeat #24 times
          CoMAC[IDX0+],[R0+]          ; repeated 24 times
```

In example 1, the instruction is repeated according to a 5-bit immediate value. The Repeat Count in MRW is automatically loaded with this value minus one (MRW=23).

```
1          MOV MRW, #00FFh           ; load MRW
          NOP                         ; instruction latency
          Repeat MRW times
          CoMACM [IDX1-],[R2+]       ; repeated 256 times
```

In this example, the instruction is repeated according to the Repeat Count in MRW. Notice that due to the pipeline processing at least one instruction should be inserted between the write of MRW and the next repeated instruction.

Repeat sequences may be interrupted. When an interrupt occurs during a repeat sequence, the sequence is stopped and the interrupt routine is executed. The repeat sequence resumes at the end of the interrupt routine. During the interrupt, MR remains set, indicating that a repeated instruction has been interrupted and the Repeat Count holds the number (minus 1)

of repetition that remains to complete the sequence. If the Repeat Unit is used in the interrupt routine, MRW must be saved by the user and restored before the end of the interrupt routine.

Note The Repeat Count should be used with caution. In this case MR should be written as 0. In general MR should not be set by the user otherwise correct instruction processing can not be guaranteed.

MAC interrupt

The MAC can generate an interrupt according to the value of the status flags C (carry), SV (overflow), E (extension) or SL (limit) of the MSW. The MAC interrupt is globally enabled when the MIE flag in MCW is set. When it is enabled the flags C, SV, E or SL can triggered a MAC interrupt when they are set provided that the corresponding mask flag CM, VM, EM or LM in MCW is also set. A MAC interrupt request set the MIR flag in MSW, this flag must be reset by the user during the interrupt routine otherwise the interrupt processing restarts when returning from the interrupt routine.

The MAC interrupt is implemented as a Class B hardware trap (trap number Ah - trap priority I). The associated Trap Flag in the TFR register is MACTRP, bit #6 of the TFR (Remember that this flag must also be reset by the user in the case of an MAC interrupt request).

As the MAC status flags are updated (or eventually written by software) during the Execute stage of the pipeline, the response time of a MAC interrupt request is 3 instruction cycles (see Figure 3). It is the number of instruction cycles required between the time the request is sent and the time the first instruction located at the interrupt vector location enters the pipeline. Note that the IP value stacked after a MAC interrupt does not point to the instruction that triggers the interrupt.

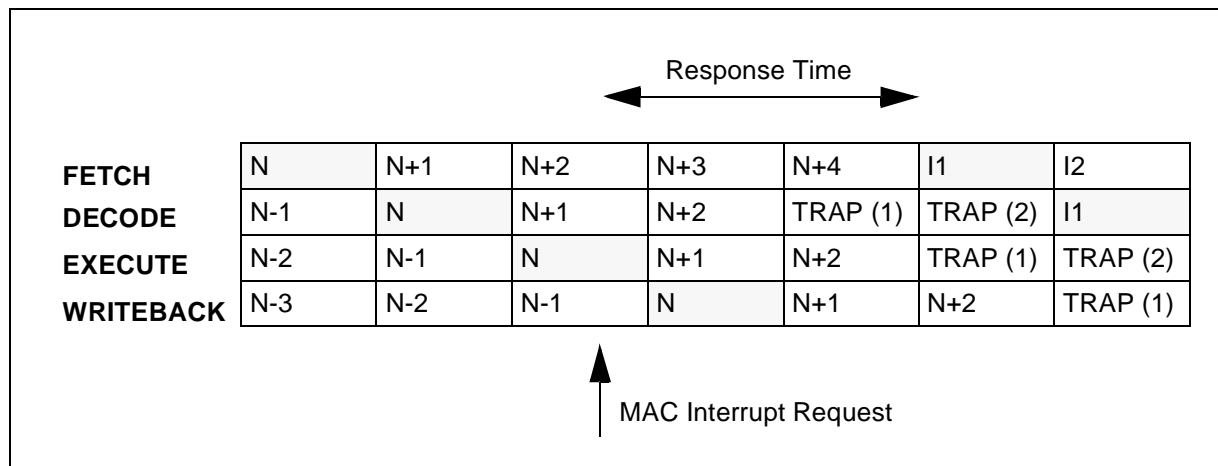

Figure 7 Pipeline diagram for MAC interrupt response time

Number representation & rounding

The MAC supports the two's-complement representation of binary numbers. In this format, the sign bit is the MSB of the binary word. This is set to zero for positive numbers and set to one for negative numbers. Unsigned numbers are supported only by multiply/multiply-accumulate instructions which specifies whether each operand is signed or unsigned.

In two's complement fractional format, the N-bit operand is represented using the 1.[N-1] format (1 signed bit, N-1 fractional bits). Such a format can represent numbers between -1 and $+1-2^{-[N-1]}$. This format is supported when MP of MCW is set.

The MAC implements 'two's complement rounding'. With this rounding type, one is added to the bit to the right of the rounding point (bit 15 of MAL), before truncation (MAL is cleared).

6 INTERRUPT AND TRAP FUNCTIONS

The architecture of the ST10R272L supports several mechanisms for fast and flexible response to the service requests that can be generated from various sources, internal or external to the microcontroller. Any of these interrupt requests can be programmed to be serviced, either by the Interrupt Controller or by the Peripheral Event Controller (PEC).

In a standard interrupt service, program execution is suspended and a branch to the interrupt service routine is performed. For a PEC service, just one cycle is 'stolen' from the current CPU activity. A PEC service is a single, byte or word data transfer between any two memory locations, with an additional increment of either the PEC source or the destination pointer. An individual PEC transfer counter is decremented for each PEC service, except in the continuous transfer mode. When this counter reaches zero, a standard interrupt is performed to the corresponding source-related vector location. PEC services are very well suited, for example, to the transmission or reception of blocks of data. The ST10R272L has 8 PEC channels, each of which offers fast interrupt-driven data transfer capabilities.

A separate control register which contains an interrupt request flag, an interrupt enable flag and an interrupt priority bitfield, exists for each of the possible interrupt sources. Via its related register, each source can be programmed to one of sixteen interrupt priority levels. Once having been accepted by the CPU, an interrupt service can only be interrupted by a higher priority service request. For standard interrupt processing, each of the possible interrupt sources has a dedicated vector location.

Fast external interrupt inputs are provided to service external interrupts with high precision requirements. These fast interrupt inputs, feature programmable edge detection (rising edge, falling edge or both edges).

Software interrupts are supported by means of the 'TRAP' instruction in combination with an individual trap (interrupt) number.

6.1 Interrupt Sources

Source of Interrupt or PEC Service Request	Request Flag	Enable Flag	Interrupt Vector	Vector Location	Trap Number
External Interrupt 0	CC8IR	CC8IE	CC8INT	60h	18h
External Interrupt 1	CC9IR	CC9IE	CC9INT	64h	19h
External Interrupt 2	CC10IR	CC10IE	CC10INT	68h	1Ah
External Interrupt 3	CC11IR	CC11IE	CC11INT	6Ch	1Bh
GPT1 Timer 2	T2IR	T2IE	T2INT	88h	22h
GPT1 Timer 3	T3IR	T3IE	T3INT	8Ch	23h
GPT1 Timer 4	T4IR	T4IE	T4INT	90h	24h
GPT2 Timer 5	T5IR	T5IE	T5INT	94h	25h
GPT2 Timer 6	T6IR	T6IE	T6INT	98h	26h
GPT2 CAPREL Register	CRIR	CRIE	CRINT	9Ch	27h
ASC0 Transmit	S0TIR	S0TIE	S0TINT	A8h	2Ah
ASC0 Transmit Buffer	S0TBIR	S0TBIE	S0TBINT	11Ch	47h
ASC0 Receive	S0RIR	S0RIE	S0RINT	ACh	2Bh
ASC0 Error	S0EIR	S0EIE	S0EINT	B0h	2Ch
PWM Channel 3	PWMIR	PWMIE	PWMINT	FCh	3Fh
SSP Interrupt	XP1IR	XP1IE	XP1INT	104h	41h
PLL Unlock	XP3IR	XP3IE	XP3INT	10Ch	43h

Table 5 List of possible interrupt sources, flags, vector and trap numbers

6.2 Hardware Traps

Exceptions or error conditions that arise during run-time are called Hardware Traps. Hardware traps cause immediate non-maskable system reaction similar to a standard interrupt service (branching to a dedicated vector table location). The occurrence of a hardware trap is additionally signified by an individual bit in the trap flag register (TFR). Except when another higher prioritized trap service is in progress, a hardware trap will interrupt any actual program execution. In turn, hardware trap services can not normally be interrupted by standard or PEC interrupts. The following table shows all of the possible exceptions or error conditions that can arise during run-time:

Exception Condition	Trap Flag	Trap Vector	Vector Location	Trap Number	Trap Priority
Reset Functions:					
Hardware Reset		RESET	00'0000h	00h	III
Software Reset		RESET	00'0000h	00h	III
Watchdog Timer Overflow		RESET	00'0000h	00h	III
Class A Hardware Traps:					
Non-Maskable Interrupt	NMI	NMITRAP	00'0008h	02h	II
Stack Overflow	STKOF	STOTRAP	00'0010h	04h	II
Stack Underflow	STKUF	STUTRAP	00'0018h	06h	II
Class B Hardware Traps:					
Undefined opcode	UNDOPC	BTRAP	00'0028h	0Ah	I
Protected instruction fault	PRTFLT	BTRAP	00'0028h	0Ah	I
Illegal word operand access	ILLOPA	BTRAP	00'0028h	0Ah	I
Illegal instruction access	ILLINA	BTRAP	00'0028h	0Ah	I
Illegal external bus access	ILLBUS	BTRAP	00'0028h	0Ah	I
MAC trap	MACTRP	BTRAP	00'0028h	0Ah	I
Reserved			[2Ch – 3Ch]	[0Bh – 0Fh]	
Software Traps					
TRAP Instruction			Any [00'0000h – 00'01FCh] steps of 4h	Any [00h – 7Fh]	Current CPU Priority

Table 6 Exceptions or error conditions

7 PARALLEL PORTS

The ST10R272L provides up to 77 I/O lines organized into 7 input/output ports and one input port. All port lines are bit-addressable, and all input/output lines are individually (bit-wise) programmable as inputs or outputs by direction registers. The I/O ports are true bidirectional ports which are switched to high impedance state when configured as inputs. The output drivers of three I/O ports can be configured (pin by pin) for push/pull operation or open-drain operation by control registers. During the internal reset, all port pins are configured as inputs.

All port lines have programmable alternate input or output functions associated with them. PORT0 and PORT1 may be used as address and data lines when accessing external memory, while Port 4 outputs the additional segment address bits A23/19/17...A16 in systems where segmentation is enabled to access more than 64 KBytes of memory. Port 6 provides optional bus arbitration signals ($\overline{\text{BREQ}}$, $\overline{\text{HLDA}}$, $\overline{\text{HOLD}}$) and chip select signals. Port 3 includes alternate functions of timers, serial interfaces, the optional bus control signal $\overline{\text{BHE}}$ and the system clock output (CLKOUT). Port 5 is used for timer control signals. Port 2 lines can be used as fast external interrupt lines. Port 7 includes alternate function for the PWM signal. All port lines that are not used for these alternate functions may be used as general purpose I/O lines.

8 EXTERNAL BUS CONTROLLER

All external memory accesses are performed by the on-chip External Bus Controller which can be programmed either to single chip mode when no external memory is required, or to the following external memory access modes:

16-bit data, demultiplexed	16-/18-/20-/24-bit addresses
16-bit data, multiplexed	16-/18-/20-/24-bit addresses
8-bit data, multiplexed	16-/18-/20-/24-bit addresses
8-bit data, demultiplexed	16-/18-/20-/24-bit addresses

In the demultiplexed bus modes, addresses are output on PORT1 and data is input/output on PORT0/P0L, respectively. In the multiplexed bus modes both addresses and data use PORT0 for input/output.

Memory cycle time, memory tri-state time, length of ALE and read write delay are programmable so that a wide range of different memory types and external peripherals can be used. Up to 4 independent address windows can be defined (via ADDRSELx / BUSCONx register pairs) to access different resources with different bus characteristics. These address windows are arranged hierarchically where BUSCON4 overrides BUSCON3 etc. All accesses to locations not covered by these 4 address windows are controlled by BUSCON0. Up to 5 external $\overline{\text{CS}}$ signals (4 windows plus default) can be generated to reduce external glue logic. Access to very slow memories is supported by the READY function.

A $\overline{\text{HOLD}}/\overline{\text{HLDA}}$ protocol is available for bus arbitration so that external resources can be shared with other bus masters. In slave mode, the slave controller can be connected to another master controller without glue logic. For applications which require less than 16 MBytes

of external memory space, the address space can be restricted to 1 MByte, 256 KByte or to 64 KByte.

9 PWM MODULE

A 1-channel Pulse Width Modulation (PWM) Module operates on channel 3. The pulse width modulation module can generate up to four PWM output signals using edge-aligned or centre-aligned PWM. In addition, the PWM module can generate PWM burst signals and single shot outputs. The table below shows the PWM frequencies for different resolutions. The level of the output signals is selectable and the PWM module can generate interrupt requests.

Mode 0 edge aligned	Resolution	8-bit	10-bit	12-bit	14-bit	16-bit
CPU clock/1	20ns	195.3 KHz	48.83KHz	12.21KHz	3.052KHz	762.9Hz
CPU clock/64	1.28ns	3.052KHz	762.9Hz	190.7Hz	47.68Hz	11.92Hz
Mode 1 center aligned	Resolution	8-bit	10-bit	12-bit	14-bit	16-bit
CPU clock/1	20ns	97.66KHz	24.41KHz	6.104KHz	1.525KHz	381.5Hz
CPU clock/64	1.28ns	1.525Hz	381.5 Hz	95.37Hz	23.84Hz	0Hz

Table 7 PWM unit frequencies and resolution at 50MHz CPU clock

10 GENERAL PURPOSE TIMERS

The GPTs are flexible multifunctional timer/counters used for time-related tasks such as event timing and counting, pulse width and duty cycle measurements, pulse generation or pulse multiplication. The GPT unit contains five 16-bit timers, organized in two separate modules, GPT1 and GPT2. Each timer in each module may operate independently in a number of different modes, or may be concatenated with another timer of the same module.

10.1 GPT1

Each of the three timers T2, T3, T4 of the GPT1 module can be configured individually for one of four basic modes of operation: **timer, gated timer, counter mode and incremental interface mode**. In timer mode, the input clock for a timer is derived from the CPU clock, divided by a programmable prescaler. In counter mode, the timer is clocked in reference to external events. Pulse width or duty cycle measurement is supported in gated timer mode where the operation of a timer is controlled by the 'gate' level on an external input pin. For these purposes, each timer has one associated port pin (TxIN) which serves as gate or clock input. Table 8 GPT1 timer input frequencies, resolution and periods lists the timer input frequencies, resolution and periods for each pre-scaler option at 50MHz CPU clock. This also applies to the Gated Timer Mode of T3 and to the auxiliary timers T2 and T4 in Timer and Gated Timer Mode

The count direction (up/down) for each timer is programmable by software or may additionally be altered dynamically by an external signal on a port pin (TxEUD).

In Incremental Interface Mode, the GPT1 timers (T2, T3, T4) can be directly connected to the incremental position sensor signals A and B by their respective inputs TxIN and TxEUD. Direction and count signals are internally derived from these two input signals so that the contents of the respective timer Tx corresponds to the sensor position. The third position sensor signal TOP0 can be connected to an interrupt input.

Timer T3 has output toggle latches (TxOTL) which changes state on each timer over-flow/underflow. The state of this latch may be output on port pins (TxOUT) e. g. for time out monitoring of external hardware components, or may be used internally to clock timers T2 and T4 for measuring long time periods with high resolution.

In addition to their basic operating modes, timers T2 and T4 may be configured as reload or capture registers for timer T3. When used as capture or reload registers, timers T2 and T4 are stopped. The contents of timer T3 is captured into T2 or T4 in response to a signal at their associated input pins (TxIN). Timer T3 is reloaded with the contents of T2 or T4 triggered either by an external signal or by a selectable state transition of its toggle latch T3OTL. When both T2 and T4 are configured to alternately reload T3 on opposite state transitions of T3OTL with the low and high times of a PWM signal, this signal can be constantly generated without software intervention.

ST10R272L - GENERAL PURPOSE TIMERS

F _{CPU} =50MHz	Timer input selection							
	000b	001b	010b	011b	100b	101b	110b	111b
Prescaler Factor	8	16	32	64	128	256	512	1024
Input Frequency	6.25 MHz	3.125 MHz	1.5625 MHz	781 KHz	391 KHz	195 KHz	97.5 KHz	48.83 KHz
Resolution	160ns	320ns	640ns	1.28 us	2.56 us	5.12 us	10.24 us	20.48 us
Period	10.49ms	20.97ms	41.94ms	83.88ms	168ms	336ms	672ms	1.342s

Table 8 GPT1 timer input frequencies, resolution and periods

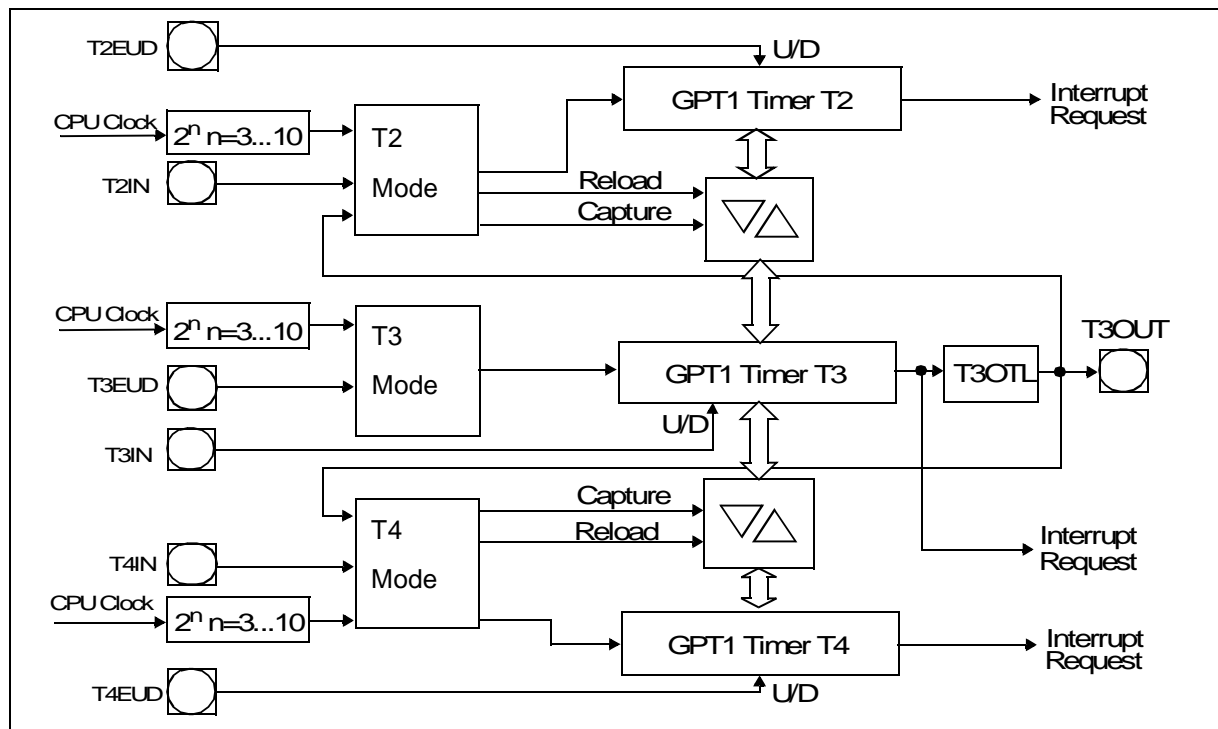

Figure 8 GPT1 block diagram

10.2 GPT2

The GPT2 module provides precise event control and time measurement. It includes two timers (T5, T6) and a capture/reload register (CAPREL). Both timers can be clocked with an input clock derived from the CPU clock via a programmable prescaler or with external signals. The count direction (up/down) for each timer is programmable by software or altered dynamically by an external signal on a port pin (TxEUD). Concatenation of the timers is supported by the output toggle latch (T6OTL) of timer T6, which changes its state on each timer overflow/underflow.

The state of T6OTL may be used to clock timer T5, or may be output on a port pin T6OUT. The overflows/underflows of timer T6 reload the CAPREL register. The CAPREL register captures the contents of T5 based on an external signal transition on the corresponding port pin (CAPIN), and timer T5 may optionally be cleared after the capture procedure. This allows absolute time differences to be measured or pulse multiplication to be performed without software overhead.

F_{CPU}=50MHz	Timer input selection							
	000b	001b	010b	011b	100b	101b	110b	111b
Prescaler Factor	4	8	16	32	64	128	256	512
Input Frequency	12.5 MHz	6.25 MHz	3.125 MHz	1.563 MHz	781 KHz	391 KHz	195 KHz	97.6 KHz
Resolution	80ns	160ns	320ns	640ns	1.28 us	2.56 us	5.12 us	10.24 us
Period	5.24ms	10.49ms	20.97ms	41.94ms	83.88ms	167.7ms	335.5ms	671ms

Table 9 GPT2 timer input frequencies, resolution and periods

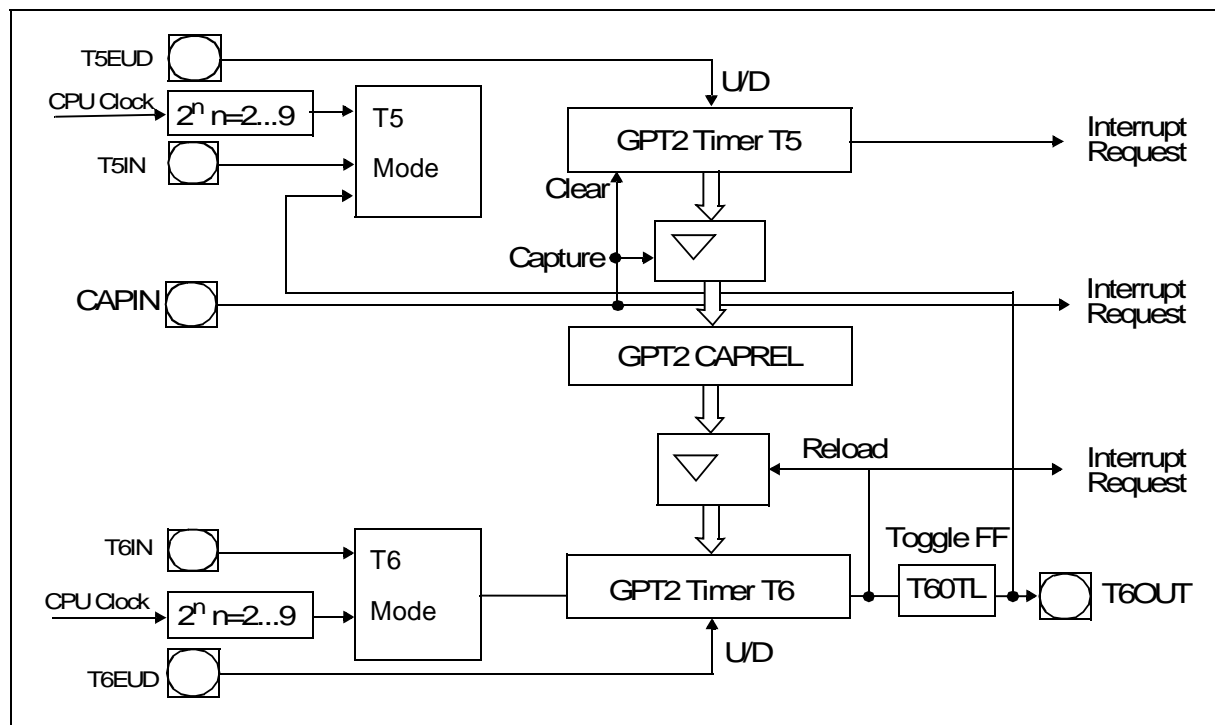

Figure 9 GPT2 block diagram

11 SERIAL CHANNELS

Serial communication with other microcontrollers, processors, terminals or external peripheral components is provided by two serial interfaces with different functionality, an Asynchronous/Synchronous Serial Channel (ASC0) and a Synchronous Serial Port (SSP).

ASC0

A dedicated baud rate generator sets up standard baud rates without oscillator tuning. 3 separate interrupt vectors are provided for transmission, reception, and erroneous reception. In asynchronous mode, 8- or 9-bit data frames are transmitted or received, preceded by a start bit and terminated by one or two stop bits. For multiprocessor communication, a mechanism to distinguish address from data bytes has been included (8-bit data + wake up bit mode).

In synchronous mode, the ASC0 transmits or receives bytes (8 bits) synchronously to a shift clock which is generated by the ASC0. The ASC0 always shifts the LSB first. A loop back option is available for testing purposes.

A number of optional hardware error detection capabilities have been included to increase the reliability of data transfers. A parity bit can be generated automatically on transmission, or checked on reception. Framing error detection recognizes data frames with missing stop bits. An overrun error is generated if the last character received was not read out of the receive buffer register at the time the reception of a new character is complete. The table below lists

various commonly used baud rates together with the required reload values and the deviation errors compared to the intended baudrate.

S0BRS = '0', f _{CPU} = 50MHz			S0BRS = '1', f _{CPU} = 50MHz		
Baud Rate (Baud)	Deviation Error	Reload Value	Baud Rate (Baud)	Deviation Error	Reload Value
1562500	0.0% / 0.0%	0000 _H / 0000 _H	1041666	0.0% / 0.0%	0000 _H / 0000 _H
56000	+3.3% / -0.4%	001A _H / 001B _H	56000	+3.3% / -2.1%	0011 _H / 0012 _H
38400	+1.7% / -0.8%	0027 _H / 0028 _H	38400	+0.5% / -3.1%	001A _H / 001B _H
19200	+0.5% / -0.8%	0050 _H / 0051 _H	19200	+0.5% / -1.4%	0035 _H / 0036 _H
9600	+0.5% / -0.1%	00A1 _H / 00A2 _H	9600	+0.5% / -0.5%	006B _H / 006C _H
4800	+0.2% / -0.1%	0144 _H / 0145 _H	4800	0.0% / -0.5%	00D8 _H / 00D9 _H
2400	0.0% / -0.1%	028A _H / 028B _H	2400	0.0% / -0.2%	01B1 _H / 01B2 _H
1200	0.0% / -0.1%	0515 _H / 0516 _H	1200	0.0% / -0.1%	0363 _H / 0364 _H
600	0.0% / 0.0%	0A2B _H / 0A2C _H	600	0.0% / -0.1%	06C7 _H / 06C8 _H
190	+0.4% / +0.4%	1FFF _H / 1FFF _H	75	0.0% / 0.0%	363F _H / 3640 _H
			127	+0.1% / +0.1%	1FFF _H / 1FFF _H

Table 10 Commonly used baud rates, required reload values and deviation errors

SSP transmits 1...3 bytes or receives 1 byte after sending 1...3 bytes synchronously to a shift clock which is generated by the SSP. The SSP can start shifting with the LSB or with the MSB and is used to select shifting and latching clock edges, and clock polarity. Up to two chip select lines may be activated in order to direct data transfers to one or both of two peripheral devices.

When the SSP is enabled, the four upper pins of Port4 can not be used as general purpose IO. Note that the segment address selection done via the system start-up configuration during reset has priority and overrides the SSP functions on these pins.

SSPCKS Value		Synchronous baud rate
000	SSP clock = CPU clock divided by 2	25 MBit/s
001	SSP clock = CPU clock divided by 4	12.5 MBit/s
010	SSP clock = CPU clock divided by 8	6.25 MBit/s

Table 11 Synchronous baud rate and SSPCKS reload values

SSPCKS Value		Synchronous baud rate
011	SSP clock = CPU clock divided by 16	3.13 MBit/s
100	SSP clock = CPU clock divided by 32	1.56 MBit/s
101	SSP clock = CPU clock divided by 64	781 KBit/s
110	SSP clock = CPU clock divided by 128	391 KBit/s
111	SSP clock = CPU clock divided by 256	195 KBit/s

Table 11 Synchronous baud rate and SSPCKS reload values

12 WATCHDOG TIMER

The Watchdog Timer is a fail-safe mechanism which limits the malfunction time of the controller. The Watchdog Timer is always enabled after device reset and can only be disabled in the time interval until the EINIT (end of initialization) instruction has been executed. In this way, the chip's start-up procedure is always monitored. The software must be designed to service the Watchdog Timer before it overflows. If, due to hardware or software related failures, the software fails to maintain the Watchdog Timer, it will overflow generating an internal hardware reset and pulling the $\overline{\text{RSTOUT}}$ pin low to reset external hardware components.

The Watchdog Timer is a 16-bit timer, clocked with the system clock divided either by 2 or by 128. The high byte of the Watchdog Timer register can be set to a pre-specified reload value (stored in WDTREL) in order to allow further variation of the monitored time interval. Each time it is serviced by the application software, the high byte of the Watchdog Timer is reloaded. The table below shows the watchdog time range which for a 50MHz CPU clock rounded to 3 significant figures.

Reload value in WDTREL	Prescaler for f_{CPU}	
	2 (WDTIN = '0')	128 (WDTIN = '1')
FF _H	10.24 μs	655 μs
00 _H	2.62 ms	168 ms

Table 12 Watchdog timer range

13 SYSTEM RESET

The following type of reset are implemented on the ST10R272L:

Asynchronous hardware reset: Asynchronous reset does not require a stabilized clock signal on XTAL1 as it is not internally resynchronized, it resets the microcontroller into its default reset state. Asynchronous reset is required on chip power-up and can be used during catastrophic situations. The rising edge of the RSTIN pin is internally resynchronized before exiting the reset condition, therefore, only the entry to hardware reset is asynchronous.

Synchronous hardware reset (warm reset): A warm synchronous hardware reset is triggered when the reset input signal $\overline{\text{RSTIN}}$ is latched low and Vpp pin is high. The I/Os are immediately (asynchronously) set in high impedance, $\overline{\text{RSTOUT}}$ is driven low. After $\overline{\text{RSTIN}}$ negation is detected, a short transition period elapses, during which pending internal hold states are cancelled and any current internal access cycles are completed, external bus cycles are aborted. Then, the internal reset sequence is active for 1024 TCL (512 CPU clock cycles). During this reset sequence, if bit BDRSTEN was previously set by software (bit 3 in SYSCON register), $\overline{\text{RSTIN}}$ pin is driven low and internal reset signal is asserted to reset the microcontroller in its default state. Note that after all reset sequence, bit BDRSTEN is cleared. After the reset sequence has been completed, the $\overline{\text{RSTIN}}$ input is sampled. When the reset input signal is active at that time the internal reset condition is prolonged until $\overline{\text{RSTIN}}$ becomes inactive.

Software reset: The reset sequence can be triggered at any time by the protected instruction SRST (software reset). This instruction can be executed deliberately within a program, e.g. to leave bootstrap loader mode, or on a hardware trap that reveals a system failure. As for a synchronous hardware reset, if bit BDRSTEN was previously set by software (bit 3 in SYSCON register), the reset sequence lasts 1024 TCL (512 CPU clock cycles), and drives the $\overline{\text{RSTIN}}$ pin low.

Watchdog timer reset: When the watchdog timer is not disabled during the initialization or serviced regularly during program execution it will overflow and trigger the reset sequence. Unlike hardware and software resets, the watchdog reset completes a running external bus cycle if this bus cycle does not use $\overline{\text{READY}}$, or if $\overline{\text{READY}}$ is sampled active (low) after the programmed waitstates. When $\overline{\text{READY}}$ is sampled inactive (high) after the programmed waitstates the running external bus cycle is aborted. Then the internal reset sequence is started. The watchdog reset cannot occur while the ST10R272L is in bootstrap loader mode.

Bidirectional reset: The bidirectional reset is activated by setting bit BDRSTEN (bit 3 in SYSCON register). This reset makes the watchdog timer reset and software reset externally visible. It is active for the duration of an internal reset sequences caused by a watchdog timer reset and software reset. Therefore, the bidirectional reset transforms an internal watchdog timer reset or software reset into an external hardware reset with a minimum duration of 1024 TCL.

14 POWER REDUCTION MODES

Two different power reduction modes with different levels of power reduction can be entered under software control.

In **Idle mode** the CPU is stopped, while the peripherals continue their operation. Idle mode can be terminated by any reset or interrupt request.

In **Power Down mode** both the CPU and the peripherals are stopped. Power Down mode can now be configured by software in order to be terminated only by a hardware reset or by an external interrupt source on fast external interrupt pins.

All external bus actions are completed before Idle or Power Down mode is entered. However, Idle or Power Down mode is **not** entered if READY is enabled, but has not been activated (driven low for negative polarity, or driven high for positive polarity) during the last bus access.

15 SPECIAL FUNCTION REGISTERS

The following table lists all ST10R272L SFRs in alphabetical order.

Bit-addressable SFRs are marked with the letter “b” in column “Name”. SFRs within the Extended SFR-Space (ESFRs) are marked with the letter “E” in column “Physical Address”.

An SFR can be specified by its individual mnemonic name. Depending on the selected addressing mode, an SFR can be accessed by its physical address (using the Data Page Pointers), or by its short 8-bit address (without using the Data Page Pointers).

Name	Physical Address	8-Bit Address	Description	Reset Value
ADDRSEL1	FE18h	0Ch	Address Select Register 1	0000h
ADDRSEL2	FE1Ah	0Dh	Address Select Register 2	0000h
ADDRSEL3	FE1Ch	0Eh	Address Select Register 3	0000h
ADDRSEL4	FE1Eh	0Fh	Address Select Register 4	0000h
BUSCON0 b	FF0Ch	86h	Bus Configuration Register 0	0XX0h
BUSCON1 b	FF14h	8Ah	Bus Configuration Register 1	0000h
BUSCON2 b	FF16h	8Bh	Bus Configuration Register 2	0000h
BUSCON3 b	FF18h	8Ch	Bus Configuration Register 3	0000h
BUSCON4 b	FF1Ah	8Dh	Bus Configuration Register 4	0000h
CAPREL	FE4Ah	25h	GPT2 Capture/Reload Register	0000h
CC8IC b	FF88h	C4h	EX0IN Interrupt Control Register	0000h

Table 13 Special functional registers

ST10R272L - SPECIAL FUNCTION REGISTERS

Name	Physical Address	8-Bit Address	Description	Reset Value
CC9IC	b FF8Ah	C5h	EX1IN Interrupt Control Register	0000h
CC10IC	b FF8Ch	C6h	EX2IN Interrupt Control Register	0000h
CC11IC	b FF8Eh	C7h	EX3IN Interrupt Control Register	0000h
CP	FE10h	08h	CPU Context Pointer Register	FC00h
CRIC	b FF6Ah	B5h	GPT2 CAPREL Interrupt Control Register	0000h
CSP	FE08h	04h	CPU Code Segment Pointer Register (read only)	0000h
DP0L	b F100h E	80h	P0L Direction Control Register	00h
DP0H	b F102h E	81h	P0h Direction Control Register	00h
DP1L	b F104h E	82h	P1L Direction Control Register	00h
DP1H	b F106h E	83h	P1h Direction Control Register	00h
DP2	b FFC2h	E1h	Port 2 Direction Control Register	-0--h
DP3	b FFC6h	E3h	Port 3 Direction Control Register	0000h
DP4	b FFCAh	E5h	Port 4 Direction Control Register	00h
DP6	b FFCEh	E7h	Port 6 Direction Control Register	00h
DP7	b FFD2h	E9h	Port 7 Direction Control Register	-0h
DPP0	FE00h	00h	CPU Data Page Pointer 0 Register (10 bits)	0000h
DPP1	FE02h	01h	CPU Data Page Pointer 1 Register (10 bits)	0001h
DPP2	FE04h	02h	CPU Data Page Pointer 2 Register (10 bits)	0002h
DPP3	FE06h	03h	CPU Data Page Pointer 3 Register (10 bits)	0003h
EBUSCON	b F10Eh E	87H	Extended BUSCON register	0000h
EXICON	b F1C0h E	E0h	External Interrupt Control Register	0000h
IDCHIP	F07Ch E	3Eh	Device Identifier Register	1101h
IDMANUF	F07Eh E	3Fh	Manufacturer/Process Identifier Register	0201h
IDMEM	F07Ah E	3Dh	On-chip Memory Identifier Register	0000h
IDPROG	F078h E	3Ch	Programming Voltage Identifier Register	0000h
IDX0	b FF08h	84h	MAC Unit Address Pointer 0	0000h

Table 13 Special functional registers

ST10R272L - SPECIAL FUNCTION REGISTERS

Name	Physical Address	8-Bit Address	Description	Reset Value
IDX1	b FF0Ah	85h	MAC Unit Address Pointer 1	0000h
MAH	FE5Eh	2Fh	MAC Unit Accumulator - High Word	0000h
MAL	FE5Ch	2Eh	MAC Unit Accumulator - Low Word	0000h
MCW	FFDCh	EEh	MAC Unit Control Word	0000h
MDC	b FF0Eh	87h	CPU Multiply Divide Control Register	0000h
MDH	FE0Ch	06h	CPU Multiply Divide Register – High Word	0000h
MDL	FE0Eh	07h	CPU Multiply Divide Register – Low Word	0000h
MRW	b FFDAh	EDh	MAC Unit Repeat Word	0000h
MSW	b FFDEh	EFh	MAC Unit Status Word	0200h
ODP2	b F1C2h E	E1h	Port 2 Open Drain Control Register	-0--h
ODP3	b F1C6h E	E3h	Port 3 Open Drain Control Register	0000h
ODP6	b F1CEh E	E7h	Port 6 Open Drain Control Register	00h
ODP7	b F1D2h E	E9h	Port 7 Open Drain Control Register	-0h
ONES	FF1Eh	8Fh	Constant Value 1's Register (read only)	FFFFh
P0L	b FF00h	80h	Port 0 Low Register (Lower half of PORT0)	00h
P0H	b FF02h	81h	Port 0 High Register (Upper half of PORT0)	00h
P1L	b FF04h	82h	Port 1 Low Register (Lower half of PORT1)	00h
P1H	b FF06h	83h	Port 1 High Register (Upper half of PORT1)	00h
P2	b FFC0h	E0h	Port 2 Register (4 bits)	-0--h
P3	b FFC4h	E2h	Port 3 Register	0000h
P4	b FFC8h	E4h	Port 4 Register (8 bits)	00h
P5	b FFA2h	D1h	Port 5 Register (read only)	XXXXh
P6	b FFCCh	E6h	Port 6 Register (8 bits)	00h
P7	b FFD0h	E8h	Port 7 Register (4 bits)	-0h
PECC0	FEC0h	60h	PEC Channel 0 Control Register	0000h
PECC1	FEC2h	61h	PEC Channel 1 Control Register	0000h

Table 13 Special functional registers

ST10R272L - SPECIAL FUNCTION REGISTERS

Name	Physical Address	8-Bit Address	Description	Reset Value
PECC2	FEC4h	62h	PEC Channel 2 Control Register	0000h
PECC3	FEC6h	63h	PEC Channel 3 Control Register	0000h
PECC4	FEC8h	64h	PEC Channel 4 Control Register	0000h
PECC5	FECAh	65h	PEC Channel 5 Control Register	0000h
PECC6	FECCh	66h	PEC Channel 6 Control Register	0000h
PECC7	FECEh	67h	PEC Channel 7 Control Register	0000h
PP3	F03Eh E	1Fh	PWM Module Period Register 3	0000h
PSW b	FF10h	88h	CPU Program Status Word	0000h
PW3	FE36h	1Bh	PWM Module Pulse Width Register 3	0000h
PWMCON0 b	FF30h	98h	PWM Module Control Register 0	0000h
PWMCON1 b	FF32h	99h	PWM Module Control Register 1	0000h
PWMIC b	F17Eh E	BFh	PWM Module Interrupt Control Register	0000h
QR0	F004h E	02h	MAC Unit Offset Register R0 (8 bits)	00h
QR1	F006h E	03h	MAC Unit Offset Register R1 (8 bits)	00h
QX0	F000h E	00h	MAC Unit Offset Register X0 (8 bits)	00h
QX1	F002h E	01h	MAC Unit Offset Register X1 (8 bits)	00h
RP0H b	F108h E	84h	System Start-up Configuration Register (Rd. only)	XXh
S0BG	FEB4h	5Ah	Serial Channel 0 baud rate generator reload reg	0000h
S0CON b	FFB0h	D8h	Serial Channel 0 Control Register	0000h
S0EIC b	FF70h	B8h	Serial Channel 0 Error Interrupt Control Register	0000h
S0RBUF	FEB2h	59h	Serial Channel 0 receive buffer reg. (rd only)	XXh
S0RIC b	FF6Eh	B7h	Serial Channel 0 Receive Interrupt Control Reg.	0000h
S0TBIC b	F19Ch E	CEh	Serial Channel 0 transmit buffer interrupt control reg	0000h
S0TBUF	FEB0h	58h	Serial Channel 0 transmit buffer register (wr only)	00h
S0TIC b	FF6Ch	B6h	Serial Channel 0 Transmit Interrupt Control Register	0000h

Table 13 Special functional registers

ST10R272L - SPECIAL FUNCTION REGISTERS

Name	Physical Address	8-Bit Address	Description	Reset Value
SP	FE12h	09h	CPU System Stack Pointer Register	FC00h
SSPCON0	EF00h X	---	SSP Control Register 0	0000h
SSPCON1	EF02h X	---	SSP Control Register 1	0000h
SSPRTB	EF04h X	---	SSP Receive/Transmit Buffer	XXXXh
SSPTBH	EF06h X	---	SSP Transmit Buffer High	XXXXh
STKOV	FE14h	0Ah	CPU Stack Overflow Pointer Register	FA00h
STKUN	FE16h	0Bh	CPU Stack Underflow Pointer Register	FC00h
SYSCON b	FF12h	89h	CPU System Configuration Register	0xx0h ¹⁾
T2	FE40h	20h	GPT1 Timer 2 Register	0000h
T2CON b	FF40h	A0h	GPT1 Timer 2 Control Register	0000h
T2IC b	FF60h	B0h	GPT1 Timer 2 Interrupt Control Register	0000h
T3	FE42h	21h	GPT1 Timer 3 Register	0000h
T3CON b	FF42h	A1h	GPT1 Timer 3 Control Register	0000h
T3IC b	FF62h	B1h	GPT1 Timer 3 Interrupt Control Register	0000h
T4	FE44h	22h	GPT1 Timer 4 Register	0000h
T4CON b	FF44h	A2h	GPT1 Timer 4 Control Register	0000h
T4IC b	FF64h	B2h	GPT1 Timer 4 Interrupt Control Register	0000h
T5	FE46h	23h	GPT2 Timer 5 Register	0000h
T5CON b	FF46h	A3h	GPT2 Timer 5 Control Register	0000h
T5IC b	FF66h	B3h	GPT2 Timer 5 Interrupt Control Register	0000h
T6	FE48h	24h	GPT2 Timer 6 Register	0000h
T6CON b	FF48h	A4h	GPT2 Timer 6 Control Register	0000h
T6IC b	FF68h	B4h	GPT2 Timer 6 Interrupt Control Register	0000h
TFR b	FFACh	D6h	Trap Flag Register	0000h
WDT	FEAEh	57h	Watchdog Timer Register (read only)	0000h
WDTCON	FFAEh	D7h	Watchdog Timer Control Register	000xh ²⁾

Table 13 Special functional registers

ST10R272L - SPECIAL FUNCTION REGISTERS

Name		Physical Address	8-Bit Address	Description	Reset Value
XP1IC	b	F18Eh E	C7h	SSP Interrupt Control Register	0000h
XP3IC	b	F19Eh E	CFh	PLL unlock Interrupt Control Register	0000h
ZEROS	b	FF1Ch	8Eh	Constant Value 0's Register (read only)	0000h

Table 13 Special functional registers

Note 1. The system configuration is selected during reset.

Note 2. Bit WDTR indicates a watchdog timer triggered reset.

16 ELECTRICAL CHARACTERISTICS

16.1 Absolute Maximum Ratings

- Ambient temperature under bias (T_A): -40 to +85 °C
- Storage temperature (T_{ST}): - 65 to +150 °C
- Voltage on V_{DD} pins with respect to ground (V_{SS}): - 0.5 to +4.0 V
- Voltage on any pin with respect to ground (V_{SS}): -0.5 to $V_{DD} + 0.5$ V
- Voltage on any 5V tolerant pin with respect to ground (V_{SS}): -0.5 to 5.5 V
- Voltage on any 5V fail-safe pin with respect to ground (V_{SS}): -0.5 to 5.5 V
- Input current on any pin during overload condition: -10 to +10 mA
- Absolute sum of all input currents during overload condition: |100 mA|
- Power dissipation: 1.0 W

Note Stresses above those listed under “Absolute Maximum Ratings” may cause permanent damage to the device. This is a stress rating only and functional operation of the device at these or any other conditions above those indicated in the operational sections of this specification is not guaranteed. Exposure to absolute maximum rating conditions for extended periods may affect device reliability. During overload conditions ($V_{IN} > V_{DD}$ or $V_{IN} < V_{SS}$) the voltage on pins with respect to ground (V_{SS}) must not exceed the values defined by the Absolute Maximum Ratings.

The parameters listed in this section represent both the ST10R272L controller characteristics and the system requirements. To aid parameters interpretation in design evaluation, the a symbol column is marked:

CC for **C**ontroller **C**haracteristics: The ST10R272L logic provides signals with the respective timing characteristics.

SR for **S**ystem Requirement: The external system must provide signals with the respective timing characteristics to the ST10R272L.

Remarks on 5 volt tolerant (5T) and 5 volt fail-safe (5S) pins

The 5V tolerant input and output pins can sustain an absolute maximum external voltage of 5.5V.

However, signals on unterminated bus lines might have overshoot above 5.5V, presenting latchup and hot carrier risks. While these risks are under evaluation, observe the following security recommendations:

- Maximum peak voltage on 5V tolerant pin with respect to ground (V_{SS})= +6 V
- If the ringing of the external signal exceeds 6V, then clip the signal to the 5V supply.

Power supply failure condition

The power supply failure condition is a state where the chip is NOT supplied but is connected to active signal lines. There are several cases:

- 3.3V external lines on 3.3V (3T) pin on the non powered chip:NOT Acceptable
- 3.3V external lines on 5V tolerant (5T) pin on the non powered chip: Acceptable
The 5V tolerant buffer do not leak: external signals not altered. No reliability problem.
- 3.3V external lines on 5V fail-safe (5S) pin on the non powered chip: Acceptable
The 5V tolerant buffer do not leak: external signals not altered. No reliability problem.
- 5.5V external lines on 5V tolerant (5T) pin on the non powered chip: Acceptable
For VERY SHORT times only: the buffers do not leak (external signals not altered) but there is a fast degradation of the gate oxides in the buffers. The total maximum time under this stress condition is 2 days. This limits this configuration to short power-up/down sequences. For 10 year life time, the maximum duty factor is 1/1800 allowing e.g. a maximum stress duration of 48 seconds per day.
- 5.5V external lines on 5V fail-safe (5S) pin on the non powered chip: Acceptable
- 6V transient signals on 5V tolerant (5T) pin on the non powered chip: ...NOT Acceptable
- 6V transient signals on 5V fail-safe (5S) pin on the non powered chip:..... Acceptable

ST10R272L - ELECTRICAL CHARACTERISTICS

16.2 DC Characteristics

$$V_{DD} = 3.3V \pm 0.3V \quad V_{SS} = 0 V$$

Reset active

$$T_A = -40 \text{ to } +85 \text{ }^\circ\text{C}$$

Parameter	Symbol		Limit Values		Unit	Test Condition
			min.	max.		
Input low voltage	V_{IL}	SR	-0.3	0.8	V	-
Input high voltage (all except \overline{RSTIN} and XTAL1)	V_{IH}	SR	2.0	$V_{DD} + 0.3$	V	-
Input high voltage \overline{RSTIN} , RPD	V_{IH1}	SR	$0.6 V_{DD}$	$V_{DD} + 0.3$	V	-
Input high voltage XTAL1	V_{IH2}	SR	$0.7 V_{DD}$	$V_{DD} + 0.3$	V	-
Output low voltage (ALE, RD, WR, BHE, CLKOUT, \overline{RSTIN} , \overline{RSTOUT} , CSX)	V_{OL}	CC	-	0.4	V	$I_{OL} = 4 \text{ mA}$
Output low voltage (all other outputs)	V_{OL1}	CC	-	0.4	V	$I_{OL1} = 2 \text{ mA}$
Output high voltage ALE, RD, WR, BHE, CLKOUT, \overline{RSTIN} , \overline{RSTOUT} , CSX)	V_{OH}	CC	2.4	-	V	$I_{OH} = -4 \text{ mA}$
Output high voltage ¹⁾ (all other outputs)	V_{OH1}	CC	2.4	-	V	$I_{OH} = -2 \text{ mA}$
Input leakage current (3T pins)	I_{OZ}	CC	-	± 10	μA	$0 V < V_{IN} < V_{DD}$
Input leakage current (5T, 5S pins)	I_{OZ1}	CC	-	± 10 $\pm 100^7)$	μA μA	$0 V < V_{IN} < V_{DD}$ $V_{DD} < V_{IN} < 5.0V^7)$
\overline{RSTIN} pull-up resistor ²⁾	R_{RST}	CC	20	300	$k\Omega$	$V_{IN} = 0 V$
Read/Write pullup current ³⁾	I_{RWH} ⁴⁾		-	-40	μA	$V_{OUT} = 2.4 V$
Read/Write pullup current ³⁾	I_{RWL} ⁵⁾		-500	-	μA	$V_{OUT} = 0.4 V$
ALE pulldown current ³⁾	I_{ALEL} ⁴⁾		40	-	μA	$V_{OUT} = 0.4 V$
ALE pulldown current ³⁾	I_{ALEH} ⁵⁾		-	500	μA	$V_{OUT} = 2.4 V$
Port 6 (\overline{CS}) pullup current ³⁾	I_{P6H} ⁴⁾		-	-40	μA	$V_{OUT} = 2.4 V$
Port 6 (\overline{CS}) pullup current ³⁾	I_{P6L} ⁵⁾		-500	-	μA	$V_{OUT} = 0.4 V$

Table 14 DC characteristics

ST10R272L - ELECTRICAL CHARACTERISTICS

Parameter	Symbol	Limit Values		Unit	Test Condition
		min.	max.		
PORT0 configuration current ³	I_{POH} ⁴	–	-4	μA	$V_{IN} = V_{IHmin}$
	I_{POL} ⁵	-50	–	μA	$V_{IN} = V_{ILmax}$
RPD pulldown current ²	I_{RPD} ⁵	100	500	μA	$V_{OUT} = V_{DD}$
XTAL1 input current	I_{IL} CC	–	± 20	μA	$0\text{ V} < V_{IN} < V_{DD}$
Pin capacitance ⁶⁾ (digital inputs/outputs)	C_{IO} CC	–	10	pF	$f = 1\text{ MHz}$ $T_A = 25\text{ }^\circ\text{C}$
Power supply current	I_{CC}	–	$15 + 2.5 * f_{CPU}$	mA	f_{CPU} in [MHz] ⁷⁾
Idle mode supply current	I_{ID}	–	$10 + 0.9 * f_{CPU}$	mA	$\overline{RSTIN} = V_{IH1}$ f_{CPU} in [MHz] ⁷⁾
Power-down mode supply current	I_{PD} ⁸	–	200	μA	$V_{DD} = 3.6\text{ V}$ ⁹⁾

Table 14 DC characteristics

- 1) This specification is not valid for outputs which are switched to open drain mode. In this case the respective output will float and the resulting voltage comes from the external circuitry.
- 2) This specification is only valid during reset, or interruptible power-down mode, after reception of an external interrupt signal that will wake up the CPU.
- 3) This specification is only valid during reset, hold or adapt-mode. Port 6 pins are only affected if they are used for \overline{CS} output and the open drain function is not enabled.
- 4) The maximum current may be drawn while the signal line remains inactive.
- 5) The minimum current must be drawn in order to drive the signal line active.
- 6) Not 100% tested, guaranteed by design characterization.
- 7) Supply current is a function of operating frequency as illustrated in Figure 10 on page 44. This parameter is tested at V_{DDmax} and 50 MHz CPU clock with all outputs disconnected and all inputs at V_{IL} or V_{IH} with an infinite execution of NOP instruction fetched from external memory (16-bit demux bus mode, no waitstates, no memory tri-state waitstates, normal ALE).
- 8) Typical value at $25^\circ\text{C} = 20\text{ }\mu\text{A}$.
- 9) This parameter is tested including leakage currents. All inputs (including pins configured as inputs) at 0 V to 0.1 V or at $V_{DD} - 0.1\text{ V}$ to V_{DD} , $V_{REF} = 0\text{ V}$, all outputs (including pins configured as outputs) disconnected.

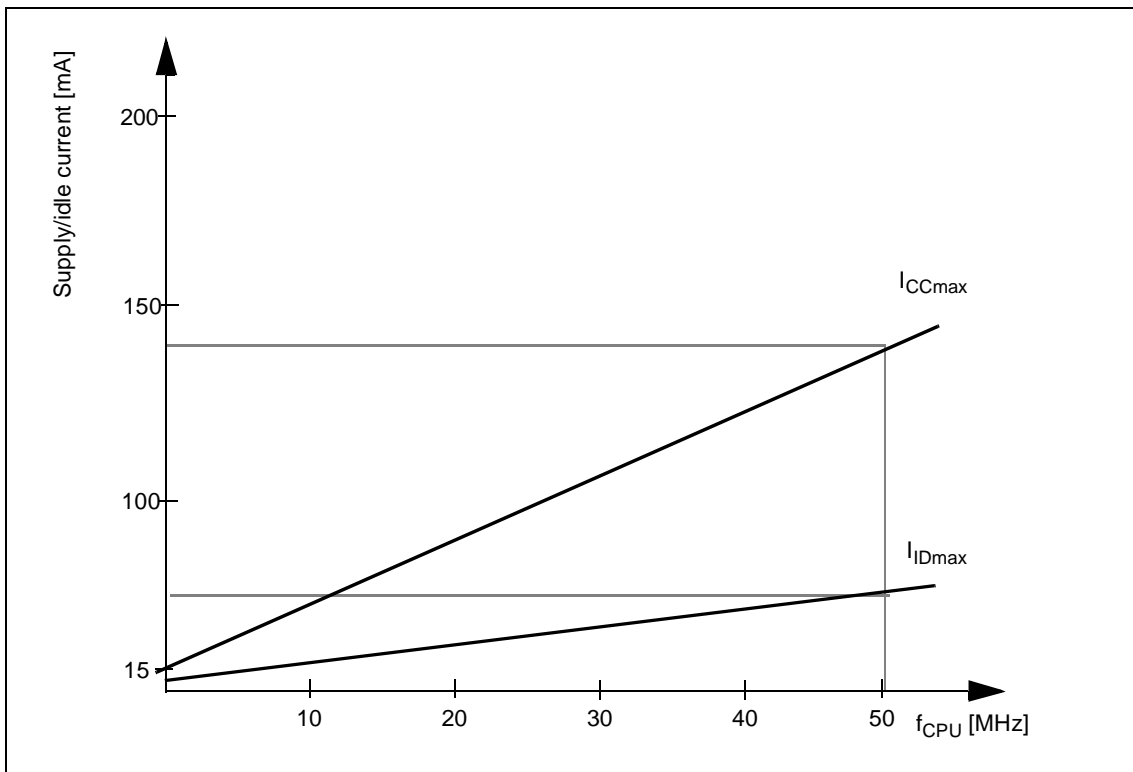

Figure 10 Supply/idle current vs operating frequency

16.3 AC Characteristics

Test conditions

- Input pulse levels: 0 to +3.0 V
- Input rise and fall times (10%-90%): 2.5 ns
- Input timing reference levels: +1.5 V
- Output timing reference levels: +1.5 V
- Output load: see Figure 12

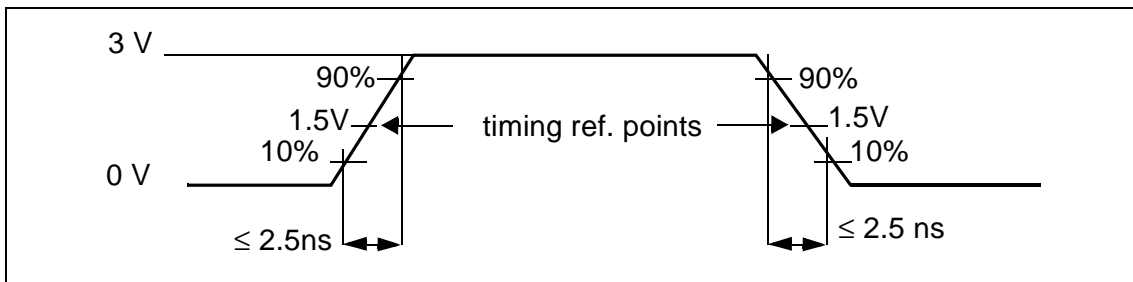

Figure 11 Input waveforms

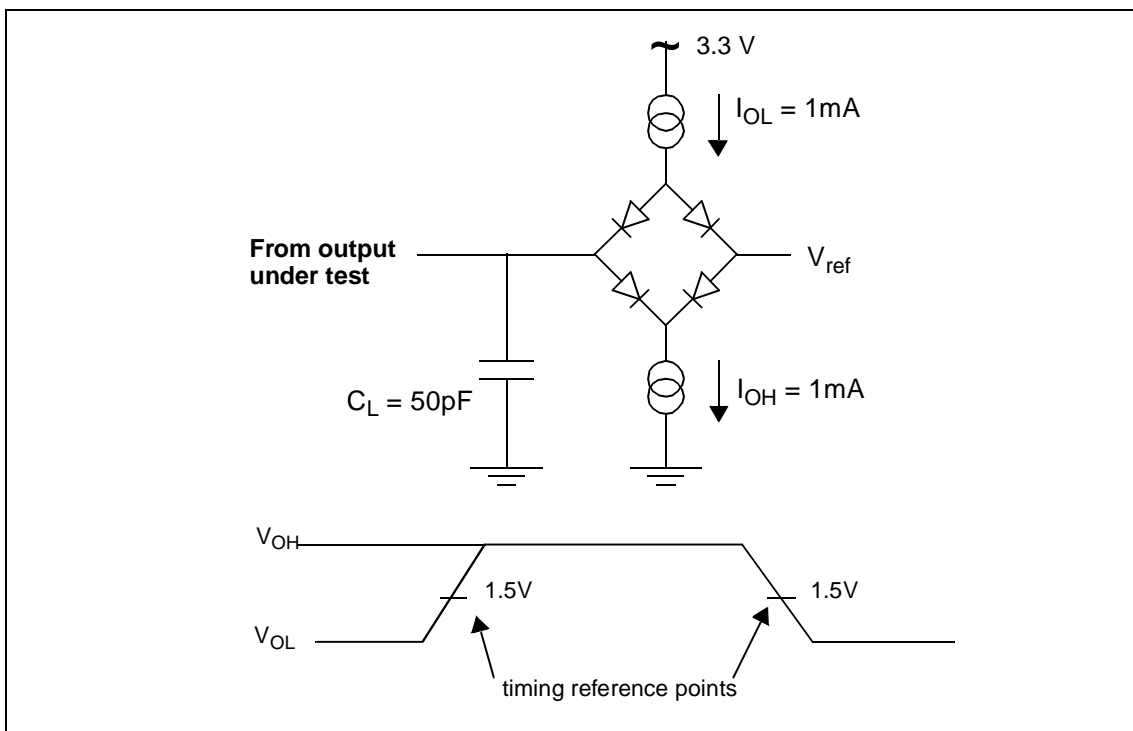

Figure 12 Output load circuit waveform

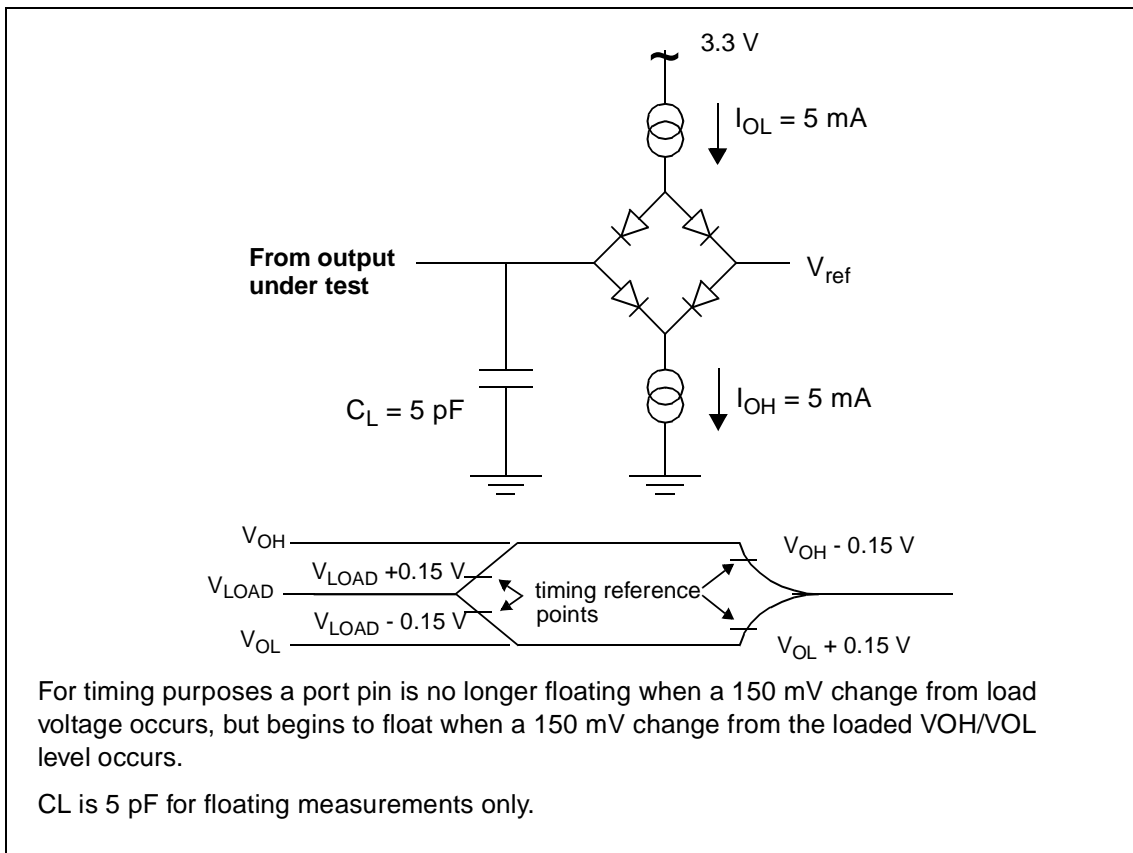

Figure 13 Float waveforms

16.3.1 CPU Clock Generation Mechanisms

ST10R272L internal operation is controlled by the CPU clock f_{CPU} . Both edges of the CPU clock can trigger internal (e.g. pipeline) or external (e.g. bus cycles) operations. The external timing (AC Characteristics) specification therefore depends on the time between two consecutive edges of the CPU clock, called “TCL” (see figure below).

The CPU clock signal can be generated by different mechanisms. The duration of TCLs and their variation (and also the external timing) depends on the f_{CPU} generation mechanism. This must be considered when calculating ST10R272L timing.

The CPU clock generation mechanism is set during reset by the logic levels on pins P0.15-13 (P0H.7-5).

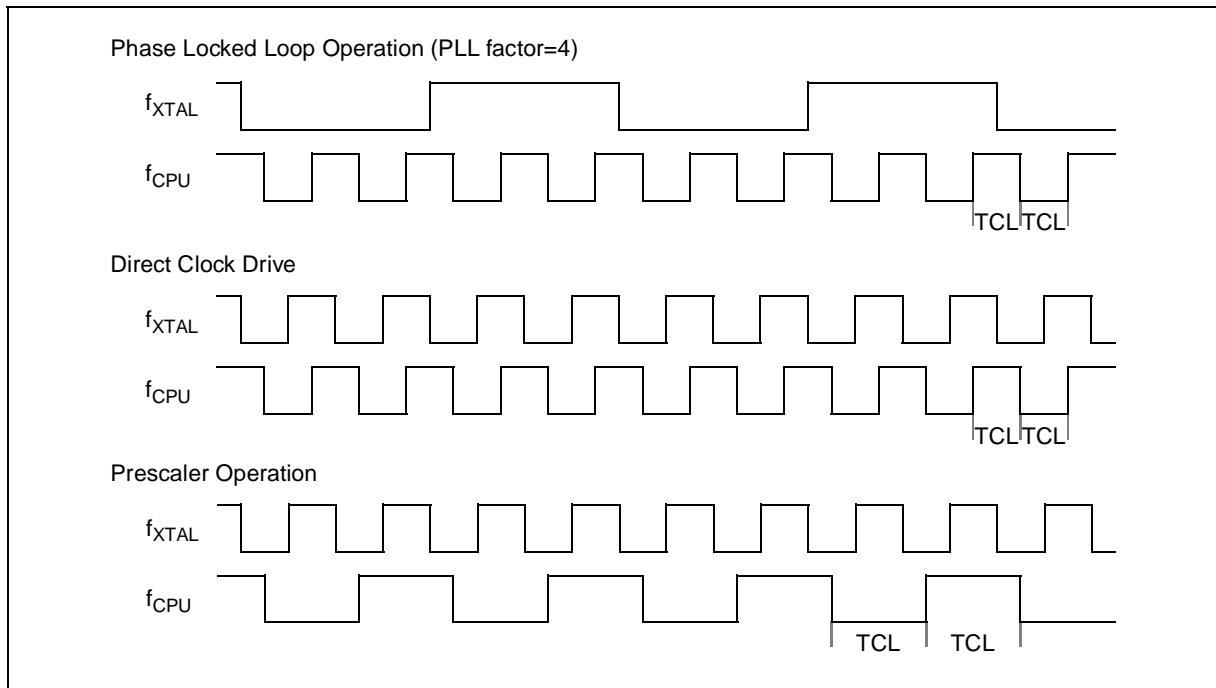

Figure 14 CPU clock generation mechanisms

P0.15-13 (P0H.7-5)			CPU frequency $f_{CPU} = f_{XTAL} * F$	External clock input range 10- 50MHz	Notes
1	1	1	$F_{XTAL} * 4$	2.5 to 12.5 MHz	Default configuration
1	1	0	$F_{XTAL} * 3$	3.33 to 16.66 MHz	
1	0	1	$F_{XTAL} * 2$	5 to 25 MHz	

Table 15 CPU clock generation mechanisms

P0.15-13 (P0H.7-5)			CPU frequency $f_{CPU} = f_{XTAL} * F$	External clock input range 10- 50MHz	Notes
1	0	0	$F_{XTAL} * 5$	2 to 10 MHz	
0	1	1	$F_{XTAL} * 1$	1 to 50 MHz	Direct drive ¹⁾
0	1	0	$F_{XTAL} * 1.5$	6.66 to 33.33 MHz	
0	0	1	$F_{XTAL} / 2$	2 to 100 MHz	CPU clock via 2:1 prescaler
0	0	0	$F_{XTAL} * 2.5$	4 to 20 MHz	

Table 15 CPU clock generation mechanisms

- 1) The maximum depends on the duty cycle of the external clock signal. The maximum input frequency is 25 MHz when using an external crystal oscillator, but higher frequencies can be applied with an external clock source.

Prescaler operation

Set when pins P0.15-13 (P0H.7-5) equal '001' during reset, the CPU clock is derived from the internal oscillator (input clock signal) by a 2:1 prescaler.

The frequency of f_{CPU} is half the frequency of f_{XTAL} and the high and low time of f_{CPU} (i.e. the duration of an individual TCL) is defined by the period of the input clock f_{XTAL} .

The timings listed in the AC characteristics that refer to TCLs therefore can be calculated using the period of f_{XTAL} for any TCL.

Note that if the bit OWDDIS in SYSCON register is cleared, the PLL runs on its free-running frequency and delivers the clock signal for the Oscillator Watchdog. If bit OWDDIS is set, then the PLL is switched off.

Direct drive

When pins P0.15-13 (P0H.7-5) equal '011' during reset, the on-chip phase locked loop is disabled and the CPU clock is driven from the internal oscillator with the input clock signal. The frequency of f_{CPU} directly follows the frequency of f_{XTAL} so the high and low time of f_{CPU} (i.e. the duration of an individual TCL) is defined by the duty cycle of the input clock f_{XTAL} .

The TCL timing below must be calculated using the minimum possible TCL which can be calculated by the formula: $TCL_{min} = 1/f_{XTAL} \times DC_{min}$ ($DC =$ duty cycle)

For two consecutive TCLs the deviation caused by the duty cycle of f_{XTAL} is compensated so the duration of 2TCL is always $1/f_{XTAL}$. Therefore, the minimum value TCL_{min} has to be used only once for timings that require an odd number of TCLs (1,3,...). Timings that require an even number of TCLs (2,4,...) may use the formula: $2TCL = 1/f_{XTAL}$.

Note The address float timings in Multiplexed bus mode (t_{11} and t_{45}) use

$$TCL_{max} = 1/f_{XTAL} \times DC_{max} \text{ instead of } TCL_{min}.$$

Note that if the bit OWDDIS in SYSCON register is cleared, the PLL runs on its free-running frequency and delivers the clock signal for the Oscillator Watchdog. If bit OWDDIS is set, then the PLL is switched off.

Oscillator Watchdog (OWD)

When the clock option selected is direct drive or direct drive with prescaler, in order to provide a fail safe mechanism in case of a loss of the external clock, an oscillator watchdog is implemented as an additional functionality of the PLL circuitry. This oscillator watchdog operates as follows:

After a reset, the Oscillator Watchdog is enabled by default. To disable the OWD, set bit 4 of SYSCON register OWDDIS.

When the OWD is enabled, the PLL runs on its free-running frequency and increments the Oscillator Watchdog counter. On each transition of the XTAL1 pin, the Oscillator Watchdog is cleared. If an external clock failure occurs, then the Oscillator Watchdog counter overflows (after 16 PLL clock cycles). The CPU clock signal will be switched to the PLL free-running clock signal, and the Oscillator Watchdog Interrupt Request (XP3INT) is flagged. The CPU clock will not switch back to the external clock even if a valid external clock exists on XTAL1 pin. Only a hardware reset can switch the CPU clock source back to direct clock input.

When the OWD is disabled, the CPU clock is always fed from the oscillator input and the PLL is switched off to decrease power supply current.

Phase locked loop

For all other combinations of pins P0.15-13 (P0H.7-5) during reset the on-chip phase locked loop is enabled and provides the CPU clock. The PLL multiplies the input frequency by the factor F which is selected via the combination of pins P0.15-13 (i.e. $f_{CPU} = f_{XTAL} * F$). With every F'th transition of f_{XTAL} the PLL circuit synchronizes the CPU clock to the input clock. In this way, f_{CPU} is constantly adjusted so it is locked to f_{XTAL} . The slight variation causes a jitter of f_{CPU} which affects individual TCL duration. Therefore, AC characteristics that refer to TCLs must be calculated using the minimum possible TCL.

The actual minimum value for TCL depends on the jitter of the PLL. As the PLL constantly adjusts its output frequency, it corresponds to the applied input frequency (crystal or oscillator). The relative deviation for periods of more than one TCL is lower than for one single TCL. For a period of $N * TCL$ the minimum value is computed using the corresponding deviation D_N :

$$TCL_{min} = TCL_{NOM} \times (1 - |D_N|/100)$$

$$D_N = \pm(4 - N/15)[\%]$$

ST10R272L - ELECTRICAL CHARACTERISTICS

where N = number of consecutive TCLs and $1 \leq N \leq 40$. So for a period of 3 TCLs (i.e. $N = 3$):

$$\begin{aligned} D_3 &= 4 - 3/15 \\ &= 3,8\% \end{aligned}$$

and

$$\begin{aligned} 3TCL_{min} &= 3TCL_{NOM} \times (1 - 3,8/100) \\ &= 3TCL_{NOM} \times 0,962 (36.07\text{nsec @fcpu=50MHz}) \end{aligned}$$

PLL jitter is an important factor for bus cycles using waitstates and for the operation of timers, serial interfaces, etc. For slower operations and longer periods (e.g. pulse train generation or measurement, lower baudrates, etc.) the deviation caused by the PLL jitter is negligible.

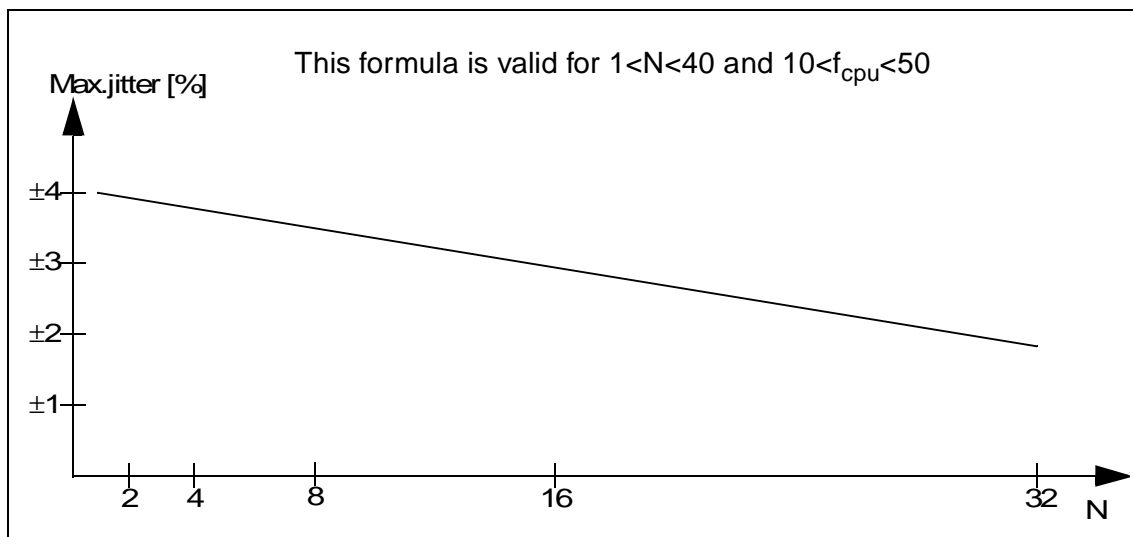

Figure 15 Approximated maximum PLL jitter

16.3.2 Memory Cycle Variables

The timing tables below use three variables derived from the BUSCONx registers and represent programmed memory cycle characteristics. Table 16 describes how these variables are computed.

Description	Symbol	Values
ALE Extension	t_A	$TCL * \langle ALECTL \rangle$
Memory Cycle Time Waitstates	t_C	$2TCL * (15 - \langle MCTC \rangle)$
Memory Tristate Time	t_F	$2TCL * (1 - \langle MTTC \rangle)$

Table 16 Memory cycle variables

ST10R272L - ELECTRICAL CHARACTERISTICS

16.3.3 Multiplexed Bus

$$V_{DD} = 3.3 \text{ V} \pm 0.3 \text{ V} \quad V_{SS} = 0 \text{ V} \quad T_A = -40 \text{ to } +85 \text{ }^\circ\text{C} \quad C_L = 50 \text{ pF}$$

ALE cycle time = $6 \text{ TCL} + 2t_A + t_C + t_F$ (60 ns at 50-MHz CPU clock without waitstates)

Parameter	Symbol		Max. CPU Clock = 50 MHz		Variable CPU Clock 1/2TCL = 1 to 50 MHz		Unit
			min.	max.	min.	max.	
ALE high time	t_5	CC	$7 + t_A$	–	$\text{TCL} - 3 + t_A$	–	ns
Address (P1, P4), $\overline{\text{BHE}}$ setup to ALE	t_6	CC	$3 + t_A$	–	$\text{TCL} - 7 + t_A$	–	ns
Address (P0) setup to ALE	t_{6m}	CC	$5 + t_A$	–	$\text{TCL} - 5 + t_A$	–	ns
Address hold after ALE	t_7	CC	$5 + t_A$	–	$\text{TCL} - 5 + t_A$	–	ns
ALE falling edge to $\overline{\text{RD}}$, $\overline{\text{WR}}$ (with RW-delay)	t_8	CC	$5 + t_A$	–	$\text{TCL} - 5 + t_A$	–	ns
ALE falling edge to $\overline{\text{RD}}$, $\overline{\text{WR}}$ (no RW-delay)	t_9	CC	$-5 + t_A$	–	$-5 + t_A$	–	ns
Address float after $\overline{\text{RD}}$, (with RW-delay) ¹⁾	t_{10}	CC	–	5^1	–	5^1	ns
Address float after $\overline{\text{RD}}$, (no RW-delay) ¹⁾	t_{11}	CC	–	15^1	–	$\text{TCL} + 5^1$	ns
$\overline{\text{RD}}$, $\overline{\text{WR}}$ low time (with RW-delay)	t_{12}	CC	$13 + t_C$	–	$2\text{TCL} - 7 + t_C$	–	ns
$\overline{\text{RD}}$, $\overline{\text{WR}}$ low time (no RW-delay)	t_{13}	CC	$23 + t_C$	–	$3\text{TCL} - 7 + t_C$	–	ns
$\overline{\text{RD}}$ to valid data in (with RW-delay)	t_{14}	SR	–	$5 + t_C$	–	$2\text{TCL} - 15 + t_C$	ns
$\overline{\text{RD}}$ to valid data in (no RW-delay)	t_{15}	SR	–	$15 + t_C$	–	$3\text{TCL} - 15 + t_C$	ns
ALE low to valid data in	t_{16}	SR	–	$15 + t_A + t_C$	–	$3\text{TCL} - 15 + t_A + t_C$	ns
Address to valid data in	t_{17}	SR	–	$20 + 2t_A + t_C$	–	$4\text{TCL} - 20 + 2t_A + t_C$	ns

Table 17 Multiplexed bus

ST10R272L - ELECTRICAL CHARACTERISTICS

Parameter	Symbol	Max. CPU Clock = 50 MHz		Variable CPU Clock 1/2TCL = 1 to 50 MHz		Unit
		min.	max.	min.	max.	
Data hold after \overline{RD} rising edge	t ₁₈ SR	0	–	0	–	ns
Data float after \overline{RD} rising edge ¹²⁾⁾	t ₁₉ SR	–	$15 + t_F^2$	–	$2TCL - 5 + t_F^2$	ns
Data valid to \overline{WR}	t ₂₂ CC	$13 + t_C$	–	$2TCL - 7 + t_C$	–	ns
Data hold after \overline{WR}	t ₂₃ CC	$13 + t_F$	–	$2TCL - 7 + t_F$	–	ns
ALE rising edge after \overline{RD} , \overline{WR}	t ₂₅ CC	$10 + t_F$	–	$2TCL - 10 + t_F$	–	ns
Address hold after \overline{RD} , \overline{WR}	t ₂₇ CC	$10 + t_F$	–	$2TCL - 10 + t_F$	–	ns
Latched \overline{CS} setup to ALE	t ₃₈ CC	$-7 + t_A$	$3 + t_A$	$-7 + t_A$	$3 + t_A$	ns
Unlatched \overline{CS} setup to ALE	t _{38u} CC	$3 + t_A$	–	$TCL - 7 + t_A$	–	ns
Latched \overline{CS} low to Valid Data In	t ₃₉ SR	–	$13 + t_C + 2t_A$	–	$3TCL - 17 + t_C + 2t_A$	ns
Unlatched \overline{CS} low to Valid Data In	t _{39u} SR	–	$23 + t_C + 2t_A$	–	$4TCL - 17 + t_C + 2t_A$	ns
Latched \overline{CS} hold after \overline{RD} , \overline{WR}	t ₄₀ CC	$20 + t_F$	–	$3TCL - 10 + t_F$	–	ns
Unlatched \overline{CS} hold after \overline{RD} , \overline{WR}	t _{40u} CC	$10 + t_F$	–	$2TCL - 10 + t_F$	–	ns
ALE fall. edge to \overline{RdCS} , \overline{WrCS} (with RW delay)	t ₄₂ CC	$7 + t_A$	–	$TCL - 3 + t_A$	–	ns
ALE fall. edge to \overline{RdCS} , \overline{WrCS} (no RW delay)	t ₄₃ CC	$-3 + t_A$	–	$-3 + t_A$	–	ns
Address float after \overline{RdCS} (with RW delay) ¹	t ₄₄ CC	–	3^1	–	3^1	ns
Address float after \overline{RdCS} (no RW delay) ¹	t ₄₅ CC	–	13^1	–	$TCL + 3^1$	ns

Table 17 Multiplexed bus

ST10R272L - ELECTRICAL CHARACTERISTICS

Parameter	Symbol	Max. CPU Clock = 50 MHz		Variable CPU Clock 1/2TCL = 1 to 50 MHz		Unit
		min.	max.	min.	max.	
$\overline{\text{RdCS}}$ to Valid Data In (with RW delay)	t ₄₆ SR	–	3 + t _C	–	2TCL - 17 + t _C	ns
$\overline{\text{RdCS}}$ to Valid Data In (no RW delay)	t ₄₇ SR	–	13 + t _C	–	3TCL - 17 + t _C	ns
$\overline{\text{RdCS}}$, $\overline{\text{WrCS}}$ Low Time (with RW delay)	t ₄₈ CC	13 + t _C	–	2TCL - 7 + t _C	–	ns
$\overline{\text{RdCS}}$, $\overline{\text{WrCS}}$ Low Time (no RW delay)	t ₄₉ CC	23 + t _C	–	3TCL - 7 + t _C	–	ns
Data valid to $\overline{\text{WrCS}}$	t ₅₀ CC	10 + t _C	–	2TCL - 10 + t _C	–	ns
Data hold after $\overline{\text{RdCS}}$	t ₅₁ SR	0	–	0	–	ns
Data float after $\overline{\text{RdCS}}$ ^{1 2}	t ₅₂ SR	–	13 + t _F ²	–	2TCL - 7 + t _F ²	ns
Address hold after $\overline{\text{RdCS}}$, $\overline{\text{WrCS}}$	t ₅₄ CC	10 + t _F	–	2TCL - 10 + t _F	–	ns
Data hold after $\overline{\text{WrCS}}$	t ₅₆ CC	10 + t _F	–	2TCL - 10 + t _F	–	ns

Table 17 Multiplexed bus

- 1) Output loading is specified using Figure 13 (CL = 5 pF).
- 2) This delay assumes that the following bus cycle is a multiplexed bus cycle. If next bus cycle is demultiplexed, refer to demultiplexed equivalent AC timing.

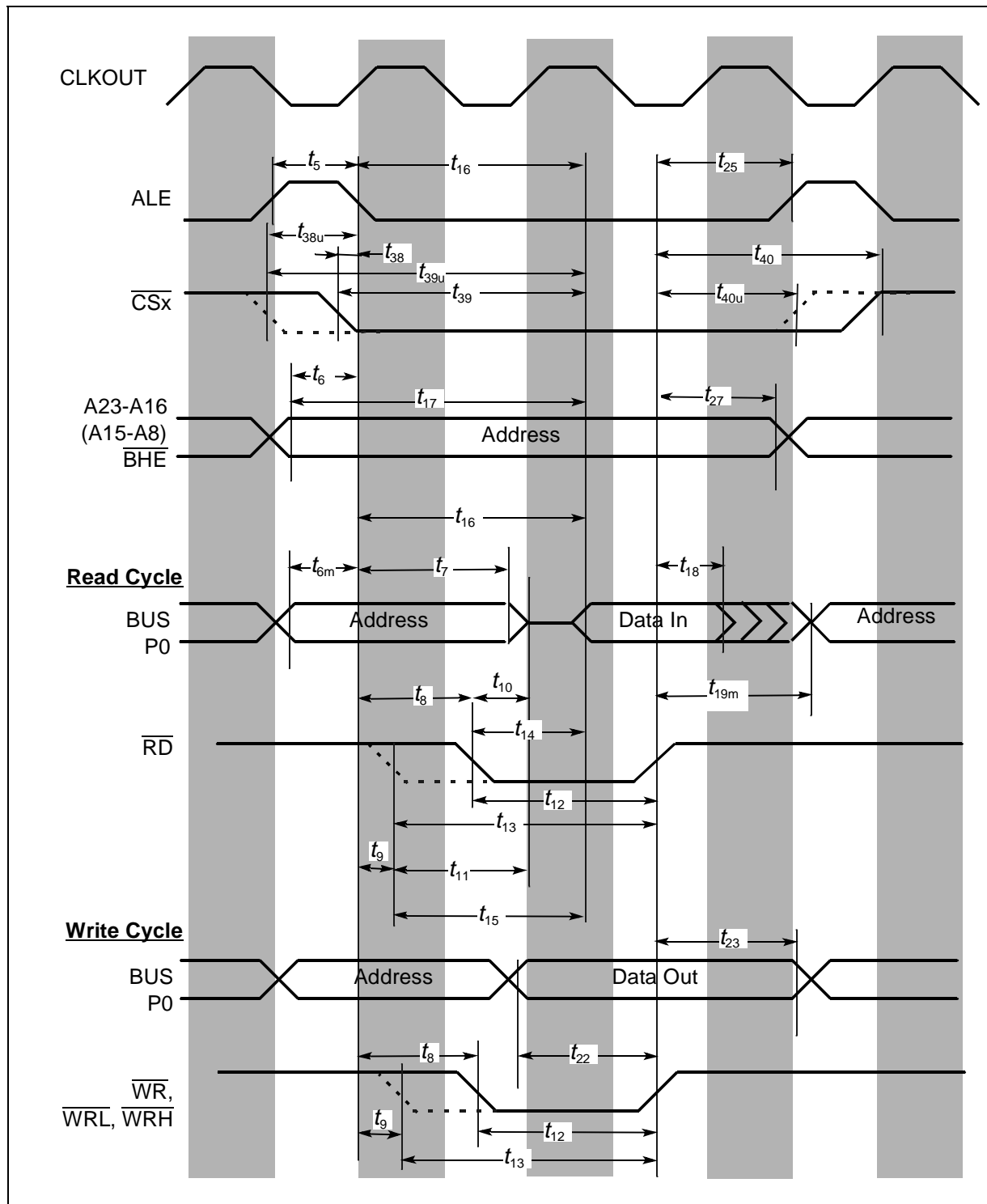

Figure 16 External memory cycle:
multiplexed bus, with/without read/write delay, normal ALE

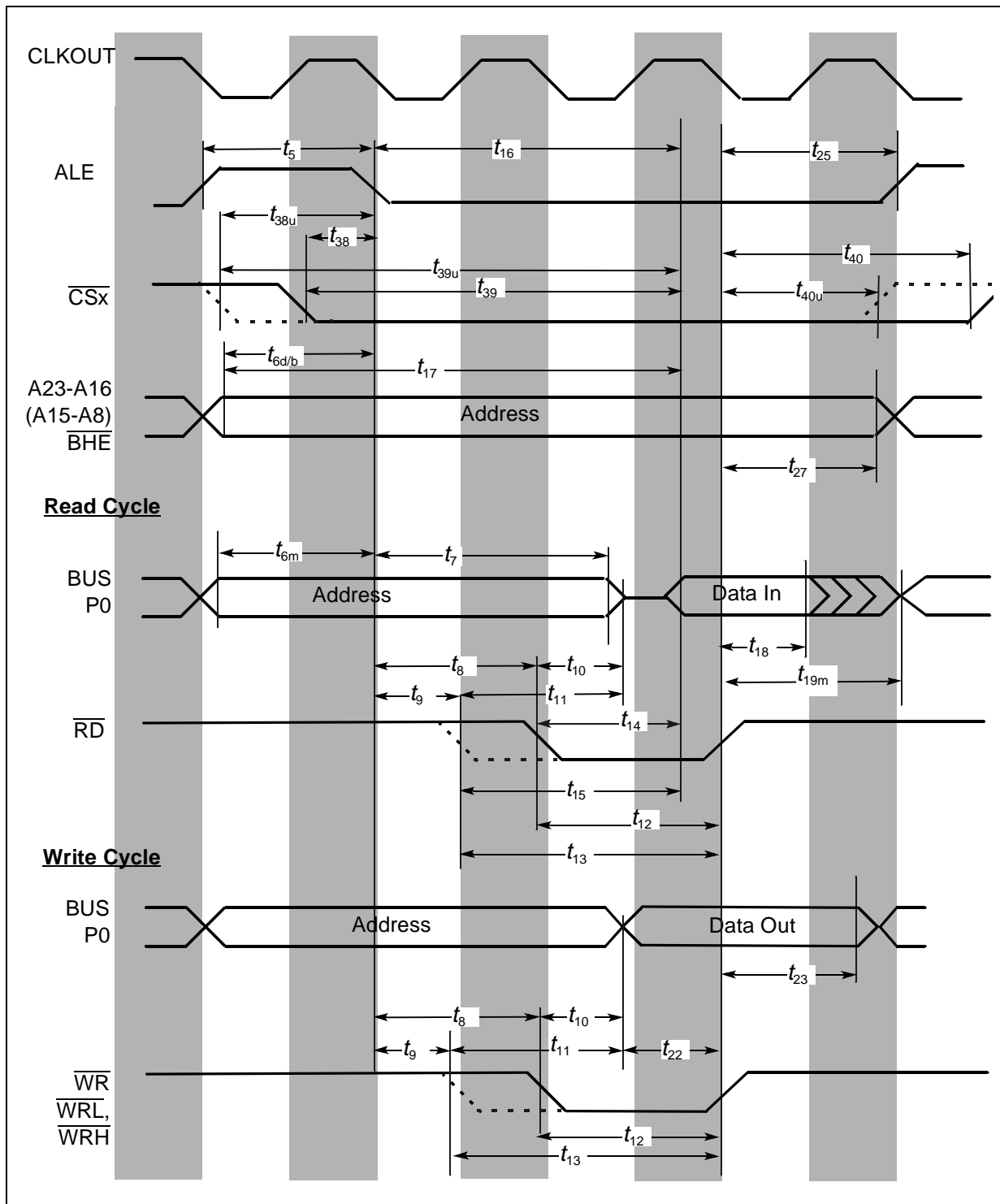

Figure 17 External memory cycle: multiplexed bus, with/without read/write delay, extended ALE

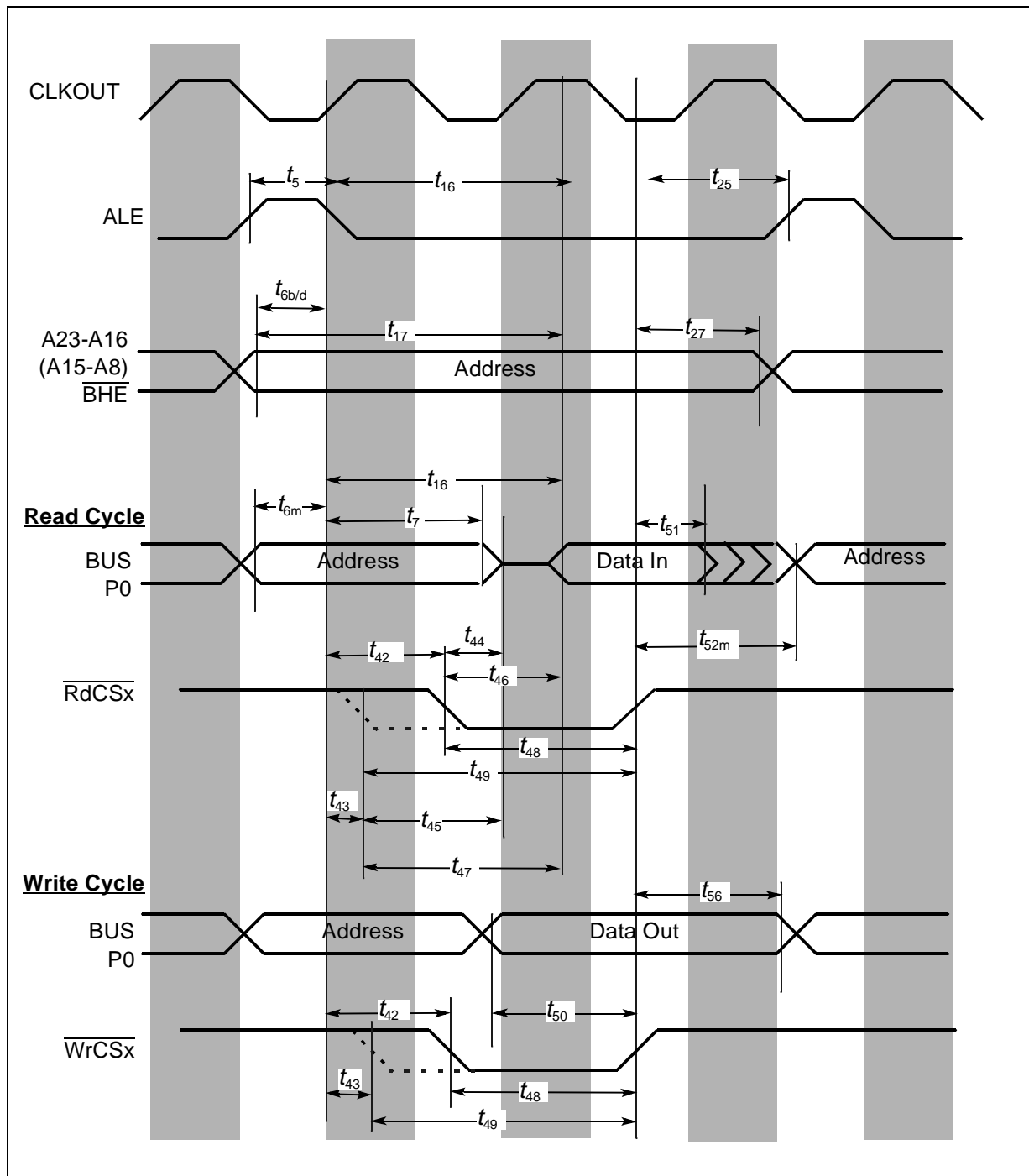

Figure 18 External memory cycle: multiplexed bus, with/without read/write delay, normal ALE, read/write chip select

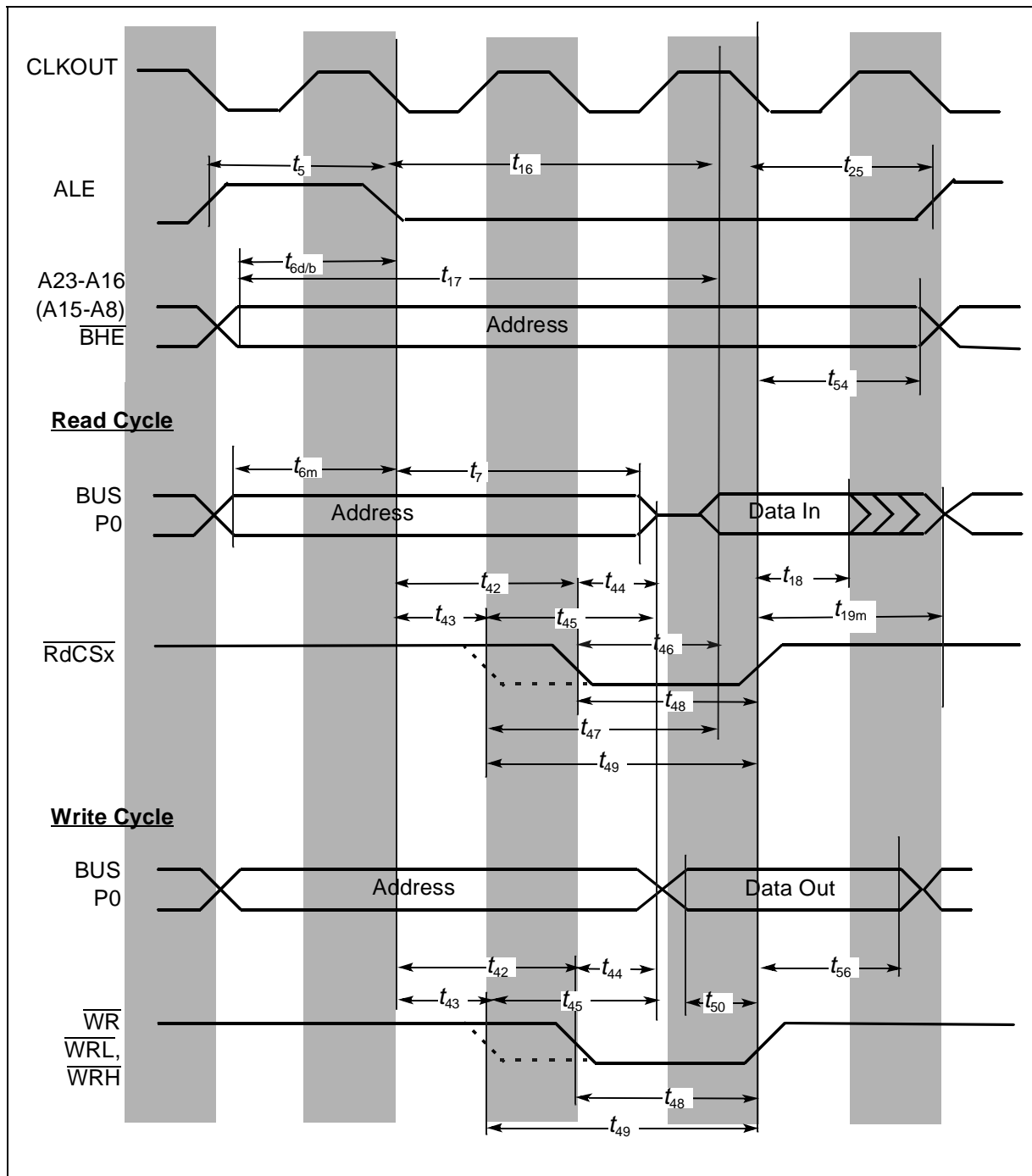

Figure 19 External memory cycle: multiplexed bus, with/without read/write delay, extended ale, read/write chip select

16.3.4 Demultiplexed Bus

$V_{DD} = 3.3\text{ V} \pm 0.3\text{ V}$ $V_{SS} = 0\text{ V}$ $T_A = -40\text{ to }+85\text{ }^\circ\text{C}$ $C_L = 50\text{ pF}$
 ALE cycle time = $4\text{ TCL} + 2t_A + t_C + t_F$ (40 ns at 50 MHz CPU clock without waitstates)

Parameter	Symbol	Max CPU Clock 50MHz		Variable CPU Clock 1/2TCL = 1 to 50 MHz		Unit
		min.	max.	min.	max.	
ALE high time	t_5 CC	$7 + t_A$	–	$\text{TCL} - 3 + t_A$	–	ns
Address (P1, P4), $\overline{\text{BHE}}$ setup to ALE	t_6 CC	$3 + t_A$	–	$\text{TCL} - 7 + t_A$	–	ns
Address setup to $\overline{\text{RD}}$, $\overline{\text{WR}}$ (with RW-delay)	t_{80} CC	$13 + 2t_A$	–	$2\text{TCL} - 7 + 2t_A$	–	ns
Address setup to $\overline{\text{RD}}$, $\overline{\text{WR}}$ (no RW-delay)	t_{81} CC	$3 + 2t_A$	–	$\text{TCL} - 7 + 2t_A$	–	ns
$\overline{\text{RD}}$, $\overline{\text{WR}}$ low time (with RW-delay)	t_{12} CC	$13 + t_C$	–	$2\text{TCL} - 7 + t_C$	–	ns
$\overline{\text{RD}}$, $\overline{\text{WR}}$ low time (no RW-delay)	t_{13} CC	$23 + t_C$	–	$3\text{TCL} - 7 + t_C$	–	ns
$\overline{\text{RD}}$ to valid data in (with RW-delay)	t_{14} SR	–	$5 + t_C$	–	$2\text{TCL} - 15 + t_C$	ns
$\overline{\text{RD}}$ to valid data in (no RW-delay)	t_{15} SR	–	$15 + t_C$	–	$3\text{TCL} - 15 + t_C$	ns
ALE low to valid data in	t_{16} SR	–	$15 + t_A + t_C$	–	$3\text{TCL} - 15 + t_A + t_C$	ns
Address to valid data in	t_{17} SR	–	$20 + 2t_A + t_C$	–	$4\text{TCL} - 20 + 2t_A + t_C$	ns
Data hold after $\overline{\text{RD}}$ rising edge	t_{18} SR	0	–	0	–	ns
Data float after $\overline{\text{RD}}$ rising edge (with RW-delay) ^{1) 2)}	t_{20} SR	–	$15 + t_F + 2t_A^2$	–	$2\text{TCL} - 5 + t_F + 2t_A^2$	ns
Data float after $\overline{\text{RD}}$ rising edge (no RW-delay) ^{1) 2)}	t_{21} SR	–	$5 + t_F + 2t_A^2$	–	$\text{TCL} - 5 + t_F + 2t_A^2$	ns
Data valid to $\overline{\text{WR}}$	t_{22} CC	$13 + t_C$	–	$2\text{TCL} - 7 + t_C$	–	ns

Table 18 Demultiplexed bus

ST10R272L - ELECTRICAL CHARACTERISTICS

Parameter	Symbol	Max CPU Clock 50MHz		Variable CPU Clock 1/2TCL = 1 to 50 MHz		Unit
		min.	max.	min.	max.	
Data hold after \overline{WR}	t ₂₄ CC	5 + t _F	–	TCL - 5 + t _F	–	ns
ALE rising edge after \overline{RD} , \overline{WR}	t ₂₆ CC	-5 + t _F	–	-5 + t _F	–	ns
Address hold after \overline{RD} , \overline{WR}	t ₂₈ CC	0 (no t _F) -9 + t _F (t _F >0)	–	0 (no t _F) -9 + t _F (t _F >0)	–	ns
Address hold after \overline{WRH}	t _{28h} CC	-1 (no t _F) -8 + t _F (t _F >0)	–	-1 (no t _F) -8 + t _F (t _F >0)	–	ns
Latched \overline{CS} setup to ALE	t ₃₈ CC	-7 + t _A	3 + t _A	-7 + t _A	3 + t _A	ns
Unlatched \overline{CS} setup to ALE	t _{38u} CC	3 + t _A	–	TCL - 7 + t _A	–	ns
Latched \overline{CS} low to Valid Data In	t ₃₉ SR	–	13 + t _C + 2t _A	–	3TCL - 17 + t _C + 2t _A	ns
Unlatched \overline{CS} low to Valid Data In	t _{39u} SR	–	23 + t _C + 2t _A	–	4TCL - 17 + t _C + 2t _A	ns
Latched \overline{CS} hold after \overline{RD} , \overline{WR}	t ₄₁ CC	3 + t _F	–	TCL - 7 + t _F	–	ns
Unlatched \overline{CS} hold after \overline{RD} , \overline{WR}	t _{41u} CC	0 (no t _F) -7 + t _F (t _F >0)	–	0 (no t _F) -7 + t _F (t _F >0)	–	ns
Address setup to \overline{RdCs} , \overline{WrCs} (with RW-delay)	t ₈₂ CC	13 + 2t _A	–	2TCL - 7 + 2t _A	–	ns
Address setup to \overline{RdCs} , \overline{WrCs} (no RW-delay)	t ₈₃ CC	3 + 2t _A	–	TCL - 7 + 2t _A	–	ns
\overline{RdCS} to Valid Data In (with RW-delay)	t ₄₆ SR	–	3 + t _C	–	2TCL - 17 + t _C	ns
\overline{RdCS} to Valid Data In (no RW-delay)	t ₄₇ SR	–	13 + t _C	–	3TCL - 17 + t _C	ns
\overline{RdCS} , \overline{WrCS} Low Time (with RW-delay)	t ₄₈ CC	11 + t _C	–	2TCL - 9 + t _C	–	ns
\overline{RdCS} , \overline{WrCS} Low Time (no RW-delay)	t ₄₉ CC	21 + t _C	–	3TCL - 9 + t _C	–	ns
Data valid to \overline{WrCS}	t ₅₀ CC	13 + t _C	–	2TCL - 7 + t _C	–	ns

Table 18 Demultiplexed bus

Parameter	Symbol	Max CPU Clock 50MHz		Variable CPU Clock 1/2TCL = 1 to 50 MHz		Unit
		min.	max.	min.	max.	
Data hold after $\overline{\text{RdCS}}$	t ₅₁ SR	0	–	0	–	ns
Data float after $\overline{\text{RdCS}}$ (with RW-delay) ^{1 2}	t ₅₃ SR	–	$13 + t_F + 2t_A^2$	–	$2\text{TCL} - 7 + t_F + 2t_A^2$	ns
Data float after $\overline{\text{RdCS}}$ (no RW-delay) ^{1 2}	t ₆₈ SR	–	$3 + t_F + 2t_A^2$	–	$\text{TCL} - 7 + t_F + 2t_A^2$	ns
Address hold after $\overline{\text{RdCS}}$, $\overline{\text{WrCS}}$	t ₅₅ CC	$-5 + t_F$	–	$-5 + t_F$	–	ns
Data hold after $\overline{\text{WrCS}}$	t ₅₇ CC	$3 + t_F$	–	$\text{TCL} - 7 + t_F$	–	ns

Table 18 Demultiplexed bus

- 1) Output loading is specified using Figure 13 with CL = 5 pF.
- 2) This delay assumes that the following bus cycle is a demultiplexed bus cycle and that the data bus will only be driven externally when the $\overline{\text{RD}}$ or $\overline{\text{RdCS}}$ signal becomes active. RW-delay and t_A refer to the following bus cycle. If the following bus cycle is a multiplexed bus cycle, refer to equivalent multiplexed AC timing (which are still applicable due to automatic insertion an idle state (2TCL) when switching from Demultiplexed to Multiplexed Bus Mode.

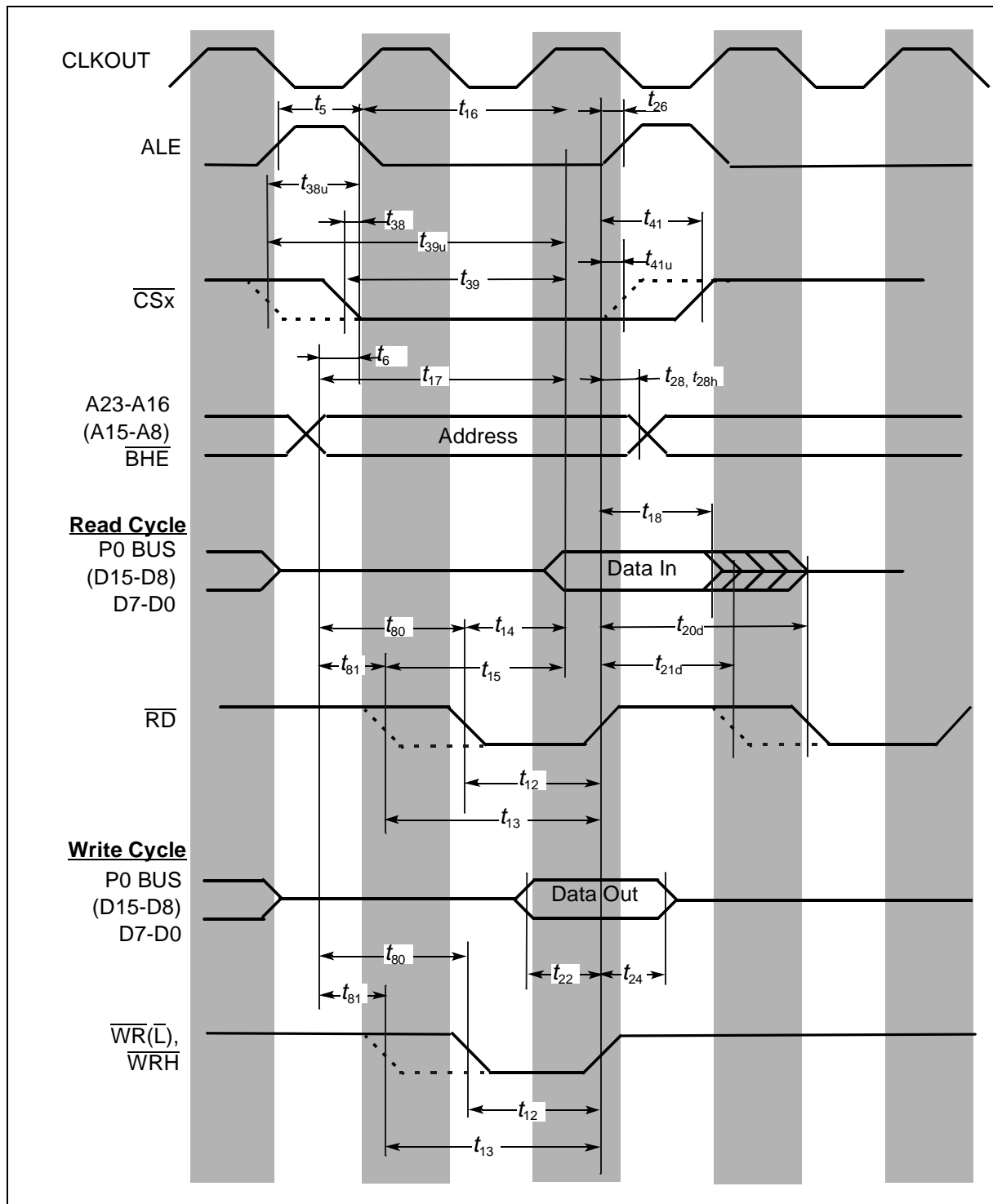

Figure 20 External memory cycle:
demultiplexed bus, with/without read/write delay, normal ALE

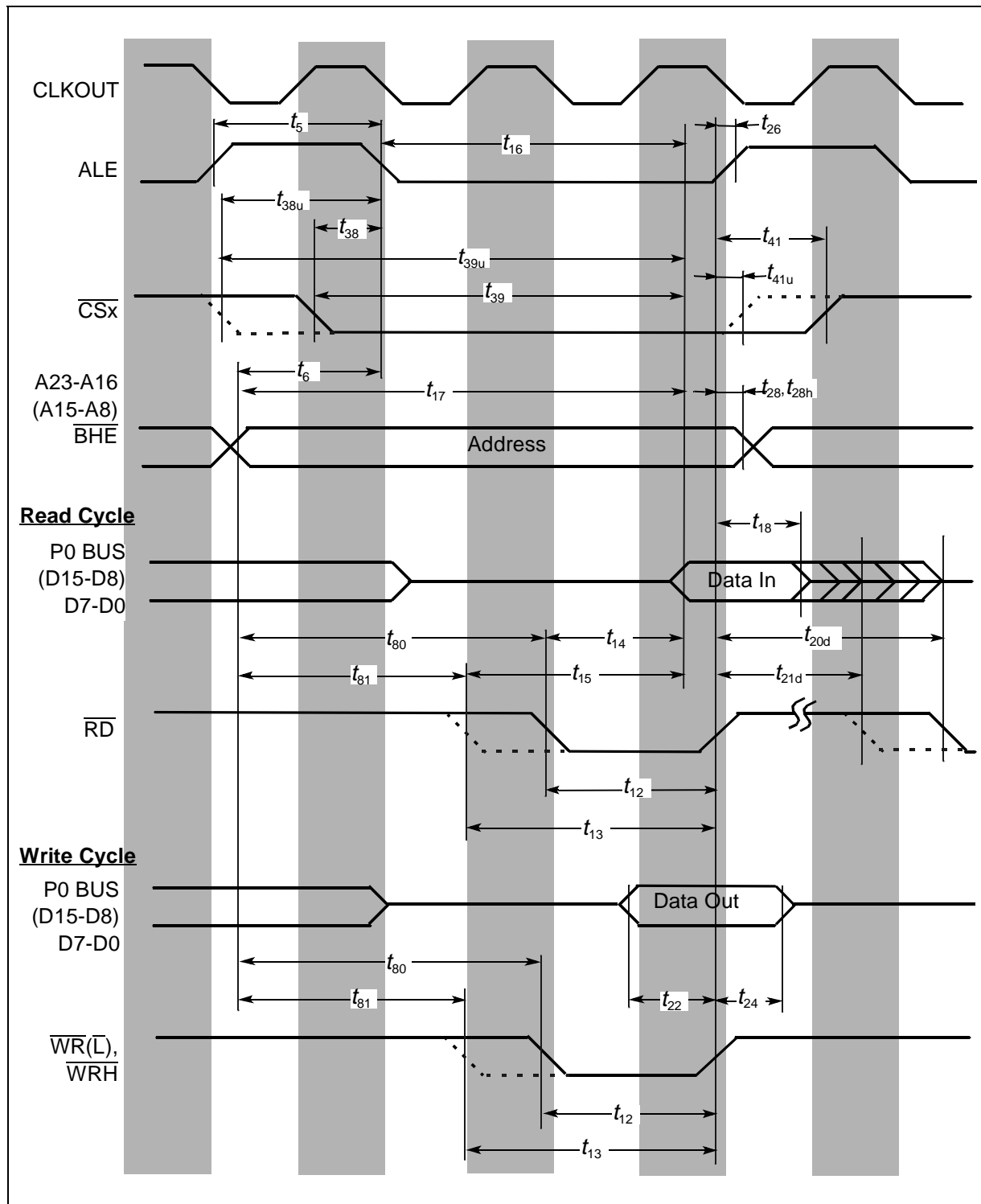

Figure 21 External memory cycle:
demultiplexed bus, with/without read/write delay, extended ALE

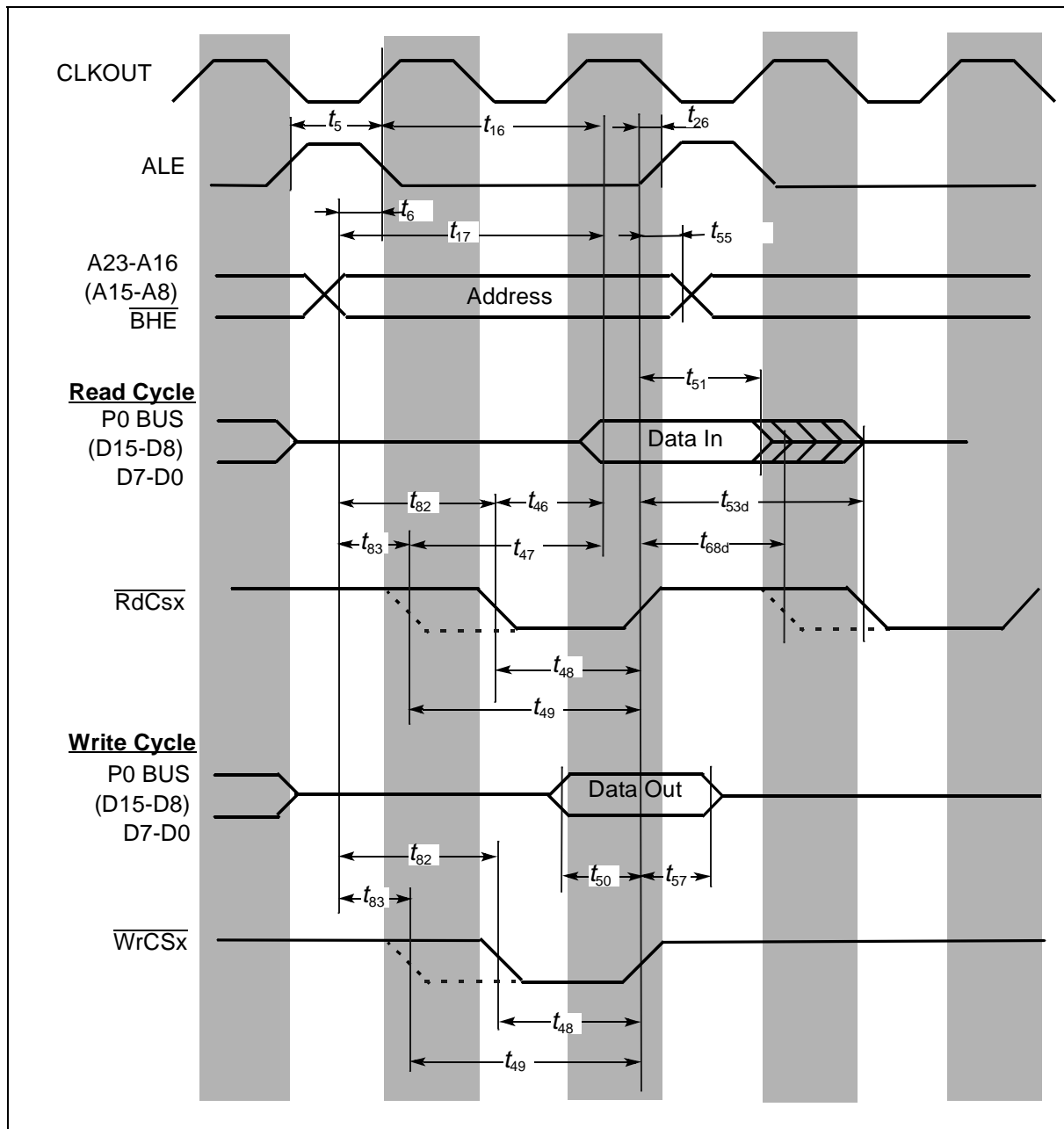

Figure 22 External memory cycle: demultiplexed bus, with/without read/write delay, normal ALE, read/write chip select

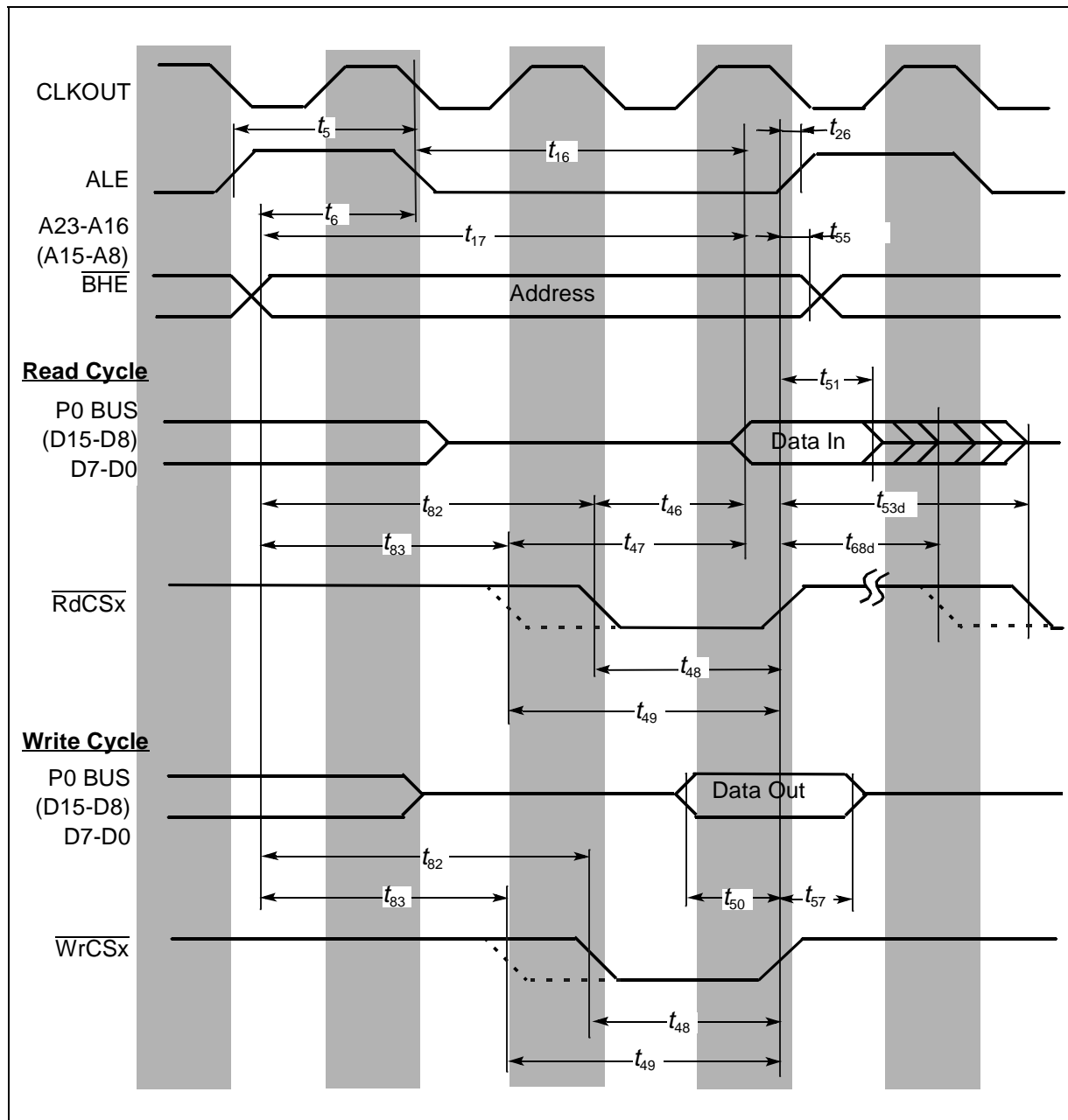

Figure 23 External memory cycle:
demultiplexed bus, no read/write delay, extended ALE, read/write chip select

ST10R272L - ELECTRICAL CHARACTERISTICS

16.3.5 CLKOUT and $\overline{\text{READY}}/\text{READY}$

$V_{DD} = 3.3 \text{ V} \pm 0.3 \text{ V}$

$V_{SS} = 0 \text{ V}$

$T_A = -40 \text{ to } +85 \text{ }^\circ\text{C}$

$C_L = 50 \text{ pF}$

Parameter	Symbol	Max. CPU Clock = 50 MHz		Variable CPU Clock 1/2TCL = 1 to 50 MHz		Unit
		min.	max.	min.	max.	
CLKOUT cycle time	t ₂₉ CC	20	20	2TCL	2TCL	ns
CLKOUT high time	t ₃₀ CC	5	–	TCL – 5	–	ns
CLKOUT low time	t ₃₁ CC	5	–	TCL – 5	–	ns
CLKOUT rise time ¹⁾	t ₃₂ CC	–	3 ¹	–	3 ¹	ns
CLKOUT fall time ¹	t ₃₃ CC	–	3 ¹	–	3 ¹	ns
CLKOUT rising edge to ALE falling edge	t ₃₄ CC	-3 + t _A	5 + t _A	-3 + t _A	5 + t _A	ns
Synchronous $\overline{\text{READY}}$ setup time to CLKOUT	t ₃₅ SR	9	–	9	–	ns
Synchronous $\overline{\text{READY}}$ hold time after CLKOUT	t ₃₆ SR	0	–	0	–	ns
Asynchronous $\overline{\text{READY}}$ low time	t ₃₇ SR	27	–	2TCL + 7	–	ns
Asynchronous $\overline{\text{READY}}$ setup time ²⁾	t ₅₈ SR	9	–	9	–	ns
Asynchronous $\overline{\text{READY}}$ hold time ²⁾	t ₅₉ SR	0	–	0	–	ns
Async. $\overline{\text{READY}}$ hold time after $\overline{\text{RD}}$, $\overline{\text{WR}}$ high (Demultiplexed Bus) ³⁾²⁾	t ₆₀ SR	0	0 + 2t _A + t _C + t _F ³	0	TCL - 10 + 2t _A + t _C + t _F ³	ns

Table 19 CLKOUT and $\overline{\text{READY}}/\text{READY}$

- 1) Measured between 0.3 and 2.7 volts
- 2) These timings assure recognition at a specific clock edge for test purposes only.
- 3) Demultiplexed bus is the worst case. For multiplexed bus, 2TCL should be added to the maximum values. This adds even more time for deactivating $\overline{\text{READY}}$. 2t_A and t_C refer to the following bus cycle, t_F refers to the current bus cycle.

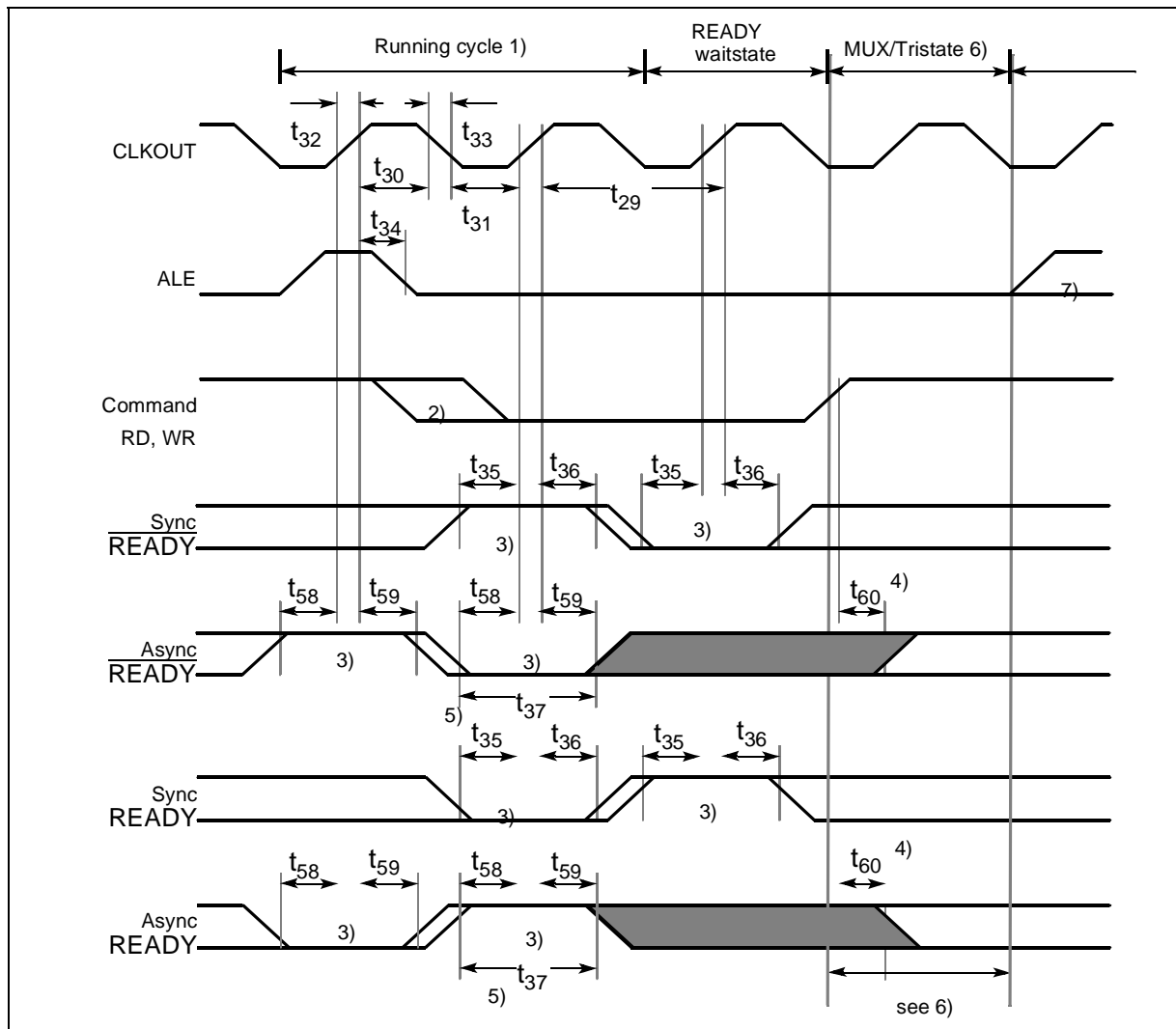

Figure 24 CLKOUT and $\overline{\text{READY}}/\text{READY}$

- 1 Cycle as programmed, including MCTC waitstates (Example shows 0 MCTC WS).
- 2 The leading edge of the respective command depends on RW-delay.
- 3 $\overline{\text{READY}}$ (or READY) sampled HIGH (resp. LOW) at this sampling point generates a READY controlled waitstate, $\overline{\text{READY}}$ (resp. READY) sampled LOW (resp. HIGH) at this sampling point terminates the currently running bus cycle.
- 4 $\overline{\text{READY}}$ (resp. READY) may be deactivated in response to the trailing (rising) edge of the corresponding command ($\overline{\text{RD}}$ or $\overline{\text{WR}}$).
- 5 If the Asynchronous $\overline{\text{READY}}$ (or READY) signal does not fulfill the indicated setup and hold times with respect to CLKOUT (e.g. because CLKOUT is not enabled), it must fulfill t_{37} in order to be safely synchronized. This is guaranteed, if READY is removed in response to the command (see Note 4)).

ST10R272L - ELECTRICAL CHARACTERISTICS

- 6 Multiplexed bus modes have a MUX waitstate added after a bus cycle, and an additional MTTC waitstate may be inserted here. For a multiplexed bus with MTTC waitstate this delay is 2 CLKOUT cycles, for a demultiplexed bus without MTTC waitstate this delay is zero.
- 7 The next external bus cycle may start here.

16.3.6 External Bus Arbitration

$V_{DD} = 3.3\text{ V} \pm 0.3\text{ V}$

$V_{SS} = 0\text{ V}$

$T_A = -40\text{ to }+85\text{ }^\circ\text{C}$

$C_L = 50\text{ pF}$

Parameter	Symbol	Max. CPU Clock = 50 MHz		Variable CPU Clock 1/2TCL = 1 to 50 MHz		Unit
		min.	max.	min.	max.	
HOLD input setup time to CLKOUT	t ₆₁ SR	15	–	15	–	ns
CLKOUT to HLDA high or BREQ low delay	t ₆₂ CC	–	10	–	10	ns
CLKOUT to HLDA low or BREQ high delay	t ₆₃ CC	–	10	–	10	ns
CSx release	t ₆₄ CC	–	15	–	15	ns
CSx drive	t ₆₅ CC	-3	15	-3	15	ns
Other signals release	t ₆₆ CC	–	15	–	15	ns
Other signals drive	t ₆₇ CC	-3	15	-3	15	ns

Table 20 External bus arbitration

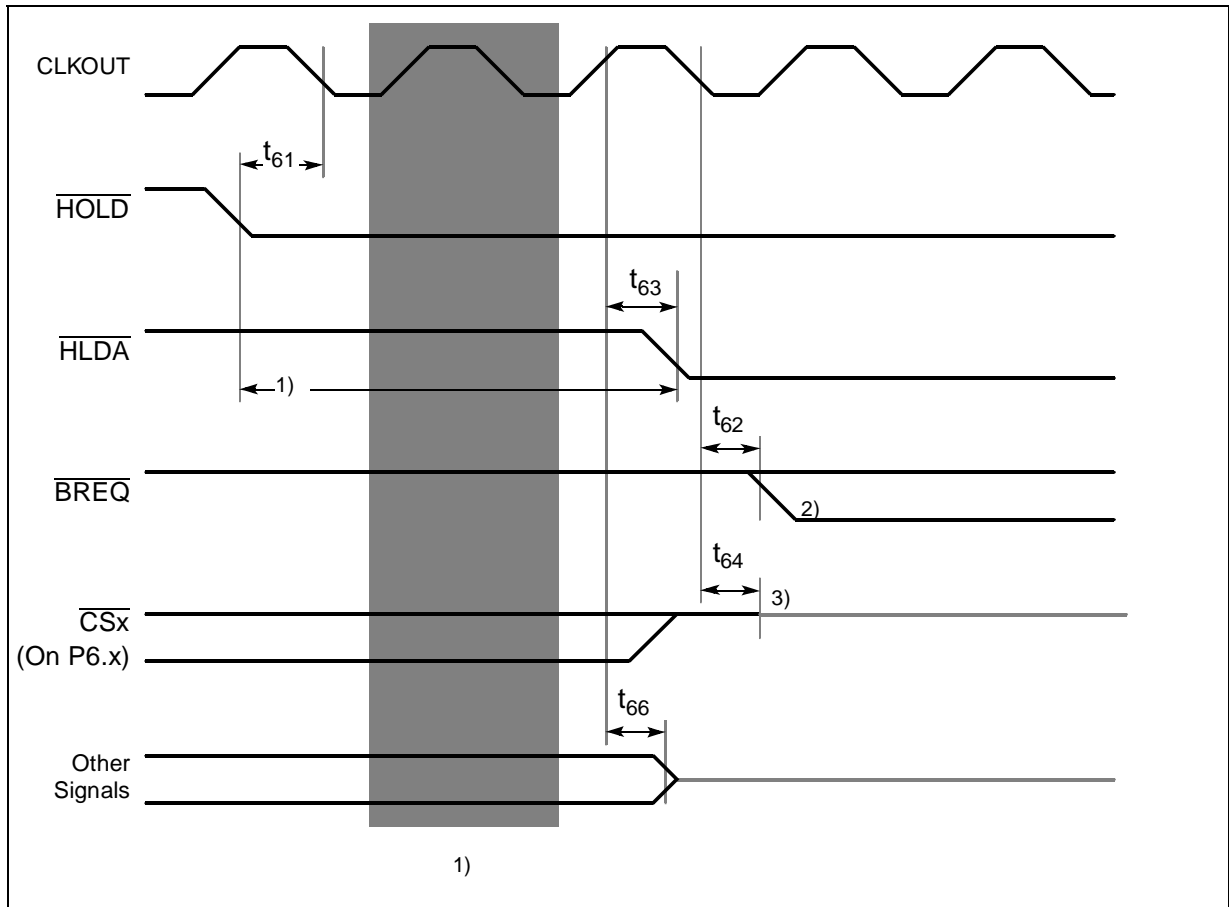

Figure 25 External bus arbitration, releasing the bus

- 1 The ST10R272L will complete the running bus cycle before granting bus access.
- 2 This is the first opportunity for $\overline{\text{BREQ}}$ to become active.
- 3 The $\overline{\text{CS}}$ outputs will be resistive high (pullup) after t_{64} .

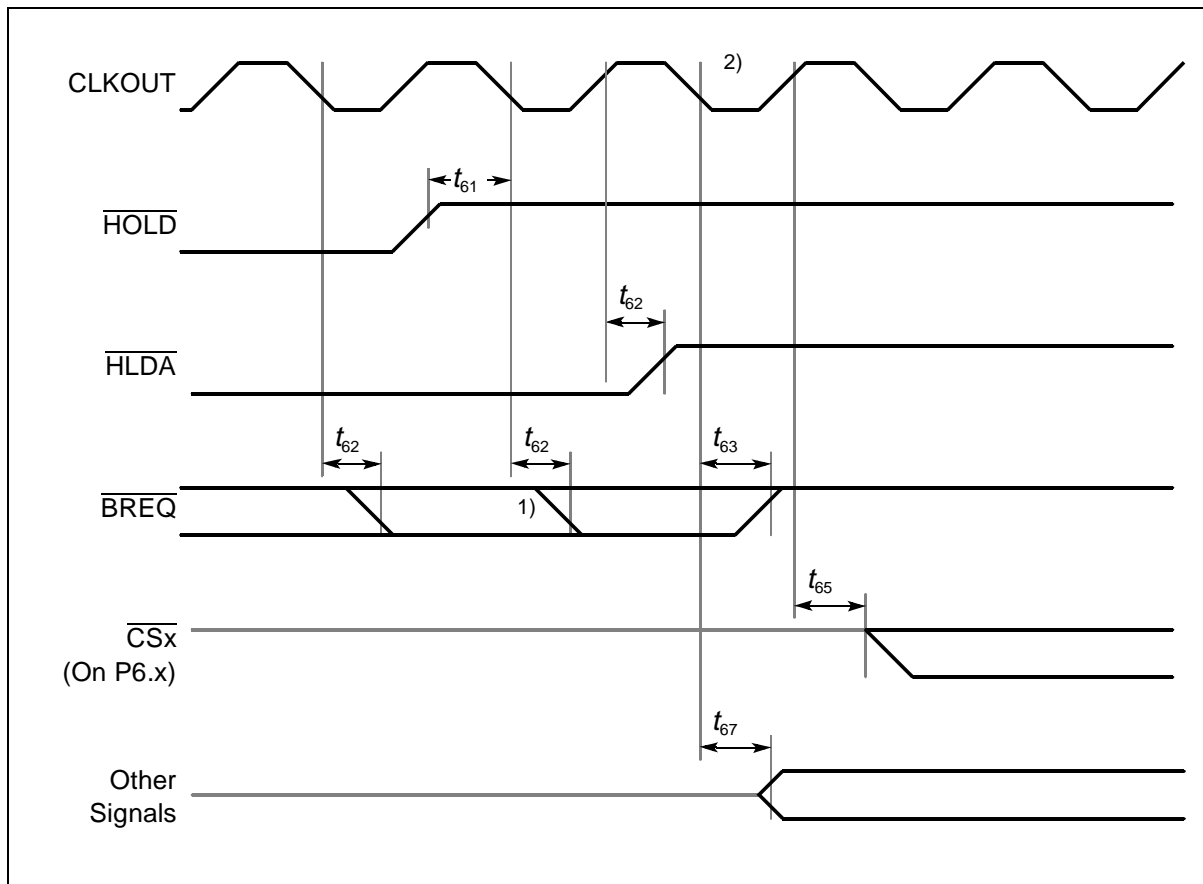

Figure 26 External bus arbitration, (regaining the bus)

- 1 This is the last chance for $\overline{\text{BREQ}}$ to trigger the regain-sequence indicated. Even if $\overline{\text{BREQ}}$ is activated earlier, the regain-sequence is initiated by $\overline{\text{HOLD}}$ going high. Please note that $\overline{\text{HOLD}}$ may also be de-activated without the ST10R272L requesting the bus.
- 2 The next ST10R272L driven bus cycle may start here.

ST10R272L - ELECTRICAL CHARACTERISTICS

16.3.7 External Hardware Reset

$V_{DD} = 3.3 \text{ V} \pm 0.3 \text{ V}$

$V_{SS} = 0 \text{ V}$

$T_A = -40 \text{ to } +85 \text{ }^\circ\text{C}$

$C_L = 50 \text{ pF}$

Parameter	Symbol	Max. CPU Clock = 50 MHz		Variable CPU Clock 1/2TCL = 1 to 50 MHz		Unit
		min.	max.	min.	max.	
Sync. $\overline{\text{RSTIN}}$ low time ¹⁾	t ₇₀ SR	50	–	4 TCL + 10	–	ns
$\overline{\text{RSTIN}}$ low to internal reset sequence start	t ₇₁ CC	4	16	4	16	TCL
internal reset sequence, ($\overline{\text{RSTIN}}$ internally pulled low)	t ₇₂ CC	1024	1024	1024	1024	TCL
$\overline{\text{RSTIN}}$ rising edge to internal reset condition end	t ₇₃ CC	4	6	4	6	TCL
PORT0 system start-up configuration setup to $\overline{\text{RSTIN}}$ rising edge ²⁾	t ₇₄ SR	100	–	100	–	ns
PORT0 system start-up configuration hold after $\overline{\text{RSTIN}}$ rising edge	t ₇₅ SR	1	6	1	6	TCL
Bus signals drive from internal reset end	t ₇₆ CC	0	20	0	20	ns
$\overline{\text{RSTIN}}$ low to signals release	t ₇₇ CC	–	50	–	50	ns
ALE rising edge from internal reset condition end	t ₇₈ CC	8	8	8	8	TCL
Async. $\overline{\text{RSTIN}}$ low time ¹⁾	t ₇₉ SR	1500	–	1500	–	ns

Table 21 External hardware reset

- 1) On power-up reset, the $\overline{\text{RSTIN}}$ pin must be asserted until a stable clock signal is available (about 10...50 ms to allow the on-chip oscillator to stabilize) and until System Start-up Configuration is correct on PORT0 (about 50 μs for internal pullup devices to load 50 pF from $V_{IL\text{min}}$ to $V_{IH\text{min}}$).
- 2) The value of bits 0 (EMU), 1 (ADAPT), 13 to 15 (Clock Configuration) are loaded during hardware reset as long as internal reset signal is active, and have an immediate effect on the system.

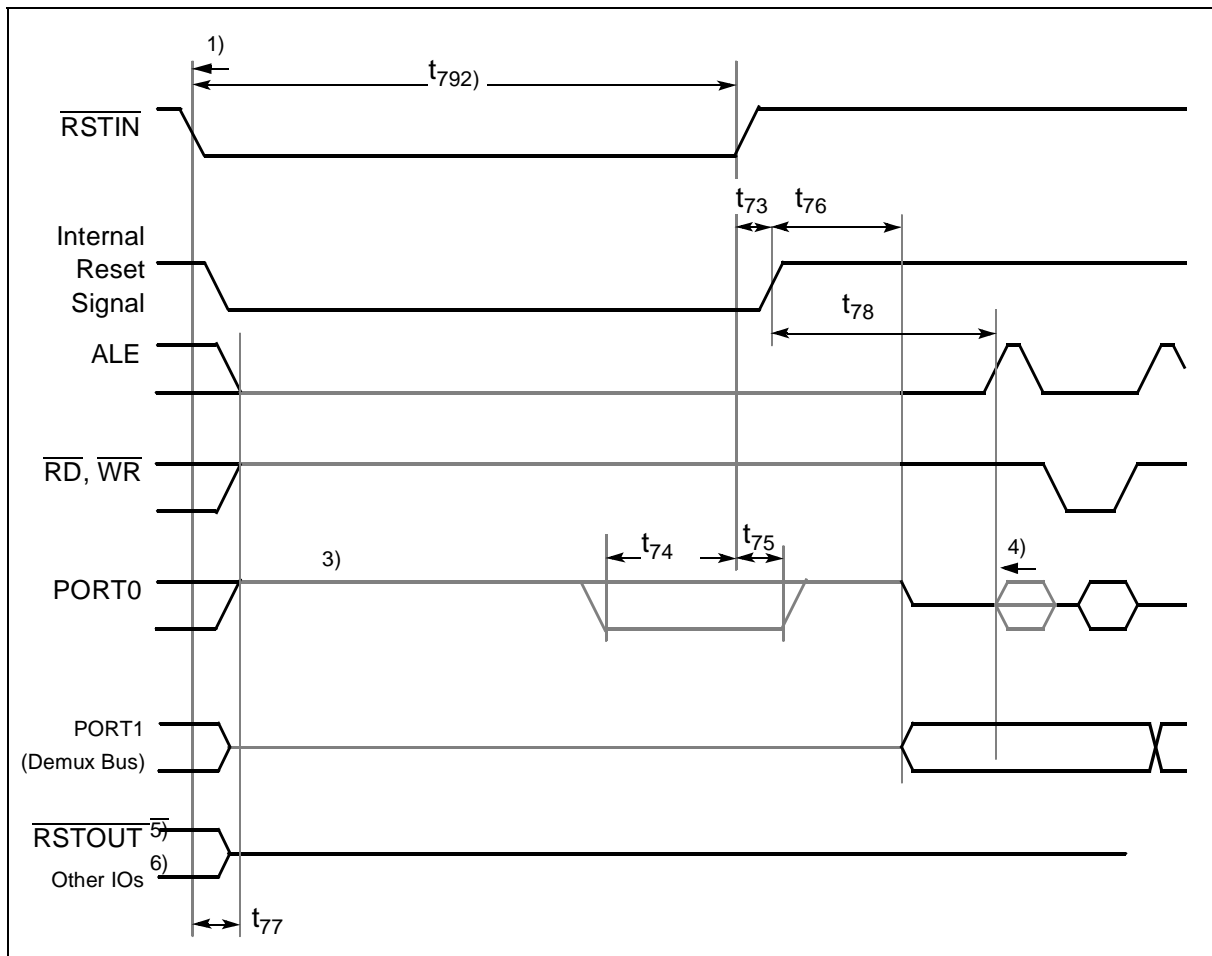

Figure 27 External asynchronous hardware reset (power-up reset): Vpp low

- 1 The ST10R272L is reset in its default state asynchronously with $\overline{\text{RSTIN}}$. The internal RAM content may be altered if an internal write access is in progress.
- 2 On power-up, $\overline{\text{RSTIN}}$ must be asserted t_{79} after a stabilized CPU clock signal is available.
- 3 Internal pullup devices are active on the PORT0 lines, so - input level is high if the respective pin is left open - or is low if the respective pin is connected to an external pulldown device.
- 4 The ST10R272L starts execution here at address 00'0000h.
- 5 $\overline{\text{RSTOUT}}$ stays active until execution of the EINIT (end of initialization) instruction.
- 6 Activation of the IO pins is controlled by software

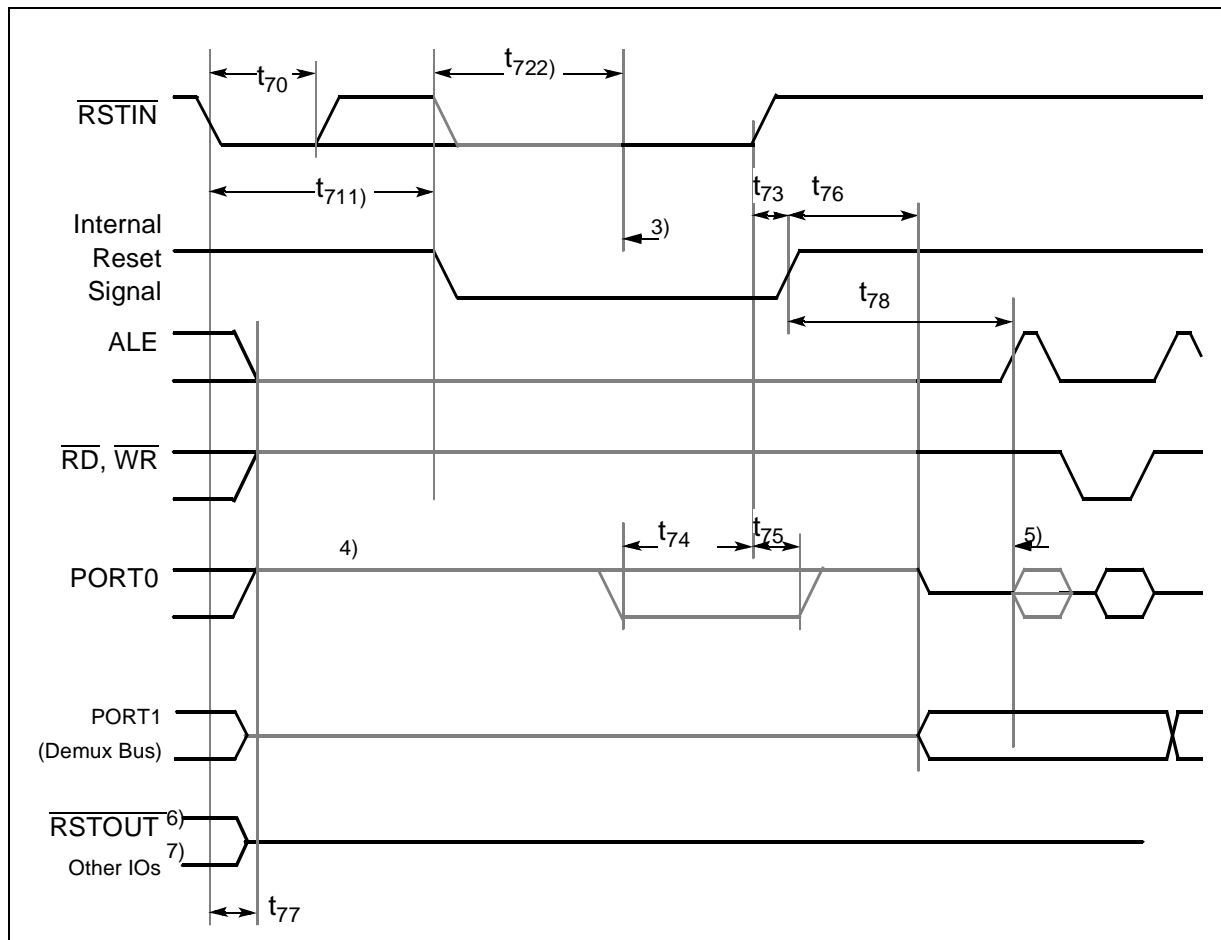

Figure 28 External synchronous hardware reset (warm reset): Vpp high

- 1 The pending internal hold states are cancelled and the current internal access cycle (if any) is completed.
- 2 $\overline{\text{RSTIN}}$ pulled low by internal device during internal reset sequence.
- 3 The reset condition may ends here if $\overline{\text{RSTIN}}$ pin is sampled high after t_{72} .
- 4 Internal pullup devices are active on the PORT0 lines. Their input level is high if the respective pin is left open, or is low if the respective pin is connected to an external pull-down device by resistive high (pullup) after t_{64} .
- 5 The ST10R272L starts execution here at address 00'0000h.
- 6 $\overline{\text{RSTOUT}}$ stays active until execution of the EINIT (End of Initialization) instruction.
- 7 Activation of the IO pins is controlled by software.

16.3.8 Synchronous Serial Port Timing

$V_{CC} = 3.3\text{ V} \pm 0.3\text{ V}$

$V_{SS} = 0\text{ V}$

$T_A = -40\text{ to }+85\text{ }^\circ\text{C}$

$C_L = 50\text{ pF}$

Parameter	Symbol	Max. Baudrate = 25 MBd		Variable Baudrate = 0.2 to 25 MBd		Unit
		min.	max.	min.	max.	
SSP clock cycle time	t ₂₀₀ CC	40	40	4 TCL	512 TCL	ns
SSP clock high time	t ₂₀₁ CC	13	–	t ₂₀₀ /2 - 7	–	ns
SSP clock low time	t ₂₀₂ CC	13	–	t ₂₀₀ /2 - 7	–	ns
SSP clock rise time	t ₂₀₃ CC	–	3	–	3	ns
SSP clock fall time	t ₂₀₄ CC	–	3	–	3	ns
CE active before shift edge	t ₂₀₅ CC	13	–	t ₂₀₀ /2 - 7	–	ns
CE inactive after latch edge	t ₂₀₆ CC	33	47	t ₂₀₀ - 7	t ₂₀₀ + 7	ns
Write data valid after shift edge	t ₂₀₇ CC	–	7	–	7	ns
Write data hold after shift edge	t ₂₀₈ CC	0	–	0	–	ns
Write data hold after latch edge	t ₂₀₉ CC	15	25	t ₂₀₀ /2 - 5	t ₂₀₀ /2 + 5	ns
Read data active after latch edge	t ₂₁₀ SR	27	–	t ₂₀₀ /2 + 7	–	ns
Read data setup time before latch edge	t ₂₁₁ SR	15	–	15	–	ns
Read data hold time after latch edge	t ₂₁₂ SR	0	–	0	–	ns

Table 22 Synchronous serial port timing

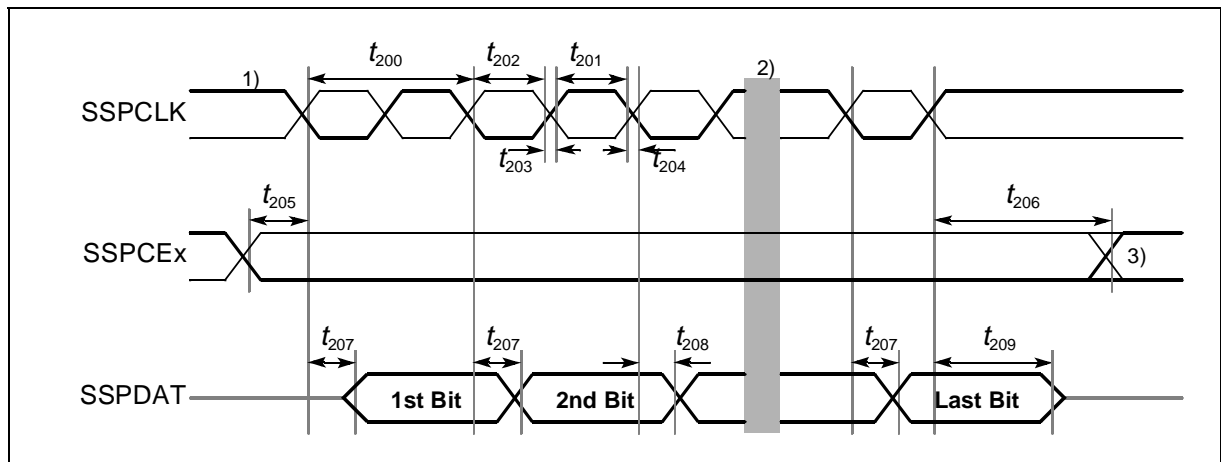

Figure 29 SSP write timing

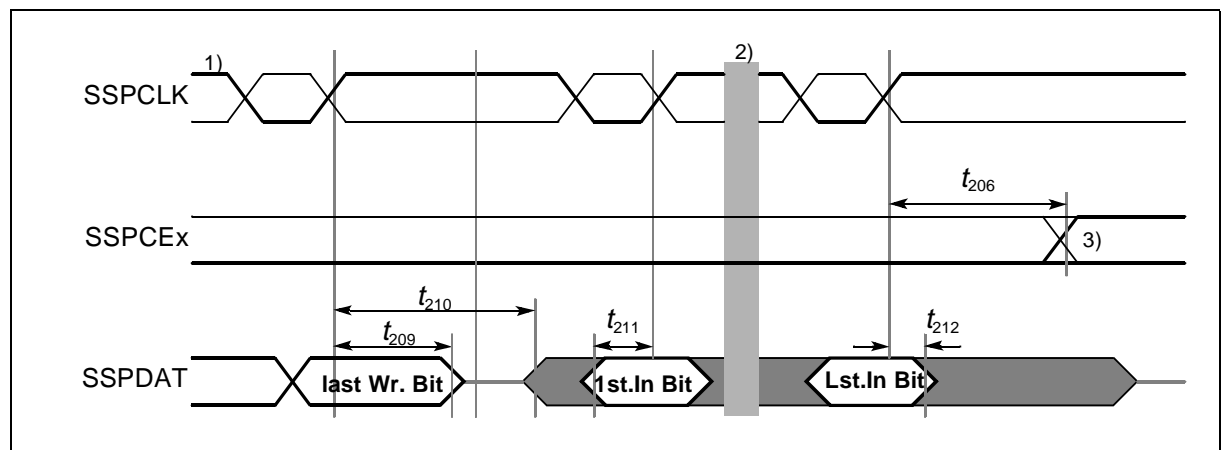

Figure 30 SSP read timing

- 1 The transition of shift and latch edge of SSPCLK is programmable. This figure uses the falling edge as shift edge (drawn bold).
- 2 The bit timing is repeated for all bits to be transmitted or received.
- 3 The active level of the chip enable lines is programmable. This figure uses an active low CE (drawn bold). At the end of a transmission or reception the CE signal is disabled in single transfer mode. In continuous transfer mode it remains active.

17 PACKAGE MECHANICAL DATA

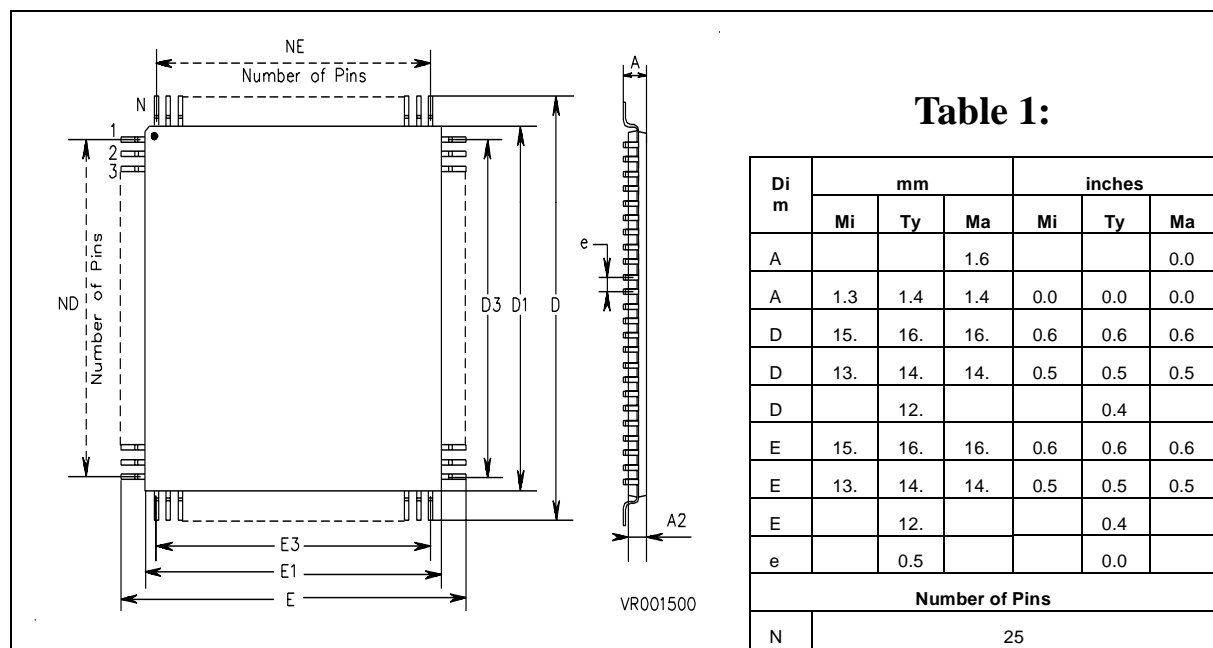

Figure 31 Package outline TQFP100 (14 x 14 mm)

18 ORDERING INFORMATION

Sales type	Temperature range	Package
ST10R272LT1	0°C to 70°C	TQFP100 (14x 14)
ST10R272LT6	-40°C to +85°C	

Information furnished is believed to be accurate and reliable. However, STMicroelectronics assumes no responsibility for the consequences of use of such information nor for any infringement of patents or other rights of third parties which may result from its use. No license is granted by implication or otherwise under any patent or patent rights of STMicroelectronics. Specifications mentioned in this publication are subject to change without notice. This publication supersedes and replaces all information previously supplied. STMicroelectronics products are not authorized for use as critical components in life support devices or systems without the express written approval of STMicroelectronics.

The ST logo is a registered trademark of STMicroelectronics

©2001 STMicroelectronics - All Rights Reserved.

Purchase of I²C Components by STMicroelectronics conveys a license under the Philips I²C Patent. Rights to use these components in an I²C system is granted provided that the system conforms to the I²C Standard Specification as defined by Philips.



STMicroelectronics Group of Companies

Australia - Brazil - China - Finland - France - Germany - Hong Kong - India - Italy - Japan - Malaysia - Malta - Morocco - Singapore - Spain
Sweden - Switzerland - United Kingdom - U.S.A.

<http://www.st.com>

Looking for pricing, stock, or lifecycle information?

Click below to explore more details on WIN SOURCE:

-  [View ST10R272LT6](#) on WIN SOURCE
-  [STMicroelectronics](#) Information

Optimize Your Supply Chain with WIN SOURCE Solutions

-  Global Sourcing Solution
-  Obsolete Management
-  Cost Control Management
-  Shortage Management
-  Alternative Solution
-  Excess Inventory Management