

The SST12LP15A is a high-power and high-gain power amplifier based on the highly-reliable InGaP/GaAs HBT technology. Easily configured for high-power applications with superb power-added efficiency while operating over the 2.4-2.5 GHz frequency band, it typically provides 32 dB gain with 26% power-added efficiency @  $P_{OUT} = 24$  dBm for 802.11g and 27% power-added efficiency @  $P_{OUT} = 25$  dBm for 802.11b. The SST12LP15A has excellent linearity while meeting 802.11g spectrum mask at 25 dBm. The power amplifier IC features easy board-level usage along with high-speed power-up/down control and is offered in 16-contact VQFN package

## Features

- **High Gain:**
  - Typically 32 dB gain across 2.4–2.5 GHz over temperature 0°C to +85°C
- **High linear output power:**
  - >29 dBm P1dB
  - Please refer to “Absolute Maximum Stress Ratings” on page 5
  - Meets 802.11g OFDM ACPR requirement up to 25 dBm
  - Added EVM~4% up to 23 dBm for 54 Mbps 802.11g signal
  - Meets 802.11b ACPR requirement up to 25 dBm
- **High power-added efficiency/Low operating current for both 802.11g/b applications**
  - ~26%/300 mA @  $P_{OUT} = 24$  dBm for 802.11g
  - ~27%/350 mA @  $P_{OUT} = 25$  dBm for 802.11b
- **Built-in Ultra-low  $I_{REF}$  power-up/down control**
  - $I_{REF} \sim 2$  mA
- **Low idle current**
  - ~80 mA  $I_{CQ}$
- **High-speed power-up/down**
  - Turn on/off time (10%-90%) <100 ns
  - Typical power-up/down delay with driver delay included <200 ns
- **High temperature stability**
  - ~1 dB gain/power variation between 0°C to +85°C
  - ~1 dB detector variation over 0°C to +85°C
- **Low shut-down current (~1  $\mu$ A)**
- **On-chip power detection**
- **25 dB dynamic range on-chip power detection**
- **Simple input/output matching**
- **Packages available**
  - 16-contact VQFN (3mm x 3mm)
- **All non-Pb (lead-free) devices are RoHS compliant**

## Applications

- **WLAN (IEEE 802.11b/g/n)**
- **Home RF**
- **Cordless phones**
- **2.4 GHz ISM wireless equipment**

### Product Description

The SST12LP15A is a high-power and high-gain power amplifier based on the highly-reliable InGaP/GaAs HBT technology.

The SST12LP15A can be easily configured for high-power applications with superb power-added efficiency while operating over the 2.4-2.5 GHz frequency band. It typically provides 32 dB gain with 26% power-added efficiency @  $P_{OUT} = 24$  dBm for 802.11g and 27% power-added efficiency @  $P_{OUT} = 25$  dBm for 802.11b.

The SST12LP15A has excellent linearity, typically ~4% added EVM at 23 dBm output power which is essential for 54 Mbps 802.11g operation while meeting 802.11g spectrum mask at 25 dBm. SST12LP15A also has wide-range (>25 dB), temperature-stable (~1 dB over 85°C), single-ended/differential power detectors which lower users' cost on power control.

The power amplifier IC also features easy board-level usage along with high-speed power-up/down control. Ultra-low reference current (total  $I_{REF} \sim 2$  mA) makes the SST12LP15A controllable by an on/off switching signal directly from the baseband chip. These features coupled with low operating current make the SST12LP15A ideal for the final stage power amplification in battery-powered 802.11b/g/n WLAN transmitter applications.

The SST12LP15A is offered in 16-contact VQFN package. See Figure 2 for pin assignments and Table 1 for pin descriptions.

### Functional Blocks

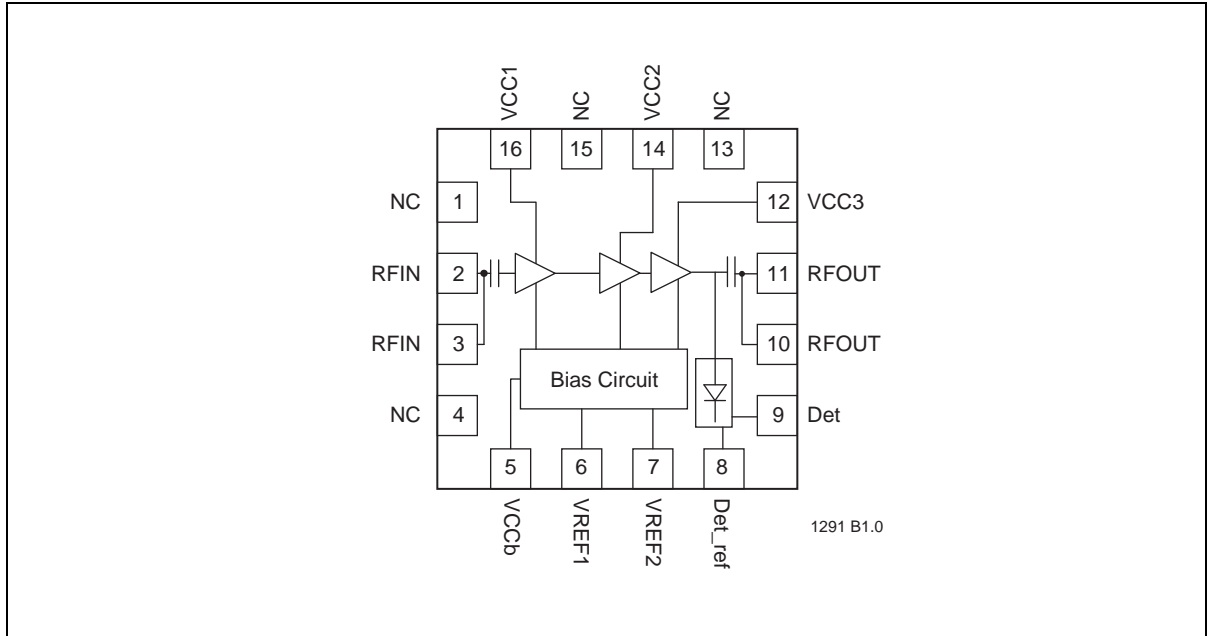
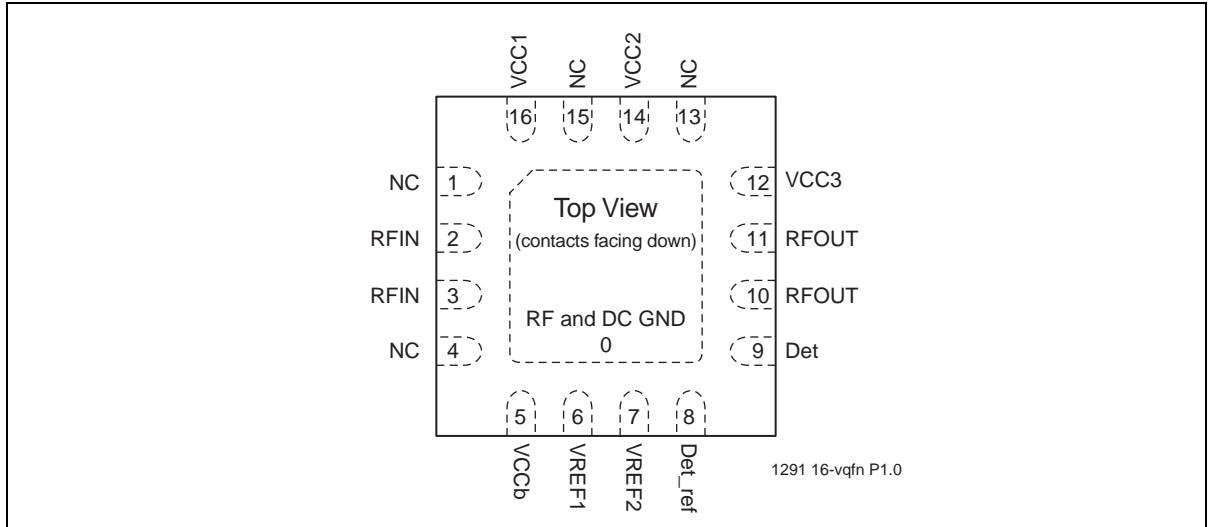


Figure 1: Functional Block Diagram6

### Pin Assignments



**Figure 2:** Pin Assignments for 16-contact VQFN

### Pin Descriptions

**Table 1:** Pin Description

Symbol	Pin No.	Pin Name	Type <sup>1</sup>	Function
GND	0	Ground		The center pad should be connected to RF ground with several low inductance, low resistance vias.
NC	1	No Connection		Unconnected pins.
RFIN	2		I	RF input, DC decoupled
RFIN	3		I	RF input, DC decoupled
NC	4	No Connection		Unconnected pins.
VCCb	5	Power Supply	PWR	Supply voltage for bias circuit
VREF1	6		PWR	1st and 2nd stage idle current control
VREF2	7		PWR	3rd stage idle current control
Det_ref	8		O	On-chip power detector reference
Det	9		O	On-chip power detector
RFOUT	10		O	RF output
RFOUT	11		O	RF output
VCC3	12	Power Supply	PWR	Power supply, 3rd stage
NC	13	No Connection		Unconnected pins.
VCC2	14	Power Supply	PWR	Power supply, 2nd stage
NC	15	No Connection		Unconnected pins.
VCC1	16	Power Supply	PWR	Power supply, 1st stage

1. I=Input, O=Output

### Electrical Specifications

The AC and DC specifications for the power amplifier interface signals. Refer to Table 3 for the DC voltage and current specifications. Refer to Figures 3 through 10 for the RF performance.

**Absolute Maximum Stress Ratings** (Applied conditions greater than those listed under “Absolute Maximum Stress Ratings” may cause permanent damage to the device. This is a stress rating only and functional operation of the device at these conditions or conditions greater than those defined in the operational sections of this data sheet is not implied. Exposure to absolute maximum stress rating conditions may affect device reliability.)

Input power to pins 2 and 3 ( $P_{IN}$ )	+5 dBm
Average output power ( $P_{OUT}$ ) <sup>1</sup>	+28 dBm
Supply Voltage at pins 5, 12, 14, 16 ( $V_{CC}$ )	-0.3V to +4.6V
Reference voltage to pins 6 ( $V_{REF1}$ ) and pin 7 ( $V_{REF2}$ )	-0.3V to +3.6V
DC supply current ( $I_{CC}$ )	500 mA
Operating Temperature ( $T_A$ )	-40°C to +85°C
Storage Temperature ( $T_{STG}$ )	-40°C to +120°C
Maximum Junction Temperature ( $T_J$ )	+150°C
Surface Mount Solder Reflow Temperature	260°C for 10 seconds

1. Never measure with CW source. Pulsed single-tone source with <50% duty cycle is recommended. Exceeding the maximum rating of average output power could cause permanent damage to the device.

**Table 2: Operating Range**

Range	Ambient Temp	$V_{DD}$
Industrial	-40°C to +85°C	3.3V

T2.1 75056

**Table 3: DC Electrical Characteristics at 25°C**

Symbol	Parameter	Min.	Typ	Max.	Unit
$V_{CC}$	Supply Voltage at pins 5, 12, 14, 16	3.0	3.3	4.2	V
$I_{CC}$	Supply Current				
	for 802.11g, 24 dBm		300		mA
	for 802.11b, 25 dBm		350		mA
$I_{CQ}$	Idle current for 802.11g to meet EVM<4% @ 23dBm		80		mA
$I_{OFF}$	Shut down current		1		μA
$V_{REG1}$	Reference Voltage for 1st and 2nd Stage, with 270Ω resistor	2.85	2.90	2.95	V
$V_{REG2}$	Reference Voltage for 3rd Stage, with 100Ω resistor	2.85	2.90	2.95	V

T3.1 75056

**Table 4:** AC Electrical Characteristics for Configuration at 25°C

Symbol	Parameter	Min.	Typ	Max.	Unit
F <sub>L-U</sub>	Frequency range in 802.11b/g applications (see Figure 11)	2400		2485	MHz
P <sub>OUT</sub>	Output power @ PIN = -10 dBm 11b signals		23		dBm
	@ PIN = -10 dBm 11g signals		23		dBm
G	Small signal gain	31	32		dB
G <sub>VAR1</sub>	Gain variation over each band (2400-2485 MHz)			±0.5	dB
G <sub>VAR2</sub>	Gain ripple over channel (Gain variation over 20 MHz)		0.2		dB
ACPR	Meet 11b spectrum mask	24	25		dBm
	Meet 11g OFDM 54 MBPS spectrum mask	24	25		dBm
Added EVM	@ 23 dBm output with 11g OFDM 54 MBPS signal		3.5		%
	2f, 3f, 4f, 5f Harmonics at 22 dBm, without trapping capacitors			-40	dBc

T4.2 75056

### Typical Performance Characteristics

Test Conditions:  $V_{CC} = 3.3V$ ,  $T_A = 25^\circ C$  Unless otherwise specified.

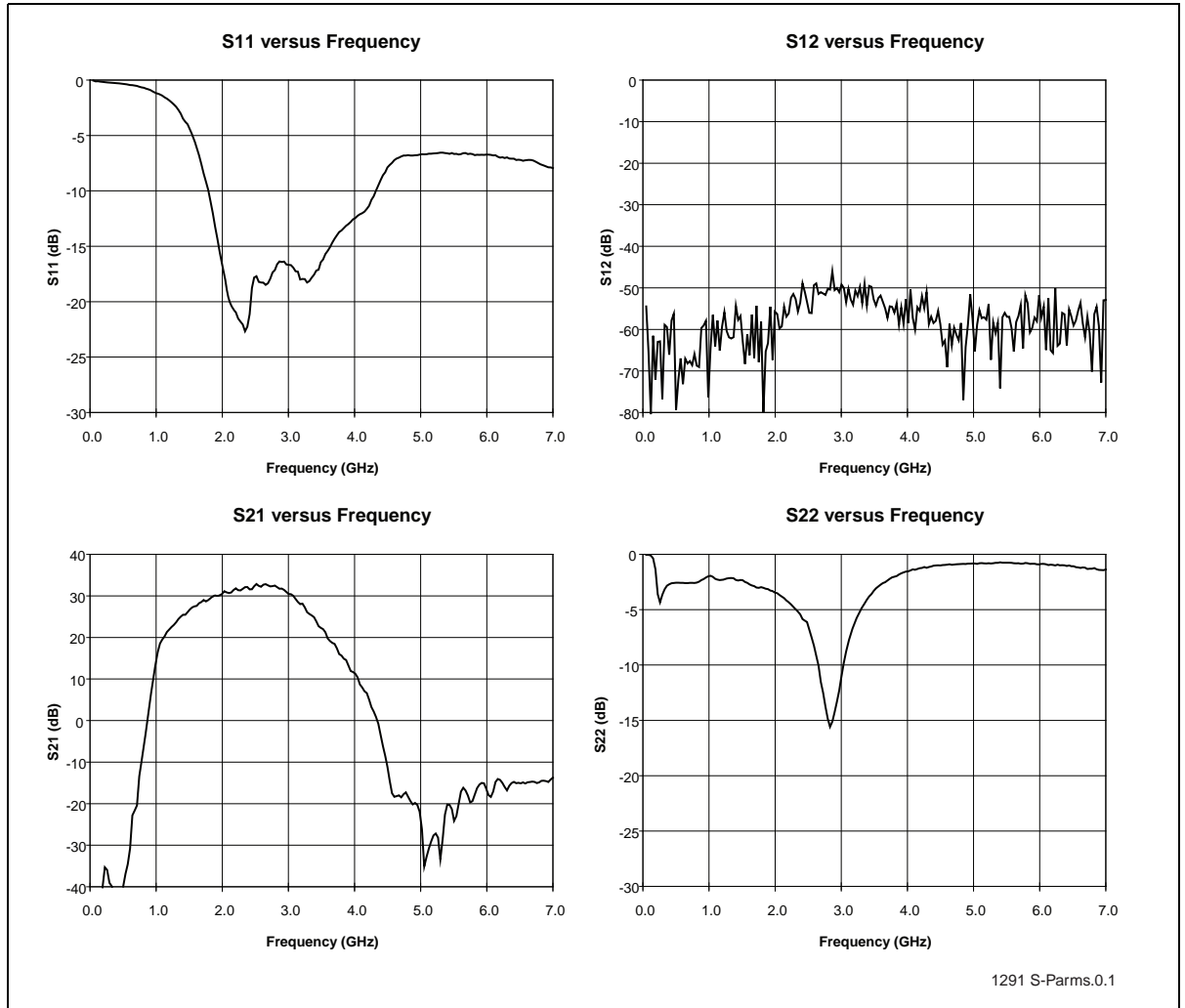


Figure 3: S-Parameters

### Typical Performance Characteristics

Test Conditions:  $V_{CC} = 3.3V$ ,  $T_A = 25^\circ C$ , 54 Mbps 802.11g OFDM Signal

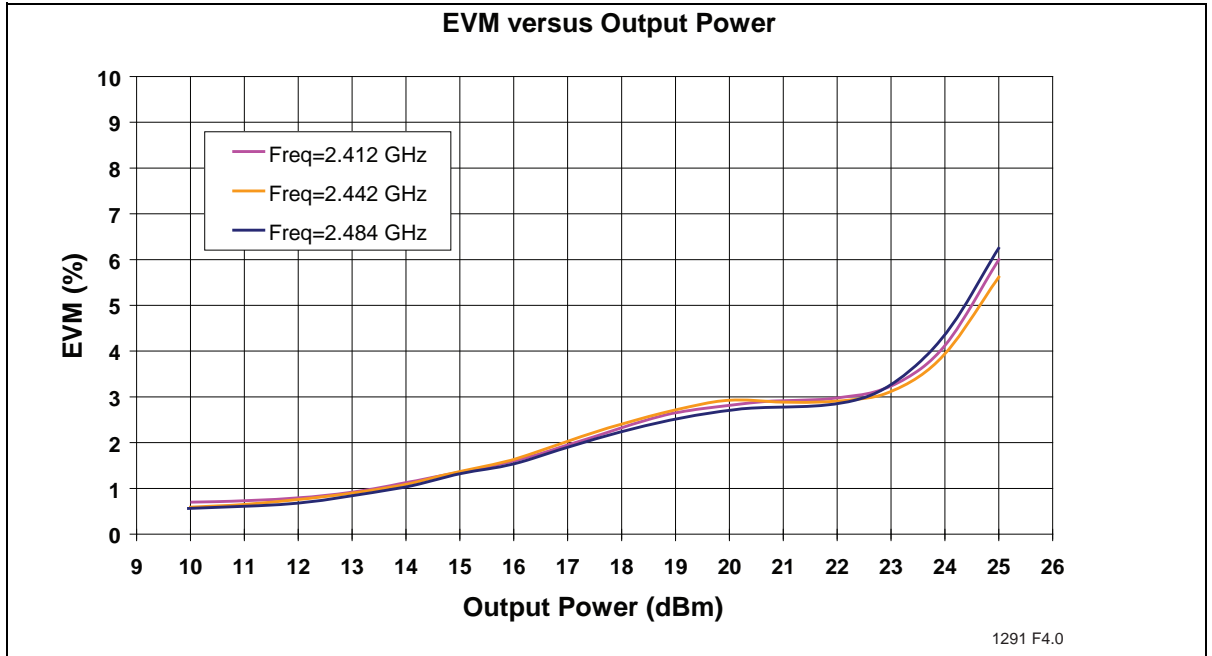


Figure 4: EVM versus Output Power measured with “Data plus Sequence” channel estimation

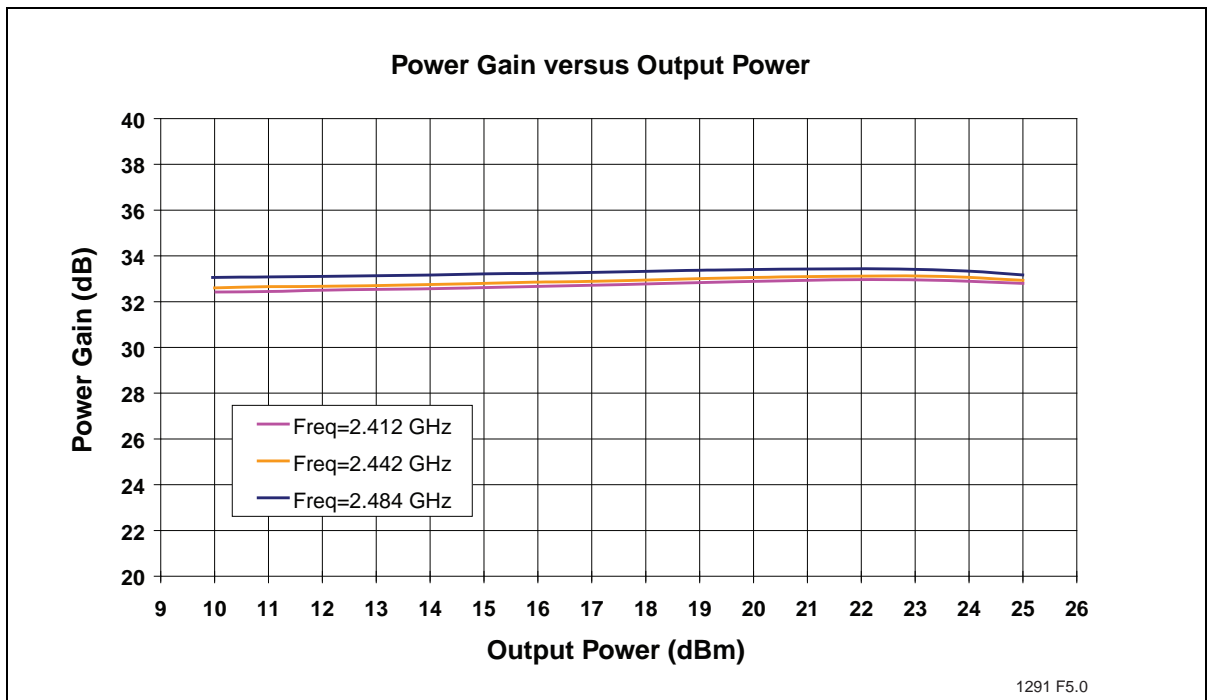


Figure 5: Power Gain versus Output Power

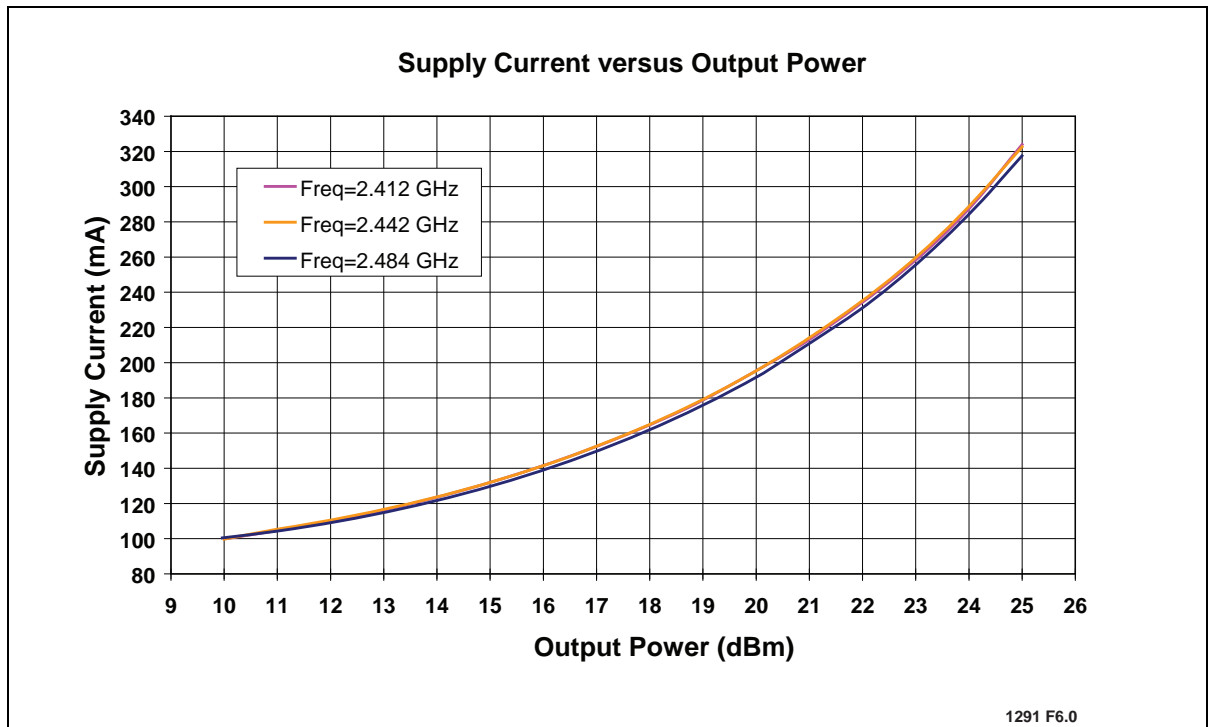


Figure 6: Total Current Consumption for 802.11g Operation versus Output Power

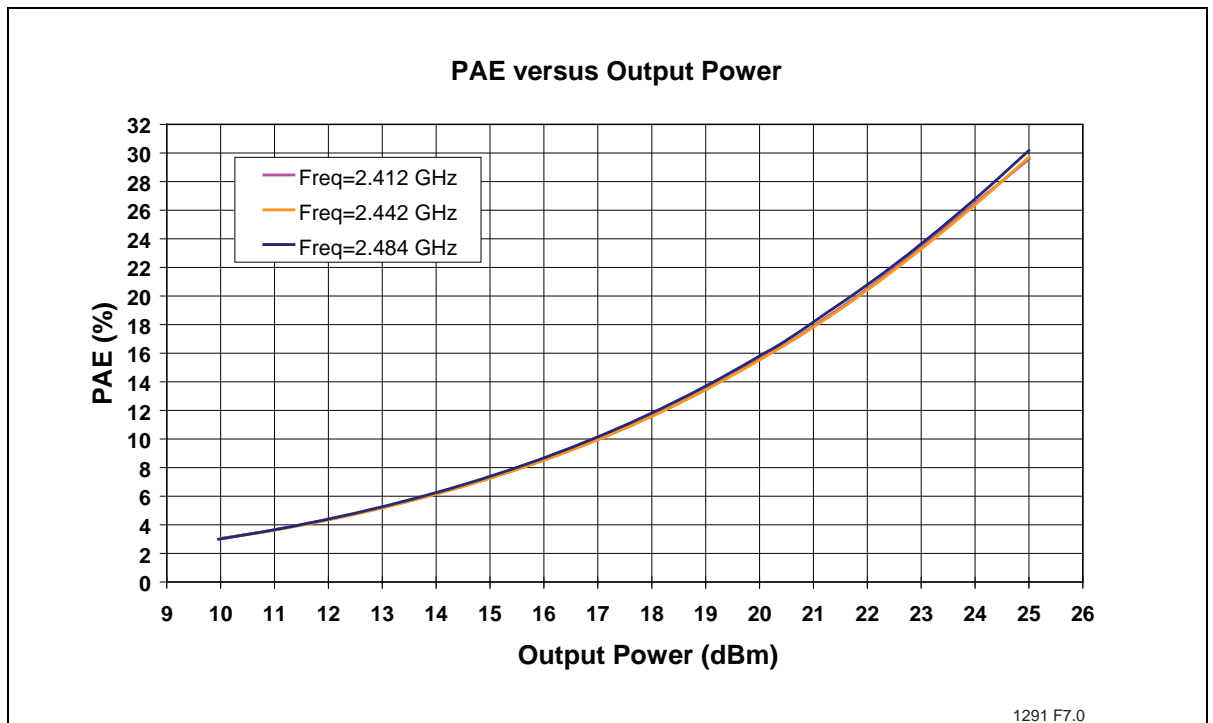


Figure 7: PAE versus Output Power

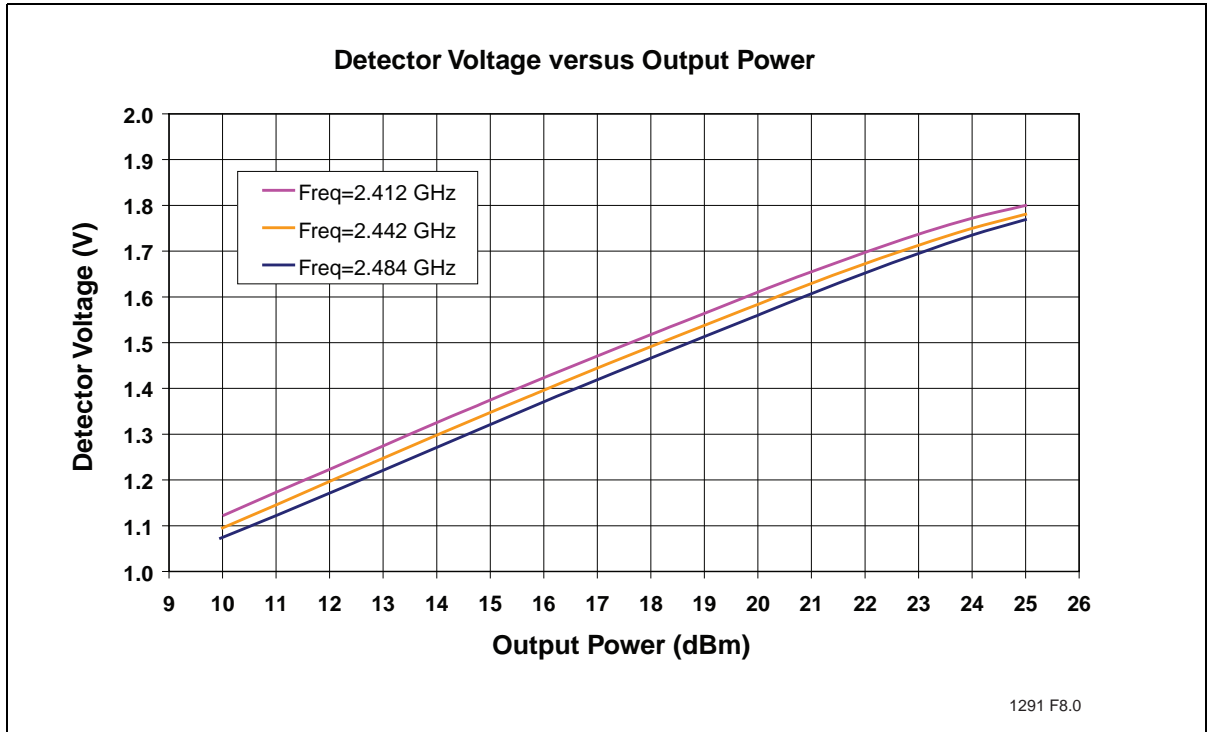


Figure 8: Detector Characteristic versus Output Power

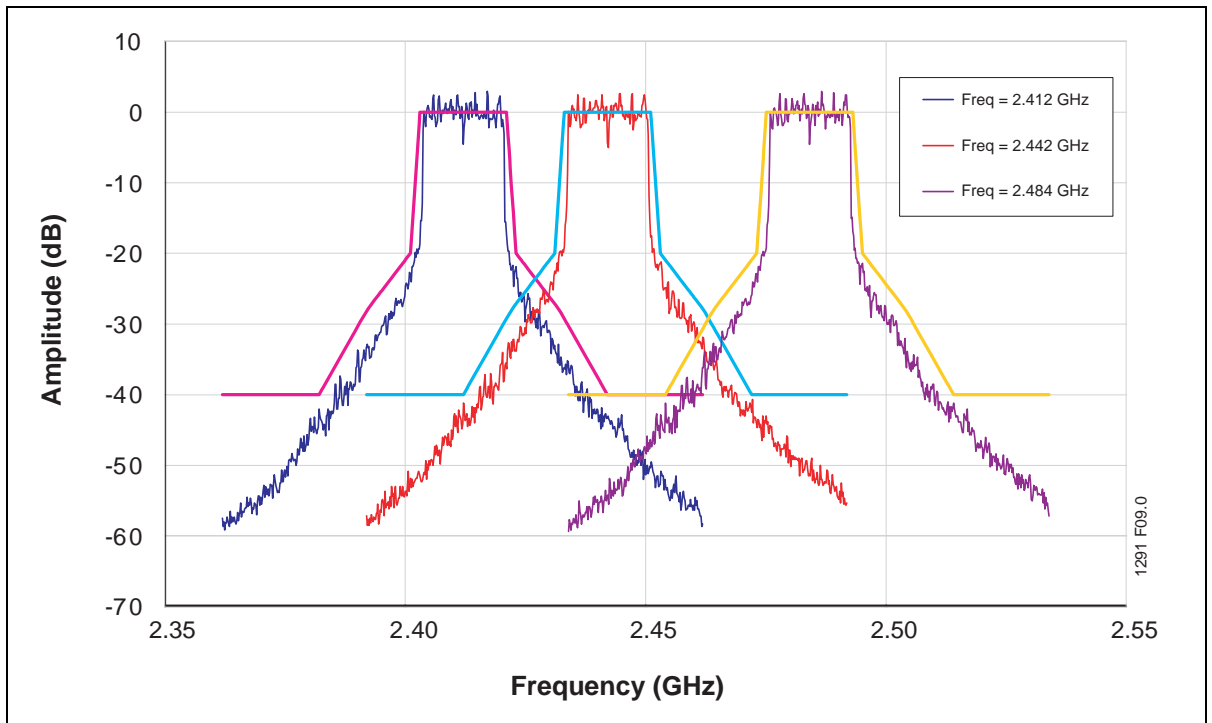
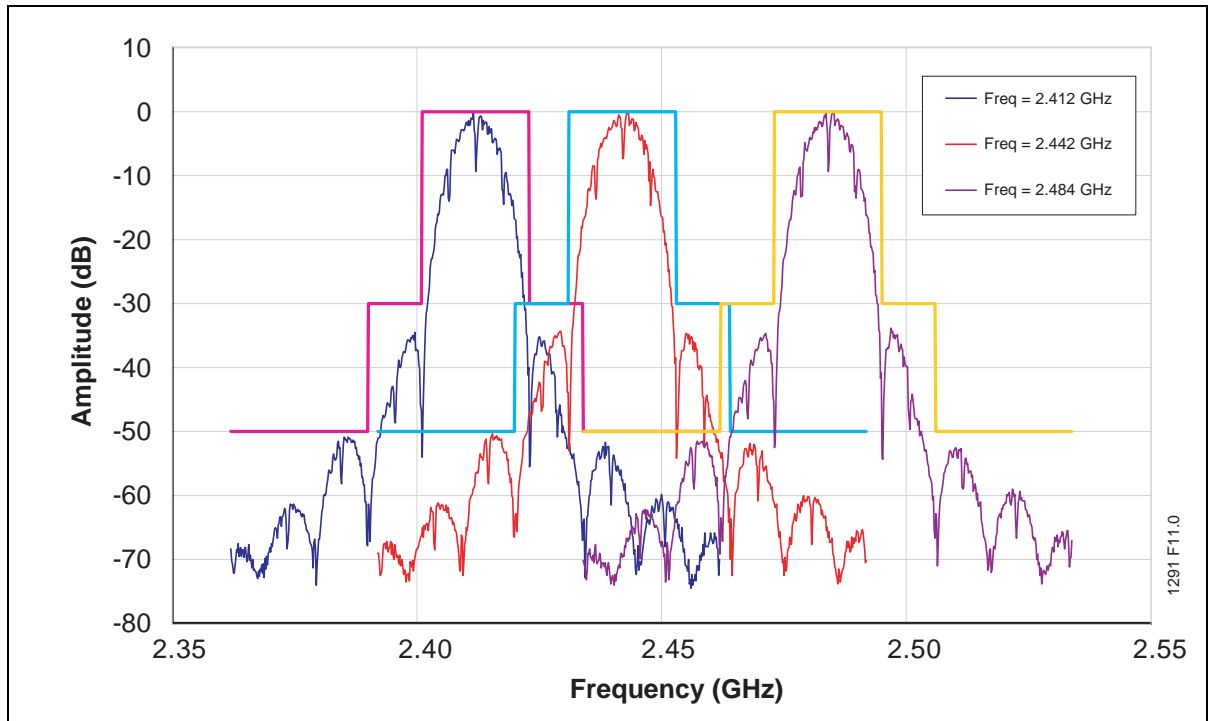


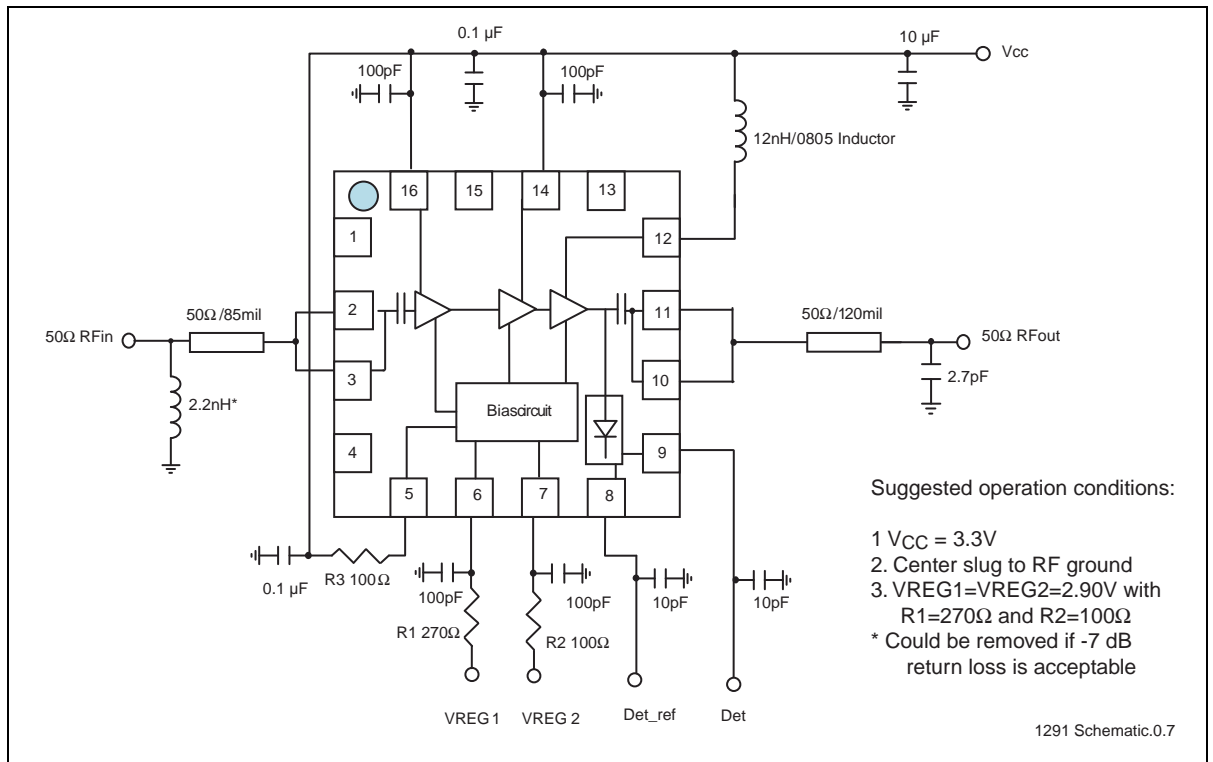
Figure 9: 802.11g Spectrum Mask at 24 dBm, Total current 300 mA

### Typical Performance Characteristics

Test Conditions:  $V_{CC} = 3.3V$ ,  $T_A = 25^\circ C$ , 1 Mbps 802.11b CCK signal

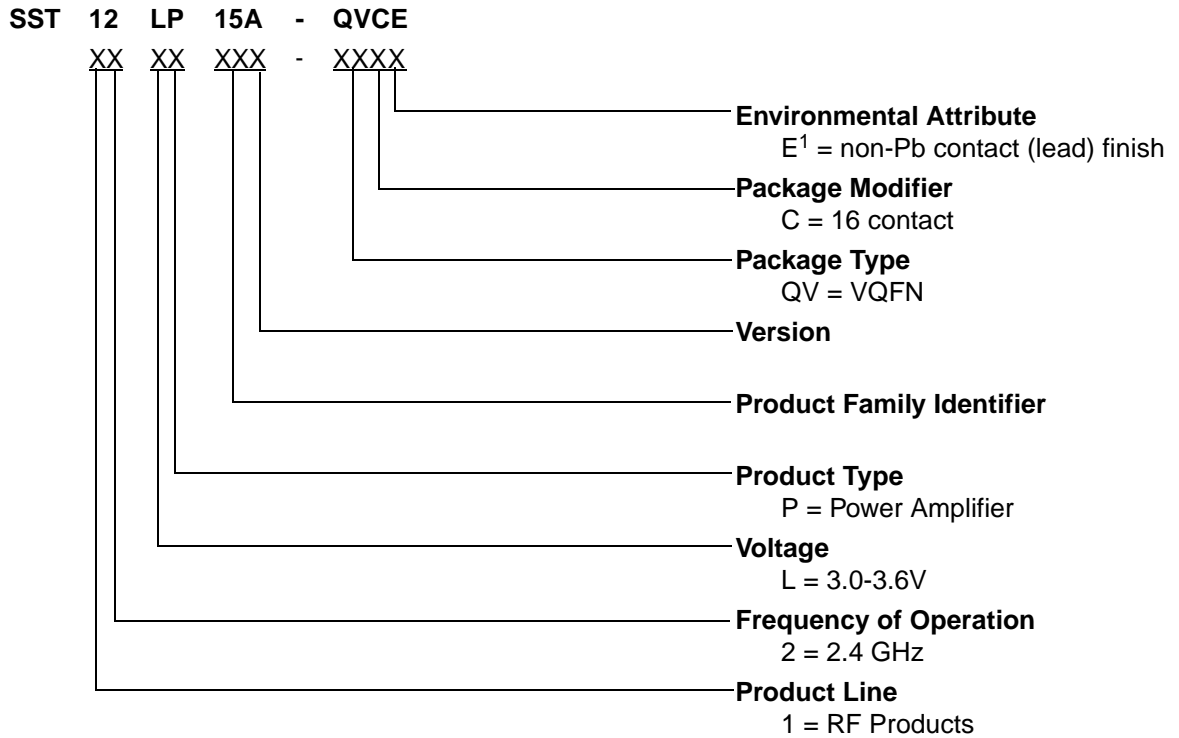


**Figure 10:** 802.11b Spectrum Mask at 25 dBm, Total current 350 mA



**Figure 11:** Typical Schematic for High-Power, High-Efficiency 802.11b/g Applications

### Product Ordering Information



1. Environmental suffix "E" denotes non-Pb solder. SST non-Pb solder devices are "RoHS Compliant".

#### Valid combinations for SST12LP15A

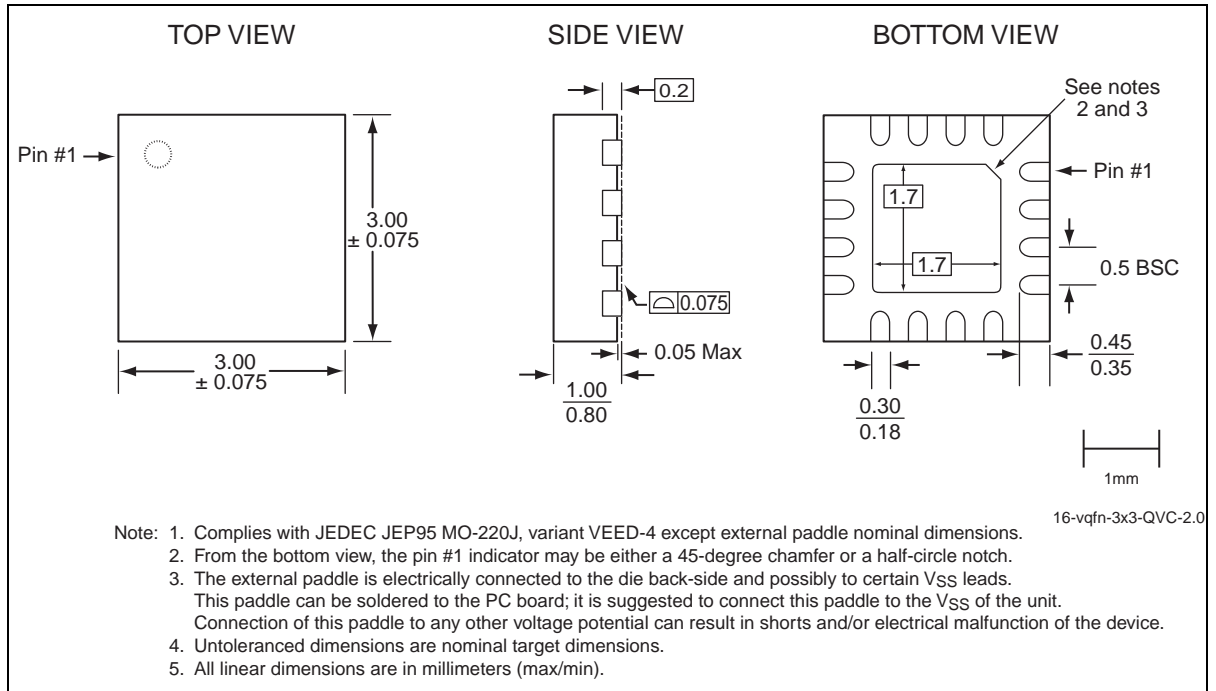
SST12LP15A-QVCE

#### SST12LP15A Evaluation Kits

SST12LP15A-QVCE-K

**Note:** Valid combinations are those products in mass production or will be in mass production. Consult your SST sales representative to confirm availability of valid combinations and to determine availability of new combinations.

### Packaging Diagrams



**Figure 12:** 16-contact Very-thin Quad Flat No-lead (VQFN)  
SST Package Code: QVC

**Table 5: Revision History**

Revision	Description	Date
00	<ul style="list-style-type: none"> <li>Initial release of data sheet</li> </ul>	Mar 2005
01	<ul style="list-style-type: none"> <li>Updated values for gain and efficiency on page 1</li> <li>Updated values for VREG1 and VREG2 in Table 3 on page 5</li> <li>Removed stability parameter from Table 4 on page 6</li> <li>Updated the typical application schematic on page 12</li> <li>Updated QVC package drawing.</li> <li>Updated "Absolute Maximum Stress Ratings" on page 5</li> </ul>	Mar 2006
02	<ul style="list-style-type: none"> <li>Added information for 2.3-2.4 and 2.5-2.6 applications</li> <li>Removed leaded part numbers</li> </ul>	Jul 2006
03	<ul style="list-style-type: none"> <li>Updated "Features" and "Product Description" on page 2</li> <li>Revised Table 3 on page 5 and Table 4 on page 6</li> <li>Updated values in Figure 11 on page 12.</li> <li>Removed two schematics</li> <li>Updated Figures 3 - 8</li> </ul>	Sep 2008
04	<ul style="list-style-type: none"> <li>Updated "Contact Information".</li> </ul>	Feb 2009
A	<ul style="list-style-type: none"> <li>Applied new document format</li> <li>Released document under letter revision system</li> <li>Updated Spec number from S71291 to DS75056</li> </ul>	Apr 2013

ISBN:978-1-62077-166-2

© 2013 Silicon Storage Technology, Inc—a Microchip Technology Company. All rights reserved.

SST, Silicon Storage Technology, the SST logo, SuperFlash, MTP, and FlashFlex are registered trademarks of Silicon Storage Technology, Inc. MPF, SQI, Serial Quad I/O, and Z-Scale are trademarks of Silicon Storage Technology, Inc. All other trademarks and registered trademarks mentioned herein are the property of their respective owners.

Specifications are subject to change without notice. Refer to [www.microchip.com](http://www.microchip.com) for the most recent documentation. For the most current package drawings, please see the Packaging Specification located at <http://www.microchip.com/packaging>.

Memory sizes denote raw storage capacity; actual usable capacity may be less.

SST makes no warranty for the use of its products other than those expressly contained in the Standard Terms and Conditions of Sale.

For sales office locations and information, please see [www.microchip.com](http://www.microchip.com).

---

Silicon Storage Technology, Inc.  
 A Microchip Technology Company  
[www.microchip.com](http://www.microchip.com)

---

## Looking for pricing, stock, or lifecycle information?

Click below to explore more details on WIN SOURCE:

- ⊖ [View SST12LP15A-QVCE on WIN SOURCE](#)
- ⊖ [Microchip Technology](#) Information

## Optimize Your Supply Chain with WIN SOURCE Solutions

- ✓ Global Sourcing Solution
- ✓ Obsolete Management
- ✓ Cost Control Management
- ✓ Shortage Management
- ✓ Alternative Solution
- ✓ Excess Inventory Management